



Install your ASA r2 system

ASA r2

NetApp
September 26, 2024

Table of Contents

- Install your ASA r2 system 1
 - Installation and setup workflow for ASA r2 storage systems 1
 - Installation requirements for ASA r2 storage systems 1
 - Prepare to install an ASA r2 storage system 3
 - Install your ASA r2 storage system 4
 - Cable the hardware for your ASA r2 storage system 5
 - Power on your ASA r2 storage system. 18

Install your ASA r2 system

Installation and setup workflow for ASA r2 storage systems

To install and configure your ASA r2 system, you review the hardware requirements, prepare your site, install and cable the hardware components, power on the system, and set up your ONTAP cluster.

1

Review the hardware installation requirements

Review the hardware requirements to install your ASA r2 storage system.

2

Prepare to install the ASA r2 storage system

To prepare to install your ASA r2 system, you need to get the site ready, check the environmental and electrical requirements, and ensure there's enough rack space. Then, unpack the equipment, compare its contents to the packing slip, and register the hardware to access support benefits.

3

Install the hardware for the ASA r2 storage system

To install the hardware, install the rail kits for your storage system and shelves, and then install and secure your storage system in the cabinet or telco rack. Next, slide the shelves onto the rails. Finally, attach cable management devices to the rear of the storage system for organized cable routing.

4

Cable the controllers and storage shelves for the ASA r2 storage system

To cable the hardware, first connect the storage controllers to your network and then connect the controllers to your storage shelves.

5

Power on the ASA r2 storage system

Before you power on the controllers, power on each NS224 shelf and assign a unique shelf ID to ensure each shelf is uniquely identified within the setup.

Installation requirements for ASA r2 storage systems

Review the equipment needed and the lifting precautions for your ASA r2 storage system and storage shelves.

Equipment needed for install

To install your ASA r2 storage system, you need the following equipment and tools.

- Access to a Web browser to configure your storage system
- Electrostatic discharge (ESD) strap

- Flashlight
- Laptop or console with a USB/serial connection
- Paperclip or narrow tipped ball point pen for setting NS224 storage shelf IDs
- Phillips #2 screwdriver

Lifting precautions

ASA r2 storage systems and NS224 storage shelves are heavy. Exercise caution when lifting and moving these items.

Storage system weights

Take the necessary precautions when moving or lifting your ASA r2 storage system.

ASA A1K

An ASA A1K storage system can weigh up to 62.83 lbs (28.5 kg). To lift the system, use two people or a hydraulic lift.

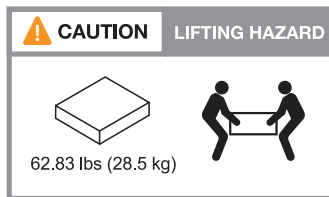

ASA A70 and ASA A90

An ASA A70 storage system or an ASA A90 storage system can weigh up to 151.68 lbs (68.8 kg). To lift the system, use four people or a hydraulic lift.

Storage shelf weight

An NS224 storage shelf can weigh up to 66.78 lbs (30.29 kg). To lift the storage shelf, use two people or a hydraulic lift. Keep all components in the storage shelf (both front and rear) to prevent unbalancing the shelf weight.

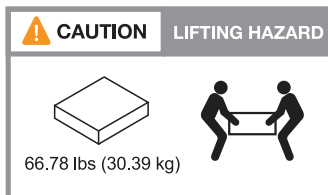

Related information

- [Safety information and regulatory notices](#)

What's next?

After you've reviewed the hardware requirements, you [prepare to install your ASA r2 storage system](#).

Prepare to install an ASA r2 storage system

Prepare to install your ASA r2 storage system by getting the site ready, unpacking the boxes and comparing the contents of the boxes to the packing slip, and registering the system to access support benefits.

Step 1: Prepare the site

To install your ASA r2 storage system, ensure that the site and the cabinet or rack that you plan to use meet specifications for your configuration.

Steps

1. Use [NetApp Hardware Universe](#) to confirm that your site meets the environmental and electrical requirements for your ASA r2 storage system.
2. Make sure you have adequate rack space:
 - 4U in an HA configuration for the storage system
 - 2U for each NS224 storage shelf
3. Install any required network switches.

See the [Switch documentation](#) for installation instructions and [NetApp Hardware Universe](#) for compatibility information.

Step 2: Unpack the boxes

After you've ensured that the site and the cabinet or rack that you plan to use for your ASA r2 storage system meet the required specifications, unpack all boxes and compare the contents to the items on the packing slip.

Steps

1. Carefully open all the boxes and lay out the contents in an organized manner.
2. Compare the contents you've unpacked with the list on the packing slip.



You can get your packing list by scanning the QR code on the side of the shipping carton.

The following items are some of the contents you might see in the boxes.

Ensure that everything in the boxes matches the list on the packing slip. If there are any discrepancies, note them down for further action.

Hardware

- Bezel
- Cable management device
- Storage system
- Rail kits with instructions (optional)
- Storage shelf

Cables

- Management Ethernet cables (RJ-45 cables)
- Network cables
- Power cords
- Storage cables (if you ordered additional storage)
- USB-C serial port cable

Step 3: Register your storage system

After you've ensured that your site meets the requirements for your ASA r2 storage system specifications, and you've verified that you have all the parts you ordered, you should register your system.

Steps

1. Locate the serial number for your storage system.

You can find the number on the packing slip, in your confirmation email, or on the controller's System Management module after you unpack it.



2. Go to the [NetApp Support Site](#).
3. Determine whether you need to register your storage system:

If you are a...	Follow these steps...
Existing NetApp customer	<ol style="list-style-type: none">a. Sign in with your username and password.b. Select Systems > My Systems.c. Confirm that the new serial number is listed.d. If it is not, follow the instructions for new NetApp customers.
New NetApp customer	<ol style="list-style-type: none">a. Click Register Now, and create an account.b. Select Systems > Register Systems.c. Enter the storage system's serial number and requested details. <p>After your registration is approved, you can download any required software. The approval process might take up to 24 hours.</p>

What's next?

After you've prepared to install your ASA r2 hardware, you [install the hardware for your ASA r2 storage system](#).

Install your ASA r2 storage system

After you prepare to install your ASA r2 storage system, install the hardware for the system. First, install the rail kits. Then install and secure your storage system in a cabinet or telco rack.

Before you begin

- Make sure you have the instructions packaged with the rail kit.
- Be aware of the safety concerns associated with the weight of the storage system and storage shelf.
- Understand that the airflow through the storage system enters from the front where the bezel or end caps are installed and exhausts out the rear where the ports are located.

Steps

1. Install the rail kits for your storage system and storage shelves, as needed, using the instructions included with the kits.
2. Install and secure your storage system in the cabinet or telco rack:
 - a. Position the storage system onto the rails in the middle of the cabinet or telco rack, and then support the storage system from the bottom and slide it into place.
 - b. Secure the storage system to the cabinet or telco rack using the included mounting screws.
3. Install the storage shelf:
 - a. Position the back of the storage shelf onto the rails, and then support the shelf from the bottom and slide it into the cabinet or telco rack.

If you are installing multiple storage shelves, place the first storage shelf directly above the controllers. Place the second storage shelf directly under the controllers. Repeat this pattern for any additional storage shelves.

 - b. Secure the storage shelf to the cabinet or telco rack using the included mounting screws.
4. Attach the cable management devices to the rear of the storage system.

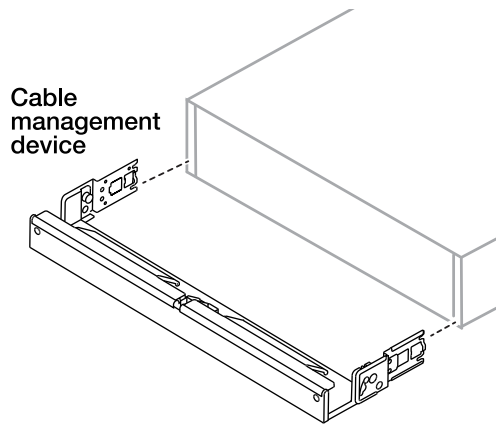

5. Attach the bezel to the front of the storage system.

What's next?

After you've installed the hardware for your ASA r2 system, you [cable the controllers and storage shelves for your ASA r2 system](#).

Cable the hardware for your ASA r2 storage system

After you install the rack hardware for your ASA r2 storage system, install the network cables for the controllers, and connect the cables between the controllers and storage shelves.

Before you begin

Check the illustration arrow in the cabling diagrams for the proper cable connector pull-tab orientation.

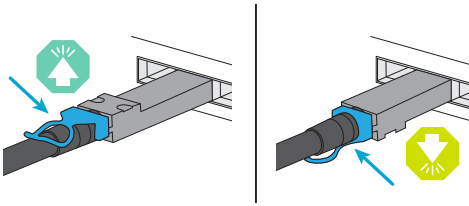

- As you insert the connector, you should feel it click into place; if you do not feel it click, remove it, turn the cable head over and try again.
- If connecting to an optical switch, insert the small form-factor pluggable (SFP) transceiver into the controller port before cabling to the port.

Step 1: Connect the storage controllers to your network

Connect your controllers directly to each other and to your host network.

Before you begin

Contact your network administrator for information about connecting your storage system to the host network switches.

About this task

These procedures show common configurations. The specific cabling depends on the components ordered for your storage system. For comprehensive configuration and slot priority details, see [NetApp Hardware Universe](#).

ASA A1K

Connect your storage controllers to each other to create the ONTAP cluster connections, and then connect the Ethernet ports on each controller to your host network.

Steps

1. Use the Cluster/HA interconnect cable to connect ports e1a to e1a and ports e7a to e7a.



The cluster interconnect traffic and the HA traffic share the same physical ports.

- a. Connect port e1a on Controller A to port e1A on Controller B.
- b. Connect port e7a on Controller A to port e1A on Controller B.

Cluster/HA interconnect cables

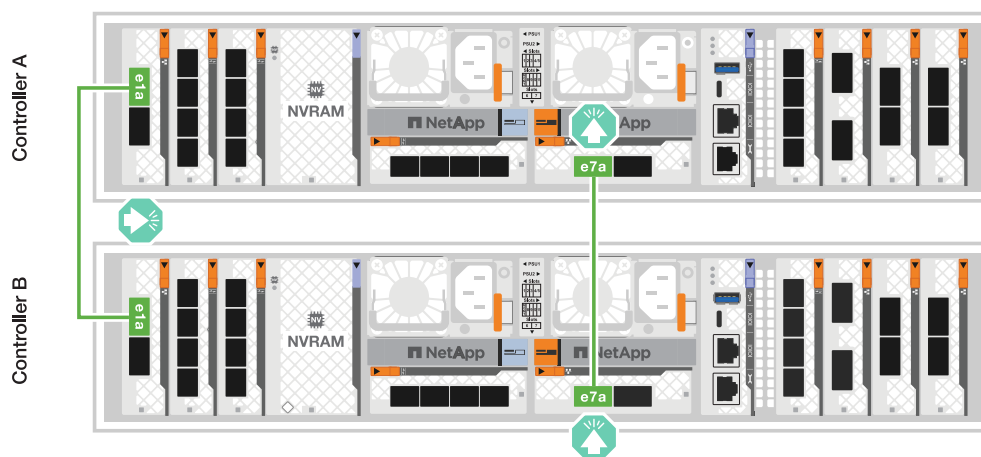

2. Connect the Ethernet module ports to your host network.

The following are some typical host network cabling examples. See [NetApp Hardware Universe](#) for your specific system configuration.

- a. Connect ports e9a and e9b to your Ethernet data network switch as shown.



For maximum system performance for cluster and HA traffic, do not use ports e1b and e7b ports for host network connections. Use a separate host card to maximize performance.

100 GbE cable



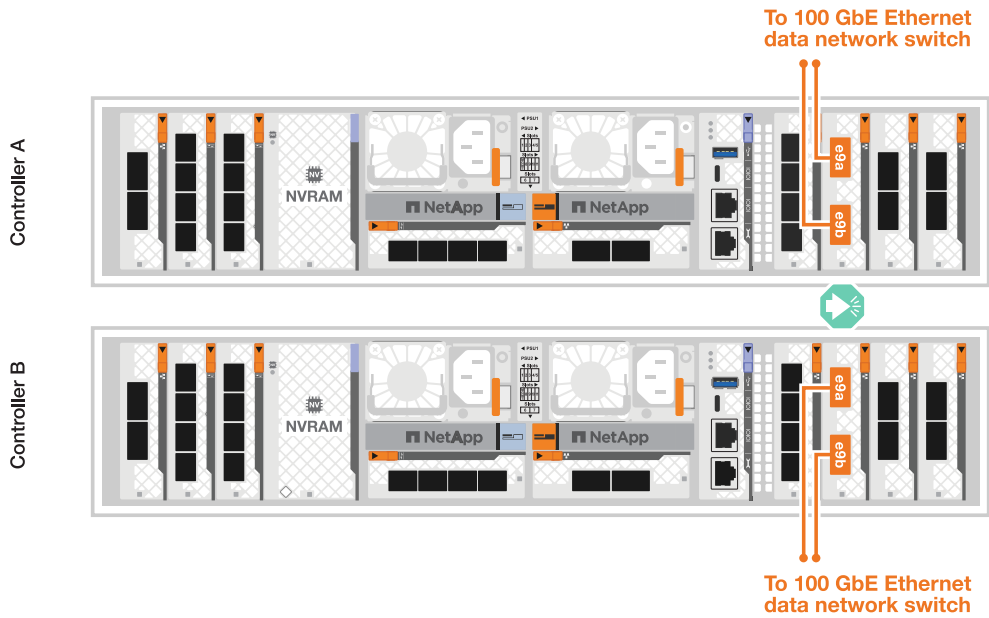

b. Connect your 10/25 GbE host network switches.

10/25 GbE Host

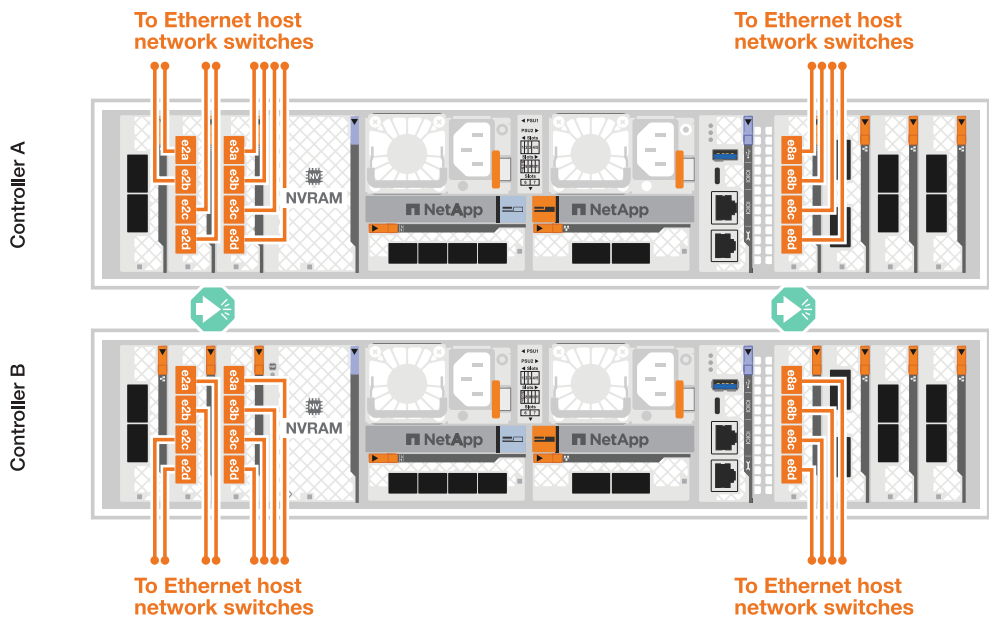

3. Use the 1000BASE-T RJ-45 cables to connect the controller management (wrench) ports to the management network switches.



1000BASE-T RJ-45 cables

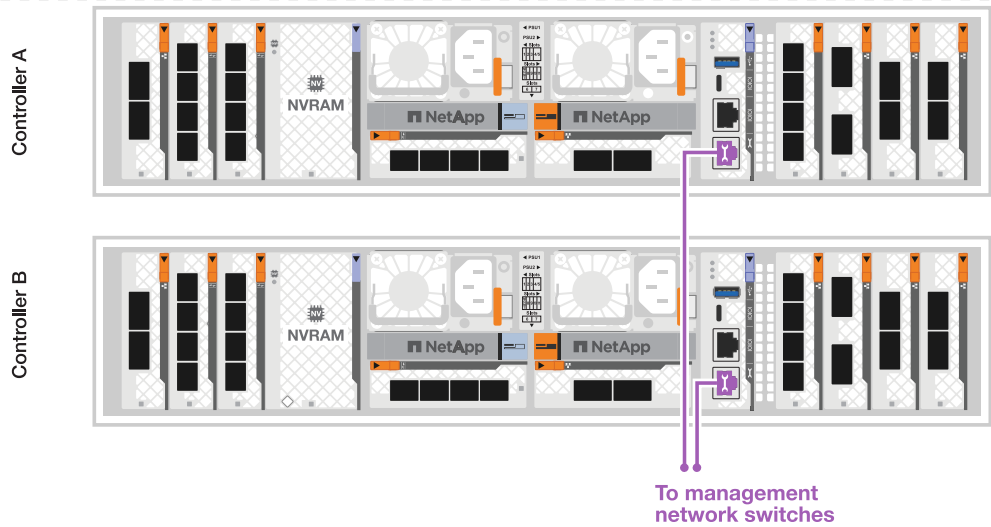

 Do not plug in the power cords yet.

ASA A70 and ASA A90

Connect your storage controllers to each other to create the ONTAP cluster connections, and then connect the Ethernet ports on each controller to your host network.

Steps

1. Use the the Cluster/HA interconnect cable to connect to connect ports e1a to e1a and ports e7a to e7a.

 The cluster interconnect traffic and the HA traffic share the same physical ports.

- a. Connect port e1a on Controller A to port e1A on Controller B.
- b. Connect port e7a on Controller A to port e1A on Controller B.

Cluster/HA interconnect cables

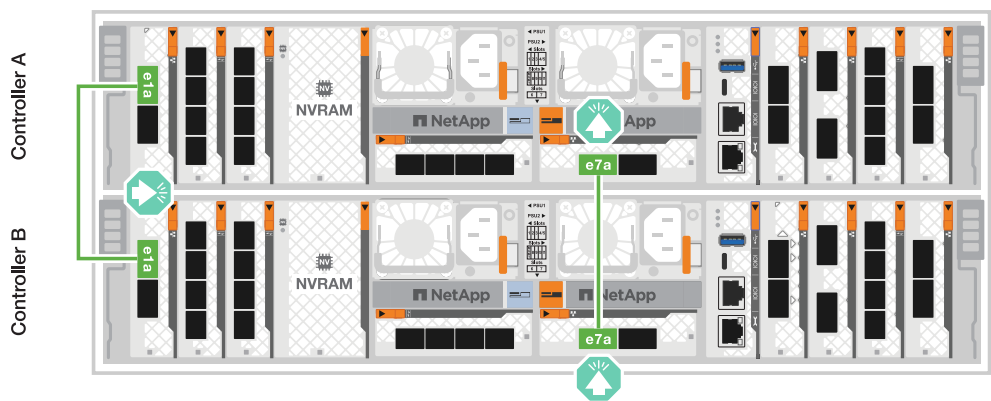

2. Connect the Ethernet module ports to your host network.

The following are some typical host network cabling examples. See [NetApp Hardware Universe](#) for your specific system configuration.

a. Connect ports e9a and e9b to your Ethernet data network switch as shown.



For maximum system performance for cluster and HA traffic, do not use ports e1b and e7b ports for host network connections. Use a separate host card to maximize performance.

100 GbE cable

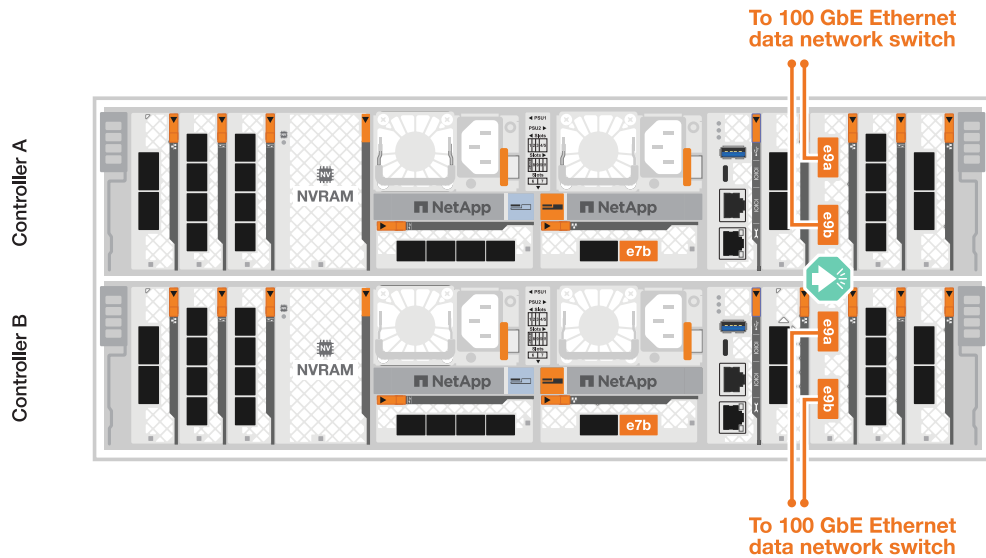

b. Connect your 10/25 GbE host network switches.

4-ports, 10/25 GbE Host

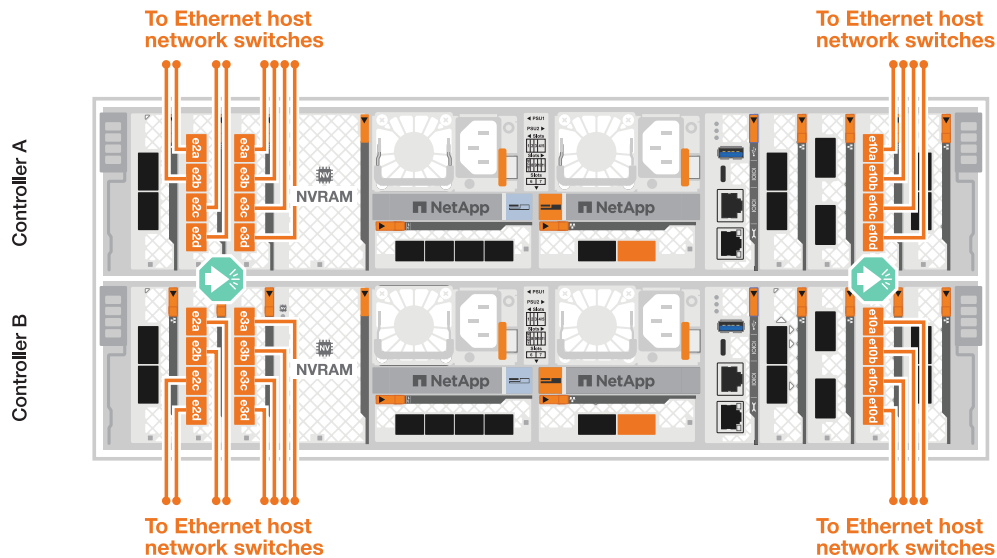

3. Use the 1000BASE-T RJ-45 cables to connect the controller management (wrench) ports to the management network switches.



1000BASE-T RJ-45 cables

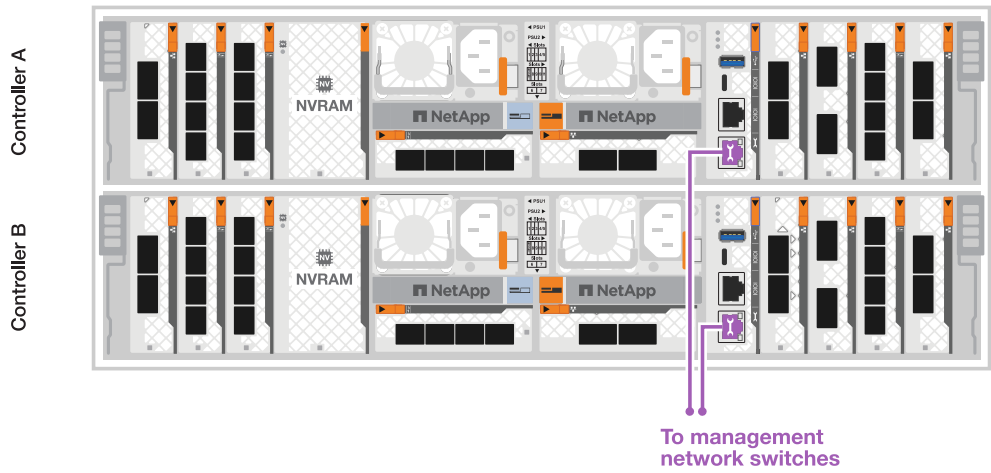

Do not plug in the power cords yet.

Step 2: Connect the storage controllers to the storage shelves

The following cabling procedures show how to connect your controllers to one shelf and to two shelves. You can directly connect up to four shelves to your controllers.

ASA A1K

Choose one of the following cabling options that matches your setup.

Option 1: Connect the controllers to one NS224 storage shelf

Connect each controller to the NSM modules on the NS224 shelf. The graphics show cabling from each of the controllers: Controller A cabling is shown in blue and Controller B cabling is shown in yellow.

Steps

1. On controller A, connect the following ports:
 - a. Connect port e11a to NSM A port e0a.
 - b. Connect port e11b to port NSM B port e0b.

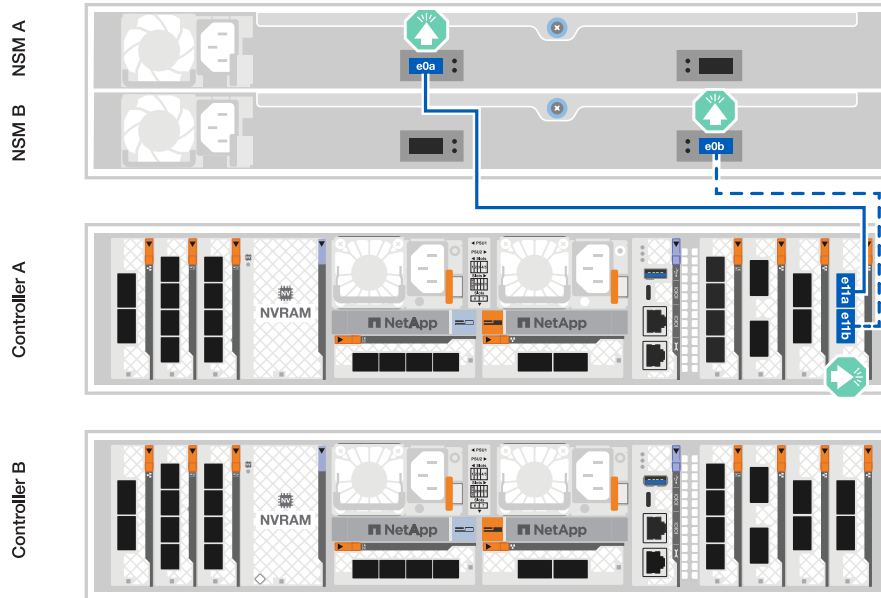

2. On controller B, connect the following ports:
 - a. Connect port e11a to NSM B port e0a.
 - b. Connect port e11b to NSM A port e0b.

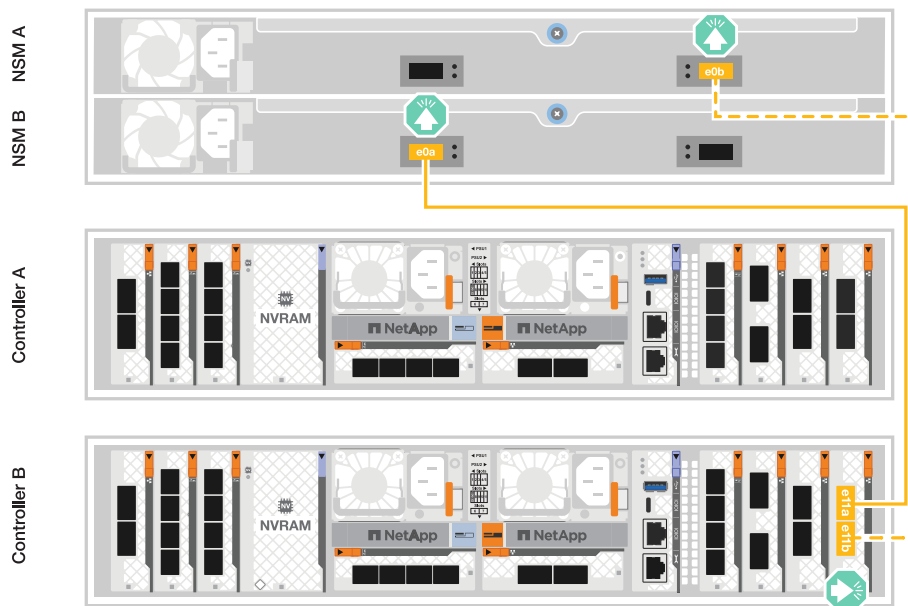

Option 2: Connect the controllers to two NS224 storage shelves

Connect each controller to the NSM modules on both NS224 shelves. The graphics show cabling from each of the controllers: Controller A cabling is shown in blue and Controller B cabling is shown in yellow.

Steps

1. On controller A, connect the following ports:
 - a. Connect port e11a to shelf 1 NSM A port e0a.
 - b. Connect port e11b to shelf 2 NSM B port e0b.
 - c. Connect port e10a to shelf 2 NSM A port e0a.
 - d. Connect port e10b to shelf 1 NSM A port e0b.

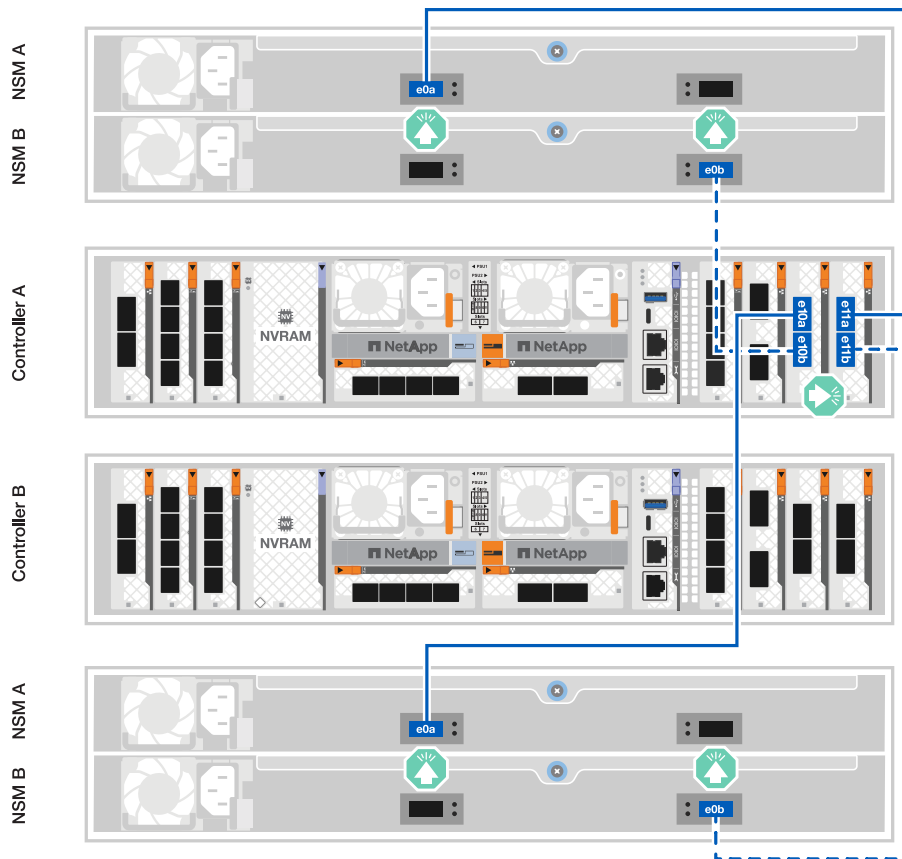

2. On controller B, connect the following ports:
 - a. Connect port e11a to shelf 1 NSM B port e0a.
 - b. Connect port e11b to shelf 2 NSM A port e0b.
 - c. Connect port e10a to shelf 2 NSM B port e0a.
 - d. Connect port e10b to shelf 1 NSM A port e0b.

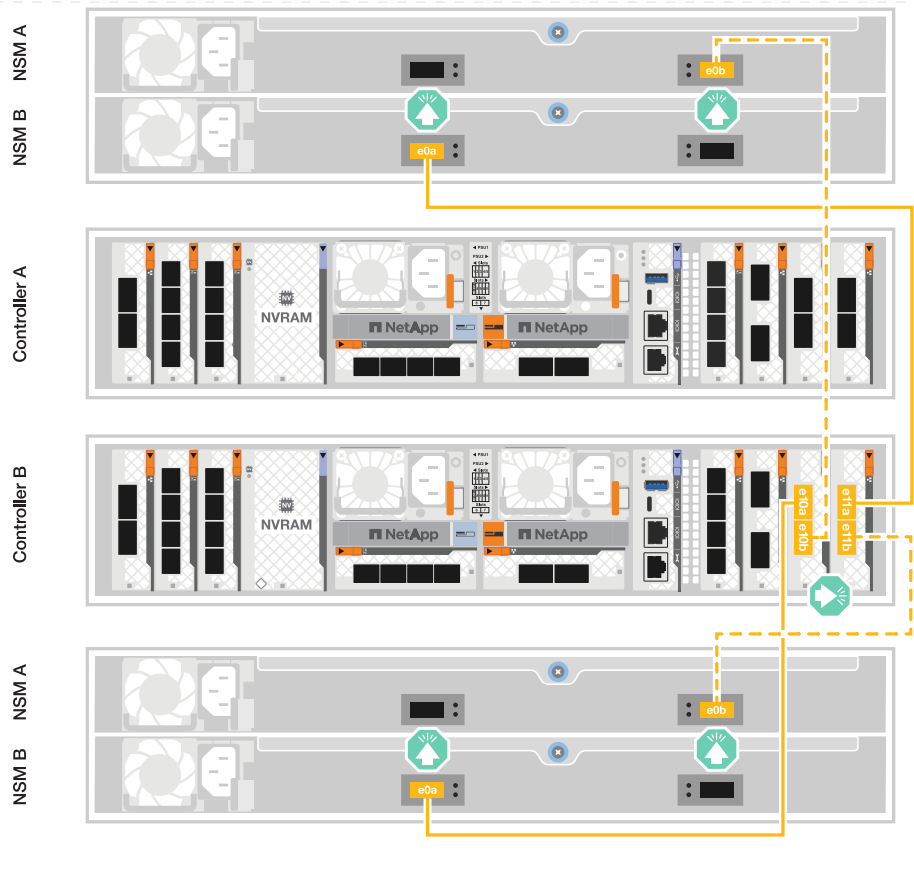

ASA A70 and ASA A90

Choose one of the following cabling options that matches your setup.

Option 1: Connect the controllers to one NS224 storage shelf

Connect each controller to the NSM modules on the NS224 shelf. The graphics show cabling from each of the controllers: Controller A cabling is shown in blue and Controller B cabling is shown in yellow.

100 GbE QSFP28 copper cables



Steps

1. Connect controller A port e11a to NSM A port e0a.
2. Connect controller A port e11b to port NSM B port e0b.

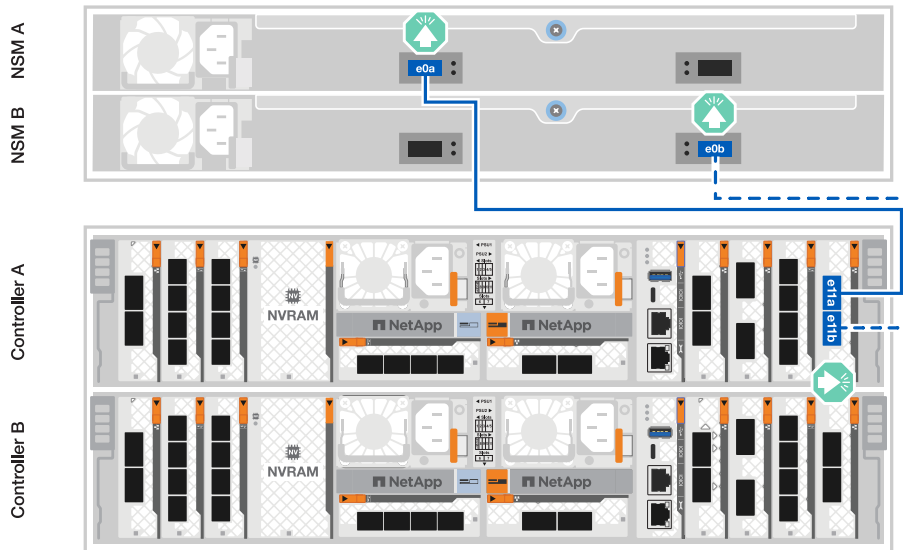

3. Connect controller B port e11a to NSM B port e0a.
4. Connect controller B port e11b to NSM A port e0b.

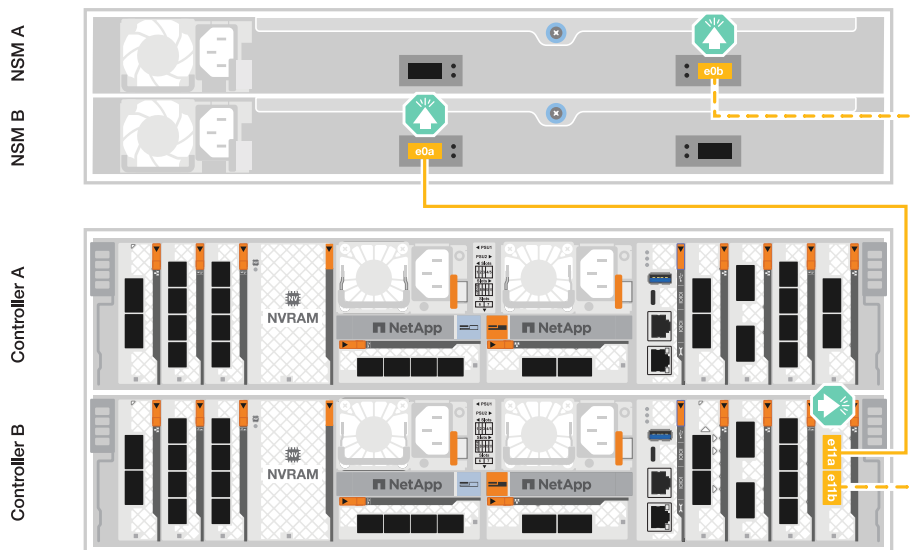

Option 2: Connect the controllers to two NS224 storage shelves

Connect each controller to the NSM modules on both NS224 shelves. The graphics show cabling from each of the controllers: Controller A cabling is shown in blue and Controller B cabling is shown in yellow.

100 GbE QSFP28 copper cables



Steps

1. On controller A, connect the following ports:
 - a. Connect port e11a to shelf 1, NSM A port e0a.
 - b. Connect port e11b to shelf 2, NSM B port e0b.
 - c. Connect port e8a to shelf 2, NSM A port e0a.
 - d. Connect port e8b to shelf 1, NSM B port e0b.

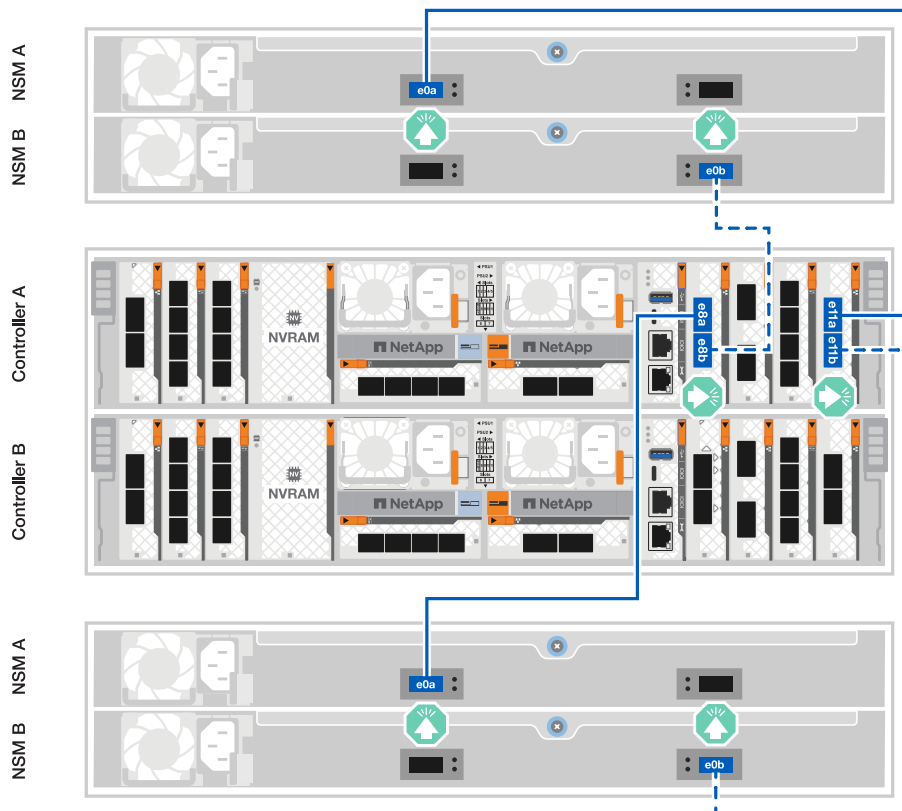

2. On controller B, connect the following ports:
 - a. Connect port e11a to shelf 1, NSM B port e0a.
 - b. Connect port e11b to shelf 2, NSM A port e0b.
 - c. Connect port e8a to shelf 2, NSM B port e0a.
 - d. Connect port e8b to shelf 1, NSM A port e0b.

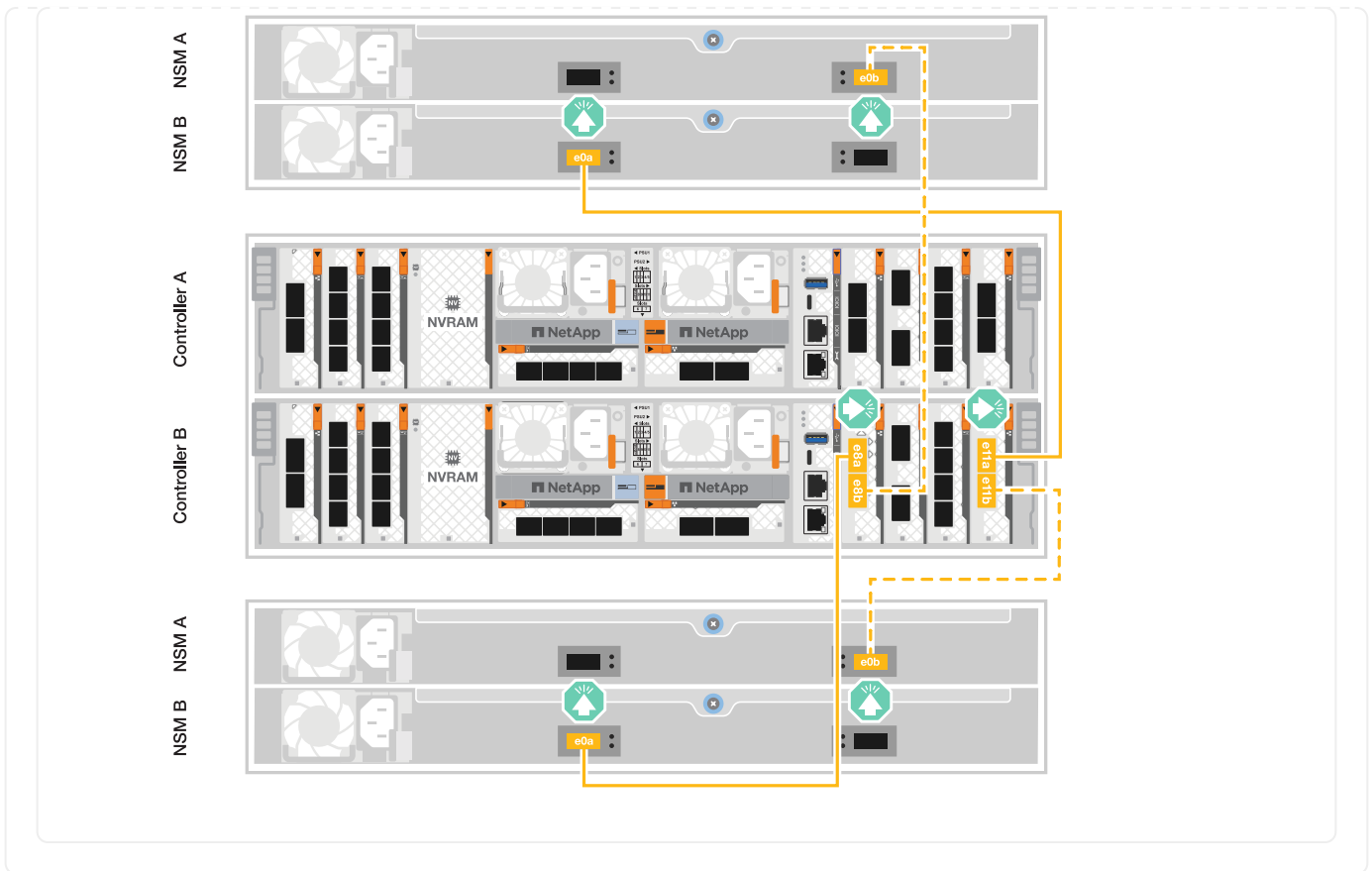

What's next?

After you've connected the storage controllers to your network and then connected the controllers to your storage shelves, you [power on the ASA r2 storage system](#).

Power on your ASA r2 storage system

After you install the rack hardware for your ASA r2 storage system and install the cables for the controllers and storage shelves, you should power on your storage shelves and controllers.

Step 1: Power on the shelf and assign shelf ID

Each NS224 shelf is distinguished by a unique shelf ID. This ID ensures that the shelf is distinct within your storage system setup. By default, shelf IDs are assigned as '00' and '01', but you may need to adjust these IDs to maintain uniqueness across your storage system.

About this task

- A valid shelf ID is 00 through 99.
- You must power cycle a shelf (unplug both power cords, wait the appropriate amount of time, and then plug them back in) for the shelf ID to take effect.

Steps

1. Power on the shelf by connecting the power cords first to the shelf, securing them in place with the power cord retainer, and then connecting the power cords to power sources on different circuits.

The shelf powers on and boots automatically when plugged into the power source.

2. Remove the left end cap to access the shelf ID button behind the faceplate.

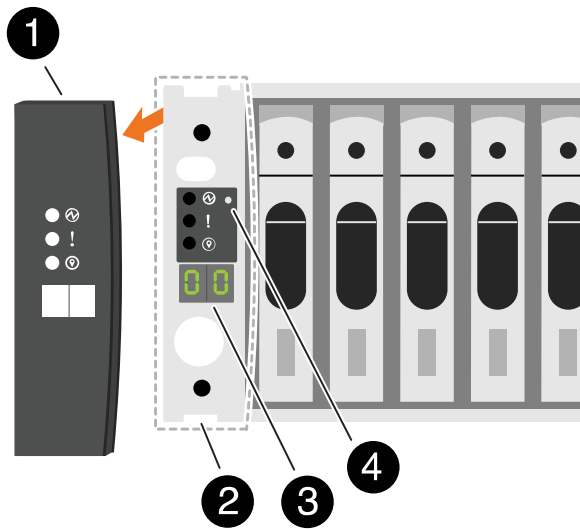

1	Shelf end cap
2	Shelf faceplate
3	Shelf ID number
4	Shelf ID button

3. Change the first number of the shelf ID:

- Insert the straightened end of a paperclip or narrow tipped ball point pen into the small hole to press the shelf ID button.
- Press and hold the shelf ID button until the first number on the digital display blinks, and then release the button.

It can take up to 15 seconds for the number to blink. This activates the shelf ID programming mode.



If the ID takes longer than 15 seconds to blink, press and hold the shelf ID button again, making sure to press it in all the way.

- Press and release the shelf ID button to advance the number until you reach the desired number from 0 to 9.

Each press and release duration can be as short as one second.

The first number continues to blink.

4. Change the second number of the shelf ID:

- Press and hold the button until the second number on the digital display blinks.

It can take up to three seconds for the number to blink.

The first number on the digital display stops blinking.

- b. Press and release the shelf ID button to advance the number until you reach the desired number from 0 to 9.

The second number continues to blink.

5. Lock in the desired number and exit the programming mode by pressing and holding the shelf ID button until the second number stops blinking.

It can take up to three seconds for the number to stop blinking.

Both numbers on the digital display start blinking and the amber LED illuminates after about five seconds, alerting you that the pending shelf ID has not yet taken effect.

6. Power-cycle the shelf for at least 10 seconds to make the shelf ID take effect.

- a. Unplug the power cord from both power supplies on the shelf.
- b. Wait 10 seconds.
- c. Plug the power cords back into the shelf power supplies to complete the power cycle.

A power supply is powered on as soon as the power cord is plugged in. Its bicolored LED should illuminate green.

7. Replace the left end cap.

Step 2: Power on the controllers

After you've turned on your storage shelves and assigned them unique IDs, turn on the power to the storage controllers.

Steps

1. Connect your laptop to the serial console port. This will allow you to monitor the boot sequence when the controllers are turned on.
 - a. Set the serial console port on the laptop to 115,200 baud with N-8-1.



See your laptop's online help for instructions on how to configure the serial console port.

- b. Connect the console cable to the laptop, and connect the serial console port on the controller using the console cable that came with your storage system.
- c. Connect the laptop to the switch on the management subnet.

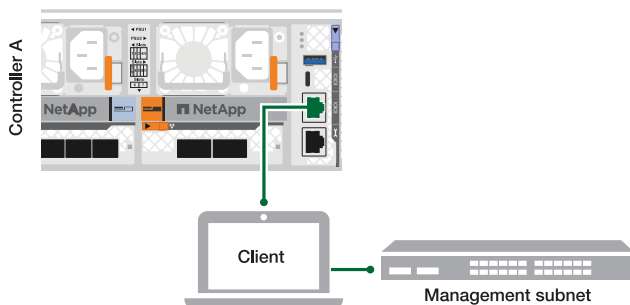

- d. Assign a TCP/IP address to the laptop, using one that is on the management subnet.
2. Plug the power cords into the controller power supplies, and then connect them to power sources on different circuits.

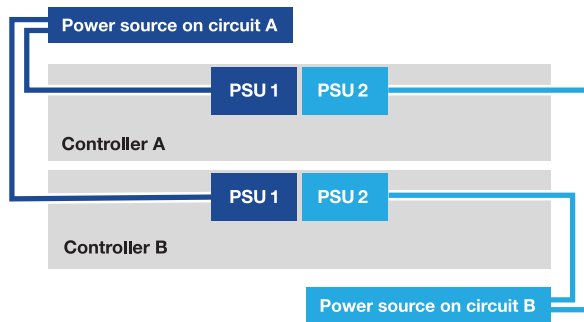

- The storage system begins to boot. Initial booting may take up to eight minutes.
 - The LEDs flash on and the fans start, which indicates that the controllers are powering on.
 - The fans might be very noisy when they first start up. The fan noise during start-up is normal.
3. Secure the power cables using the securing device on each power supply.

What's next?

After you've turned on your ASA r2 storage system, you [set up an ONTAP ASA r2 cluster](#).

Copyright information

Copyright © 2024 NetApp, Inc. All Rights Reserved. Printed in the U.S. No part of this document covered by copyright may be reproduced in any form or by any means—graphic, electronic, or mechanical, including photocopying, recording, taping, or storage in an electronic retrieval system—without prior written permission of the copyright owner.

Software derived from copyrighted NetApp material is subject to the following license and disclaimer:

THIS SOFTWARE IS PROVIDED BY NETAPP “AS IS” AND WITHOUT ANY EXPRESS OR IMPLIED WARRANTIES, INCLUDING, BUT NOT LIMITED TO, THE IMPLIED WARRANTIES OF MERCHANTABILITY AND FITNESS FOR A PARTICULAR PURPOSE, WHICH ARE HEREBY DISCLAIMED. IN NO EVENT SHALL NETAPP BE LIABLE FOR ANY DIRECT, INDIRECT, INCIDENTAL, SPECIAL, EXEMPLARY, OR CONSEQUENTIAL DAMAGES (INCLUDING, BUT NOT LIMITED TO, PROCUREMENT OF SUBSTITUTE GOODS OR SERVICES; LOSS OF USE, DATA, OR PROFITS; OR BUSINESS INTERRUPTION) HOWEVER CAUSED AND ON ANY THEORY OF LIABILITY, WHETHER IN CONTRACT, STRICT LIABILITY, OR TORT (INCLUDING NEGLIGENCE OR OTHERWISE) ARISING IN ANY WAY OUT OF THE USE OF THIS SOFTWARE, EVEN IF ADVISED OF THE POSSIBILITY OF SUCH DAMAGE.

NetApp reserves the right to change any products described herein at any time, and without notice. NetApp assumes no responsibility or liability arising from the use of products described herein, except as expressly agreed to in writing by NetApp. The use or purchase of this product does not convey a license under any patent rights, trademark rights, or any other intellectual property rights of NetApp.

The product described in this manual may be protected by one or more U.S. patents, foreign patents, or pending applications.

LIMITED RIGHTS LEGEND: Use, duplication, or disclosure by the government is subject to restrictions as set forth in subparagraph (b)(3) of the Rights in Technical Data -Noncommercial Items at DFARS 252.227-7013 (FEB 2014) and FAR 52.227-19 (DEC 2007).

Data contained herein pertains to a commercial product and/or commercial service (as defined in FAR 2.101) and is proprietary to NetApp, Inc. All NetApp technical data and computer software provided under this Agreement is commercial in nature and developed solely at private expense. The U.S. Government has a non-exclusive, non-transferrable, nonsublicensable, worldwide, limited irrevocable license to use the Data only in connection with and in support of the U.S. Government contract under which the Data was delivered. Except as provided herein, the Data may not be used, disclosed, reproduced, modified, performed, or displayed without the prior written approval of NetApp, Inc. United States Government license rights for the Department of Defense are limited to those rights identified in DFARS clause 252.227-7015(b) (FEB 2014).

Trademark information

NETAPP, the NETAPP logo, and the marks listed at <http://www.netapp.com/TM> are trademarks of NetApp, Inc. Other company and product names may be trademarks of their respective owners.