



3040 40U cabinet

e-series

NetApp
May 03, 2022

Table of Contents

- 3040 40U cabinet 1
- Install trays in the 3040 40U cabinet 1
- Cabinet specifications 1
- Gather required tools and equipment 5
- Prepare to move cabinet 7
- Move cabinet to its permanent location 10
- Complete cabinet installation 11

3040 40U cabinet

Install trays in the 3040 40U cabinet

You can install the following controller-drive trays and expansion drive trays in the E-Series 3040 40U cabinet:

- E2612, E2624, and E2660 controller-drive trays
- E2712, E2724, and E2760 controller-drive trays
- E5412, E5424, and E5460 controller-drive trays
- E5512, E5524, and E5560 controller-drive trays
- E5612, E5624, and E5660 controller-drive trays
- EF540, EF550, and EF560 flash arrays
- DE1600, DE5600, and DE6600 drive trays

You can also install the following SAS-3 controller shelves and drive shelves in the cabinet.

- E2812, E2824, and E5724 controller shelves
- DE212C and DE224C drive shelves

However, specifications for these shelves are not listed in these procedures. Refer to [NetApp Hardware Universe](#).

Cabinet specifications

The model 3040 40U cabinet has these standard features:

- A rear door that can be latched and locked
- Standard Electronic Industry Association (EIA) support rails that provide mounting holes for installing devices into a standard 48.3-cm (19-in.) wide cabinet
- Four roller casters and four adjustable leveling feet that are located beneath the cabinet for moving the cabinet and then leveling the cabinet in its final location
- A stability foot that stabilizes the cabinet after it is installed in its permanent location
- Access openings for interface cables
- Two AC power distribution units (PDUs) that provide integrated power connection and power handling capacity

The following figures show a front view (left) and a rear view (right) of the cabinet.

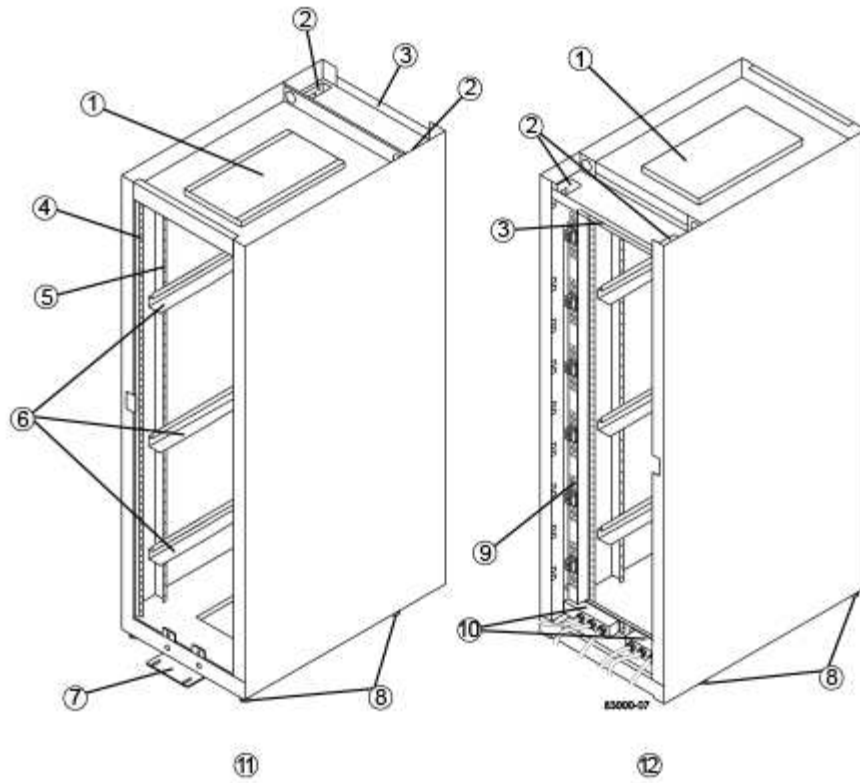

1.	Ventilation cover
2.	Interface cable access openings
3.	Rear plate
4.	EIA support rails
5.	Vertical support rails
6.	Cabinet mounting rails
7.	Stability foot
8.	Adjustable leveling feet
9.	Power distribution unit (one of two)
10.	AC power entry boxes
11.	Front of the cabinet
12.	Rear of the cabinet



Risk of bodily injury — If the bottom half of the cabinet is empty, do not install components in the top half of the cabinet. If the top half of the cabinet is too heavy for the bottom half, the cabinet might fall and cause bodily injury. Always install a component in the lowest available position in the cabinet.



Risk of bodily injury — Only move a populated cabinet with a forklift or adequate help from other persons. Always push the cabinet from the front to prevent it from falling over. A fully populated cabinet can weigh more than 2000 lb (909 kg). The cabinet is difficult to move, even on a flat surface. If you must move the cabinet along an inclined surface, remove the components from the top half of the cabinet, and make sure that you have adequate help.



You cannot install E2860 or E5760 controller shelves or a DE460C drive shelf into a 3040 40U cabinet.



If a 3040 cabinet is fully populated with DE6600 trays, it weighs more than 2756 lb (1250.1 kg).

Power requirements and heat dissipation

The cabinet includes the following specifications for power and heat dissipation.

Power rating

The 3040 40U cabinet is rated at 200 VAC to 240 VAC at 50 Hz to 60 Hz, and operates to ± 10 percent of that range.

Power distribution units (PDUs)

The cabinet includes two identical AC power distribution units (PDUs), with each PDU providing up to 72A of usable power. The PDUs are mounted vertically at the back of the cabinet, and each PDU includes six 12A power banks. Each power bank contains four IEC 60320-C19 power outlets and a 15A circuit breaker. Each PDU has a total of 24 outlets and 6 circuit breakers.

Each of the two PDUs has three power entry boxes, which are located at the bottom of the cabinet. Each power entry box provides power to eight of the power outlets, as follows:

- Power entry box 1, which has power cord C1, supplies power to the bottom eight outlets
- Power entry box 2, which has power cord C2, supplies power to the middle eight outlets
- Power entry box 3, which has power cord C3, supplies power to the top eight outlets

The power entry boxes are labeled C1, C2, and C3 where the power cords connect to the modules.

Power calculations and heat calculations for the cabinet

Component	kVA	Watts	BTU/Hr
Cabinet PDU (72A PDUs)	14.4	14400	49176
Cabinet PDU/12A bank (72A PDUs)	2.40*	2400*	8196*

Component	kVA	Watts	BTU/Hr
E2612 controller-drive tray	0.437	433	1476
E2624 controller-drive tray	0.487	482	1644
E2660 controller-drive tray	1.128	1117	3810
E2712 controller-drive tray	0.516	511	1744
E2724 controller-drive tray	0.561	555	1894
E2760 controller-drive tray	1.205	1193	4072
E5412 controller-drive tray	0.558	552	1883
E5424 controller-drive tray and the EF540 flash array	0.607	601	2051
E5460 controller-drive tray	1.254	1242	4237
E5512 controller-drive tray	0.587	581	1982
E5524 controller-drive tray and the EF550 flash array	0.637	630	2150
E5560 controller-drive tray	1.285	1272	4342
E5612 controller-drive tray	0.625	619	2111
E5624 controller-drive tray and the EF560 flash array	0.675	668	2279

Component	kVA	Watts	BTU/Hr
E5660 controller-drive tray	1.325	1312	4477
DE1600 drive tray	0.325	322	1099
DE5600 drive tray	0.375	371	1267
DE6600 drive tray	0.1.011	1001	3415

Maximum number of trays

The maximum number of trays that you can install in a 3040 40U cabinet depends on the height of each tray in rack units (U).

Tray heights in rack units (U)

Each rack unit is 1.75 inches (4.45 cm). For example, you can install up to ten 4U trays, up to twenty 2U trays, or a combination of 2U and 4U trays, up to 40U.





Tray	Rack units (U)
E2x12 or E2x24 controller-drive tray	2U
E2x60 controller-drive tray	4U
E5x12 or E5x24 controller-drive tray	2U
E5x60 controller-drive tray	4U
EF5x0 Flash Array	2U
DE1600 drive tray	2U
DE5600 drive tray	2U
DE6600 drive tray	4U

Gather required tools and equipment

Before installing the 3040 40U cabinet, make sure you have required tools and equipment.

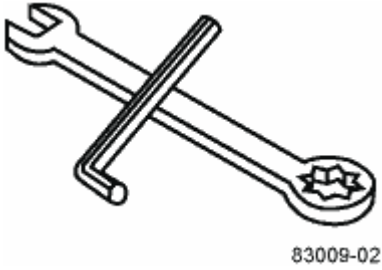
Step

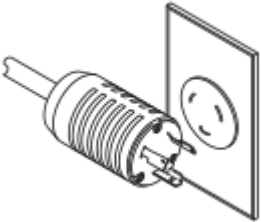
1. Gather all items listed in the following table.

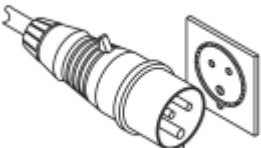
	Item	Included with the cabinet
 <p>83009-02</p>	<p>3/4-in. wrench (supplied in the shipping crate) — To raise and lower the leveling feet under the cabinet.</p> <p>1/4-in. Allen wrench — To raise and lower the stability foot in the front of the cabinet.</p>	
<p>NEMA L6-30</p> 	<p>AC power cords — To connect the cabinet to external power sources (wall plugs).</p> <ul style="list-style-type: none"> • The NEMA L6-30 connectors are for use in the USA and Canada. • The IEC-60309 connectors are for use worldwide, except for USA and Canada. <div style="border: 1px solid black; padding: 5px; margin-top: 10px;">  <p>Each PDU must be connected to an independent power source.</p> </div>	
<p>IEC-60309</p> 		<p>SAS cables (optional) – Two cables are included with each drive tray, while host side cables must be purchased separately.</p> <p>Communication cables (optional) – To attach the tray to the host.</p> <p>Refer to the appropriate controller-drive tray installation guide for additional required items.</p>

	Item	Included with the cabinet
	Mountable cable spools – Installed along both sides of the vertical power distribution outlets to accommodate excess cable length and cable routing. Two cable spools are included with each controller-drive tray. Cable spools are also shipped with standalone drive trays.	✓
	Shears – To cut the metal bands on the shipping crate.	
	Forklift (optional) – To remove the cabinet from the shipping pallet.	
	Front panel kits (optional) – To cover the empty bays at the front of the cabinet.	
	Antistatic bags (optional) – To protect components that are removed during the installation procedure for the cabinet.	

Prepare to move cabinet

Prepare to move the cabinet from its location in your receiving area by estimating its total weight, acclimating the cabinet, removing the packing materials, and checking the shipping contents.

Step 1: Estimate cabinet weight

The cabinet reliably and safely transports up to 909.1 kg (2000 lb) of capacity. You need to know the approximate weight of the cabinet so that you can safely move it.

Steps

1. Use the following table to calculate the approximate total weight of your cabinet.

The total weight of the cabinet depends on the number and type of trays that are installed in the cabinet.

Component	Weight	Notes
Cabinet	138.80 kg (306.0 lb)	Empty with the rear door installed

Component	Weight	Notes
Power distribution units (PDUs [pair])	19.96 kg (44.0 lb)	
Mounting rails (pair)	1.59 kg (3.50 lb)	
E2612 controller-drive tray	27 kg (59.52 lb)	Maximum configuration
E2624 controller-drive tray	26.12 kg (57.32 lb)	Maximum configuration
E2660 controller-drive tray	105.2 kg (232 lb)	Maximum configuration
E2712 controller-drive tray	27.12 kg (59.8 lb)	Maximum configuration
E2724 controller-drive tray	26 kg (57.32 lb)	Maximum configuration
E2760 controller-drive tray	105.2 kg (232 lb)	Maximum configuration
E5412 controller-drive tray	27.92 (61.52 lb)	Maximum configuration
E5424 controller-drive tray	26.92 kg (59.32 lb)	Maximum configuration
E5460 controller-drive tray	105.2 kg (232 lb)	Maximum configuration
E5512 controller-drive tray	28.89 kg (63.7 lb)	Maximum configuration
E5524 controller-drive tray	27.9 kg (61.52 lb)	Maximum configuration
E5560 controller-drive tray	107.13 kg (236.2 lb)	Maximum configuration
E5612 controller-drive tray	28.89 kg (63.7 lb)	Maximum configuration
E5624 controller-drive tray	27.9 kg (61.52 lb)	Maximum configuration
E5660 controller-drive tray	107.13 kg (236.2 lb)	Maximum configuration
EF540 flash array	23.64 kg (52.12 lb)	Maximum configuration
EF550 flash array	24.63 kg (54.32 lb)	Maximum configuration
EF560 flash array	24.63 kg (54.32 lb)	Maximum configuration
DE1600 drive tray	26.3 kg (58 lb)	Maximum configuration

Component	Weight	Notes
DE5600 drive tray	25.31 kg (55.8 lb)	Maximum configuration
DE6600 drive tray	104.1 kg (229.6 lb)	Maximum configuration

2. Review the following notes.



Remove all drives from the DE6600 drive tray before moving the cabinet to its final position.



Possible equipment damage — Cabinets with DE6600 drive trays ship without drives to reduce shipping weight. Because a fully-populated cabinet with DE6600 drive trays can weigh more than 1247.3 kg (2750 lb), make sure that you move the cabinet into place before you load the drives, and make sure that the floor load capability of the cabinet's destination supports that much weight.



Possible damage to tray components — Do not place a DE6600 drive tray on a flat surface. Install the DE6600 drive tray in the cabinet before operating or moving drawers.

Step 2: Acclimate cabinet

Make sure that the cabinet and the trays are acclimated to the indoor environment before removing the packing materials.

Steps

1. If the outdoor temperature is below 0°C (32°F), leave the cabinet and trays inside of their crates indoors for at least 24 hours to prevent condensation.
2. Increase or decrease the 24-hour stabilization period depending on the outside temperature upon arrival.



Possible damage to tray components — If the outdoor temperature is below 0°C (32°F) when you receive your cabinet and trays, do not immediately unpack them or uncrate them. Exposing cold components to warm indoor temperatures can cause condensation, which results in component damage or failures.

Step 3: Remove packing materials

Remove the packing materials only after the cabinet has acclimated to the indoor temperature.

Steps

1. Refer to the unpacking instructions included on the front of the shipping crate.
2. Remove the packing materials according to the enclosed instructions.

Step 4: Check shipping contents

Check the shipping contents to make sure that all equipment arrived at the site.

Steps

1. Compare the packing list with the equipment that you received.
2. Make sure that all equipment arrived at the site.
3. If any items are missing, contact your sales representative.

Step 5: Remove heavy components from cabinet

Remove some of the heavier components that are located in the top of the cabinet to ensure maximum stability.

Before you begin

- Make sure the maximum weight does not exceed 2000 lbs before you move the cabinet.
- Note the location of each tray, component, and cable before removing it, so that you can reinstall each item in its original location.

Steps

1. Record the cable configuration for future reassembly if any cables must be disconnected.
2. Remove the drive trays and controller-drive trays in the top half of the cabinet. Keep all of the components from the same tray together.



You do not need to remove the power supplies or other components from the rear of each tray.

3. Place each component in a separate antistatic bag. If the original shipping boxes are available, use them to transport the components.

Move cabinet to its permanent location

The 3040 40U cabinet has heavy-duty casters that enable you to move the cabinet to its permanent location.

Before you begin

- Review the instructions for rolling the cabinet off the pallet without the use of a forklift.

Shipping crates provide built-in ramps and instructions. Refer to the unpacking instructions included on the front of the shipping crate.

- Evaluate all of the ramps between the loading dock and the cabinet's final destination.

You must evaluate all ramps to make sure that the cabinet's center of gravity (when the cabinet is on a ramp and sitting at an angle) does not extend beyond the cabinet's footprint.

About this task

Many of the cabinets are populated with drive trays. This situation results in most of the weight in the front portion of the cabinet, making the center of gravity closer to the front.

Steps

1. Remove the top-most devices in your cabinet to make sure that the cabinet is safely transported to its final location. This is especially important if any ramp has an incline or a decline greater than 10 degrees.
2. Move the cabinet to its permanent location using the correct method shown in the following figure. Make

sure that you push on the front of the cabinet, not the rear.

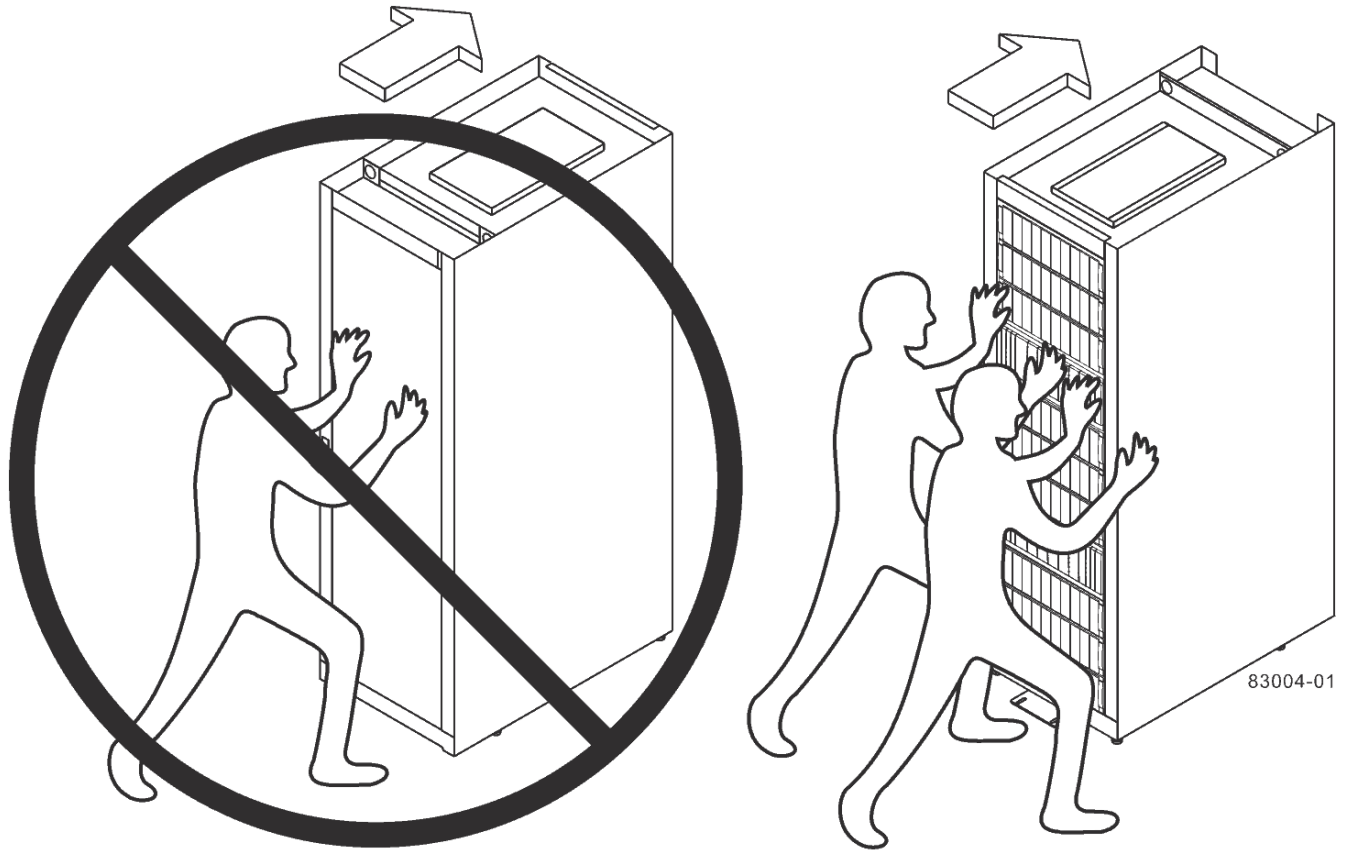

Rear of Cabinet

Front of Cabinet

Complete cabinet installation

After you move the cabinet, lower the leveling feet and the stability foot, reinstall the components you removed, install other required components, and connect the cabinet to power.

Step 1: Lower leveling feet and stability foot

You stabilize the cabinet by adjusting its feet. The leveling feet support the cabinet off the casters. The stability foot prevents the cabinet from falling over after it is placed in its permanent location.

Steps

1. Lower the leveling feet to support the cabinet off the casters.

The leveling feet are located near each bottom corner of the cabinet.

2. Make sure that the cabinet is as level as possible.

The following figure provides a close-up view of the stability foot and the leveling feet.

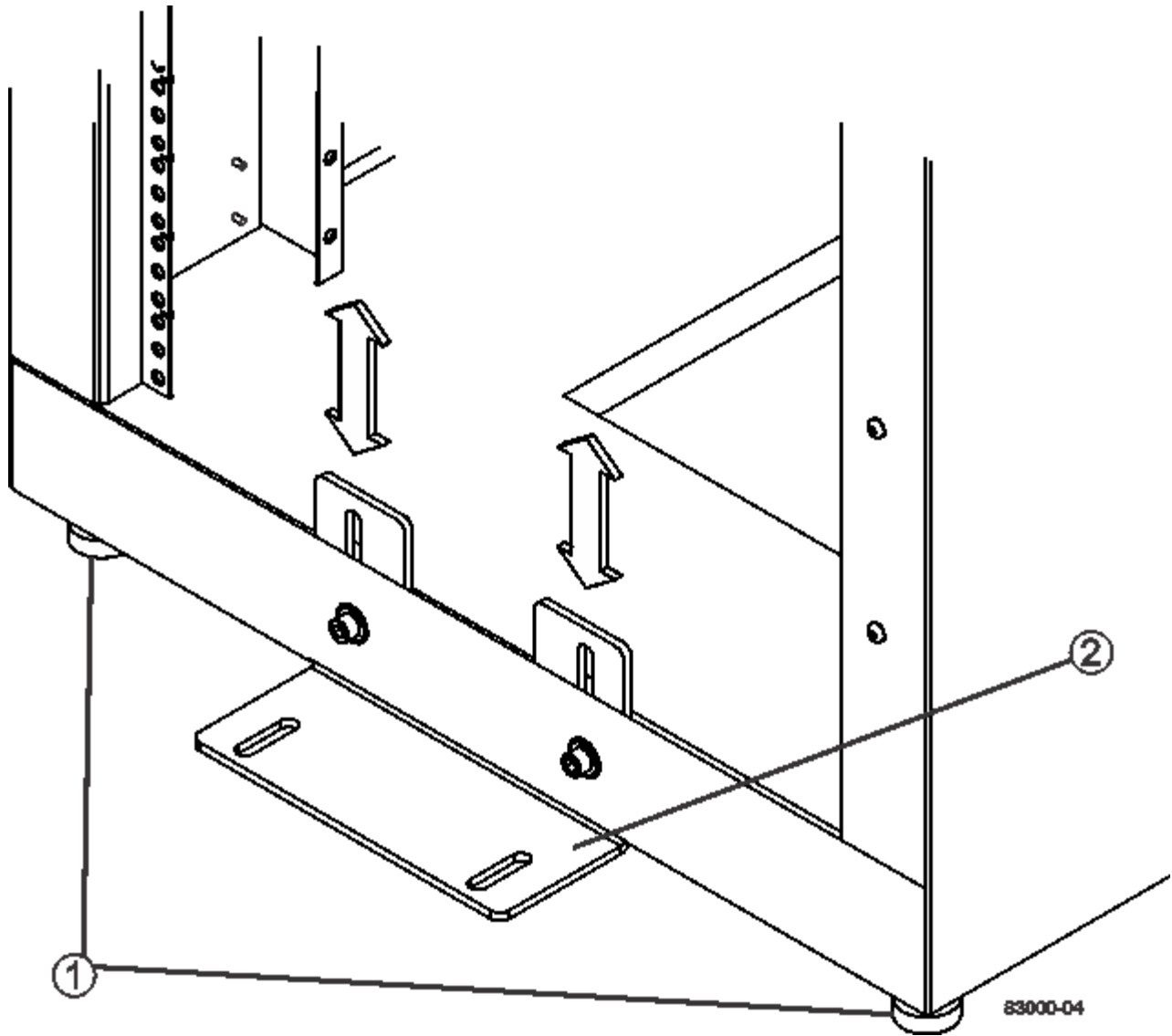

1.	Leveling feet
2.	Stability foot

Step 2: Reinstall trays

After you move the cabinet, you can reinstall the trays in their original locations.



Do not install the following trays in the top of the cabinet over your head. When fully-populated, each of these trays weighs over 100 kg (220 lb). If installed in the top of the cabinet, these trays create a top-heavy cabinet that can become easily unbalanced: E2660, E2660, E2760, E5460, E5560, and E5660 controller-drive trays, as well as the DE6600 drive tray.

Steps

1. Reinstall all of the trays in their original locations in the cabinet.



Risk of bodily injury — An empty tray weighs approximately 56.7 kg (125 lb). Three persons are required to safely move an empty tray. If the tray is populated with components, a mechanized lift is required to safely move the tray.

2. Reinstall all of the components in their original locations in the trays.

To prevent address conflicts and loss of data access, replace all components in the same tray and in the same location in the tray.

3. Reinstall all cables to their original locations in the trays.
4. Route the interface cables to the cabinet.
5. Route the main power cords from the cabinet to the two external power sources. *Do not* plug in the power cords at this time.

Step 3: Install cable spools and tie wraps

After you reinstall the trays, install the cable spools and tie wraps. The cable spools and tie wraps accommodate excess cable length and cable routing for the controllers and the trays.

Step

1. Install the cable spools and the tie wraps along both sides of the vertical power distribution outlets.

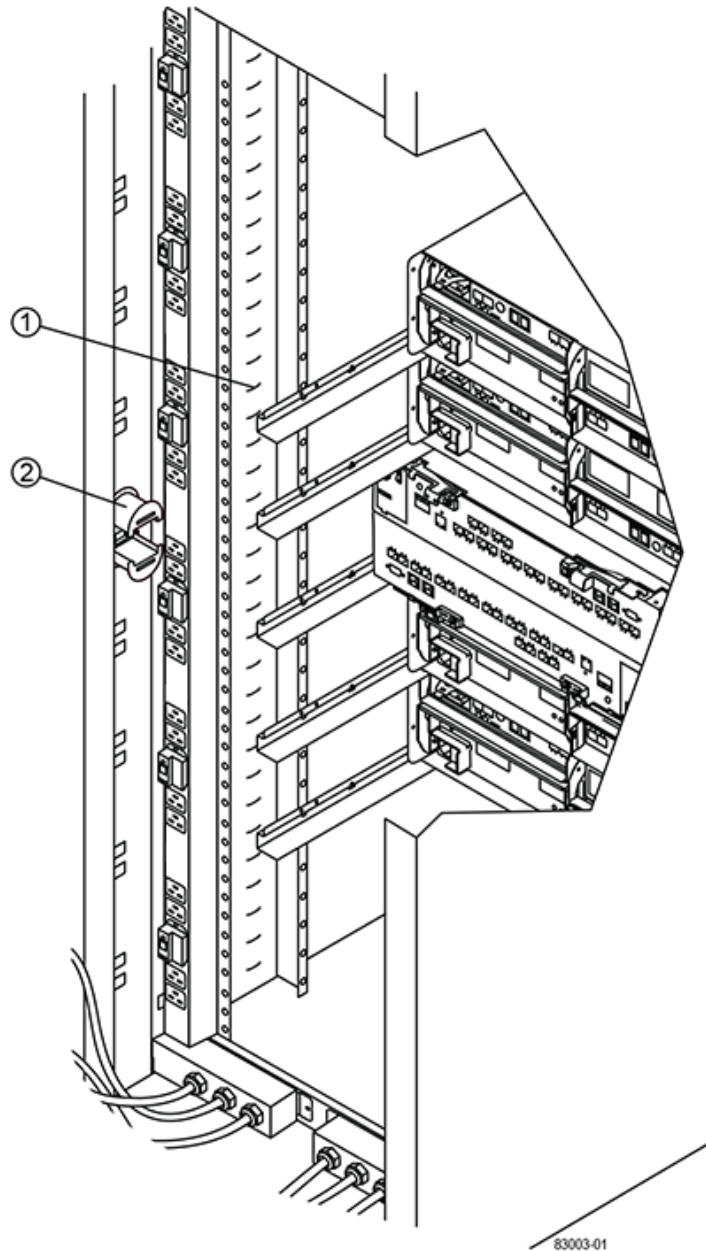

1.	Tie wrap location
2.	Cable spool

Step 4: Install additional trays

If needed, you can install additional trays. You must cover unused positions for trays to assure correct air flow.

Steps

1. If you have additional trays that must be installed, install the mounting hardware for these trays.
2. If the front of the cabinet is not completely filled with trays, use front panel kits to cover the empty spaces above or below the installed trays.

Covering the empty spaces is necessary so that the correct airflow through the cabinet is maintained.

3. Power on the trays.

Step 5: Install additional mounting rails

If you are installing controller-drive trays, or drive trays that were shipped separately (not already installed in the cabinet), you might need to install additional mounting rails in the cabinet.

Steps

1. Determine the location for the mounting rails.
 - **Above an existing tray** — Position the mounting rails immediately above the top tray in the cabinet.
 - **Beneath an existing tray** — Position the mounting rails with enough clearance to hold the tray being installed:
 - 8.9 cm (3.5 in.) for 2U controller-drive trays or drive trays
 - 17.8 cm (7 in.) for 4U controller-drive trays or drive trays
2. Use the measurement markers on the right-front and left-front vertical supports to attach the mounting rails to the same position on each side of the cabinet.

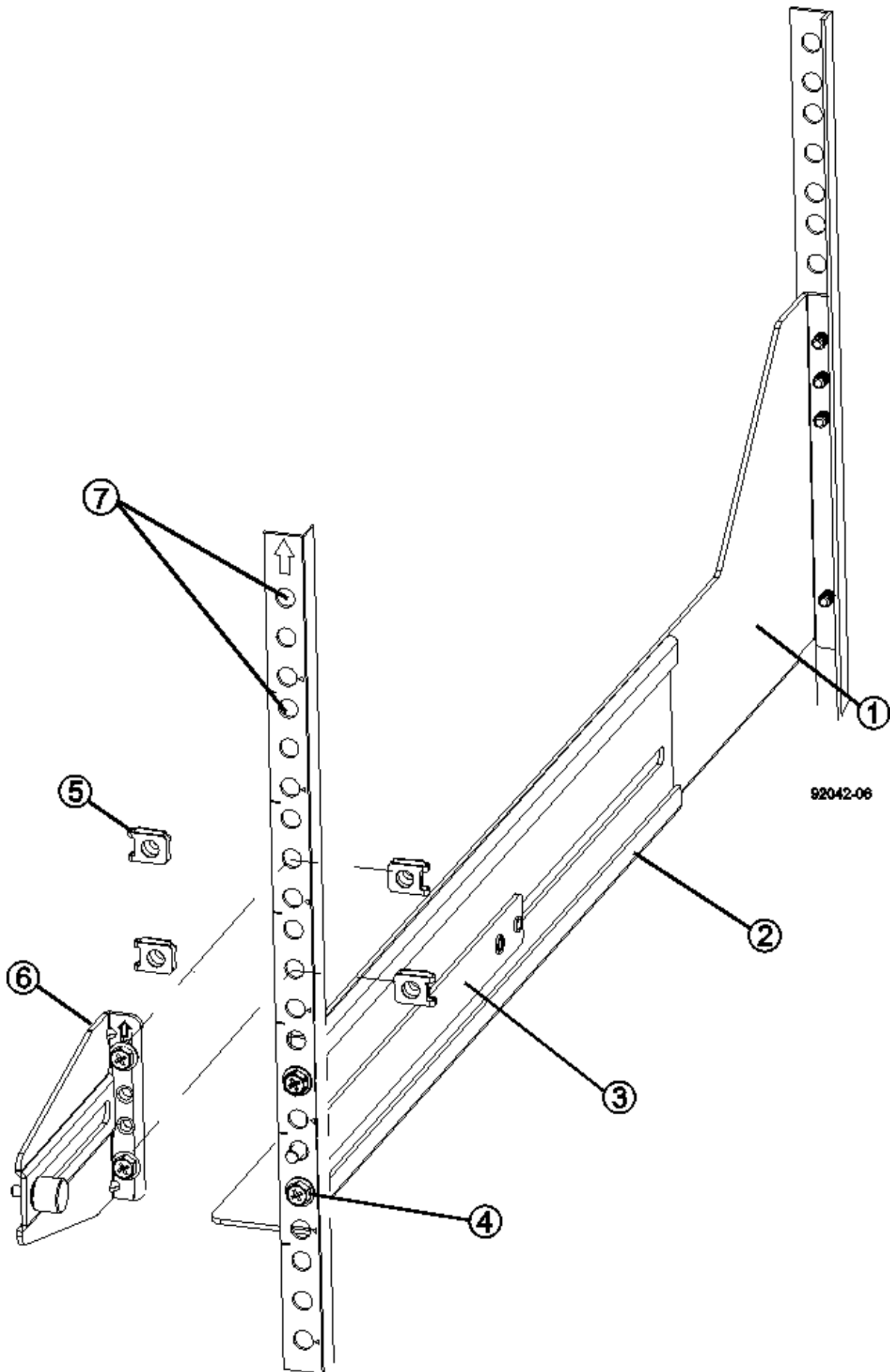

1.	Front adjustable rail
2.	Rear adjustable rail
3.	Adjustment plate and screws
4.	Rail mounting M5×10mm screws
5.	Clip nuts
6.	Rear hold down bracket
7.	Vertical support



The clip nuts and the rear hold down bracket are not used when the rails are installed in a 3040 cabinet.

3. Place the rear adjustable rail on the vertical support.
4. On the rear adjustable rail, align the adjustable rail holes in front of the holes in the vertical support.
5. Attach two M5×10mm screws.
 - a. Attach the screws through the vertical support rail and the rear adjustable rail.
 - b. Tighten the screws.
6. Place the front adjustable rail on the vertical support.
7. On the front adjustable rail, align the adjustable rail holes in front of the holes in the vertical support.
8. Attach two M5×10mm screws.
 - a. Attach one screw through the vertical support rail and the bottom hole of the front adjustable rail.
 - b. Attach one screw through the vertical support rail and the middle of the top three holes in the front adjustable rail.
 - c. Tighten the screws.



The remaining two screw holes are used to mount the tray.

9. Repeat step 3 through step 8 to attach the second rail on the other side of the cabinet.
10. Install each tray using the applicable tray installation instructions.
11. Choose one of the following options:
 - If all positions for trays are full, power-on the trays.
 - If not all positions for trays are full, use front panel kits to cover the empty spaces above or below the installed trays.

Step 6: Connect the cabinet to power

To complete the cabinet installation, power on the cabinet components.

About this task

While the trays perform the power-on procedure, the LEDs on the front and the rear of the trays blink. Depending on your configuration, it can take several minutes to complete the power-on procedure.

Steps

1. Turn off the power to all components in the cabinet.
2. Turn all 12 circuit breakers to their off (down) position.
3. Plug each of the six NEMA L6-30 connectors (USA and Canada) or the six IEC 60309 connectors (worldwide, except for USA and Canada) into an available electrical outlet.



You must connect each PDU to an independent power source outside of the cabinet.

4. Turn all 12 circuit breakers to their on (up) position.

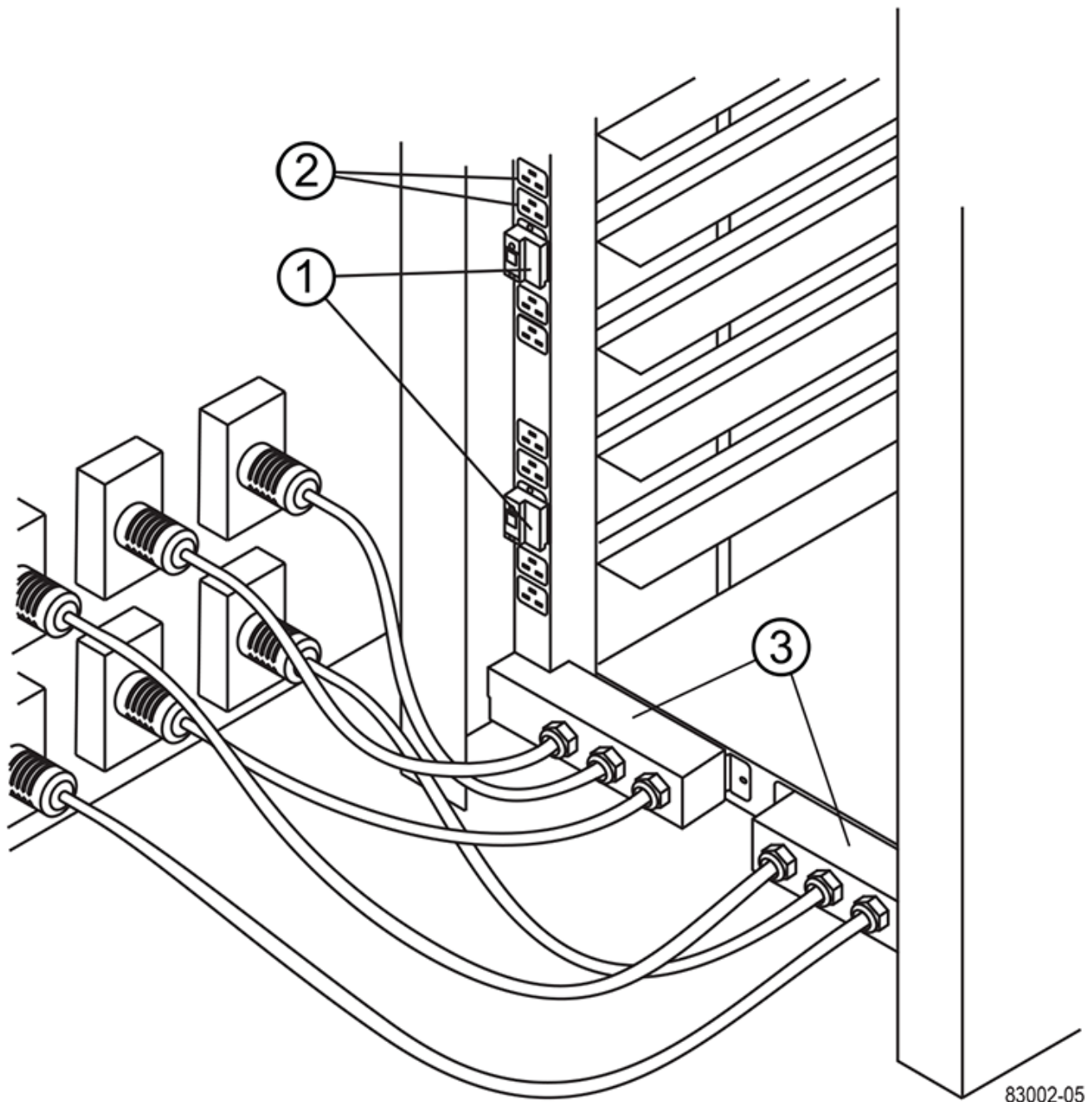

83002-05

1.	Circuit breakers
2.	Electrical outlets
3.	Power entry boxes

5. Turn on the power to all drive trays in the cabinet.



Wait 30 seconds after turning on the drive trays before you turn on the power to the controller-drive trays.

6. Wait 30 seconds after turning on the drive trays, and then turn on the power to all controller-drive trays in the cabinet.

Result

The cabinet installation is complete. You can resume normal operations.

Copyright Information

Copyright © 2022 NetApp, Inc. All rights reserved. Printed in the U.S. No part of this document covered by copyright may be reproduced in any form or by any means-graphic, electronic, or mechanical, including photocopying, recording, taping, or storage in an electronic retrieval system- without prior written permission of the copyright owner.

Software derived from copyrighted NetApp material is subject to the following license and disclaimer:

THIS SOFTWARE IS PROVIDED BY NETAPP "AS IS" AND WITHOUT ANY EXPRESS OR IMPLIED WARRANTIES, INCLUDING, BUT NOT LIMITED TO, THE IMPLIED WARRANTIES OF MERCHANTABILITY AND FITNESS FOR A PARTICULAR PURPOSE, WHICH ARE HEREBY DISCLAIMED. IN NO EVENT SHALL NETAPP BE LIABLE FOR ANY DIRECT, INDIRECT, INCIDENTAL, SPECIAL, EXEMPLARY, OR CONSEQUENTIAL DAMAGES (INCLUDING, BUT NOT LIMITED TO, PROCUREMENT OF SUBSTITUTE GOODS OR SERVICES; LOSS OF USE, DATA, OR PROFITS; OR BUSINESS INTERRUPTION) HOWEVER CAUSED AND ON ANY THEORY OF LIABILITY, WHETHER IN CONTRACT, STRICT LIABILITY, OR TORT (INCLUDING NEGLIGENCE OR OTHERWISE) ARISING IN ANY WAY OUT OF THE USE OF THIS SOFTWARE, EVEN IF ADVISED OF THE POSSIBILITY OF SUCH DAMAGE.

NetApp reserves the right to change any products described herein at any time, and without notice. NetApp assumes no responsibility or liability arising from the use of products described herein, except as expressly agreed to in writing by NetApp. The use or purchase of this product does not convey a license under any patent rights, trademark rights, or any other intellectual property rights of NetApp.

The product described in this manual may be protected by one or more U.S. patents, foreign patents, or pending applications.

RESTRICTED RIGHTS LEGEND: Use, duplication, or disclosure by the government is subject to restrictions as set forth in subparagraph (c)(1)(ii) of the Rights in Technical Data and Computer Software clause at DFARS 252.277-7103 (October 1988) and FAR 52-227-19 (June 1987).

Trademark Information

NETAPP, the NETAPP logo, and the marks listed at <http://www.netapp.com/TM> are trademarks of NetApp, Inc. Other company and product names may be trademarks of their respective owners.