



Drives

E-Series Systems

NetApp
January 29, 2025

Table of Contents

- Drives 1
 - Replace E4000 drive overview 1
 - Replace drive 2
 - Replace drive drawer in E4000 (60-drive shelf) 7
 - Hot adding a drive shelf 26

Drives

Replace E4000 drive overview

Before you replace an E4000 drive, review the requirements and considerations.

Shelf types

You can replace a drive in either a 12-drive, 24-drive, or 60-drive controller shelf or drive shelf.



Standard 24-drive shelves require drive staggering. When inserting fewer than 24 drives into an E4000 controller, you must alternate between the two halves of the controller. Beginning with the far left and then moving to the far right, place the drives in one at a time.

Drive handling

The drives in your storage array are fragile. Improper drive handling is a leading cause of drive failure.

Follow these rules to avoid damaging the drives in your storage array:

- Prevent electrostatic discharge (ESD):
 - Keep the drive in the ESD bag until you are ready to install it.
 - Do not insert a metal tool or knife into the ESD bag.

Open the ESD bag by hand or cut the top off with a pair of scissors.

- Keep the ESD bag and any packing materials in case you must return a drive later.
- Always wear an ESD wrist strap grounded to an unpainted surface on your storage enclosure chassis.

If a wrist strap is unavailable, touch an unpainted surface on your storage enclosure chassis before handling the drive.

- Handle drives carefully:
 - Always use two hands when removing, installing, or carrying a drive.
 - Never force a drive into a shelf, and use gentle, firm pressure to completely engage the drive latch.
 - Place drives on cushioned surfaces, and never stack drives on top of each other.
 - Do not bump drives against other surfaces.
 - Before removing a drive from a shelf, unlatch the handle and wait 60 seconds for the drive to spin down.
 - Always use approved packaging when shipping drives.
- Avoid magnetic fields:
 - Keep drives away from magnetic devices.

Magnetic fields can destroy all data on the drive and cause irreparable damage to the drive circuitry.

Replace drive

Replace drive in E4000 (12-drive or 24-drive shelf)

You can replace a drive in an E4000 with a 12-drive or 24-drive shelf.

About this task

The Recovery Guru in SANtricity System Manager monitors the drives in the storage array and can notify you of an impending drive failure or an actual drive failure. When a drive has failed, its amber Attention LED is on. You can hot-swap a failed drive while the storage array is receiving I/O.

Before you begin

- Review the drive handling requirements
- Make sure you have the following:
 - A replacement drive that is supported by NetApp for your controller shelf or drive shelf.
 - An ESD wristband, or you have taken other antistatic precautions.
 - A management station with a browser that can access SANtricity System Manager for the controller. (To open the System Manager interface, point the browser to the controller's domain name or IP address.)

Step 1: Prepare to replace drive

Prepare to replace a drive by checking the Recovery Guru in SANtricity System Manager and completing any prerequisite steps. Then, you can locate the failed component.

Steps

1. If the Recovery Guru in SANtricity System Manager has notified you of an *impending drive failure*, but the drive has not yet failed, follow the instructions in the Recovery Guru to fail the drive.
2. If needed, use SANtricity System Manager to confirm you have a suitable replacement drive.
 - a. Select **Hardware**.
 - b. Select the failed drive on the shelf graphic.
 - c. Click the drive to display its context menu, and then select **View settings**.
 - d. Confirm that the replacement drive has a capacity equal to or greater than the drive you are replacing and that it has the features you expect.
3. If needed, use SANtricity System Manager to locate the drive within your storage array. From the drive's context menu on the Hardware page, select **Turn on locator light**.

The drive's Attention LED (amber) blinks so you can identify which drive to replace.



If you are replacing a drive in a shelf that has a bezel, you must remove the bezel to see the drive LEDs.

Step 2: Remove failed drive

Remove a failed drive to replace it with a new one.

Steps

1. Unpack the replacement drive, and set it on a flat, static-free surface near the shelf.

Save all packing materials.

2. Press the release button on the failed drive.
3. Open the cam handle, and slide out the drive slightly.
4. Wait 60 seconds.
5. Using both hands, remove the drive from the shelf.
6. Place the drive on an antistatic, cushioned surface away from magnetic fields.
7. Wait 30 seconds for the software to recognize that the drive has been removed before moving on to "Step 3: Install new drive."



If you accidentally remove an active drive, wait at least 60 seconds, and then reinstall it. For the recovery procedure, refer to the storage management software.

Step 3: Install new drive

Install a new drive to replace the failed one.



Install the replacement drive as soon as possible after removing the failed drive. Otherwise, there is a risk that the equipment might overheat.

Steps

1. Open the cam handle.
2. Using two hands, insert the replacement drive into the open bay, firmly pushing until the drive stops.
3. Slowly close the cam handle until the drive is fully seated in the midplane and the handle clicks into place.

The green LED on the drive comes on when the drive is inserted correctly.



Depending on your configuration, the controller might automatically reconstruct data to the new drive. If the shelf uses hot spare drives, the controller might need to perform a complete reconstruction on the hot spare before it can copy the data to the replaced drive. This reconstruction process increases the time that is required to complete this procedure.

Step 4: Complete drive replacement

Complete the drive replacement to confirm that the new drive is working correctly.

Steps

1. Check the Power LED and the Attention LED on the drive you replaced. (When you first insert a drive, its Attention LED might be on. However, the LED should go off within a minute.)
 - Power LED is on or blinking, and the Attention LED is off: Indicates that the new drive is working correctly.
 - Power LED is off: Indicates that the drive might not be installed correctly. Remove the drive, wait 60 seconds, and then reinstall it.
 - Attention LED is on: Indicates that the new drive might be defective. Replace it with another new drive.

2. If the Recovery Guru in SANtricity System Manager still shows an issue, select **Recheck** to ensure the problem has been resolved.
3. If the Recovery Guru indicates that drive reconstruction did not start automatically, start reconstruction manually, as follows:



Perform this operation only when instructed to do so by technical support or the Recovery Guru.

- a. Select **Hardware**.
- b. Click the drive that you replaced.
- c. From the drive's context menu, select **Reconstruct**.
- d. Confirm that you want to perform this operation.

When the drive reconstruction completes, the volume group is in an Optimal state.

4. As required, reinstall the bezel.
5. Return the failed part to NetApp, as described in the RMA instructions shipped with the kit.

What's next?

Your drive replacement is complete. You can resume normal operations.

Replace drive in E4000 (60-drive shelf)

You can replace a drive in an E4000 with a 60-drive shelf.

About this task

The Recovery Guru in SANtricity System Manager monitors the drives in the storage array and can notify you of an impending drive failure or an actual drive failure. When a drive has failed, its amber Attention LED is on. You can hot-swap a failed drive while the storage array is receiving I/O operations.

This procedure applies to DCM and DCM2 drive shelves.

Before you begin

- Review the drive handling requirements.
- Make sure you have the following:
 - A replacement drive that is supported by NetApp for your controller shelf or drive shelf.
 - An ESD wristband, or you have taken other antistatic precautions.
 - A management station with a browser that can access SANtricity System Manager for the controller. (To open the System Manager interface, point the browser to the controller's domain name or IP address.)

Step 1: Prepare to replace drive

Prepare to replace a drive by checking the Recovery Guru in SANtricity System Manager and completing any prerequisite steps. Then, you can locate the failed component.

Steps

1. If the Recovery Guru in SANtricity System Manager has notified you of an *impending drive failure*, but the drive has not yet failed, follow the instructions in the Recovery Guru to fail the drive.

2. If needed, use SANtricity System Manager to confirm you have a suitable replacement drive.
 - a. Select **Hardware**.
 - b. Select the failed drive on the shelf graphic.
 - c. Click the drive to display its context menu, and then select **View settings**.
 - d. Confirm that the replacement drive has a capacity equal to or greater than the drive you are replacing and that it has the features you expect.
3. If needed, use SANtricity System Manager to locate the drive within the storage array.
 - a. If the shelf has a bezel, remove it so you can see the LEDs.
 - b. From the drive's context menu, select **Turn on locator light**.

The drive drawer's Attention LED (amber) blinks so you can open the correct drive drawer to identify which drive to replace.

4. Unlatch the drive drawer by pulling on both levers.
 - a. Using the extended levers, carefully pull the drive drawer out until it stops.
 - b. Look at the top of the drive drawer to find the Attention LED in front of each drive.

The drive drawer Attention LEDs are on the left side in front of each drive, with an attention icon on the drive handle just behind the LED.

Step 2: Remove failed drive

Remove a failed drive to replace it with a new one.

Steps

1. Unpack the replacement drive, and set it on a flat, static-free surface near the shelf.

Save all packing materials for the next time you need to send a drive back.
2. Release the drive drawer levers from the center of the appropriate drive drawer by pulling both towards the sides of the drawer.
3. Carefully pull on the extended drive drawer levers to pull out the drive drawer to its full extension without removing it from the enclosure.
4. Gently pull back the orange release latch that is in front of the drive you want to remove.

The cam handle on the drive springs open partially, and the drive is released from the drawer.

5. Open the cam handle, and lift out the drive slightly.
6. Wait 60 seconds.
7. Use the cam handle to lift the drive from the shelf.
8. Place the drive on an antistatic, cushioned surface away from magnetic fields.
9. Wait 30 seconds for the software to recognize that the drive has been removed before moving on to "Step 3: Install new drive."



If you accidentally remove an active drive, wait at least 60 seconds, and then reinstall it. For the recovery procedure, refer to the storage management software.

Step 3: Install new drive

Install a new drive to replace the failed one.



Install the replacement drive as soon as possible after removing the failed drive. Otherwise, there is a risk that the equipment might overheat.



Possible loss of data access — When pushing the drive drawer back into the enclosure, never slam the drawer shut. Push the drawer in slowly to avoid jarring the drawer and causing damage to the storage array.

Steps

1. Raise the cam handle on the new drive to vertical.
2. Align the two raised buttons on each side of the drive carrier with the matching gap in the drive channel on the drive drawer.
3. Lower the drive straight down, and then rotate the cam handle down until the drive snaps into place under the orange release latch.
4. Carefully push the drive drawer back into the enclosure. Push the drawer in slowly to avoid jarring the drawer and causing damage to the storage array.
5. Close the drive drawer by pushing both levers towards the center.

The green Activity LED for the replaced drive on the front of the drive drawer comes on when the drive is inserted correctly.

Depending on your configuration, the controller might automatically reconstruct data to the new drive. If the shelf uses hot spare drives, the controller might need to perform a complete reconstruction on the hot spare before it can copy the data to the replaced drive. This reconstruction process increases the time that is required to complete this procedure.

Step 4: Complete drive replacement

Confirm that the new drive is working correctly.

Steps

1. Check the Power LED and the Attention LED on the drive you replaced. (When you first insert a drive, its Attention LED might be on. However, the LED should go off within a minute.)
 - Power LED is on or blinking, and the Attention LED is off: Indicates that the new drive is working correctly.
 - Power LED is off: Indicates that the drive might not be installed correctly. Remove the drive, wait 60 seconds, and then reinstall it.
 - Attention LED is on: Indicates that the new drive might be defective. Replace it with another new drive.
2. If the Recovery Guru in SANtricity System Manager still shows an issue, select **Recheck** to ensure the problem has been resolved.
3. If the Recovery Guru indicates that drive reconstruction did not start automatically, start reconstruction manually, as follows:



Perform this operation only when instructed to do so by technical support or the Recovery Guru.

- a. Select **Hardware**.
- b. Click the drive that you replaced.
- c. From the drive's context menu, select **Reconstruct**.
- d. Confirm that you want to perform this operation.

When the drive reconstruction completes, the volume group is in an Optimal state.

4. As required, reinstall the bezel.
5. Return the failed part to NetApp, as described in the RMA instructions shipped with the kit.

What's next?

Your drive replacement is complete. You can resume normal operations.

Replace drive drawer in E4000 (60-drive shelf)

You can replace a drive drawer in an E4060 controller shelf or a DE460C drive shelf.

About this task

The steps to replace a failed drive drawer in an E4060 controller shelf or a DE460C drive shelf depend on whether the volumes in the drawer are protected by Drawer Loss Protection. If all volumes in the drive drawer are in disk pools or volume groups that have Drawer Loss Protection, you can perform this procedure online. Otherwise, you must stop all host I/O activity and power off the shelf before replacing the drive drawer.

Before you begin

- Make sure the drive shelf meets all of these conditions:
 - The drive shelf cannot be over temperature.
 - Both fans must be installed and have a status of Optimal.
 - All drive shelf components must be in place.
 - The volumes in the drive drawer cannot be in a Degraded state.



Possible loss of data access — If a volume is already in a Degraded state, and you remove drives from the drive drawer, the volume can fail.

- Make sure you have the following:
 - A replacement drive drawer.
 - An ESD wristband, or you have taken other antistatic precautions.
 - A flashlight.
 - A permanent marker to note the exact location of each drive as you remove the drive from the drawer.
 - Access to the storage array's command line interface (CLI). If you do not have access to the CLI, you can do one of the following:
 - **For SANtricity System Manager (version 11.60 and above)** — Download the CLI package (zip file) from System Manager. Go to **Settings > System > Add-ons > Command Line Interface**. You can then issue CLI commands from an operating system prompt, such as the DOS C: prompt.
 - **For SANtricity Storage Manager/Enterprise Management Window (EMW)** — Follow the instructions in the express guide to download and install the software. You can run CLI commands

from the EMW by selecting **Tools > Execute Script**.



If you need information on how to replace an E-Series DE460c expansion shelf, please refer to the [NetApp Knowledge base](#).

Step 1: Prepare to replace drive drawer

Determine if you can perform the replacement procedure while the drive shelf is online or if you need to stop host I/O activity and power off any of the shelves that are powered on.

If you are replacing a drawer in a shelf with Drawer Loss Protection, there is no need to stop host I/O activity and power off any of the shelves.

Steps

1. Determine if the drive shelf is powered on.
 - If the power is off, you do not need to issue the CLI command. Go to [Step 2: Remove cable chains](#).
 - If the power is on, go to the next step.
2. Access the CLI, and then enter the following command:

```
SMcli <ctrl_IP1\> -p "array_password" -c "set tray [trayID] drawer  
[drawerID]  
serviceAllowedIndicator=on;"
```

where:

- <ctrl_IP1> is the identifier of the controller.
- array_password is the password for the storage array. You must enclose the value for array_password in double quotation marks ("").
- [trayID] is the identifier of the drive shelf that contains the drive drawer that you want to replace. Drive shelf ID values are 0 to 99. You must enclose the value for trayID in square brackets.
- [drawerID] is the identifier of the drive drawer that you want to replace. Drawer ID values are 1 (top drawer) to 5 (bottom drawer). You must enclose the value for drawerID in square brackets.

This command ensures you can remove the top-most drawer in drive shelf 10:

```
SMcli <ctrl_IP1\> -p "safety-1" -c "set tray [10] drawer [1]  
serviceAllowedIndicator=forceOnWarning;"
```

3. Determine if you need to stop host I/O activity, as follows:
 - If the command succeeds, you do not need to stop host I/O activity. All drives in the drawer are in pools or volume groups with Drawer Loss Protection. Go to [Step 2: Remove cable chains](#).



Possible damage to drives — Wait 60 seconds after the command completes before you open the drive drawer. Waiting 60 seconds allows the drives to spin down, which prevents possible damage to the hardware.

- If a warning is displayed indicating that this command could not be completed, you must stop host I/O activity before removing the drawer. The warning is displayed because one or more drives in the affected drawer are in pools or volume groups without Drawer Loss Protection. To avoid losing data, you must complete the next steps to stop host I/O activity and to power off the drive shelf and the controller shelf.
4. Ensure that no I/O operations are occurring between the storage array and all connected hosts. For example, you can perform these steps:
 - Stop all processes that involve the LUNs mapped from the storage to the hosts.
 - Ensure that no applications are writing data to any LUNs mapped from the storage to the hosts.
 - Unmount all file systems associated with volumes on the array.



The exact steps to stop host I/O operations depend on the host operating system and the configuration, which are beyond the scope of these instructions. If you are not sure how to stop host I/O operations in your environment, consider shutting down the host.

5. If the storage array participates in a mirroring relationship, stop all host I/O operations on the secondary storage array.



Possible data loss — If you continue this procedure while I/O operations are occurring, the host application might lose data because the storage array will not be accessible.

6. Wait for any data in cache memory to be written to the drives.

The green Cache Active LED on the back of each controller is on when cached data needs to be written to the drives. You must wait for this LED to turn off.

7. From the Home page of SANtricity System Manager, select **View Operations in Progress**.
8. Wait for all operations to complete before continuing with the next step.
9. Power off the shelves, using one of the following procedures:
 - *If you are replacing a drawer in a shelf **with** Drawer Loss Protection:* There is NO need to power off any of the shelves. You can perform the replace procedure while the drive drawer is online, because the Set Drawer Service Action Allowed Indicator CLI command completed successfully.
 - *If you are replacing a drawer in a **controller** shelf **without** Drawer Loss Protection:*
 - a. Turn off both power switches on the controller shelf.
 - b. Wait for all LEDs on the controller shelf to go dark.
 - *If you are replacing a drawer in an **expansion** drive shelf **without** Drawer Loss Protection:*
 - a. Turn off both power switches on the controller shelf.
 - b. Wait for all LEDs on the controller shelf to go dark.
 - c. Turn off both power switches on the drive shelf.
 - d. Wait two minutes for drive activity to stop.

Step 2: Remove cable chains

Remove both cable chains so you can remove and replace a failed drive drawer.

About this task

Each drive drawer has left and right cable chains. The left and right cable chains allow the drawers to slide in and out.

The metal ends on the cable chains slide into corresponding vertical and horizontal guide rails inside the enclosure, as follows:

- The left and right vertical guide rails connect the cable chain to the enclosure's midplane.
- The left and right horizontal guide rails connect the cable chain to the individual drawer.



Possible hardware damage — If the drive tray is powered on, the cable chain is energized until both ends are unplugged. To avoid shorting out the equipment, do not allow the unplugged cable chain connector to touch the metal chassis if the other end of the cable chain is still plugged in.

Steps

1. Make sure that the drive shelf and controller shelf no longer has I/O activity and is powered off, or you have issued the `Set Drawer Attention Indicator` CLI command.
2. From the rear of the drive shelf, remove the right fan canister:
 - a. Press the orange tab to release the fan canister handle.

The figure shows the handle for the fan canister extended and released from the orange tab on the left.

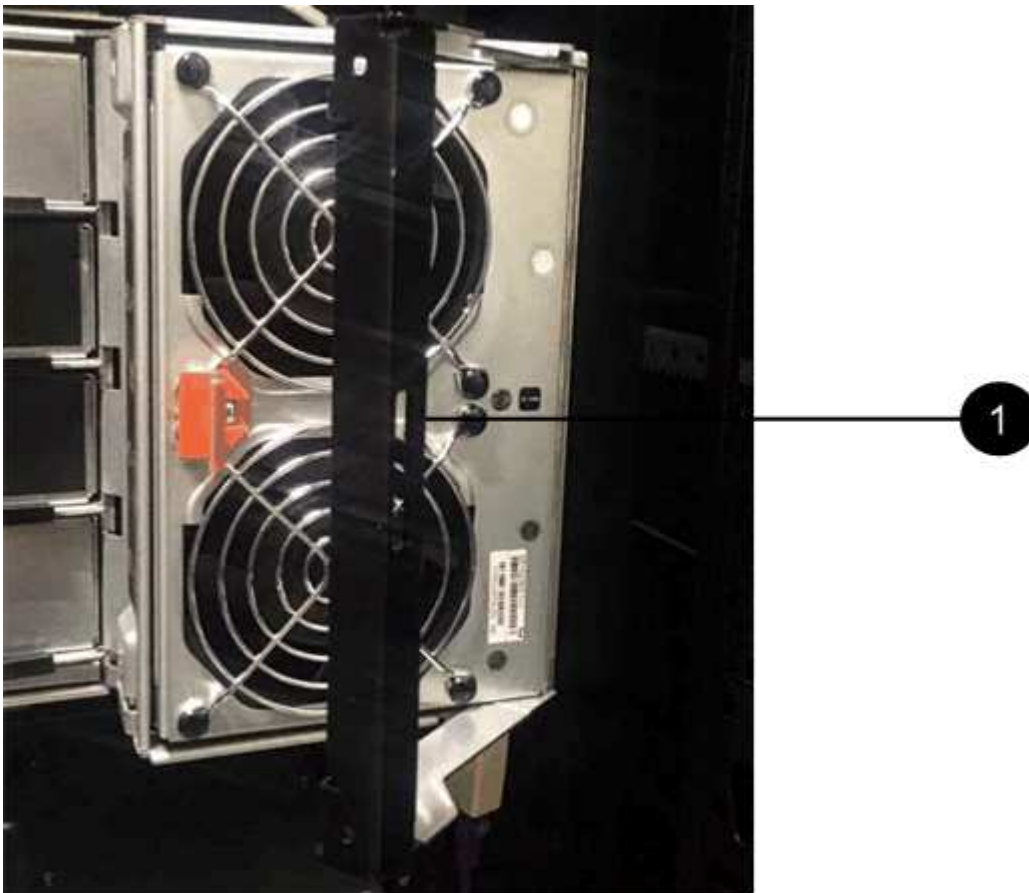

(1) *Fan canister handle*

- b. Using the handle, pull the fan canister out of the drive tray, and set it aside.
- c. If the tray is powered on, ensure that the left fan goes to its maximum speed.



Possible equipment damage due to overheating — If the tray is powered on, do not remove both fans at the same time. Otherwise, the equipment might overheat.

3. Determine which cable chain to disconnect:

- If the power is on, the amber Attention LED on the front of the drawer indicates the cable chain you need to disconnect.
- If the power is off, you must manually determine which of the five cable chains to disconnect. The figure shows the right side of the drive shelf with the fan canister removed. With the fan canister removed, you can see the five cable chains and the vertical and horizontal connectors for each drawer.

The top cable chain is attached to drive drawer 1. The bottom cable chain is attached to drive drawer 5. The callouts for drive drawer 1 are provided.



(1) Cable chain

(2) Vertical connector (connected to midplane)

(3) Horizontal connector (connected to drawer)

4. For easy access, use your finger to move the cable chain on the right side to the left.
5. Disconnect any of the right cable chains from their corresponding vertical guide rail.
 - a. Using a flashlight, locate the orange ring on the end of the cable chain that is connected to the vertical guide rail in the enclosure.



(1) Orange ring on vertical guide rail

(2) Cable chain, partially removed

- b. To unlatch the cable chain, insert your finger into the orange ring and press towards the middle of the system.

c. To unplug the cable chain, carefully pull your finger toward you approximately 1 inch (2.5 cm). Leave the cable chain connector within the vertical guide rail. (If the drive tray is powered on, do not allow the cable chain connector to touch the metal chassis.)

6. Disconnect the other end of the cable chain:

a. Using a flashlight, locate the orange ring on the end of the cable chain that is attached to the horizontal guide rail in the enclosure.

The figure shows the horizontal connector on the right and the cable chain disconnected and partially pulled out on the left side.

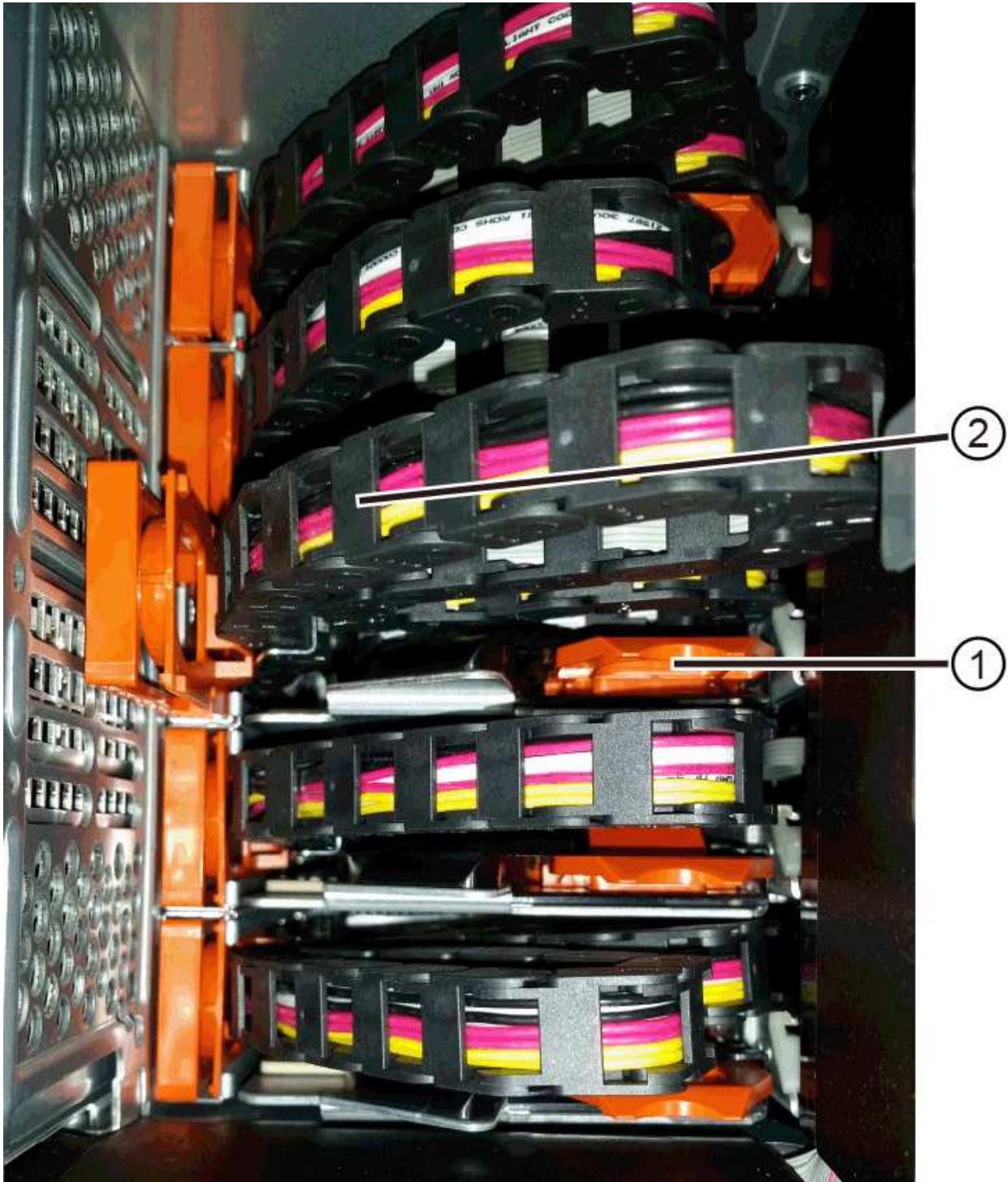

(1) *Orange ring on horizontal guide rail*

(2) *Cable chain, partially removed*

- b. To unlatch the cable chain, gently insert your finger into the orange ring and push down.

The figure shows the orange ring on the horizontal guide rail (see item 1 in the figure above), as it is pushed down so that the rest of the cable chain can be pulled out of the enclosure.

- c. Pull your finger toward you to unplug the cable chain.
7. Carefully pull the entire cable chain out of the drive shelf.
 8. Replace the right fan canister:
 - a. Slide the fan canister all the way into the shelf.
 - b. Move the fan canister handle until it latches with the orange tab.
 - c. If the drive shelf is receiving power, confirm that the amber Attention LED on the back of the fan is not illuminated and that air is coming out the back of the fan.

The LED could remain on for as long as a minute after you reinstall the fan while both fans settle into the correct speed.

If the power is off, the fans do not run and the LED is not on.

9. From the back of the drive shelf, remove the left fan canister.
10. If the drive shelf is receiving power, ensure that the right fan goes to its maximum speed.



Possible equipment damage due to overheating — If the shelf is powered on, do not remove both fans at the same time. Otherwise, the equipment might overheat.

11. Disconnect the left cable chain from its vertical guide rail:
 - a. Using a flashlight, locate the orange ring on the end of the cable chain attached to the vertical guide rail.
 - b. To unlatch the cable chain, insert your finger into the orange ring.
 - c. To unplug the cable chain, pull toward you approximately 1 inch (2.5 cm). Leave the cable chain connector within the vertical guide rail.



Possible hardware damage — If the drive tray is powered on, the cable chain is energized until both ends are unplugged. To avoid shorting out the equipment, do not allow the unplugged cable chain connector to touch the metal chassis if the other end of the cable chain is still plugged in.

12. Disconnect the left cable chain from the horizontal guide rail, and pull the entire cable chain out of the drive shelf.

If you are performing this procedure with the power on, all LEDs turn off when you disconnect the last cable chain connector, including the amber Attention LED.

13. Replace the left fan canister. If the drive shelf is receiving power, confirm that the amber LED on the back of the fan is not illuminated and that air is coming out the back of the fan.

The LED could remain on for as long as a minute after you reinstall the fan while both fans settle into the

correct speed.

Step 3: Remove failed drive drawer

Remove a failed drive drawer to replace it with a new one.



Possible loss of data access — Magnetic fields can destroy all data on the drive and cause irreparable damage to the drive circuitry. To avoid loss of data access and damage to the drives, always keep drives away from magnetic devices.

Steps

1. Make sure that:
 - The right and left cable chains are disconnected.
 - The right and left fan canisters are replaced.
2. Remove the bezel from the front of the drive shelf.
3. Unlatch the drive drawer by pulling out on both levers.
4. Using the extended levers, carefully pull the drive drawer out until it stops. Do not completely remove the drive drawer from the drive shelf.
5. If volumes have already been created and assigned, use a permanent marker to note the exact location of each drive. For example, using the following drawing as a reference, write the appropriate slot number on the top of each drive.

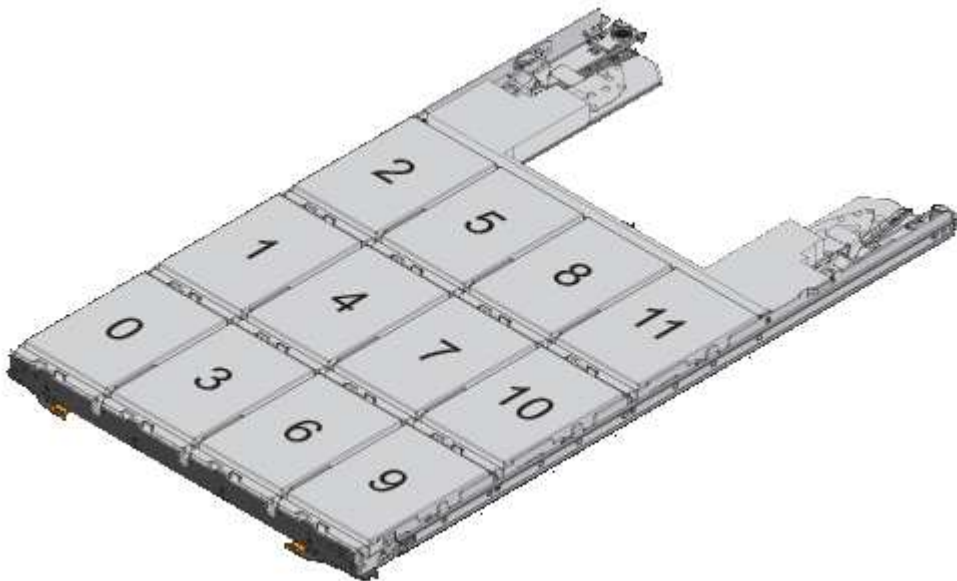

Possible loss of data access — Make sure to record the exact location of each drive before removing it.

6. Remove the drives from the drive drawer:
 - a. Gently pull back the orange release latch that is visible on the center front of each drive.
 - b. Raise the drive handle to vertical.
 - c. Use the handle to lift the drive from the drive drawer.

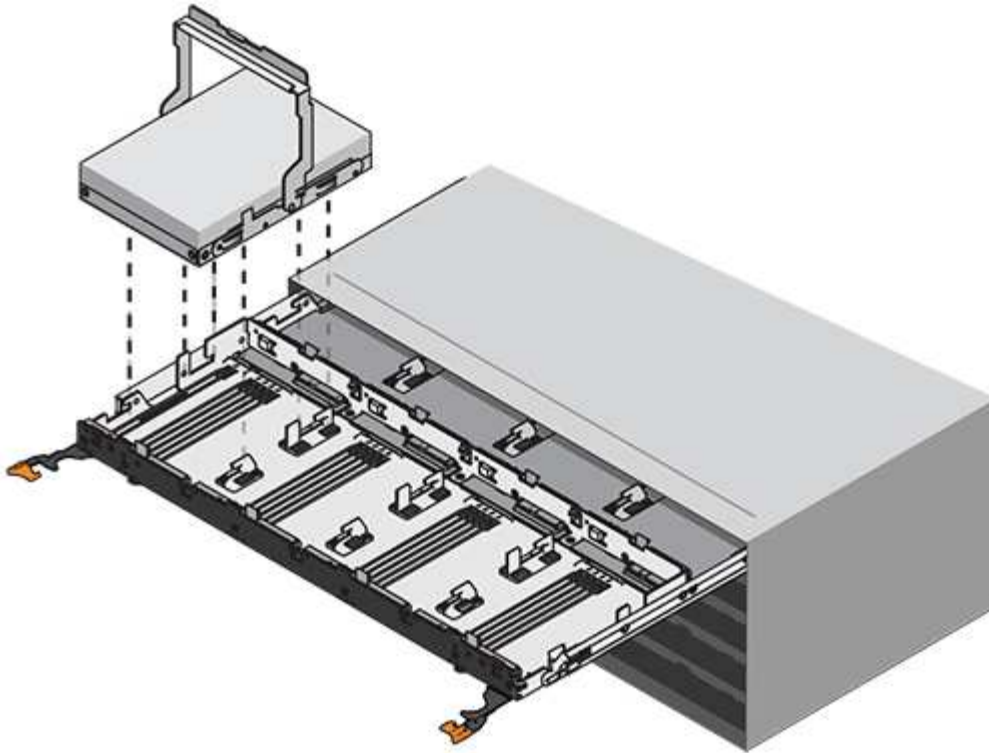

d. Place the drive on a flat, static-free surface and away from magnetic devices.

7. Remove the drive drawer:

a. Locate the plastic release lever on each side of the drive drawer.

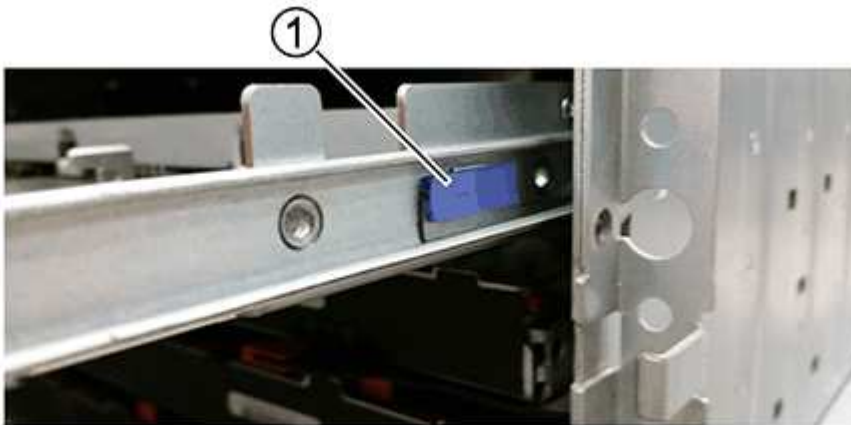

(1) *Drive drawer release lever*

b. Disengage both release levers by pulling the latches toward you.

c. While holding both release levers, pull the drive drawer toward you.

d. Remove the drive drawer from the drive shelf.

Step 4: Install new drive drawer

Install a new drive drawer to replace the failed one.

Steps

1. From the front of the drive shelf, shine a flashlight into the empty drawer slot, and locate the lock-out tumbler for that slot.

The lock-out tumbler assembly is a safety feature that prevents you from being able to open more than one drive drawer at one time.

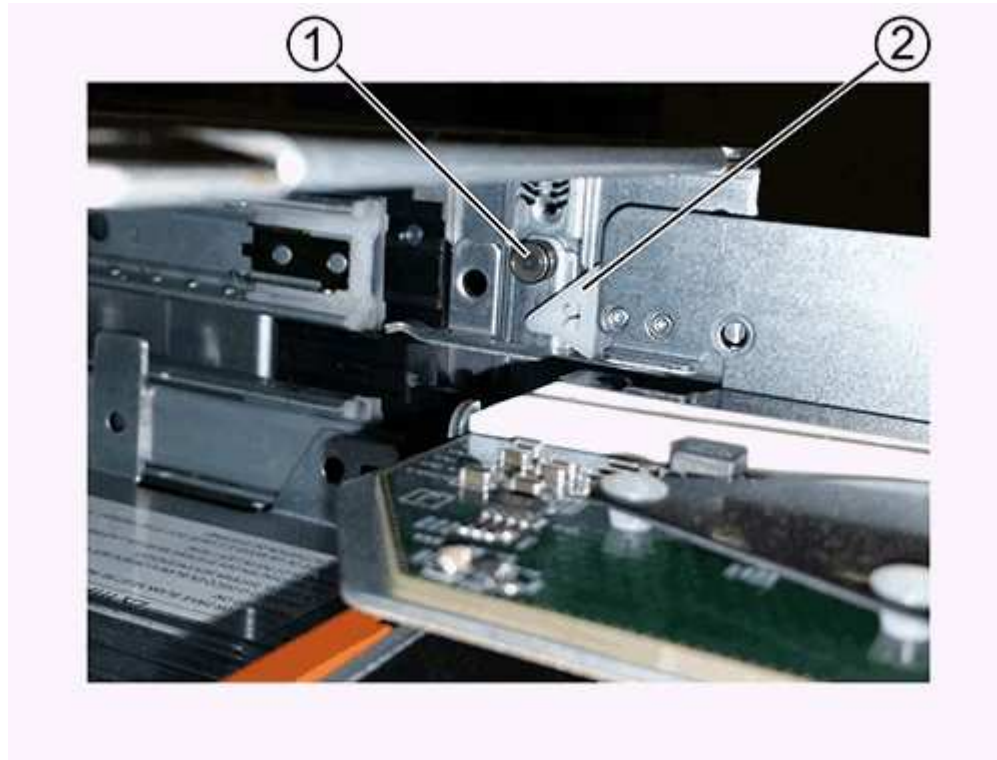

(1) *Lock-out tumbler*

(2) *Drawer guide*

2. Position the replacement drive drawer in front of the empty slot and slightly to the right of center.

Positioning the drawer slightly to the right of center helps to ensure that the lock-out tumbler and the drawer guide are correctly engaged.

3. Slide the drive drawer into the slot, and ensure that the drawer guide slides under the lock-out tumbler.



Risk of equipment damage — Damage occurs if the drawer guide does not slide under the lock-out tumbler.

4. Carefully push the drive drawer all the way in until the latch fully engages.

Experiencing a higher level of resistance is normal when pushing the drawer closed for the first time.



Risk of equipment damage — Stop pushing the drive drawer if you feel binding. Use the release levers at the front of the drawer to slide the drawer back out. Then, reinsert the drawer into the slot, ensure the tumbler is above the rail, and the rails are aligned correctly.

Step 5: Attach cable chains

Attach the cable chains so you can safely re-install the drives in the drive drawer.

About this task

When attaching a cable chain, reverse the order you used when disconnecting the cable chain. You must insert the chain's horizontal connector into the horizontal guide rail in the enclosure before inserting the chain's vertical connector into the vertical guide rail in the enclosure.

Steps

1. Make sure that:
 - A new drive drawer installed.
 - You have two replacement cable chains, marked as LEFT and RIGHT (on the horizontal connector next to the drive drawer).
2. From the back of the drive shelf, remove the fan canister on the right side, and set it aside.
3. If the shelf is powered on, ensure that the left fan goes to its maximum speed.



Possible equipment damage due to overheating — If the shelf is powered on, do not remove both fans at the same time. Otherwise, the equipment might overheat.

4. Attach the right cable chain:
 - a. Locate the horizontal and vertical connectors on the right cable chain and the corresponding horizontal guide rail and vertical guide rail inside the enclosure.
 - b. Align both cable chain connectors with their corresponding guide rails.
 - c. Slide the cable chain's horizontal connector onto the horizontal guide rail, and push it in as far as it can go.



Risk of equipment malfunction — Make sure to slide the connector into the guide rail. If the connector rests on the top of the guide rail, problems might occur when the system runs.

The figure shows the horizontal and vertical guide rails for the second drive drawer in the enclosure.



(1) *Horizontal guide rail*

(2) *Vertical guide rail*

- d. Slide the vertical connector on the right cable chain into the vertical guide rail.
- e. After you have reconnected both ends of the cable chain, carefully pull on the cable chain to verify that both connectors are latched.



Risk of equipment malfunction — If the connectors are not latched, the cable chain might come loose during drawer operation.

5. Reinstall the right fan canister. If the drive shelf is receiving power, confirm that the amber LED on the back of the fan is now off and that air is now coming out of the back.

The LED could remain on for as long as a minute after you reinstall the fan while the fan settles into the correct speed.

6. From the back of the drive shelf, remove the fan canister on the left side of the shelf.
7. If the shelf is powered on, ensure that the right fan goes to its maximum speed.



Possible equipment damage due to overheating — If the shelf is powered on, do not remove both fans at the same time. Otherwise, the equipment might overheat.

8. Reattach the left cable chain:
 - a. Locate the horizontal and vertical connectors on the cable chain and their corresponding horizontal and vertical guide rails inside the enclosure.
 - b. Align both cable chain connectors with their corresponding guide rails.
 - c. Slide the cable chain's horizontal connector into the horizontal guide rail and push it in as far as it will go.



Risk of equipment malfunction — Make sure to slide the connector within the guide rail. If the connector rests on the top of the guide rail, problems might occur when the system runs.

- d. Slide the vertical connector on the left cable chain into the vertical guide rail.
- e. After you reconnect both ends of the cable chain, carefully pull on the cable chain to verify that both connectors are latched.



Risk of equipment malfunction — If the connectors are not latched, the cable chain might come loose during drawer operation.

9. Reinstall the left fan canister. If the drive shelf is receiving power, confirm that the amber LED on the back of the fan is now off and that air is now coming out of the back.

The LED could remain on for as long as a minute after you reinstall the fan while both fans settle into the correct speed.

Step 6: Complete drive drawer replacement

Reinsert the drives and replace the front bezel in the correct order.



Possible loss of data access — You must install each drive in its original location in the drive drawer.

Steps

1. Make sure that:
 - You know where to install each drive.
 - You have replaced the drive drawer.
 - You have installed the new drawer cables.
2. Reinstall the drives in the drive drawer:
 - a. Unlatch the drive drawer by pulling out on both levers at the front of the drawer.
 - b. Using the extended levers, carefully pull the drive drawer out until it stops. Do not completely remove the drive drawer from the drive shelf.
 - c. Determine which drive to install in each slot by using the notes you made when removing the drives.



- d. Raise the handle on the drive to vertical.
- e. Align the two raised buttons on each side of the drive with the notches on the drawer.

The figure shows the right side view of a drive, showing the location of the raised buttons.

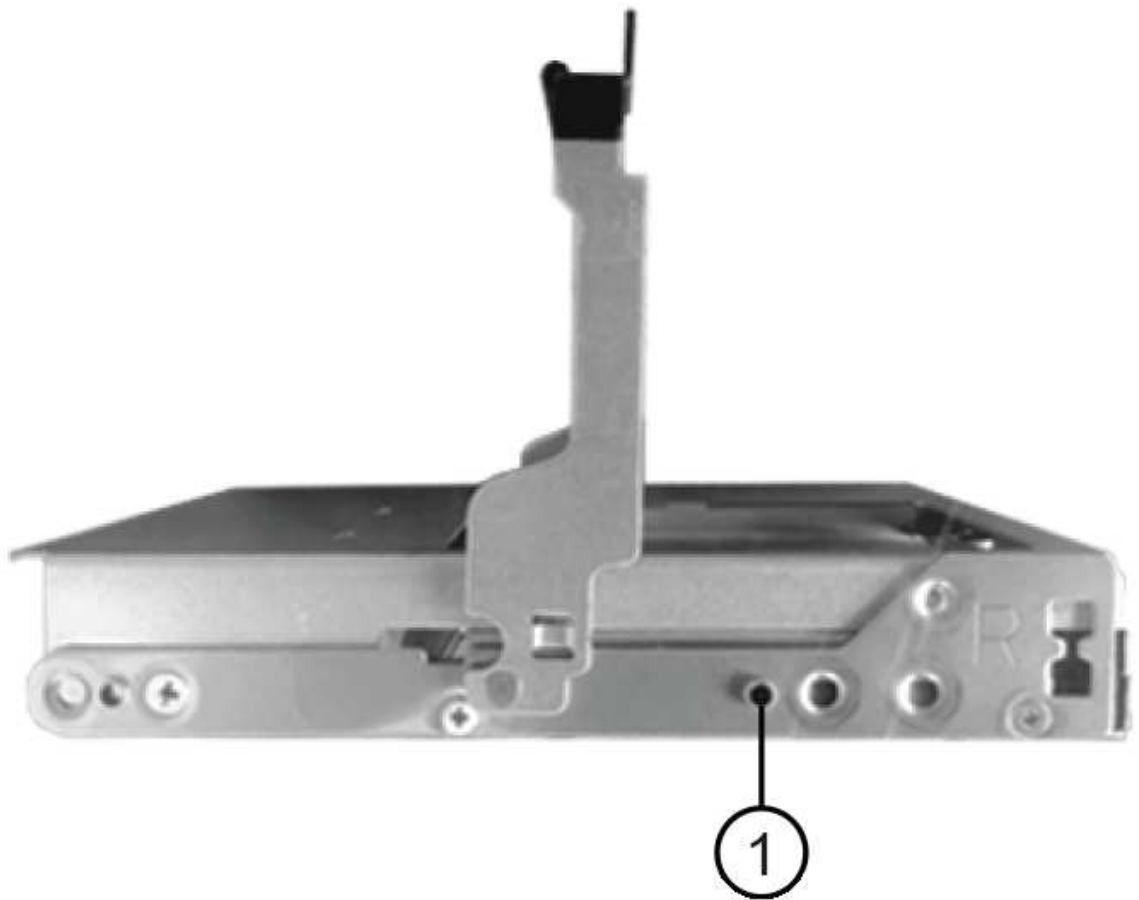

(1) Raised button on the right side of the drive

- f. Lower the drive straight down, making sure the drive is pressed all the way down into the bay, and then rotate the drive handle down until the drive snaps into place.

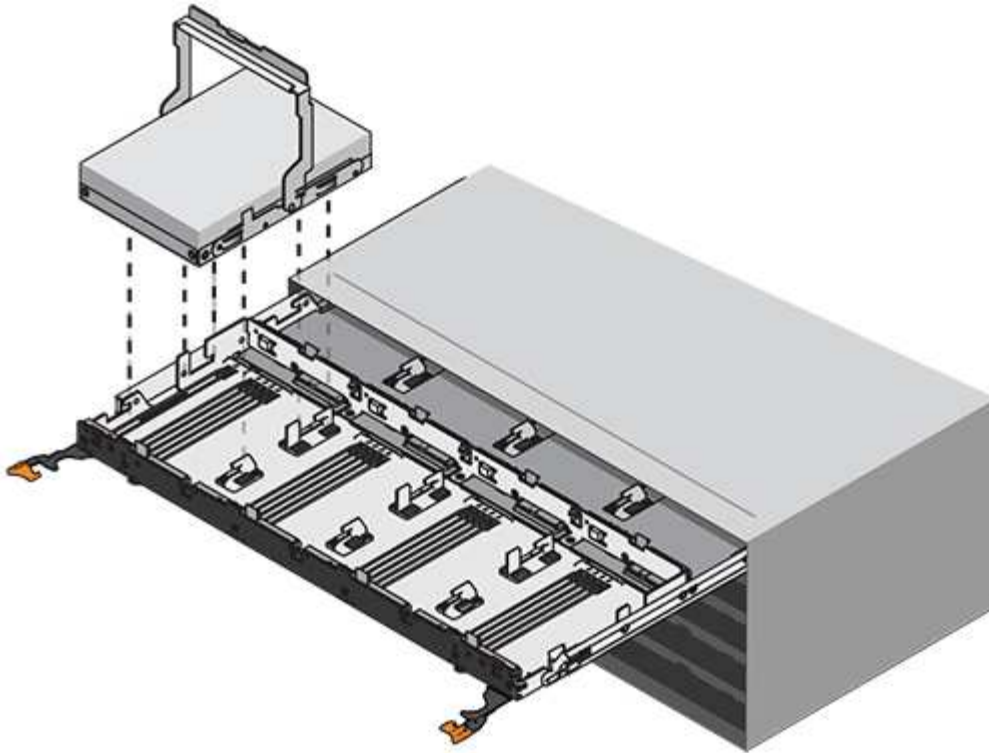

g. Repeat these steps to install all the drives.

3. Slide the drawer back into the drive shelf by pushing it from the center and closing both levers.



Risk of equipment malfunction — Make sure to completely close the drive drawer by pushing both levers. You must completely close the drive drawer to allow proper airflow and prevent overheating.

4. Attach the bezel to the front of the drive shelf.

5. If you have powered down one or more shelves, reapply power using one of the following procedures:

◦ *If you replaced a drive drawer in a **controller** shelf without *Drawer Loss Protection*:*

a. Turn on both power switches on the controller shelf.

b. Wait 10 minutes for the power-on process to complete. Confirm that both fans come on and that the amber LED on the back of the fans is off.

◦ *If you replaced a drive drawer in an **expansion** drive shelf without *Drawer Loss Protection*:*

a. Turn on both power switches on the drive shelf.

b. Confirm that both fans come on and that the amber LED on the back of the fans is off.

c. Wait two minutes before applying power to the controller shelf.

d. Turn on both power switches on the controller shelf.

e. Wait 10 minutes for the power-on process to complete. Confirm that both fans come on and that the amber LED on the back of the fans is off.

What's next?

Your drive drawer replacement is complete. You can resume normal operations.

Hot adding a drive shelf

You can add a new drive shelf while power is still applied to the other components of the storage system. You can configure, reconfigure, add, or relocate storage system capacity without interrupting user access to data.

Before you begin

Due to the complexity of this procedure, the following is recommended:

- Read all steps before beginning the procedure.
- Ensure hot adding a drive shelf is the procedure you need.

About this task

This procedure applies to hot adding a DE212C, DE224C, or DE460C drive shelf to an E4000 controller shelf.

This procedure applies to IOM12 and IOM12B drive shelves.



This procedure is for like-for-like shelf IOM hot-swaps or replacements. This means you can only replace an IOM12 module with another IOM12 module or replace an IOM12B module with another IOM12B module. (Your shelf can have two IOM12 modules or have two IOM12B modules.)



To maintain system integrity, you must follow the procedure exactly in the order presented.

Step 1: Prepare to add the drive shelf

To prepare to hot add a drive shelf, you must check for critical events and check the status of the IOMs.

Before you begin

- The power source for your storage system must be able to accommodate the power requirements of the new drive shelf. For the power specification for your drive shelf, see the [Hardware Universe](#).
- The cabling pattern for the existing storage system must match one of the applicable schemes shown in this procedure.

Steps

1. In SANtricity System Manager, select **Support > Support Center > Diagnostics**.
2. Select **Collect Support Data**.

The Collect Support Data dialog box appears.

3. Click **Collect**.

The file is saved in the Downloads folder for your browser with the name support-data.7z. The data is not automatically sent to technical support.

4. Select **Support > Event Log**.

The Event Log page displays the event data.

5. Select the heading of the **Priority** column to sort critical events to the top of the list.

6. Review the system critical events for events that have occurred in the last two to three weeks, and verify that any recent critical events have been resolved or otherwise addressed.



If unresolved critical events have occurred within the previous two to three weeks, stop the procedure and contact technical support. Continue the procedure only when the issue is resolved.

7. If you have IOMs connected to your hardware, complete the following steps. Otherwise, go to [Step 2: Install the drive shelf and apply power](#).
 - a. Select **Hardware**.
 - b. Select the **IOMs (ESMs)** icon.



The Shelf Component Settings dialog box appears with the **IOMs (ESMs)** tab selected.

- c. Make sure that the status shown for each IOM/ESM is *Optimal*.
- d. Click **Show more settings**.
- e. Confirm that the following conditions exist:
 - The number of ESMs/IOMs detected matches the number of ESMs/IOMs installed in the system and that for each drive shelf.
 - Both of the ESMs/IOMs show that communication is OK.
 - The data rate is 12Gb/s for DE212C, DE224C, and DE460C drive shelves or 6 Gb/s for other drive trays.

Step 2: Install the drive shelf and apply power

You install a new drive shelf or a previously installed drive shelf, turn on the power, and check for any LEDs that require attention.

Steps

1. If you are installing a drive shelf that has previously been installed in a storage system, remove the drives. The drives must be installed one at a time later in this procedure.

If the installation history of the drive shelf that you are installing is unknown, you should assume that it has been previously installed in a storage system.

2. Install the drive shelf in the rack that holds the storage system components.



See the installation instructions for your model for the full procedure for physical installation and power cabling. The installation instructions for your model includes notes and warnings that you must take into account to safely install a drive shelf.

3. Power on the new drive shelf, and confirm that no amber attention LEDs are illuminated on the drive shelf. If possible, resolve any fault conditions before you continue with this procedure.

Step 3: Cable your system

You connect the drive shelf to controller A, confirm IOM status, and then connect the drive shelf to controller B.

Steps

1. Connect the drive shelf to controller A.

The following figure shows an example connection between an additional drive shelf and controller A. To locate the ports on your model, see the [Hardware Universe](#).

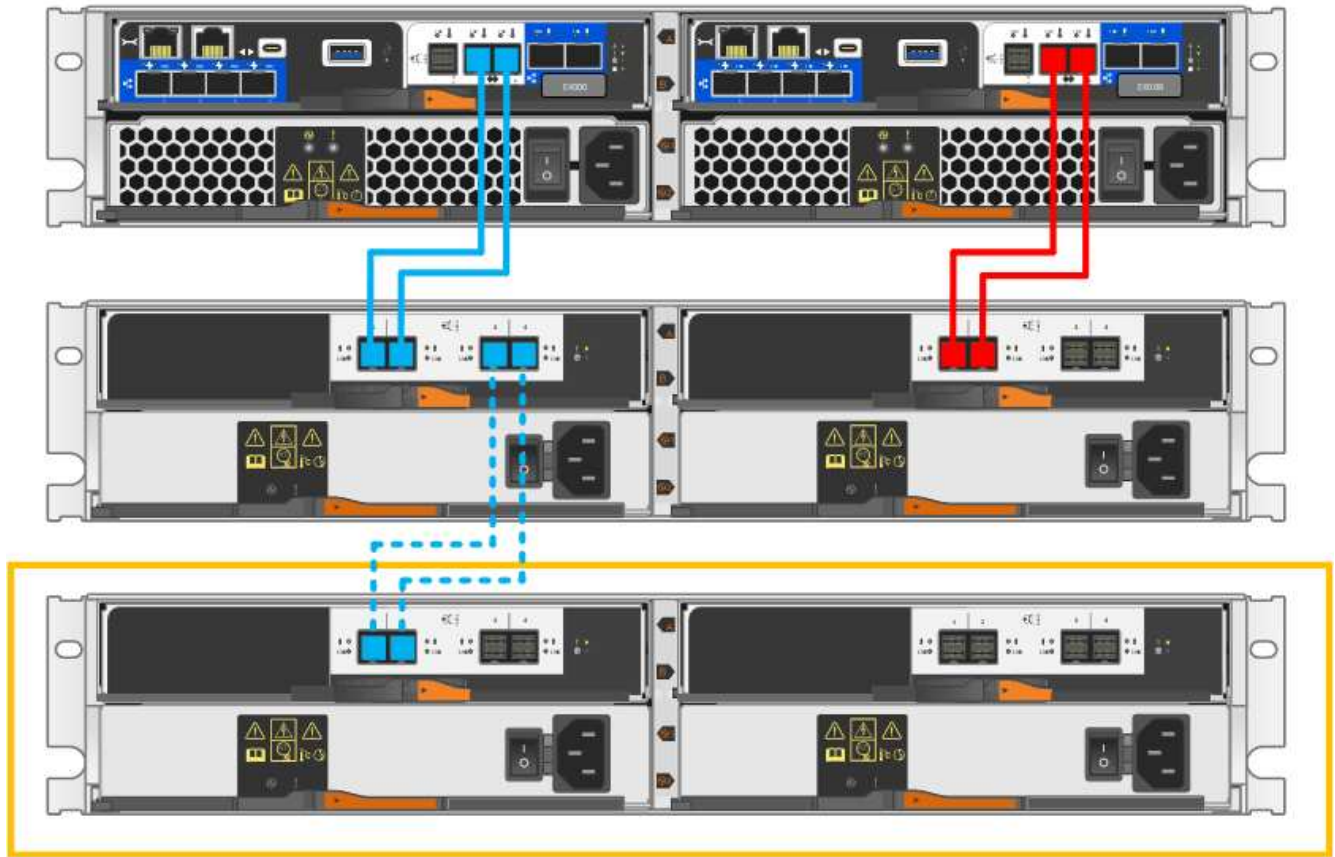

2. In SANtricity System Manager, click **Hardware**.



At this point in the procedure, you have only one active path to the controller shelf.

3. Scroll down, as necessary, to see all the drive shelves in the new storage system. If the new drive shelf is not displayed, resolve the connection issue.
4. Select the **ESMs/IOMs** icon for the new drive shelf.



The **Shelf Component Settings** dialog box appears.

5. Select the **ESMs/IOMs** tab in the **Shelf Component Settings** dialog box.
6. Select **Show more options**, and verify the following:
 - IOM/ESM A is listed.
 - Current data rate is 12 Gbps for a SAS-3 drive shelf.
 - Card communications is OK.
7. Disconnect all expansion cables from controller B.

8. Connect the drive shelf to controller B.

The following figure shows an example connection between an additional drive shelf and controller B. To locate the ports on your model, see the [Hardware Universe](#).

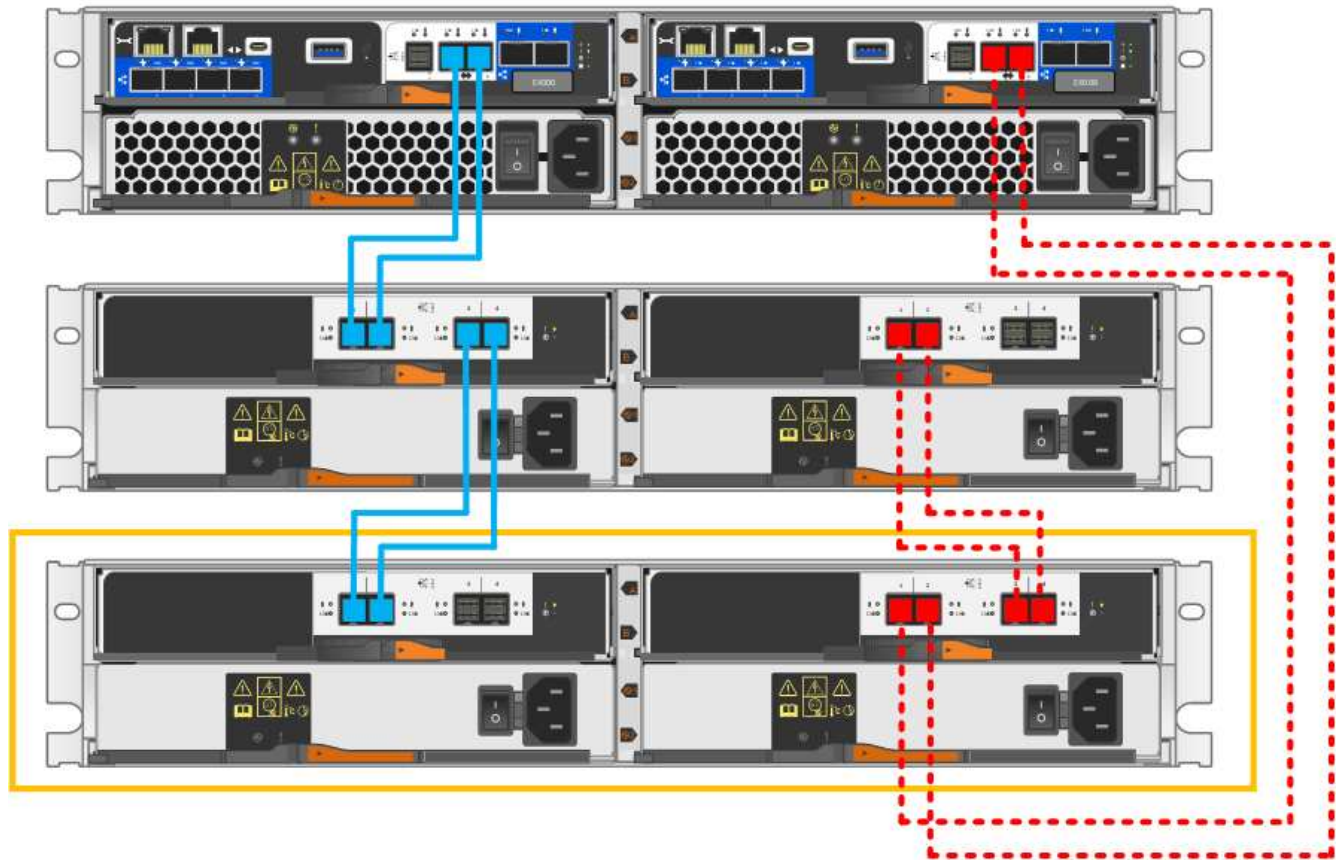

9. If it is not already selected, select the **ESMs/IOMs** tab in the **Shelf Component Settings** dialog box, and then select **Show more options**. Verify that Card communications is **YES**.



Optimal status indicates that the loss of redundancy error associated with the new drive shelf has been resolved and the storage system is stabilized.

Step 4: Complete hot add

You complete the hot add by checking for any errors and confirming that the newly added drive shelf uses the latest firmware.

Steps

1. In SANtricity System Manager, click **Home**.
2. If the link labeled **Recover from problems** appears at the center top of the page, click the link, and resolve any issues indicated in the Recovery Guru.
3. In SANtricity System Manager, click **Hardware**, and scroll down, as necessary, to see the newly added drive shelf.
4. For drives that were previously installed in a different storage system, add one drive at a time to the newly installed drive shelf. Wait for each drive to be recognized before you insert the next drive.

When a drive is recognized by the storage system, the representation of the drive slot in the **Hardware**

page displays as a blue rectangle.

5. Select **Support > Support Center > Support Resources** tab.
6. Click the **Software and Firmware Inventory** link, and check which versions of the IOM/ESM firmware and the drive firmware are installed on the new drive shelf.



You might need to scroll down the page to locate this link.

7. If necessary, upgrade the drive firmware.

IOM/ESM firmware automatically upgrades to the latest version unless you have disabled the upgrade feature.

The hot add procedure is complete. You can resume normal operations.

Copyright information

Copyright © 2025 NetApp, Inc. All Rights Reserved. Printed in the U.S. No part of this document covered by copyright may be reproduced in any form or by any means—graphic, electronic, or mechanical, including photocopying, recording, taping, or storage in an electronic retrieval system—without prior written permission of the copyright owner.

Software derived from copyrighted NetApp material is subject to the following license and disclaimer:

THIS SOFTWARE IS PROVIDED BY NETAPP “AS IS” AND WITHOUT ANY EXPRESS OR IMPLIED WARRANTIES, INCLUDING, BUT NOT LIMITED TO, THE IMPLIED WARRANTIES OF MERCHANTABILITY AND FITNESS FOR A PARTICULAR PURPOSE, WHICH ARE HEREBY DISCLAIMED. IN NO EVENT SHALL NETAPP BE LIABLE FOR ANY DIRECT, INDIRECT, INCIDENTAL, SPECIAL, EXEMPLARY, OR CONSEQUENTIAL DAMAGES (INCLUDING, BUT NOT LIMITED TO, PROCUREMENT OF SUBSTITUTE GOODS OR SERVICES; LOSS OF USE, DATA, OR PROFITS; OR BUSINESS INTERRUPTION) HOWEVER CAUSED AND ON ANY THEORY OF LIABILITY, WHETHER IN CONTRACT, STRICT LIABILITY, OR TORT (INCLUDING NEGLIGENCE OR OTHERWISE) ARISING IN ANY WAY OUT OF THE USE OF THIS SOFTWARE, EVEN IF ADVISED OF THE POSSIBILITY OF SUCH DAMAGE.

NetApp reserves the right to change any products described herein at any time, and without notice. NetApp assumes no responsibility or liability arising from the use of products described herein, except as expressly agreed to in writing by NetApp. The use or purchase of this product does not convey a license under any patent rights, trademark rights, or any other intellectual property rights of NetApp.

The product described in this manual may be protected by one or more U.S. patents, foreign patents, or pending applications.

LIMITED RIGHTS LEGEND: Use, duplication, or disclosure by the government is subject to restrictions as set forth in subparagraph (b)(3) of the Rights in Technical Data -Noncommercial Items at DFARS 252.227-7013 (FEB 2014) and FAR 52.227-19 (DEC 2007).

Data contained herein pertains to a commercial product and/or commercial service (as defined in FAR 2.101) and is proprietary to NetApp, Inc. All NetApp technical data and computer software provided under this Agreement is commercial in nature and developed solely at private expense. The U.S. Government has a non-exclusive, non-transferrable, nonsublicensable, worldwide, limited irrevocable license to use the Data only in connection with and in support of the U.S. Government contract under which the Data was delivered. Except as provided herein, the Data may not be used, disclosed, reproduced, modified, performed, or displayed without the prior written approval of NetApp, Inc. United States Government license rights for the Department of Defense are limited to those rights identified in DFARS clause 252.227-7015(b) (FEB 2014).

Trademark information

NETAPP, the NETAPP logo, and the marks listed at <http://www.netapp.com/TM> are trademarks of NetApp, Inc. Other company and product names may be trademarks of their respective owners.