



Cisco Nexus 3132Q-V switches

ONTAP Systems Switches

NetApp
June 02, 2022

Table of Contents

- Cisco Nexus 3132Q-V switches 1
 - Cisco Nexus 3132Q-V switches 1
 - Install a Cisco Nexus 3132Q-V cluster switch and a pass-through panel in a NetApp cabinet 2
 - Set up 6
 - Install NX-OS software and RCFs on Cisco Nexus 3132Q-V cluster switches 34
 - Migrate to a two-node switched cluster with Cisco Nexus 3132Q-V cluster switches 61
 - Replace Cisco Nexus 3132Q-V cluster switches 81
 - Replace a Cisco Nexus 5596 cluster switch with a Cisco Nexus 3132Q-V cluster switch 105
 - Replace CN1610 cluster switches with Cisco Nexus 3132Q-V cluster switches 134

Cisco Nexus 3132Q-V switches

Cisco Nexus 3132Q-V switches

You can use the Cisco Nexus 3132Q-V switches as cluster switches in your AFF or FAS cluster.

- You can install NX-OS and reference configuration files (RCFs) on the Cisco Nexus 3132Q-V cluster switch.
- You can migrate from a two-node switchless cluster environment to a two-node switched environment using Cisco Nexus 3132Q-V cluster switches.
- You can replace a defective Cisco Nexus 3132Q-V switch in a cluster and download the switch operating system and reference configuration file.
- You can replace Cisco Nexus 5596, Nexus 5020, or Nexus 5010 cluster switches with Cisco Nexus 3132Q-V switches.
- You can replace NetApp CN1610 switches with Cisco Nexus 3132Q-V cluster switches.

Available documentation

The following table lists the documentation available for the Cisco Nexus 3132Q-V switches.

Title	Description
<i>Install a Cisco® Nexus 3132Q-V cluster switch and pass-through panel in a NetApp® cabinet</i>	Describes how to install the pass-through panel in system cabinets where power connectors are at the front of the chassis and power distribution units are located in the rear of the chassis.
<i>Setup the Cisco® Nexus 3132Q-V cluster switches</i>	Describes how to setup and configure your Cisco Nexus 3132Q-V cluster switches.
<i>Install NX-OS and Reference Configuration Files (RCFs)</i>	Describes how to install NX-OS and reference configuration files (RCFs) on Nexus 3132Q-V cluster switch.
<i>Replace Cisco Nexus 5596 cluster switches with Cisco Nexus 3132Q-V cluster switches</i>	Describes how to migrate from environments that use older Cisco switches to environments that use Cisco 3132Q-V switches.
<i>Replace CN1610 cluster switches with Cisco Nexus 3132Q-V cluster switches</i>	Describes the procedure to replace a CN1610 switch with a Cisco Nexus 3132Q-V cluster switch.
<i>Migrate from a two-node Switchless Cluster</i>	Describes how to migrate from a two-node switchless cluster environment to a two-node switched environment using Cisco Nexus 3132Q-V cluster switches.

Install a Cisco Nexus 3132Q-V cluster switch and a pass-through panel in a NetApp cabinet

You can install the Cisco Nexus 3132Q-V switch and pass-through panel in a NetApp cabinet with the standard brackets that are included with the switch.

Before you begin

You must have reviewed the initial preparation requirements, kit contents, and safety precautions.

[Cisco Nexus 3000 Series Hardware Installation Guide](#)

About this task

- For each switch, you must supply the eight 10-32 or 12-24 screws and clip nuts to mount the brackets and slider rails to the front and rear cabinet posts.
- You must use the Cisco standard rail kit to install the switch in a NetApp cabinet.



The jumper cords are not included with the pass-through kit and should be included with your switches. If they were not shipped with the switches, you can order them from NetApp (part number X1558A-R6).

Steps

1. Install the pass-through blanking panel in the NetApp cabinet.

The pass-through panel kit is available from NetApp (part number X8784-R6).

The NetApp pass-through panel kit contains the following hardware:

- One pass-through blanking panel
- Four 10-32 x .75 screws
- Four 10-32 clip nuts
 - a. Determine the vertical location of the switches and blanking panel in the cabinet.

In this procedure, the blanking panel will be installed in U40.
 - b. Install two clip nuts on each side in the appropriate square holes for front cabinet rails.
 - c. Center the panel vertically to prevent intrusion into adjacent rack space, and then tighten the screws.
 - d. Insert the female connectors of both 48-inch jumper cords from the rear of the panel and through the brush assembly.

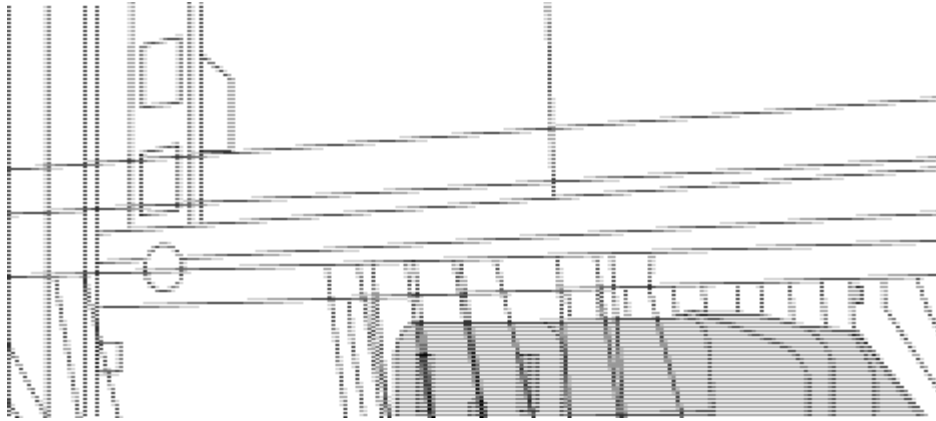

1. Female connector of the jumper cord.
2. Install the rack-mount brackets on the Nexus 3132Q-V switch chassis.
 - a. Position a front rack-mount bracket on one side of the switch chassis so that the mounting ear is aligned with the chassis faceplate (on the PSU or fan side), and then use four M4 screws to attach the bracket to the chassis.

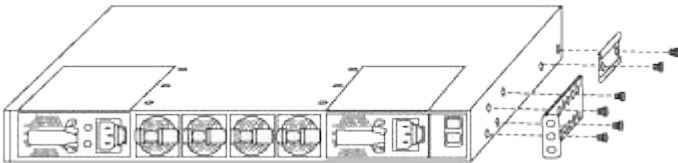

- b. Repeat step 2a with the other front rack-mount bracket on the other side of the switch.
 - c. Install the rear rack-mount bracket on the switch chassis.
 - d. Repeat step 2c with the other rear rack-mount bracket on the other side of the switch.
3. Install the clip nuts in the square hole locations for all four IEA posts.

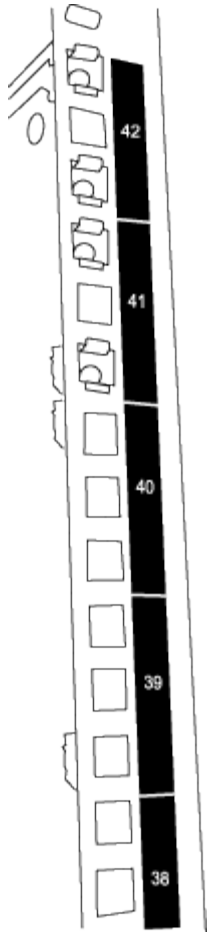

The two 3132Q-V switches will always be mounted in the top 2U of the cabinet RU41 and 42.

4. Install the slider rails in the cabinet.

- a. Position the first slider rail at the RU42 mark on the back side of the rear left post, insert screws with the matching thread type, and then tighten the screws with your fingers.

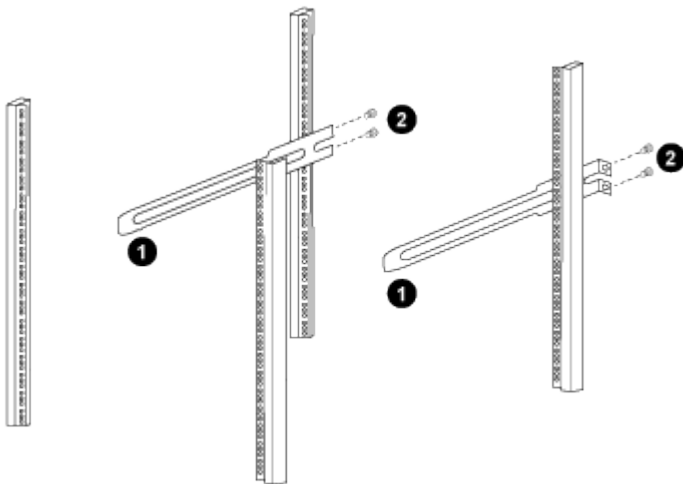

1. As you gently slide the slider rail, align it to the screw holes in the rack.
2. Tighten the screws of the slider rails to the cabinet posts.

- b. Repeat step 4a for the right side rear post.

c. Repeat steps 4a and 4b at the RU41 locations on the cabinet.

5. Install the switch in the cabinet.



This step requires two people: one person to support the switch from the front and another to guide the switch into the rear slider rails.

a. Position the back of the switch at RU41.

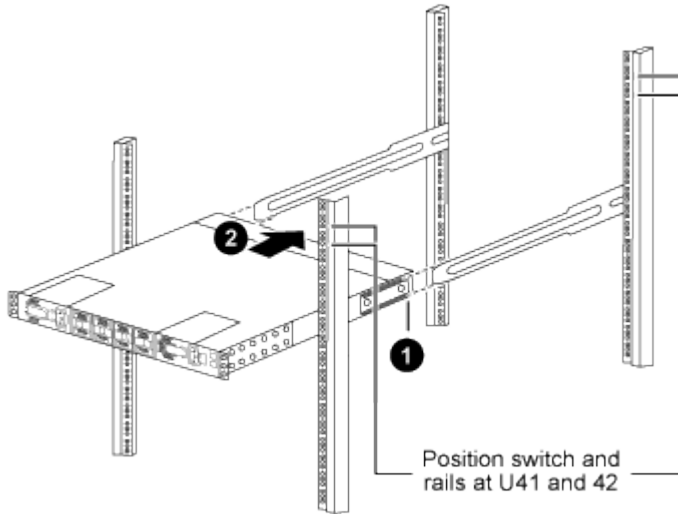

1. As the chassis is pushed toward the rear posts, align the two rear rack-mount guides with the slider rails.

2. Gently slide the switch until the front rack-mount brackets are flush with the front posts.

b. Attach the switch to the cabinet.

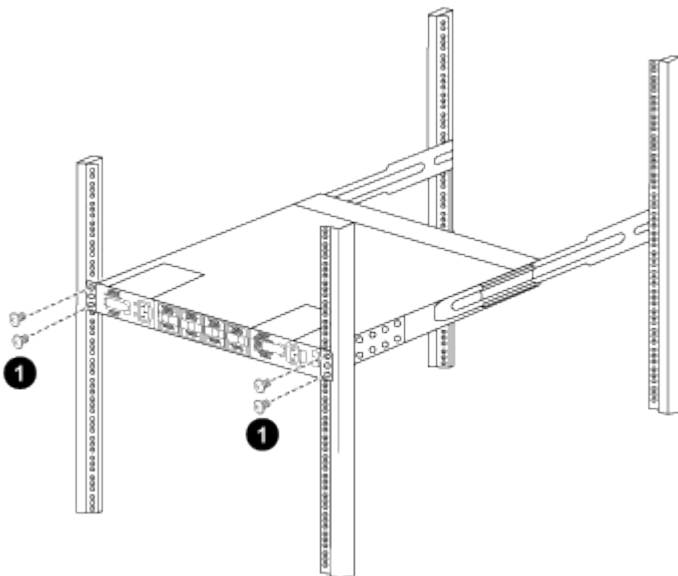

1. With one person holding the front of the chassis level, the other person should fully tighten the four rear screws to the cabinet posts.

c. With the chassis now supported without assistance, fully tighten the front screws to the posts.

d. Repeat steps 5a through 5c for the second switch at the RU42 location.



By using the fully installed switch as a support, it is not necessary to hold the front of the second switch during the installation process.

6. When the switches are installed, connect the jumper cords to the switch power inlets.
7. Connect the male plugs of both jumper cords to the closest available PDU outlets.



To maintain redundancy, the two cords must be connected to different PDUs.

8. Connect the management port on each 3132Q-V switch to either of the management switches (if ordered) or connect them directly to your management network.

The management port is the upper-right port located on the PSU side of the switch. The CAT6 cable for each switch needs to be routed through the pass-through panel after the switches are installed to connect to the management switches or management network.

Set up

Set up the switches

If you do not already have the required configuration information and documentation, you need to gather that information before setting up your cluster and management network switches.

- You must have access to an HTTP, FTP or TFTP server at the installation site to download the applicable NX-OS and reference configuration file (RCF) releases.
- You must have the required cluster network and management network switch documentation.

See [Required documentation](#) for more information.

- You must have the required controller documentation and ONTAP documentation.

[NetApp documentation](#)

- You must have the applicable licenses, network and configuration information, and cables.
- You must have the completed cabling worksheets.



Due to the complexity that can result from illustrating layers of cabling, this guide does not provide cabling graphics. This guide does provide sample worksheets with recommended port assignments and blank worksheets that you can use to set up your cluster.



For more information refer to the [Hardware Universe](#).

- All Cisco cluster network and management network switches arrive with the standard Cisco factory-default configuration. These switches also have the current version of the NX-OS software but do not have the RCFs loaded.



You must download the applicable NetApp cluster network and management network RCFs from the NetApp Support Site at mysupport.netapp.com for the switches that you receive.

- In addition, you might need to install the required configuration file to support the Cluster Switch Health Monitor (CSHM) for the 92300YC cluster switches. See [Installing the Cluster Switch Health Monitor \(CSHM\) configuration file for 92300YC switches](#) for details.

Steps

1. Rack the cluster network and management network switches and controllers.

If you are installing your...	Then...
Cisco Nexus 9336C-FX2 in a NetApp system cabinet	See the <i>Installing a Cisco Nexus 9336C-FX2 cluster switch and pass-through panel in a NetApp cabinet</i> guide for instructions to install the switch in a NetApp cabinet.
Cisco Nexus 3232C in a NetApp system cabinet	See the <i>Installing a Cisco Nexus 3232C cluster switch and pass-through panel in a NetApp cabinet</i> guide for instructions to install the switch in a NetApp cabinet.
Cisco Nexus 3132Q-V in a NetApp system cabinet	See the <i>Installing a Cisco Nexus 3132Q-V cluster switch and pass-through panel in a NetApp cabinet</i> guide for instructions to install the switch in a NetApp cabinet.
Equipment in a Telco rack	See the procedures provided in the switch hardware installation guides and the NetApp installation and setup instructions.
Cisco Nexus 5596UP/5596T in a NetApp system cabinet	See the <i>Installing a Cisco Nexus 5596 cluster switch and pass-through panel in a NetApp cabinet</i> guide for instructions to install the switch in a NetApp cabinet.

2. Cable the cluster network and management network switches to the controllers using the completed cabling worksheets.
3. Power on the cluster network and management network switches and controllers.
4. Perform an initial configuration of the cluster network switches based on information provided in [Required configuration information](#).
5. Verify the configuration choices you made in the display that appears at the end of the setup, and make sure that you save the configuration.
6. Check the version on the cluster network switches, and if necessary, download the NetApp-supported version of the software to the switches.

If you download the NetApp-supported version of the software, then you must also download the *NetApp Cluster Network Switch Reference Configuration File* and merge it with the configuration you saved in Step 5. You can download the file and the instructions from the [Cisco Ethernet Switches](#) page.

7. Check the software version on the network switches and, if necessary, download the NetApp-supported version of the software to the switches. If you have your own switches, refer to the [Cisco site](#).

If you download the NetApp-supported version of the software, then you must also download the *NetApp Management Network Switch Reference Configuration File* and merge it with the configuration you saved in Step 5. You can download the file and instructions from the [Cisco Ethernet Switches](#) page.

Related information

[Required cluster configuration information](#)

[Required documentation](#)

[Sample and blank cabling worksheets](#)

Required cluster configuration information

To configure your cluster, you need the appropriate number and type of cables and cable connectors for your switches. Depending on the type of switch you are initially configuring, you need to connect to the switch console port with the included console cable; you also need to provide specific network information.

Required network information for all switches

You need the following network information for all switch configurations:

- IP subnet for management network traffic
- Host names and IP addresses for each of the storage system controllers and all applicable switches
- Most storage system controllers are managed through the e0M interface by connecting to the Ethernet service port (wrench icon). On AFF A800 and AFF A700 systems, the e0M interface uses a dedicated Ethernet port.

Refer to the [Hardware Universe](#) for latest information.

Required network information for Cisco Nexus 9336C-FX2, 92300YC, 3232C, 3132Q-V, and 5596UP/5596T switches

For the Cisco Nexus 9336C-FX2, 92300YC, 3232C, 3132Q-V, and 5596UP/5596T switches, you need to provide applicable responses to the following initial setup questions when you first boot the switch. Your site's security policy defines the responses and services to enable.

- Abort Auto Provisioning and continue with normal setup? (yes/no)

Respond with **yes**. The default is no.

- Do you want to enforce secure password standard? (yes/no)

Respond with **yes**. The default is yes.

- Enter the password for admin:

The default password is "admin"; you must create a new, strong password. A weak password can be rejected.

- Would you like to enter the basic configuration dialog? (yes/no)

Respond with **yes** at the initial configuration of the switch.

- Create another login account? (yes/no)

Your answer depends on your site's policies on alternate administrators. The default is **no**.

- Configure read-only SNMP community string? (yes/no)

Respond with **no**. The default is no.

- Configure read-write SNMP community string? (yes/no)

Respond with **no**. The default is no.

- Enter the switch name.

The switch name is limited to 63 alphanumeric characters.

- Continue with Out-of-band (mgmt0) management configuration? (yes/no)

Respond with **yes** (the default) at that prompt. At the mgmt0 IPv4 address: prompt, enter your IP address: ip_address.

- Configure the default-gateway? (yes/no)

Respond with **yes**. At the IPv4 address of the default-gateway: prompt, enter your default_gateway.

- Configure advanced IP options? (yes/no)

Respond with **no**. The default is no.

- Enable the telnet service? (yes/no)

Respond with **no**. The default is no.

- Enabled SSH service? (yes/no)

Respond with **yes**. The default is yes.



SSH is recommended when using Cluster Switch Health Monitor (CSHM) for its log collection features. SSHv2 is also recommended for enhanced security.

- Enter the type of SSH key you want to generate (dsa/rsa/rsa1). The default is **rsa**.
- Enter the number of key bits (1024-2048).
- Configure the NTP server? (yes/no)

Respond with **no**. The default is no.

- Configure default interface layer (L3/L2):

Respond with **L2**. The default is L2.

- Configure default switch port interface state (shut/noshut):

Respond with **noshut**. The default is noshut.

- Configure CoPP system profile (strict/moderate/lenient/dense):

Respond with **strict**. The default is strict.

- Would you like to edit the configuration? (yes/no)

You should see the new configuration at this point. Review and make any necessary changes to the

configuration you just entered. Respond with **no** at the prompt if you are satisfied with the configuration. Respond with **yes** if you want to edit your configuration settings.

- Use this configuration and save it? (yes/no)

Respond with **yes** to save the configuration. This automatically updates the kickstart and system images.



If you do not save the configuration at this stage, none of the changes will be in effect the next time you reboot the switch.

For more information about the initial configuration of your switch, see the following guides:

[Cisco Nexus 9336C-FX2 Installation and Upgrade Guides](#)

[Cisco Nexus 92300YC Installation and Upgrade Guides](#)

[Cisco Nexus 5000 Series Hardware Installation Guide](#)

[Cisco Nexus 3000 Series Hardware Installation Guide](#)

Install the Cluster Switch Health Monitor (CSHM) configuration file for 92300YC switches

You can use this procedure to install the applicable configuration file for cluster switch health monitoring of Nexus 92300YC cluster switches. In ONTAP releases 9.5P7 and earlier and 9.6P2 and earlier, you must download the cluster switch health monitor configuration file separately. In ONTAP releases 9.5P8 and later, 9.6P3 and later, and 9.7 and later, the cluster switch health monitor configuration file is bundled with ONTAP.

Before you setup the switch health monitor for 92300YC cluster switches, you must ensure that the ONTAP cluster is up and running.



It is advisable to enable SSH in order to use all features available in CSHM.

1. Download the cluster switch health monitor configuration zip file based on the corresponding ONTAP release version. This file is available from the [NetApp Software download](#) page.
 - a. On the Software download page, select **Switch Health Monitor Configuration Files**
 - b. Select Platform = **ONTAP** and click **Go!**
 - c. On the Switch Health Monitor Configuration Files for ONTAP page, click **View & Download**
 - d. On the Switch Health Monitor Configuration Files for ONTAP - Description page, click **Download** for the applicable cluster switch model, for example: **Cisco Nexus 92300YC**
 - e. On the End User License Agreement page, click **Accept**
 - f. On the Switch Health Monitor Configuration Files for ONTAP - Download page, select the applicable configuration file, for example, **Cisco_Nexus_92300YC.zip**
2. Upload the applicable zip file to your internal web server where the IP address is X.X.X.X.

For an internal web server IP address of 192.168.2.20 and assuming a /usr/download directory exists, you can upload your zip file to your web server using scp:

```
% scp Cisco_Nexus_92300YC.zip
admin@192.168.2.20:/usr/download/Cisco_Nexus_92300YC.zip
```

3. Access the advanced mode setting from one of the ONTAP systems in the cluster, using the command `set-privilege advanced`:

```
cluster1::> set -privilege advanced
```

4. Run the switch health monitor configure command `system cluster-switch configure-health-monitor -node * -package-url X.X.X/location_to_download_zip_file`:

```
cluster1::> system cluster-switch configure-health-monitor -node *
-package-url 192.168.2.20/usr/download/Cisco_Nexus_92300YC.zip
```

5. Verify that the command output contains the text string "downloaded package processed successfully". If an error occurs, contact NetApp support.
6. Run the command `system cluster-switch show` on the ONTAP system and ensure that the cluster switches are discovered with the monitored field set to "True".

```
cluster1::> system cluster-switch show
```



If at any time you revert to an earlier version of ONTAP, you will need to install the CSHM configuration file again to enable switch health monitoring of 92300YC cluster switches.

Required documentation

You need specific switch and controller documentation to set up your ONTAP cluster.

Required documentation for cluster network switches

To set up the Cisco Nexus 9336C-FX2 and 92300YC switches, you need the following documentation from the [Cisco Nexus 9000 Series Switches Support](#) page:

Document title	Description
<i>Nexus 9000 Series Hardware Installation Guide</i>	Provides detailed information about site requirements, switch hardware details, and installation options.
<i>Cisco Nexus 9000 Series Switch Software Configuration Guides</i> (choose the guide for the NX-OS release installed on your switches)	Provides initial switch configuration information that you need before you can configure the switch for ONTAP operation.

Document title	Description
<i>Cisco Nexus 9000 Series NX-OS Software Upgrade and Downgrade Guide</i> (choose the guide for the NX-OS release installed on your switches)	Provides information on how to downgrade the switch to ONTAP supported switch software, if necessary.
<i>Cisco Nexus 9000 Series NX-OS Command Reference Master Index</i>	Provides links to the various command references provided by Cisco.
<i>Cisco Nexus 9000 MIBs Reference</i>	Describes the Management Information Base (MIB) files for the Nexus 9000 switches.
<i>Nexus 9000 Series NX-OS System Message Reference</i>	Describes the system messages for Cisco Nexus 9000 series switches, those that are informational, and others that might help diagnose problems with links, internal hardware, or the system software.
<i>Cisco Nexus 9000 Series NX-OS Release Notes</i> (choose the notes for the NX-OS release installed on your switches)	Describes the features, bugs, and limitations for the Cisco Nexus 9000 Series.
Regulatory Compliance and Safety Information for Cisco Nexus 9000 Series	Provides international agency compliance, safety, and statutory information for the Nexus 9000 series switches.

To set up the Cisco Nexus 3232C and 3132Q-V switches, you need the following documentation from the [Cisco Nexus 3000 Series Switches Support](#) page:

Document title	Description
<i>Nexus 3000 Series Hardware Installation Guide</i>	Provides detailed information about site requirements, switch hardware details, and installation options.
<i>Cisco Nexus 3000 Series Switch Software Configuration Guides</i> (choose the guide for the NX-OS release installed on your switches)	Provides initial switch configuration information that you need before you can configure the switch for ONTAP operation.
<i>Cisco Nexus 3000 Series NX-OS Software Upgrade and Downgrade Guide</i> (choose the guide for the NX-OS release installed on your switches)	Provides information on how to downgrade the switch to ONTAP supported switch software, if necessary.
<i>Cisco Nexus 3000 Series NX-OS Command Reference Master Index</i>	Provides links to the various command references provided by Cisco.

Document title	Description
<i>Cisco Nexus 3000 MIBs Reference</i>	Describes the Management Information Base (MIB) files for the Nexus 3000 switches.
<i>Nexus 3000 Series NX-OS System Message Reference</i>	Describes the system messages for Cisco Nexus 3000 series switches, those that are informational, and others that might help diagnose problems with links, internal hardware, or the system software.
<i>Cisco Nexus 3000 Series NX-OS Release Notes (choose the notes for the NX-OS release installed on your switches)</i>	Describes the features, bugs, and limitations for the Cisco Nexus 3000 Series.
Regulatory, Compliance, and Safety Information for the Cisco Nexus 6000, Cisco Nexus 5000 Series, Cisco Nexus 3000 Series, and Cisco Nexus 2000 Series	Provides international agency compliance, safety, and statutory information for the Nexus 3000 series switches.

To set up the Cisco Nexus 5596 switch, you need the following documents from [Cisco Nexus 5000 Series Switches Support](#) page:

Document title	Description
<i>Nexus 5000 Series Hardware Installation Guide</i>	Provides detailed information about site requirements, switch hardware details, and installation options.
<i>Cisco Nexus 5000 Series Switch Software Configuration Guide (choose the guide for the software you are using)</i>	Provides initial switch configuration information that you need before you can configure the switch for ONTAP operation.
<i>Cisco Nexus 5000 Series NX-OS Software Upgrade and Downgrade Guide</i>	Provides information about how to downgrade the switch to the supported ONTAP switch software, if necessary.
<i>Cisco Nexus 5000 Series NX-OS Command Reference Master Index</i>	Provides an alphabetical list of all the commands supported for a specific NX-OS release.
<i>Cisco Nexus 5000 and Nexus 2000 MIBs Reference</i>	Describes the Management Information Base (MIB) files for the Nexus 5000 switches.
<i>Nexus 5000 Series NX-OS System Message Reference</i>	Describes troubleshooting information.

Document title	Description
<i>Regulatory, Compliance, and Safety Information for the Cisco Nexus 6000 Series, Cisco Nexus 5000 Series, Cisco Nexus 3000 Series, and Cisco Nexus 2000 Series</i>	Provides international agency compliance, safety, and statutory information for the Nexus 5000 series switches.

Required documentation for supported ONTAP systems

To set up an ONTAP system, you need the following documents for your version of the operating system from the [ONTAP 9 Documentation Center](#).

Name	Description
Controller-specific <i>Installation and Setup Instructions</i>	Describes how to install NetApp hardware.
ONTAP documentation	Provides detailed information about all aspects of the ONTAP releases.
Hardware Universe	Provides NetApp hardware configuration and compatibility information.

Rail kit and cabinet documentation

To install a Cisco switch in a NetApp cabinet, see the following hardware documentation:

Name	Description
42U System Cabinet, Deep Guide	Describes the FRUs associated with the 42U system cabinet, and provides maintenance and FRU replacement instructions.
Installing a Cisco Nexus 3232C cluster switch and pass-through panel in a NetApp cabinet	Describes how to install a Cisco Nexus 3232C switch in a four-post NetApp cabinet.
Installing a Cisco Nexus 3132Q-V switch and pass-through panel in a NetApp Cabinet	Describes how to install a Cisco Nexus 3132Q-V switch in a four-post NetApp cabinet.
Installing a Cisco Nexus 5596 switch and pass-through panel in a NetApp Cabinet	Describes how to install a Cisco Nexus 5596 switch in a NetApp cabinet.

Considerations for using Smart Call Home

Smart Call Home monitors the hardware and software components on your network, to generate an email-based notification of critical system conditions. When an event occurs on your device, Smart Call Home raises an alert to all the recipients that are configured in your destination profile.

You must configure a cluster network switch to communicate using email with the Smart Call Home system. You can optionally set up your cluster network switch to take advantage of Cisco's embedded Smart Call Home support feature.

Before you can use Smart Call Home feature, you need to be aware of the following considerations:

- An email server must be in place.
- The switch must have IP connectivity to the email server.
- The contact name (SNMP server contact), phone number, and street address information must be configured.
- This is required to determine the origin of messages received.
- A CCO ID must be associated with an appropriate Cisco SMARTnet Service contract for your company.
- Cisco SMARTnet Service must be in place for the device to be registered.

The Cisco support site contains information about the commands to configure Smart Call Home.

[Cisco support site](#)

Sample and blank cabling worksheets

The sample cabling worksheets provide examples of recommended port assignments from the switches to the controllers. The blank worksheets provide a template that you can use in setting up your cluster.

Cisco Nexus 9336C-FX2 cabling worksheet

If you want to document the supported platforms, you must complete the blank cabling worksheet by using the completed sample cabling worksheet as a guide.

Sample cabling worksheet

The sample port definition on each pair of switches is as follows:

Cluster switch A		Cluster switch B	
Switch port	Node and port usage	Switch port	Node and port usage
1	4x10GbE node 1	1	4x10GbE node 1
2	4x10GbE node 2	2	4x10GbE node 2
3	4x10GbE node 3	3	4x10GbE node 3
4	4x25GbE node 4	4	4x25GbE node 4
5	4x25GbE node 5	5	4x25GbE node 5
6	4x25GbE node 6	6	4x25GbE node 6

Cluster switch A		Cluster switch B	
7	4x100GbE node 7	7	4x100GbE node 7
8	4x100GbE node 8	8	4x100GbE node 8
9	4x100GbE node 9	9	4x100GbE node 9
10	4x100GbE node 10	10	4x100GbE node 10
11	4x100GbE node 11	11	4x100GbE node 11
12	4x100GbE node 12	12	4x100GbE node 12
13	4x100GbE node 13	13	4x100GbE node 13
14	4x100GbE node 14	14	4x100GbE node 14
15	4x100GbE node 15	15	4x100GbE node 15
16	4x100GbE node 16	16	4x100GbE node 16
17	4x100GbE node 17	17	4x100GbE node 17
18	4x100GbE node 18	18	4x100GbE node 18
19	4x100GbE node 19	19	4x100GbE node 19
20	4x100GbE node 20	20	4x100GbE node 20
21	4x100GbE node 21	21	4x100GbE node 21
22	4x100GbE node 22	22	4x100GbE node 22
23	4x100GbE node 23	23	4x100GbE node 23
24	4x100GbE node 24	24	4x100GbE node 24
25 through 34	Reserved	25 through 34	Reserved
35	100G ISL to switch B port 35	35	100G ISL to switch A port 35
36	100G ISL to switch B port 36	36	100G ISL to switch A port 36

Blank cabling worksheet

You can use the blank cabling worksheet to document the platforms that are supported as nodes in a cluster. The *Supported Cluster Connections* section of the *Hardware Universe* defines the cluster ports used by the platform.

Cluster switch A		Cluster switch B	
1		1	
2		2	
3		3	
4		4	
5		5	
6		6	
7		7	
8		8	
9		9	
10		10	
11		11	
12		12	
13		13	
14		14	
15		15	
16		16	
17		17	
18		18	
19		19	

Cluster switch A		Cluster switch B	
20		20	
21		21	
22		22	
23		23	
24		24	
25 through 34	Reserved	25 through 34	Reserved
35	100G ISL to switch B port 35	35	100G ISL to switch A port 35
36	100G ISL to switch B port 36	36	100G ISL to switch A port 36

Cisco Nexus 92300YC cabling worksheet

If you want to document the supported platforms, you must complete the blank cabling worksheet by using the completed sample cabling worksheet as a guide.

Sample cabling worksheet

The sample port definition on each pair of switches is as follows:

Cluster switch A		Cluster switch B	
Switch port	Node and port usage	Switch port	Node and port usage
1	10/25 GbE node	1	10/25 GbE node
2	10/25 GbE node	2	10/25 GbE node
3	10/25 GbE node	3	10/25 GbE node
4	10/25 GbE node	4	10/25 GbE node
5	10/25 GbE node	5	10/25 GbE node
6	10/25 GbE node	6	10/25 GbE node
7	10/25 GbE node	7	10/25 GbE node

Cluster switch A		Cluster switch B	
8	10/25 GbE node	8	10/25 GbE node
9	10/25 GbE node	9	10/25 GbE node
10	10/25 GbE node	10	10/25 GbE node
11	10/25 GbE node	11	10/25 GbE node
12	10/25 GbE node	12	10/25 GbE node
13	10/25 GbE node	13	10/25 GbE node
14	10/25 GbE node	14	10/25 GbE node
15	10/25 GbE node	15	10/25 GbE node
16	10/25 GbE node	16	10/25 GbE node
17	10/25 GbE node	17	10/25 GbE node
18	10/25 GbE node	18	10/25 GbE node
19	10/25 GbE node	19	10/25 GbE node
20	10/25 GbE node	20	10/25 GbE node
21	10/25 GbE node	21	10/25 GbE node
22	10/25 GbE node	22	10/25 GbE node
23	10/25 GbE node	23	10/25 GbE node
24	10/25 GbE node	24	10/25 GbE node
25	10/25 GbE node	25	10/25 GbE node
26	10/25 GbE node	26	10/25 GbE node
27	10/25 GbE node	27	10/25 GbE node
28	10/25 GbE node	28	10/25 GbE node
29	10/25 GbE node	29	10/25 GbE node

Cluster switch A		Cluster switch B	
30	10/25 GbE node	30	10/25 GbE node
31	10/25 GbE node	31	10/25 GbE node
32	10/25 GbE node	32	10/25 GbE node
33	10/25 GbE node	33	10/25 GbE node
34	10/25 GbE node	34	10/25 GbE node
35	10/25 GbE node	35	10/25 GbE node
36	10/25 GbE node	36	10/25 GbE node
37	10/25 GbE node	37	10/25 GbE node
38	10/25 GbE node	38	10/25 GbE node
39	10/25 GbE node	39	10/25 GbE node
40	10/25 GbE node	40	10/25 GbE node
41	10/25 GbE node	41	10/25 GbE node
42	10/25 GbE node	42	10/25 GbE node
43	10/25 GbE node	43	10/25 GbE node
44	10/25 GbE node	44	10/25 GbE node
45	10/25 GbE node	45	10/25 GbE node
46	10/25 GbE node	46	10/25 GbE node
47	10/25 GbE node	47	10/25 GbE node
48	10/25 GbE node	48	10/25 GbE node
49	40/100 GbE node	49	40/100 GbE node
50	40/100 GbE node	50	40/100 GbE node
51	40/100 GbE node	51	40/100 GbE node

Cluster switch A		Cluster switch B	
52	40/100 GbE node	52	40/100 GbE node
53	40/100 GbE node	53	40/100 GbE node
54	40/100 GbE node	54	40/100 GbE node
55	40/100 GbE node	55	40/100 GbE node
56	40/100 GbE node	56	40/100 GbE node
57	40/100 GbE node	57	40/100 GbE node
58	40/100 GbE node	58	40/100 GbE node
59	40/100 GbE node	59	40/100 GbE node
60	40/100 GbE node	60	40/100 GbE node
61	40/100 GbE node	61	40/100 GbE node
62	40/100 GbE node	62	40/100 GbE node
63	40/100 GbE node	63	40/100 GbE node
64	40/100 GbE node	64	40/100 GbE node
65	100 GbE ISL to switch B port 65	65	100 GbE ISL to switch A port 65
66	100 GbE ISL to switch B port 66	66	100 GbE ISL to switch A port 65

Blank cabling worksheet

You can use the blank cabling worksheet to document the platforms that are supported as nodes in a cluster. The *Supported Cluster Connections* section of the *Hardware Universe* defines the cluster ports used by the platform.

Cluster switch A		Cluster switch B	
Switch port	Node/port usage	Switch port	Node/port usage
1		1	
2		2	

Cluster switch A		Cluster switch B	
3		3	
4		4	
5		5	
6		6	
7		7	
8		8	
9		9	
10		10	
11		11	
12		12	
13		13	
14		14	
15		15	
16		16	
17		17	
18		18	
19		19	
20		20	
21		21	
22		22	
23		23	
24		24	

Cluster switch A		Cluster switch B	
25		25	
26		26	
27		27	
28		28	
29		29	
30		30	
31		31	
32		32	
33		33	
34		34	
35		35	
36		36	
37		37	
38		38	
39		39	
40		40	
41		41	
42		42	
43		43	
44		44	
45		45	
46		46	

Cluster switch A		Cluster switch B	
47		47	
48		48	
49		49	
50		50	
51		51	
52		52	
53		53	
54		54	
55		55	
56		56	
57		57	
58		58	
59		59	
60		60	
61		61	
62		62	
63		63	
64		64	
65	ISL to switch B port 65	65	ISL to switch A port 65
66	ISL to switch B port 66	66	ISL to switch A port 66

Cisco Nexus 3232C cabling worksheet

If you want to document the supported platforms, you must complete the blank cabling

worksheet by using the completed sample cabling worksheet as a guide. Each switch can be configured as a single 100GbE, 40GbE port or 4 x 10GbE ports.

Sample cabling worksheet

The sample port definition on each pair of switches is as follows:

Cluster switch A		Cluster switch B	
Switch port	Node and port usage	Switch port	Node and port usage
1	4x10G/40G/100G node	1	4x10G/40G/100G node
2	4x10G/40G/100G node	2	4x10G/40G/100G node
3	4x10G/40G/100G node	3	4x10G/40G/100G node
4	4x10G/40G/100G node	4	4x10G/40G/100G node
5	4x10G/40G/100G node	5	4x10G/40G/100G node
6	4x10G/40G/100Gnode	6	4x10G/40G/100Gnode
7	4x10G/40G/100G node	7	4x10G/40G/100G node
8	4x10G/40G/100G node	8	4x10G/40G/100G node
9	4x10G/40G/100G node	9	4x10G/40G/100G node
10	4x10G/40G/100G node	10	4x10G/40G/100G node
11	4x10G/40G/100G node	11	4x10G/40G/100G node
12	4x10G/40G/100G node	12	4x10G/40G/100G node
13	4x10G/40G/100G node	13	4x10G/40G/100G node
14	4x10G/40G/100G node	14	4x10G/40G/100G node
15	4x10G/40G/100G node	15	4x10G/40G/100G node
16	4x10G/40G/100G node	16	4x10G/40G/100G node
17	4x10G/40G/100G node	17	4x10G/40G/100G node
18	4x10G/40G/100G node	18	4x10G/40G/100G node

Cluster switch A		Cluster switch B	
19	40G/100G node 19	19	40G/100G node 19
20	40G/100G node 20	20	40G/100G node 20
21	40G/100G node 21	21	40G/100G node 21
22	40G/100G node 22	22	40G/100G node 22
23	40G/100G node 23	23	40G/100G node 23
24	40G/100G node 24	24	40G/100G node 24
25 through 30	Reserved	25 through 30	Reserved
31	100G ISL to switch B port 31	31	100G ISL to switch A port 31
32	100G ISL to switch B port 32	32	100G ISL to switch A port 32

Blank cabling worksheet

You can use the blank cabling worksheet to document the platforms that are supported as nodes in a cluster. The *Supported Cluster Connections* section of the *Hardware Universe* defines the cluster ports used by the platform.

Cluster switch A		Cluster switch B	
Switch port	Node/port usage	Switch port	Node/port usage
1		1	
2		2	
3		3	
4		4	
5		5	
6		6	
7		7	
8		8	

Cluster switch A		Cluster switch B	
9		9	
10		10	
11		11	
12		12	
13		13	
14		14	
15		15	
16		16	
17		17	
18		18	
19		19	
20		20	
21		21	
22		22	
23		23	
24		24	
25 through 30	Reserved	25 through 30	Reserved
31	100G ISL to switch B port 31	31	100G ISL to switch A port 31
32	100G ISL to switch B port 32	32	100G ISL to switch A port 32

Cisco Nexus 3132Q-V cabling worksheet

If you want to document the supported platforms, you must complete the blank cabling worksheet by using the completed sample cabling worksheet as a guide. Each switch can

be configured as a single 40GbE port or 4 x 10GbE ports.

Sample cabling worksheet

The sample port definition on each pair of switches is as follows:

Cluster switch A		Cluster switch B	
Switch port	Node and port usage	Switch port	Node and port usage
1	4x10G/40G node	1	4x10G/40G node
2	4x10G/40G node	2	4x10G/40G node
3	4x10G/40G node	3	4x10G/40G node
4	4x10G/40G node	4	4x10G/40G node
5	4x10G/40G node	5	4x10G/40G node
6	4x10G/40G node	6	4x10G/40G node
7	4x10G/40G node	7	4x10G/40G node
8	4x10G/40G node	8	4x10G/40G node
9	4x10G/40G node	9	4x10G/40G node
10	4x10G/40G node	10	4x10G/40G node
11	4x10G/40G node	11	4x10G/40G node
12	4x10G/40G node	12	4x10G/40G node
13	4x10G/40G node	13	4x10G/40G node
14	4x10G/40G node	14	4x10G/40G node
15	4x10G/40G node	15	4x10G/40G node
16	4x10G/40G node	16	4x10G/40G node
17	4x10G/40G node	17	4x10G/40G node
18	4x10G/40G node	18	4x10G/40G node
19	40G node 19	19	40G node 19

Cluster switch A		Cluster switch B	
20	40G node 20	20	40G node 20
21	40G node 21	21	40G node 21
22	40G node 22	22	40G node 22
23	40G node 23	23	40G node 23
24	40G node 24	24	40G node 24
25 through 30	Reserved	25 through 30	Reserved
31	40G ISL to switch B port 31	31	40G ISL to switch A port 31
32	40G ISL to switch B port 32	32	40G ISL to switch A port 32

Blank cabling worksheet

You can use the blank cabling worksheet to document the platforms that are supported as nodes in a cluster. The *Supported Cluster Connections* section of the *Hardware Universe* defines the cluster ports used by the platform.

Cluster switch A		Cluster switch B	
Switch port	Node/port usage	Switch port	Node/port usage
1		1	
2		2	
3		3	
4		4	
5		5	
6		6	
7		7	
8		8	
9		9	

Cluster switch A		Cluster switch B	
10		10	
11		11	
12		12	
13		13	
14		14	
15		15	
16		16	
17		17	
18		18	
19		19	
20		20	
21		21	
22		22	
23		23	
24		24	
25 through 30	Reserved	25 through 30	Reserved
31	40G ISL to switch B port 31	31	40G ISL to switch A port 31
32	40G ISL to switch B port 32	32	40G ISL to switch A port 32

Cisco Nexus 5596UP and 5596T cabling worksheet

If you want to document the supported platforms, you must complete the blank cabling worksheet by using the completed sample cabling worksheet as a guide.

Sample cabling worksheet

Some platforms support more than one 10GbE cluster port connection per cluster interconnect switch. To support additional cluster connections, you can use ports 25 through 40, as well as ports 49 through 80 when expansion modules are installed.

The sample port definition on each pair of switches is as follows:

Cluster switch A		Cluster switch B	
Switch port	Node and port usage	Switch port	Node and port usage
1	Node port 1	1	Node port 1
2	Node port 2	2	Node port 2
3	Node port 3	3	Node port 3
4	Node port 4	4	Node port 4
5	Node port 5	5	Node port 5
6	Node port 6	6	Node port 6
7	Node port 7	7	Node port 7
8	Node port 8	8	Node port 8
9	Node port 9	9	Node port 9
10	Node port 10	10	Node port 10
11	Node port 11	11	Node port 11
12	Node port 12	12	Node port 12
13	Node port 13	13	Node port 13
14	Node port 14	14	Node port 14
15	Node port 15	15	Node port 15
16	Node port 16	16	Node port 16
17	Node port 17	17	Node port 17
18	Node port 18	18	Node port 18

Cluster switch A		Cluster switch B	
19	Node port 19	19	Node port 19
20	Node port 20	20	Node port 20
21	Node port 21	21	Node port 21
22	Node port 22	22	Node port 22
23	Node port 23	23	Node port 23
24	Node port 24	24	Node port 24
25 through 40	Reserved	25 through 40	Reserved
41	ISL to switch B port 41	41	ISL to switch A port 41
42	ISL to switch B port 42	42	ISL to switch A port 42
43	ISL to switch B port 43	43	ISL to switch A port 43
44	ISL to switch B port 44	44	ISL to switch A port 44
45	ISL to switch B port 45	45	ISL to switch A port 45
46	ISL to switch B port 46	46	ISL to switch A port 46
47	ISL to switch B port 47	47	ISL to switch A port 47
48	ISL to switch B port 48	48	ISL to switch A port 48

Blank cabling worksheet

You can use the blank cabling worksheet to document the platforms that are supported as nodes in a cluster. The *Supported Cluster Connections* section of the *Hardware Universe* defines the cluster ports used by the platform.



Switch ports 1 through 24 function as 10 GbE ports. Switch ports 41 through 48 are reserved for Inter-Switch Links (ISLs).

Cluster switch A		Cluster switch B	
Switch port	Node/port usage	Switch port	Node/port usage
1		1	

Cluster switch A		Cluster switch B	
2		2	
3		3	
4		4	
5		5	
6		6	
7		7	
8		8	
9		9	
10		10	
11		11	
12		12	
13		13	
14		14	
15		15	
16		16	
17		17	
18		18	
19		19	
20		20	
21		21	
22		22	
23		23	

Cluster switch A		Cluster switch B	
24		24	
25 through 40	Reserved	25 through 40	Reserved
41	ISL to switch B port 41	41	ISL to switch A port 41
42	ISL to switch B port 42	42	ISL to switch A port 42
43	ISL to switch B port 43	43	ISL to switch A port 43
44	ISL to switch B port 44	44	ISL to switch A port 44
45	ISL to switch B port 45	45	ISL to switch A port 45
46	ISL to switch B port 46	46	ISL to switch A port 46
47	ISL to switch B port 47	47	ISL to switch A port 47
48	ISL to switch B port 48	48	ISL to switch A port 48

Install NX-OS software and RCFs on Cisco Nexus 3132Q-V cluster switches

The Cisco NX-OS software and reference configuration files (RCFs) must be installed on Cisco Nexus 3132Q-V cluster switches.

Before you begin

The following conditions must exist before you install the NX-OS software and Reference Configurations Files (RCFs) on the cluster switch:

- The cluster must be fully functioning (there should be no errors in the logs or similar issues).
- You must have checked or set your desired boot configuration in the RCF to reflect the desired boot images if you are installing only NX-OS and keeping your current RCF version.
- If you need to change the boot configuration to reflect the current boot images, you must do so before reapplying the RCF so that the correct version is instantiated on future reboots.
- You must have a console connection to the switch, required when installing the RCF.
- You must have consulted the switch compatibility table on the [Cisco Ethernet switch](#) page for the supported ONTAP, NX-OS, and RCF versions.
- There can be command dependencies between the command syntax in the RCF and that found in versions of NX-OS.
- You must have referred to the appropriate software and upgrade guides available on the Cisco web site for complete documentation on the Cisco switch upgrade and downgrade procedures on [Cisco Nexus 3000 Series Switches](#).

- You must have the current RCF.

About this task

The examples in this procedure use two nodes. These nodes use two 10GbE cluster interconnect ports e0a and e0b.

See the [Hardware Universe](#) to verify the correct cluster ports on your platforms.



The command outputs might vary depending on different releases of ONTAP.

The examples in this procedure use the following switch and node nomenclature:

- The names of the two Cisco switches are `cs1` and `cs2`.
- The node names are `cluster1-01` and `cluster1-02`.
- The cluster LIF names are `cluster1-01_clus1` and `cluster1-01_clus2` for `cluster1-01` and `cluster1-02_clus1` and `cluster1-02_clus2` for `cluster1-02`.
- The `cluster1::*>` prompt indicates the name of the cluster.



The procedure requires the use of both ONTAP commands and Cisco Nexus 3000 Series Switches commands; ONTAP commands are used unless otherwise indicated.

Steps

1. If AutoSupport is enabled on this cluster, suppress automatic case creation by invoking an AutoSupport message:

```
system node autosupport invoke -node * -type all -message MAINT=x h
```

where *x* is the duration of the maintenance window in hours.



The AutoSupport message notifies technical support of this maintenance task so that automatic case creation is suppressed during the maintenance window.

2. Change the privilege level to advanced, entering *y* when prompted to continue:

```
set -privilege advanced
```

The advanced prompt (**>*) appears.

3. Display how many cluster interconnect interfaces are configured in each node for each cluster interconnect switch:

```
network device-discovery show -protocol cdp
```

```
cluster1::*> network device-discovery show -protocol cdp
```

Node/ Protocol	Local Port	Discovered Device (LLDP: ChassisID)	Interface	Platform
cluster1-02/cdp	e0a	cs1	Eth1/2	N3K-
C3132Q-V	e0b	cs2	Eth1/2	N3K-
C3132Q-V				
cluster1-01/cdp	e0a	cs1	Eth1/1	N3K-
C3132Q-V	e0b	cs2	Eth1/1	N3K-
C3132Q-V				

4 entries were displayed.

4. Check the administrative or operational status of each cluster interface.

a. Display the network port attributes:

```
network port show -ip-space Cluster
```

```
cluster1::*> network port show -ip-space Cluster
```

```
Node: cluster1-02
```

Port	IPspace	Broadcast Domain	Link	MTU	Speed (Mbps) Admin/Oper	Health Status
e0a	Cluster	Cluster	up	9000	auto/10000	healthy
e0b	Cluster	Cluster	up	9000	auto/10000	healthy

```
Node: cluster1-01
```

Port	IPspace	Broadcast Domain	Link	MTU	Speed (Mbps) Admin/Oper	Health Status
e0a	Cluster	Cluster	up	9000	auto/10000	healthy
e0b	Cluster	Cluster	up	9000	auto/10000	healthy

4 entries were displayed.

b. Display information about the LIFs:

```
network interface show -vserver Cluster
```

```
cluster1::*> network interface show -vserver Cluster
```

Current Is	Logical	Status	Network	Current
Vserver	Interface	Admin/Oper	Address/Mask	Node
Port	Home			

Cluster				
	cluster1-01_clus1	up/up	169.254.209.69/16	
cluster1-01	e0a true			
	cluster1-01_clus2	up/up	169.254.49.125/16	
cluster1-01	e0b true			
	cluster1-02_clus1	up/up	169.254.47.194/16	
cluster1-02	e0a true			
	cluster1-02_clus2	up/up	169.254.19.183/16	
cluster1-02	e0b true			

4 entries were displayed.

5. Ping the remote cluster LIFs:

```
cluster ping-cluster -node node-name
```

```

cluster1::*> cluster ping-cluster -node cluster1-02
Host is cluster1-02
Getting addresses from network interface table...
Cluster cluster1-01_clus1 169.254.209.69 cluster1-01 e0a
Cluster cluster1-01_clus2 169.254.49.125 cluster1-01 e0b
Cluster cluster1-02_clus1 169.254.47.194 cluster1-02 e0a
Cluster cluster1-02_clus2 169.254.19.183 cluster1-02 e0b
Local = 169.254.47.194 169.254.19.183
Remote = 169.254.209.69 169.254.49.125
Cluster Vserver Id = 4294967293
Ping status:
....
Basic connectivity succeeds on 4 path(s)
Basic connectivity fails on 0 path(s)
.....
Detected 9000 byte MTU on 4 path(s):
    Local 169.254.19.183 to Remote 169.254.209.69
    Local 169.254.19.183 to Remote 169.254.49.125
    Local 169.254.47.194 to Remote 169.254.209.69
    Local 169.254.47.194 to Remote 169.254.49.125
Larger than PMTU communication succeeds on 4 path(s)
RPC status:
2 paths up, 0 paths down (tcp check)
2 paths up, 0 paths down (udp check)

```

6. Verify that the auto-revert command is enabled on all cluster LIFs:

```
network interface show -vserver Cluster -fields auto-revert
```

```

cluster1::*> network interface show -vserver Cluster -fields auto-revert

          Logical
Vserver  Interface          Auto-revert
-----  -
Cluster
          cluster1-01_clus1  true
          cluster1-01_clus2  true
          cluster1-02_clus1  true
          cluster1-02_clus2  true
4 entries were displayed.

```

7. For ONTAP 9.8 and later, enable the Ethernet switch health monitor log collection feature for collecting switch-related log files by using the commands:

```
system switch ethernet log setup-password
```



```
system switch ethernet log enable-collection
```

```
cluster1::*> system switch ethernet log setup-password
Enter the switch name: <return>
The switch name entered is not recognized.
Choose from the following list:
cs1
cs2

cluster1::*> system switch ethernet log setup-password

Enter the switch name: cs1
RSA key fingerprint is e5:8b:c6:dc:e2:18:18:09:36:63:d9:63:dd:03:d9:cc
Do you want to continue? {y|n}::[n] y

Enter the password: <enter switch password>
Enter the password again: <enter switch password>

cluster1::*> system switch ethernet log setup-password

Enter the switch name: cs2
RSA key fingerprint is 57:49:86:a1:b9:80:6a:61:9a:86:8e:3c:e3:b7:1f:b1
Do you want to continue? {y|n}:: [n] y

Enter the password: <enter switch password>
Enter the password again: <enter switch password>

cluster1::*> system switch ethernet log enable-collection

Do you want to enable cluster log collection for all nodes in the
cluster?
{y|n}: [n] y

Enabling cluster switch log collection.

cluster1::*>
```



If any of these commands return an error, contact NetApp support.

8. For ONTAP releases 9.5P16, 9.6P12, and 9.7P10 and later patch releases, enable the Ethernet switch health monitor log collection feature for collecting switch-related log files by using the commands:

```
system cluster-switch log setup-password
```

```
system cluster-switch log enable-collection
```

```

cluster1::*> system cluster-switch log setup-password
Enter the switch name: <return>
The switch name entered is not recognized.
Choose from the following list:
cs1
cs2

cluster1::*> system cluster-switch log setup-password

Enter the switch name: cs1
RSA key fingerprint is e5:8b:c6:dc:e2:18:18:09:36:63:d9:63:dd:03:d9:cc
Do you want to continue? {y|n}::[n] y

Enter the password: <enter switch password>
Enter the password again: <enter switch password>

cluster1::*> system cluster-switch log setup-password

Enter the switch name: cs2
RSA key fingerprint is 57:49:86:a1:b9:80:6a:61:9a:86:8e:3c:e3:b7:1f:b1
Do you want to continue? {y|n}:: [n] y

Enter the password: <enter switch password>
Enter the password again: <enter switch password>

cluster1::*> system cluster-switch log enable-collection

Do you want to enable cluster log collection for all nodes in the
cluster?
{y|n}: [n] y

Enabling cluster switch log collection.

cluster1::*>

```



If any of these commands return an error, contact NetApp support.

Install the NX-OS software

You can use this procedure to install the NX-OS software on the Nexus 3132Q-V cluster switch.

Steps

1. Connect the cluster switch to the management network.

2. Use the `ping` command to verify connectivity to the server hosting the NX-OS software and the RCF.

This example verifies that the switch can reach the server at IP address 172.19.2.1:

```
cs2# ping 172.19.2.1
Pinging 172.19.2.1 with 0 bytes of data:

Reply From 172.19.2.1: icmp_seq = 0. time= 5910 usec.
```

3. Copy the NX-OS software to the Nexus 3132Q-V switch.

```
cs2# copy sftp: bootflash: vrf management
Enter source filename: /code/nxos.9.3.4.bin
Enter hostname for the sftp server: 172.19.2.1
Enter username: user1

Outbound-ReKey for 172.19.2.1:22
Inbound-ReKey for 172.19.2.1:22
user1@172.19.2.1's password: xxxxxxxx
sftp> progress
Progress meter enabled
sftp> get /code/nxos.9.3.4.bin /bootflash/nxos.9.3.4.bin
/code/nxos.9.3.4.bin 100% 1261MB 9.3MB/s 02:15
sftp> exit
Copy complete, now saving to disk (please wait)...
Copy complete.
```

4. Verify the running version of the NX-OS software:

```
cs2# show version
Cisco Nexus Operating System (NX-OS) Software
TAC support: http://www.cisco.com/tac
Copyright (C) 2002-2020, Cisco and/or its affiliates.
All rights reserved.
The copyrights to certain works contained in this software are
owned by other third parties and used and distributed under their own
licenses, such as open source. This software is provided "as is," and
unless
otherwise stated, there is no warranty, express or implied, including
but not
limited to warranties of merchantability and fitness for a particular
purpose.
Certain components of this software are licensed under
the GNU General Public License (GPL) version 2.0 or
```

```
GNU General Public License (GPL) version 3.0 or the GNU
Lesser General Public License (LGPL) Version 2.1 or
Lesser General Public License (LGPL) Version 2.0.
A copy of each such license is available at
http://www.opensource.org/licenses/gpl-2.0.php and
http://opensource.org/licenses/gpl-3.0.html and
http://www.opensource.org/licenses/lgpl-2.1.php and
http://www.gnu.org/licenses/old-licenses/library.txt.
```

Software

```
BIOS: version 04.25
NXOS: version 9.3(3)
BIOS compile time: 01/28/2020
NXOS image file is: bootflash:///nxos.9.3.3.bin
NXOS compile time: 12/22/2019 2:00:00 [12/22/2019
14:00:37]
```

Hardware

```
cisco Nexus 3132QV Chassis (Nexus 9000 Series)
Intel(R) Core(TM) i3- CPU @ 2.50GHz with 16399900 kB of memory.
Processor Board ID FOxxxxxxx23
```

```
Device name: cs2
bootflash: 15137792 kB
usb1: 0 kB (expansion flash)
```

```
Kernel uptime is 79 day(s), 10 hour(s), 23 minute(s), 53 second(s)
```

```
Last reset at 663500 usecs after Mon Nov 2 10:50:33 2020
Reason: Reset Requested by CLI command reload
System version: 9.3(3)
Service:
```

plugin

```
Core Plugin, Ethernet Plugin
```

```
Active Package(s):
cs2#
```

5. Install the NX-OS image.

Installing the image file causes it to be loaded every time the switch is rebooted.

```
cs2# install all nxos bootflash:nxos.9.3.4.bin
Installer will perform compatibility check first. Please wait.
Installer is forced disruptive
```

Verifying image bootflash:/nxos.9.3.4.bin for boot variable "nxos".

[] 100% -- SUCCESS

Verifying image type.

[] 100% -- SUCCESS

Preparing "nxos" version info using image bootflash:/nxos.9.3.4.bin.

[] 100% -- SUCCESS

Preparing "bios" version info using image bootflash:/nxos.9.3.4.bin.

[] 100% -- SUCCESS

Performing module support checks.

[] 100% -- SUCCESS

Notifying services about system upgrade.

[] 100% -- SUCCESS

Compatibility check is done:

Module	bootable	Impact	Install-type	Reason
1	yes	disruptive	reset	default

upgrade is not hitless

Images will be upgraded according to following table:

Module Version	Image Upg-Required	Running-Version(pri:alt)	New-
1	nxos	9.3(3)	9.3(4)
1	bios	v04.25(01/28/2020):v04.25(10/18/2016)	
v04.25(01/28/2020)	no		

Switch will be reloaded for disruptive upgrade.

Do you want to continue with the installation (y/n)? [n] **y**

Install is in progress, please wait.

Performing runtime checks.

[] 100% -- SUCCESS

Setting boot variables.

```
[ ] 100% -- SUCCESS
```

```
Performing configuration copy.
```

```
[ ] 100% -- SUCCESS
```

```
Module 1: Refreshing compact flash and upgrading bios/loader/bootrom.
```

```
Warning: please do not remove or power off the module at this time.
```

```
[ ] 100% -- SUCCESS
```

```
Finishing the upgrade, switch will reboot in 10 seconds.
```

```
cs2#
```

6. Verify the new version of NX-OS software after the switch has rebooted:

```
show version
```

```
cs2# show version
```

```
Cisco Nexus Operating System (NX-OS) Software
```

```
TAC support: http://www.cisco.com/tac
```

```
Copyright (C) 2002-2020, Cisco and/or its affiliates.
```

```
All rights reserved.
```

```
The copyrights to certain works contained in this software are  
owned by other third parties and used and distributed under their own  
licenses, such as open source. This software is provided "as is," and  
unless
```

```
otherwise stated, there is no warranty, express or implied, including  
but not
```

```
limited to warranties of merchantability and fitness for a particular  
purpose.
```

```
Certain components of this software are licensed under  
the GNU General Public License (GPL) version 2.0 or  
GNU General Public License (GPL) version 3.0 or the GNU  
Lesser General Public License (LGPL) Version 2.1 or  
Lesser General Public License (LGPL) Version 2.0.
```

```
A copy of each such license is available at  
http://www.opensource.org/licenses/gpl-2.0.php and  
http://opensource.org/licenses/gpl-3.0.html and  
http://www.opensource.org/licenses/lgpl-2.1.php and  
http://www.gnu.org/licenses/old-licenses/library.txt.
```

```
Software
```

```
  BIOS: version 04.25
```

```
NXOS: version 9.3(4)
```

```
  BIOS compile time: 05/22/2019
```

```
  NXOS image file is: bootflash:///nxos.9.3.4.bin
```

```
NXOS compile time: 4/28/2020 21:00:00 [04/29/2020 06:28:31]
```

Hardware

```
cisco Nexus 3132QV Chassis (Nexus 9000 Series)
Intel(R) Core(TM) i3- CPU @ 2.50GHz with 16399900 kB of memory.
Processor Board ID FOxxxxxxxx23
```

```
Device name: cs2
bootflash: 15137792 kB
usb1: 0 kB (expansion flash)
```

```
Kernel uptime is 79 day(s), 10 hour(s), 23 minute(s), 53 second(s)
```

```
Last reset at 663500 usecs after Mon Nov 2 10:50:33 2020
Reason: Reset Requested by CLI command reload
System version: 9.3(4)
Service:
```

```
plugin
Core Plugin, Ethernet Plugin
```

```
Active Package(s):
```

```
cs2#
```

Install the Reference Configuration File (RCF)

You can install the RCF after setting up the Nexus 3132Q-V switch for the first time. You can also use this procedure to upgrade your RCF version.

About this task

The examples in this procedure use the following switch and node nomenclature:

- The names of the two Cisco switches are `cs1` and `cs2`.
- The node names are `cluster1-01`, `cluster1-02`, `cluster1-03`, and `cluster1-04`.
- The cluster LIF names are `cluster1-01_clus1`, `cluster1-01_clus2`, `cluster1-02_clus1`, `cluster1-02_clus2`, `cluster1-03_clus1`, `cluster1-03_clus2`, `cluster1-04_clus1`, and `cluster1-04_clus2`.
- The `cluster1::*>` prompt indicates the name of the cluster.



The procedure requires the use of both ONTAP commands and Cisco Nexus 3000 Series Switches commands; ONTAP commands are used unless otherwise indicated.

Steps

1. Display the cluster ports on each node that are connected to the cluster switches:

```
network device-discovery show
```

```
cluster1::*> network device-discovery show
Node/      Local  Discovered
Protocol   Port   Device (LLDP: ChassisID)  Interface      Platform
-----
-----
cluster1-01/cdp
           e0a    cs1                      Ethernet1/7    N3K-
C3132Q-V
           e0d    cs2                      Ethernet1/7    N3K-
C3132Q-V
cluster1-02/cdp
           e0a    cs1                      Ethernet1/8    N3K-
C3132Q-V
           e0d    cs2                      Ethernet1/8    N3K-
C3132Q-V
cluster1-03/cdp
           e0a    cs1                      Ethernet1/1/1  N3K-
C3132Q-V
           e0b    cs2                      Ethernet1/1/1  N3K-
C3132Q-V
cluster1-04/cdp
           e0a    cs1                      Ethernet1/1/2  N3K-
C3132Q-V
           e0b    cs2                      Ethernet1/1/2  N3K-
C3132Q-V
cluster1::*>
```

2. Check the administrative and operational status of each cluster port.

a. Verify that all the cluster ports are up with a healthy status:

```
network port show -role cluster
```

```
cluster1::*> network port show -role cluster

Node: cluster1-01

Ignore

Health                                     Speed(Mbps) Health
Port      IPspace      Broadcast Domain Link MTU   Admin/Oper  Status
Status
```



```

-----
e0a      Cluster      Cluster      up    9000  auto/100000
healthy false
e0d      Cluster      Cluster      up    9000  auto/100000
healthy false

```

Node: cluster1-02

Ignore

```

                                          Speed(Mbps) Health
Health
Port      IPspace      Broadcast Domain Link MTU  Admin/Oper  Status
Status
-----

```

```

-----
e0a      Cluster      Cluster      up    9000  auto/100000
healthy false
e0d      Cluster      Cluster      up    9000  auto/100000
healthy false

```

8 entries were displayed.

Node: cluster1-03

Ignore

```

                                          Speed(Mbps) Health
Health
Port      IPspace      Broadcast Domain Link MTU  Admin/Oper  Status
Status
-----

```

```

-----
e0a      Cluster      Cluster      up    9000  auto/10000 healthy
false
e0b      Cluster      Cluster      up    9000  auto/10000 healthy
false

```

Node: cluster1-04

Ignore

```

                                          Speed(Mbps) Health
Health
Port      IPspace      Broadcast Domain Link MTU  Admin/Oper  Status
Status
-----

```

```

-----
e0a      Cluster      Cluster      up    9000  auto/10000 healthy

```

```

false
e0b      Cluster      Cluster      up   9000   auto/10000 healthy
false
cluster1::*>

```

b. Verify that all the cluster interfaces (LIFs) are on the home port:

```
network interface show -role cluster
```

```

cluster1::*> network interface show -role cluster
          Logical          Status      Network          Current
Current Is
Vserver   Interface          Admin/Oper Address/Mask      Node
Port      Home
-----
-----
Cluster
01  e0a      cluster1-01_clus1  up/up      169.254.3.4/23   cluster1-
          true
          cluster1-01_clus2  up/up      169.254.3.5/23   cluster1-
          true
01  e0d      cluster1-02_clus1  up/up      169.254.3.8/23   cluster1-
          true
02  e0a      cluster1-02_clus2  up/up      169.254.3.9/23   cluster1-
          true
02  e0d      cluster1-03_clus1  up/up      169.254.1.3/23   cluster1-
          true
03  e0a      cluster1-03_clus2  up/up      169.254.1.1/23   cluster1-
          true
03  e0b      cluster1-04_clus1  up/up      169.254.1.6/23   cluster1-
          true
04  e0a      cluster1-04_clus2  up/up      169.254.1.7/23   cluster1-
          true
04  e0b      true
8 entries were displayed.
cluster1::*>

```

c. Verify that the cluster displays information for both cluster switches:

```
system cluster-switch show -is-monitoring-enabled-operational true
```

```

cluster1::*> system cluster-switch show -is-monitoring-enabled
-operational true
Switch                               Type                               Address                             Model
-----
cs1                                   cluster-network                    10.0.0.1
NX3132QV
  Serial Number: FOXXXXXXXXGS
  Is Monitored: true
  Reason: None
  Software Version: Cisco Nexus Operating System (NX-OS) Software,
Version
                        9.3(4)
  Version Source: CDP

cs2                                   cluster-network                    10.0.0.2
NX3132QV
  Serial Number: FOXXXXXXXXGD
  Is Monitored: true
  Reason: None
  Software Version: Cisco Nexus Operating System (NX-OS) Software,
Version
                        9.3(4)
  Version Source: CDP

2 entries were displayed.

```

3. Disable auto-revert on the cluster LIFs.

```

cluster1::*> network interface modify -vserver Cluster -lif \* -auto
-revert false

```

4. On cluster switch cs2, shut down the ports connected to the cluster ports of the nodes.

```

cs2(config)# interface eth1/1/1-2,eth1/7-8
cs2(config-if-range)# shutdown

```

5. Verify that the cluster ports have migrated to the ports hosted on cluster switch cs1. This might take a few seconds.

```

network interface show -role cluster

```

```

cluster1::*> network interface show -role cluster
          Logical          Status      Network          Current
Current Is
Vserver   Interface          Admin/Oper Address/Mask      Node
Port     Home
-----
-----
Cluster
e0a      true      cluster1-01_clus1 up/up      169.254.3.4/23   cluster1-01
e0a      false     cluster1-01_clus2 up/up      169.254.3.5/23   cluster1-01
e0a      true      cluster1-02_clus1 up/up      169.254.3.8/23   cluster1-02
e0a      false     cluster1-02_clus2 up/up      169.254.3.9/23   cluster1-02
e0a      true      cluster1-03_clus1 up/up      169.254.1.3/23   cluster1-03
e0a      false     cluster1-03_clus2 up/up      169.254.1.1/23   cluster1-03
e0a      true      cluster1-04_clus1 up/up      169.254.1.6/23   cluster1-04
e0a      false     cluster1-04_clus2 up/up      169.254.1.7/23   cluster1-04
8 entries were displayed.
cluster1::*>

```

6. Verify that the cluster is healthy:

```
cluster show
```

```

cluster1::*> cluster show
Node          Health  Eligibility  Epsilon
-----
cluster1-01   true    true         false
cluster1-02   true    true         false
cluster1-03   true    true         true
cluster1-04   true    true         false
4 entries were displayed.
cluster1::*>

```

7. Clean the configuration on switch cs2 and perform a basic setup.

- a. Clean the configuration.



This step requires a console connection to the switch.

```
cs2# write erase
Warning: This command will erase the startup-configuration.
Do you wish to proceed anyway? (y/n) [n] y
cs2# reload
This command will reboot the system. (y/n)? [n] y
cs2#
```

b. Perform a basic setup of the switch.

8. Copy the RCF to the bootflash of switch cs2 using one of the following transfer protocols: FTP, TFTP, SFTP, or SCP. For more information on Cisco commands, see the appropriate guide in the [Cisco Nexus 3000 Series NX-OS Command Reference](#) guides.

This example shows TFTP being used to copy an RCF to the bootflash on switch cs2:

```
cs2# copy tftp: bootflash: vrf management
Enter source filename: Nexus_3132QV_RCF_v1.6-Cluster-HA-Breakout.txt
Enter hostname for the tftp server: 172.22.201.50
Trying to connect to tftp server.....Connection to Server Established.
TFTP get operation was successful
Copy complete, now saving to disk (please wait)...
```

9. Apply the RCF previously downloaded to the bootflash.

For more information on Cisco commands, see the appropriate guide in the [Cisco Nexus 3000 Series NX-OS Command Reference](#) guides.

This example shows the RCF file `Nexus_3132QV_RCF_v1.6-Cluster-HA-Breakout.txt` being installed on switch cs2:

```
cs2# copy Nexus_3132QV_RCF_v1.6-Cluster-HA-Breakout.txt running-config
echo-commands
```

10. Examine the banner output from the `show banner motd` command. You must read and follow the instructions under **Important Notes** to ensure the proper configuration and operation of the switch.

```
cs2# show banner motd
```

```
*****
*****
* NetApp Reference Configuration File (RCF)
*
* Switch   : Cisco Nexus 3132Q-V
* Filename : Nexus_3132QV_RCF_v1.6-Cluster-HA-Breakout.txt
* Date     : Nov-02-2020
* Version  : v1.6
*
* Port Usage : Breakout configuration
* Ports 1- 6: Breakout mode (4x10GbE) Intra-Cluster Ports, int e1/1/1-
4,
* e1/2/1-4, e1/3/1-4,int e1/4/1-4, e1/5/1-4, e1/6/1-4
* Ports 7-30: 40GbE Intra-Cluster/HA Ports, int e1/7-30
* Ports 31-32: Intra-Cluster ISL Ports, int e1/31-32
*
* IMPORTANT NOTES
* - Load Nexus_3132QV_RCF_v1.6-Cluster-HA.txt for non breakout config
*
* - This RCF utilizes QoS and requires specific TCAM configuration,
requiring
*   cluster switch to be rebooted before the cluster becomes
operational.
*
* - Perform the following steps to ensure proper RCF installation:
*
*   (1) Apply RCF, expect following messages:
*       - Please save config and reload the system...
*       - Edge port type (portfast) should only be enabled on ports...
*       - TCAM region is not configured for feature QoS class IPv4...
*
*   (2) Save running-configuration and reboot Cluster Switch
*
*****
*****
```

11. Verify that the RCF file is the correct newer version:

```
show running-config
```

When you check the output to verify you have the correct RCF, make sure that the following information is correct:

- The RCF banner
- The node and port settings
- Customizations The output varies according to your site configuration. Check the port settings and refer to the release notes for any changes specific to the RCF that you have installed.

12. After you verify the RCF versions and switch settings are correct, copy the running-config file to the startup-config file.

For more information on Cisco commands, see the appropriate guide in the [Cisco Nexus 3000 Series NX-OS Command Reference](#) guides.

```
cs2# copy running-config startup-config
[#####] 100% Copy complete
```

13. Reboot switch cs2. You can ignore the "cluster ports down" events reported on the nodes while the switch reboots.

```
cs2# reload
This command will reboot the system. (y/n)? [n] y
```

14. Apply the same RCF and save the running configuration for a second time.

```
cs2# copy Nexus_3132QV_RCF_v1.6-Cluster-HA-Breakout.txt running-config
echo-commands
cs2# copy running-config startup-config
[#####] 100% Copy complete
```

15. Verify the health of cluster ports on the cluster.

a. Verify that e0d ports are up and healthy across all nodes in the cluster:

```
network port show -role cluster
```

```
cluster1::*> network port show -role cluster

Node: cluster1-01

Ignore

Health
Port      IPspace      Broadcast Domain Link MTU  Admin/Oper  Status
Status
-----
e0a      Cluster      Cluster      up    9000  auto/10000  healthy
```

```

false
e0b      Cluster      Cluster      up    9000  auto/10000 healthy
false

Node: cluster1-02

Ignore

Health
Port      IPspace      Broadcast Domain Link MTU  Admin/Oper  Status
Speed(Mbps) Health
-----
e0a      Cluster      Cluster      up    9000  auto/10000 healthy
false
e0b      Cluster      Cluster      up    9000  auto/10000 healthy
false

Node: cluster1-03

Ignore

Health
Port      IPspace      Broadcast Domain Link MTU  Admin/Oper  Status
Speed(Mbps) Health
-----
e0a      Cluster      Cluster      up    9000  auto/100000
healthy false
e0d      Cluster      Cluster      up    9000  auto/100000
healthy false

Node: cluster1-04

Ignore

Health
Port      IPspace      Broadcast Domain Link MTU  Admin/Oper  Status
Speed(Mbps) Health
-----
e0a      Cluster      Cluster      up    9000  auto/100000
healthy false
e0d      Cluster      Cluster      up    9000  auto/100000
healthy false
8 entries were displayed.

```

- b. Verify the switch health from the cluster (this might not show switch cs2, since LIFs are not homed on e0d).

```

cluster1::*> network device-discovery show -protocol cdp
Node/          Local  Discovered
Protocol      Port   Device (LLDP: ChassisID)  Interface
Platform
-----
-----
cluster1-01/cdp
              e0a    cs1                      Ethernet1/7      N3K-
C3132Q-V
              e0d    cs2                      Ethernet1/7      N3K-
C3132Q-V
cluster01-2/cdp
              e0a    cs1                      Ethernet1/8      N3K-
C3132Q-V
              e0d    cs2                      Ethernet1/8      N3K-
C3132Q-V
cluster01-3/cdp
              e0a    cs1                      Ethernet1/1/1    N3K-
C3132Q-V
              e0b    cs2                      Ethernet1/1/1    N3K-
C3132Q-V
cluster1-04/cdp
              e0a    cs1                      Ethernet1/1/2    N3K-
C3132Q-V
              e0b    cs2                      Ethernet1/1/2    N3K-
C3132Q-V

cluster1::*> system cluster-switch show -is-monitoring-enabled
-operational true
Switch                Type                Address             Model
-----
cs1                    cluster-network    10.233.205.90     N3K-
C3132Q-V
    Serial Number: FOXXXXXXXXGD
    Is Monitored: true
    Reason: None
    Software Version: Cisco Nexus Operating System (NX-OS) Software,
Version
                        9.3(4)
    Version Source: CDP

cs2                    cluster-network    10.233.205.91     N3K-
C3132Q-V

```

```
Serial Number: FOXXXXXXXXGS
  Is Monitored: true
    Reason: None
Software Version: Cisco Nexus Operating System (NX-OS) Software,
Version
                9.3(4)
Version Source: CDP

2 entries were displayed.
```

You might observe the following output on the cs1 switch console depending on the RCF version previously loaded on the switch:



```
2020 Nov 17 16:07:18 cs1 %$ VDC-1 %$ %STP-2-
UNBLOCK_CONSIST_PORT: Unblocking port port-channell on
VLAN0092. Port consistency restored.
2020 Nov 17 16:07:23 cs1 %$ VDC-1 %$ %STP-2-BLOCK_PVID_PEER:
Blocking port-channell on VLAN0001. Inconsistent peer vlan.
2020 Nov 17 16:07:23 cs1 %$ VDC-1 %$ %STP-2-BLOCK_PVID_LOCAL:
Blocking port-channell on VLAN0092. Inconsistent local vlan.
```

16. On cluster switch cs1, shut down the ports connected to the cluster ports of the nodes.

The following example uses the interface example output from step 1:

```
cs1(config)# interface eth1/1/1-2,eth1/7-8
cs1(config-if-range)# shutdown
```

17. Verify that the cluster LIFs have migrated to the ports hosted on switch cs2. This might take a few seconds.

```
network interface show -role cluster
```

```

cluster1::*> network interface show -role cluster
          Logical          Status      Network          Current
Current Is
Vserver   Interface              Admin/Oper  Address/Mask     Node
Port      Home
-----
-----
Cluster
e0d       cluster1-01_clus1  up/up      169.254.3.4/23   cluster1-01
false
e0d       cluster1-01_clus2  up/up      169.254.3.5/23   cluster1-01
true
e0d       cluster1-02_clus1  up/up      169.254.3.8/23   cluster1-02
false
e0d       cluster1-02_clus2  up/up      169.254.3.9/23   cluster1-02
true
e0b       cluster1-03_clus1  up/up      169.254.1.3/23   cluster1-03
false
e0b       cluster1-03_clus2  up/up      169.254.1.1/23   cluster1-03
true
e0b       cluster1-04_clus1  up/up      169.254.1.6/23   cluster1-04
false
e0b       cluster1-04_clus2  up/up      169.254.1.7/23   cluster1-04
true
8 entries were displayed.
cluster1::*>

```

18. Verify that the cluster is healthy:

```
cluster show
```

```

cluster1::*> cluster show
Node          Health  Eligibility  Epsilon
-----
cluster1-01   true    true         false
cluster1-02   true    true         false
cluster1-03   true    true         true
cluster1-04   true    true         false
4 entries were displayed.
cluster1::*>

```

19. Repeat Steps 7 to 14 on switch cs1.

20. Enable auto-revert on the cluster LIFs.

```
cluster1::*> network interface modify -vserver Cluster -lif \* -auto
-revert True
```

21. Reboot switch cs1. You do this to trigger the cluster LIFs to revert to their home ports. You can ignore the "cluster ports down" events reported on the nodes while the switch reboots.

```
cs1# reload
This command will reboot the system. (y/n)? [n] y
```

22. Verify that the switch ports connected to the cluster ports are up.

```
cs1# show interface brief \ | grep up
.
.
Eth1/1/1      1      eth  access up      none      10G(D)
--
Eth1/1/2      1      eth  access up      none      10G(D)
--
Eth1/7        1      eth  trunk  up      none      100G(D)
--
Eth1/8        1      eth  trunk  up      none      100G(D)
--
.
.
```

23. Verify that the ISL between cs1 and cs2 is functional:

```
show port-channel summary
```

```

cs1# show port-channel summary
Flags:  D - Down          P - Up in port-channel (members)
        I - Individual    H - Hot-standby (LACP only)
        s - Suspended     r - Module-removed
        b - BFD Session Wait
        S - Switched      R - Routed
        U - Up (port-channel)
        p - Up in delay-lacp mode (member)
        M - Not in use. Min-links not met
-----
-----
Group Port-          Type      Protocol  Member Ports
  Channel
-----
-----
1      Po1(SU)       Eth       LACP      Eth1/31(P)  Eth1/32(P)
cs1#

```

24. Verify that the cluster LIFs have reverted to their home port:

```
network interface show -role cluster
```

```

cluster1::*> network interface show -role cluster
          Logical          Status      Network          Current
Current Is
Vserver   Interface          Admin/Oper Address/Mask      Node
Port      Home
-----
-----
Cluster
e0d      true      cluster1-01_clus1  up/up      169.254.3.4/23   cluster1-01
e0d      true      cluster1-01_clus2  up/up      169.254.3.5/23   cluster1-01
e0d      true      cluster1-02_clus1  up/up      169.254.3.8/23   cluster1-02
e0d      true      cluster1-02_clus2  up/up      169.254.3.9/23   cluster1-02
e0d      true      cluster1-03_clus1  up/up      169.254.1.3/23   cluster1-03
e0b      true      cluster1-03_clus2  up/up      169.254.1.1/23   cluster1-03
e0b      true      cluster1-04_clus1  up/up      169.254.1.6/23   cluster1-04
e0b      true      cluster1-04_clus2  up/up      169.254.1.7/23   cluster1-04
e0b      true
8 entries were displayed.
cluster1::*>

```

25. Verify that the cluster is healthy:

```
cluster show
```

```

cluster1::*> cluster show
Node          Health  Eligibility  Epsilon
-----
cluster1-01   true    true         false
cluster1-02   true    true         false
cluster1-03   true    true         true
cluster1-04   true    true         false
4 entries were displayed.
cluster1::*>

```

26. Ping the remote cluster interfaces to verify connectivity:

```
cluster ping-cluster -node local
```

```

cluster1::*> cluster ping-cluster -node local
Host is cluster1-03
Getting addresses from network interface table...
Cluster cluster1-03_clus1 169.254.1.3 cluster1-03 e0a
Cluster cluster1-03_clus2 169.254.1.1 cluster1-03 e0b
Cluster cluster1-04_clus1 169.254.1.6 cluster1-04 e0a
Cluster cluster1-04_clus2 169.254.1.7 cluster1-04 e0b
Cluster cluster1-01_clus1 169.254.3.4 cluster1-01 e0a
Cluster cluster1-01_clus2 169.254.3.5 cluster1-01 e0d
Cluster cluster1-02_clus1 169.254.3.8 cluster1-02 e0a
Cluster cluster1-02_clus2 169.254.3.9 cluster1-02 e0d
Local = 169.254.1.3 169.254.1.1
Remote = 169.254.1.6 169.254.1.7 169.254.3.4 169.254.3.5 169.254.3.8
169.254.3.9
Cluster Vserver Id = 4294967293
Ping status:
.....
Basic connectivity succeeds on 12 path(s)
Basic connectivity fails on 0 path(s)
.....
Detected 9000 byte MTU on 12 path(s):
    Local 169.254.1.3 to Remote 169.254.1.6
    Local 169.254.1.3 to Remote 169.254.1.7
    Local 169.254.1.3 to Remote 169.254.3.4
    Local 169.254.1.3 to Remote 169.254.3.5
    Local 169.254.1.3 to Remote 169.254.3.8
    Local 169.254.1.3 to Remote 169.254.3.9
    Local 169.254.1.1 to Remote 169.254.1.6
    Local 169.254.1.1 to Remote 169.254.1.7
    Local 169.254.1.1 to Remote 169.254.3.4
    Local 169.254.1.1 to Remote 169.254.3.5
    Local 169.254.1.1 to Remote 169.254.3.8
    Local 169.254.1.1 to Remote 169.254.3.9
Larger than PMTU communication succeeds on 12 path(s)
RPC status:
6 paths up, 0 paths down (tcp check)
6 paths up, 0 paths down (udp check)

```

Migrate to a two-node switched cluster with Cisco Nexus 3132Q-V cluster switches

You must be aware of certain configuration information, port connections and cabling requirements when you migrate to a two-node switched cluster with Cisco Nexus 3132Q-V cluster switches.

- The number of 10 GbE and 40/100 GbE ports are defined in the reference configuration files (RCFs) available on the [Cisco @ Cluster Network Switch Reference Configuration File Download](#) page.
- The cluster switches use the Inter-Switch Link (ISL) ports e1/31-32.
- The [Hardware Universe](#) contains information about supported cabling to Nexus 3132Q-V switches:
 - The nodes with 10 GbE cluster connections require QSFP optical modules with breakout fiber cables or QSFP to SFP+ copper break-out cables.
 - The nodes with 40/100 GbE cluster connections require supported QSFP/QSFP28 optical modules with fiber cables or QSFP/QSFP28 copper direct-attach cables.
 - The cluster switches use the appropriate ISL cabling: 2x QSFP28 fiber or copper direct-attach cables.
- On Nexus 3132Q-V, you can operate QSFP ports as either 40/100 Gb Ethernet or 4 x10 Gb Ethernet modes.

By default, there are 32 ports in the 40/100 Gb Ethernet mode. These 40 Gb Ethernet ports are numbered in a 2-tuple naming convention. For example, the second 40 Gb Ethernet port is numbered as 1/2. The process of changing the configuration from 40 Gb Ethernet to 10 Gb Ethernet is called *breakout* and the process of changing the configuration from 10 Gb Ethernet to 40 Gb Ethernet is called *breakin*. When you break out a 40/100 Gb Ethernet port into 10 Gb Ethernet ports, the resulting ports are numbered using a 3-tuple naming convention. For example, the breakout ports of the second 40/100 Gb Ethernet port are numbered as 1/2/1, 1/2/2, 1/2/3, 1/2/4.

- On the left side of Nexus 3132Q-V is a set of four SFP+ ports multiplexed to the first QSFP port.

By default, the RCF is structured to use the first QSFP port.

You can make four SFP+ ports active instead of a QSFP port for Nexus 3132Q-V by using the hardware profile `front portmode sfp-plus` command. Similarly, you can reset Nexus 3132Q-V to use a QSFP port instead of four SFP+ ports by using the hardware profile `front portmode qsfp` command.

- You must have configured some of the ports on Nexus 3132Q-V to run at 10 GbE or 40/100 GbE.

You can break-out the first six ports into 4x10 GbE mode by using the `interface breakout module 1 port 1-6 map 10g-4x` command. Similarly, you can regroup the first six QSFP+ ports from breakout configuration by using the `no interface breakout module 1 port 1-6 map 10g-4x` command.

- You must have done the planning, migration, and read the required documentation on 10 GbE and 40/100 GbE connectivity from nodes to Nexus 3132Q-V cluster switches.

The [Cisco Ethernet Switches](#) page has information about the ONTAP and NX-OS versions supported in this procedure.

How to migrate a two-node switched cluster with Cisco Nexus 3132Q-V cluster switches

If you have a two-node switchless cluster, you can migrate nondisruptively to a two-node switched cluster that includes Cisco Nexus 3132Q-V cluster network switches.

Before you begin

- The configurations must be properly set up and functioning.
- The nodes must be running ONTAP 9.4 or later.

- All cluster ports must be in the `up` state.
- The Cisco Nexus 3132Q-V cluster switch must be supported.
- The existing cluster network configuration must have:
 - The Nexus 3132 cluster infrastructure that is redundant and fully functional on both switches.

The latest RCF and NX-OS versions on your switches.

- Management connectivity on both switches.
- Console access to both switches.
- All cluster logical interfaces (LIFs) in the `up` state without being migrated.
- Initial customization of the switch.
- All the ISL ports enabled and cabled.

About this task

The examples in this procedure use the following switch and node nomenclature:

- Nexus 3132Q-V cluster switches, C1 and C2.
- The nodes are n1 and n2.



The examples in this procedure use two nodes, each utilizing two 40/100 GbE cluster interconnect ports e4a and e4e. The [Hardware Universe](#) has details about the cluster ports on your platforms.

- n1_clus1 is the first cluster logical interface (LIF) to be connected to cluster switch C1 for node n1.
- n1_clus2 is the first cluster LIF to be connected to cluster switch C2 for node n1.
- n2_clus1 is the first cluster LIF to be connected to cluster switch C1 for node n2.
- n2_clus2 is the second cluster LIF to be connected to cluster switch C2 for node n2.
- The number of 10 GbE and 40/100 GbE ports are defined in the reference configuration files (RCFs) available on the [Cisco @ Cluster Network Switch Reference Configuration File Download](#) page.



The procedure requires the use of both ONTAP commands and Cisco Nexus 3000 Series Switches commands; ONTAP commands are used unless otherwise indicated.

- The cluster starts with two nodes connected and functioning in a two-node switchless cluster setting.
- The first cluster port moved to C1 ([Steps 1- 20](#))
- The second cluster port moved to C2 ([Steps 21- 32](#)).
- Disable the two-node switchless cluster option ([Steps 33- 35](#))

Steps

1. If AutoSupport is enabled on this cluster, suppress automatic case creation by invoking an AutoSupport message:

```
system node autosupport invoke -node * -type all - message MAINT=xh
```

x is the duration of the maintenance window in hours.



The AutoSupport message notifies technical support of this maintenance task so that automatic case creation is suppressed during the maintenance window.

2. Determine the administrative or operational status for each cluster interface:

a. Display the network port attributes:

```
network port show
```

```
cluster::*> network port show -role cluster
(network port show)
Node: n1

Ignore

Health
Port      IPspace      Broadcast Domain Link MTU  Admin/Oper  Status
Speed (Mbps) Health
-----
-----
e4a      Cluster      Cluster      up    9000 auto/40000  -
-
e4e      Cluster      Cluster      up    9000 auto/40000  -
-

Node: n2

Ignore

Health
Port      IPspace      Broadcast Domain Link MTU  Admin/Oper  Status
Speed (Mbps) Health
-----
-----
e4a      Cluster      Cluster      up    9000 auto/40000  -
-
e4e      Cluster      Cluster      up    9000 auto/40000  -
-

4 entries were displayed.
```

b. Display information about the logical interfaces:

```
network interface show
```

```

cluster::*> network interface show -role cluster
(network interface show)

```

Current Is	Logical	Status	Network	Current
Vserver	Interface	Admin/Oper	Address/Mask	Node
Port	Home			
-----	-----	-----	-----	-----
-----	-----	-----	-----	-----
Cluster				
e4a	n1_clus1	up/up	10.10.0.1/24	n1
e4e	true			
e4a	n1_clus2	up/up	10.10.0.2/24	n1
e4e	true			
e4a	n2_clus1	up/up	10.10.0.3/24	n2
e4a	true			
e4a	n2_clus2	up/up	10.10.0.4/24	n2
e4e	true			

4 entries were displayed.

- Verify that the appropriate RCFs and image are installed on the new 3132Q-V switches as necessary for your requirements, and make any essential site customizations, such as users and passwords, network addresses, and so on.

You must prepare both switches at this time. If you need to upgrade the RCF and image software, you must follow these steps:

- Go to the [Cisco Ethernet Switches](#) page on the NetApp Support Site.
 - Note your switch and the required software versions in the table on that page.
 - Download the appropriate version of RCF.
 - Click **CONTINUE** on the **Description** page, accept the license agreement, and then follow the instructions on the **Download** page to download the RCF.
 - Download the appropriate version of the image software.
- Click **CONTINUE** on the **Description** page, accept the license agreement, and then follow the instructions on the **Download** page to download the RCF.
 - On Nexus 3132Q-V switches C1 and C2, disable all node-facing ports C1 and C2, but do not disable the ISL ports.

The following example shows ports 1 through 30 being disabled on Nexus 3132Q-V cluster switches C1 and C2 using a configuration supported in RCF

NX3132_RCF_v1.1_24p10g_26p40g.txt:

```
C1# copy running-config startup-config
[#####] 100%
Copy complete.
C1# configure
C1(config)# int e1/1/1-4,e1/2/1-4,e1/3/1-4,e1/4/1-4,e1/5/1-4,e1/6/1-
4,e1/7-30
C1(config-if-range)# shutdown
C1(config-if-range)# exit
C1(config)# exit

C2# copy running-config startup-config
[#####] 100%
Copy complete.
C2# configure
C2(config)# int e1/1/1-4,e1/2/1-4,e1/3/1-4,e1/4/1-4,e1/5/1-4,e1/6/1-
4,e1/7-30
C2(config-if-range)# shutdown
C2(config-if-range)# exit
C2(config)# exit
```

6. Connect ports 1/31 and 1/32 on C1 to the same ports on C2 using supported cabling.
7. Verify that the ISL ports are operational on C1 and C2:

```
show port-channel summary
```

```

C1# show port-channel summary
Flags: D - Down          P - Up in port-channel (members)
       I - Individual    H - Hot-standby (LACP only)
       s - Suspended     r - Module-removed
       S - Switched     R - Routed
       U - Up (port-channel)
       M - Not in use. Min-links not met

-----
-----
Group Port-          Type   Protocol  Member Ports
Channel
-----
-----
1      Po1(SU)       Eth     LACP      Eth1/31(P)  Eth1/32(P)

C2# show port-channel summary
Flags: D - Down          P - Up in port-channel (members)
       I - Individual    H - Hot-standby (LACP only)
       s - Suspended     r - Module-removed
       S - Switched     R - Routed
       U - Up (port-channel)
       M - Not in use. Min-links not met

-----
-----
Group Port-          Type   Protocol  Member Ports
Channel
-----
-----
1      Po1(SU)       Eth     LACP      Eth1/31(P)  Eth1/32(P)

```

8. Display the list of neighboring devices on the switch:

```
show cdp neighbors
```

```

C1# show cdp neighbors
Capability Codes: R - Router, T - Trans-Bridge, B - Source-Route-Bridge
                  S - Switch, H - Host, I - IGMP, r - Repeater,
                  V - VoIP-Phone, D - Remotely-Managed-Device,
                  s - Supports-STP-Dispute

Device-ID          Local Intrfce  Hldtme  Capability  Platform      Port
ID
C2                  Eth1/31        174     R S I s     N3K-C3132Q-V
Eth1/31
C2                  Eth1/32        174     R S I s     N3K-C3132Q-V
Eth1/32

Total entries displayed: 2

C2# show cdp neighbors
Capability Codes: R - Router, T - Trans-Bridge, B - Source-Route-Bridge
                  S - Switch, H - Host, I - IGMP, r - Repeater,
                  V - VoIP-Phone, D - Remotely-Managed-Device,
                  s - Supports-STP-Dispute

Device-ID          Local Intrfce  Hldtme  Capability  Platform      Port
ID
C1                  Eth1/31        178     R S I s     N3K-C3132Q-V
Eth1/31
C1                  Eth1/32        178     R S I s     N3K-C3132Q-V
Eth1/32

Total entries displayed: 2

```

9. Display the cluster port connectivity on each node:

```
network device-discovery show
```

The following example shows a two-node switchless cluster configuration.

```

cluster::*> network device-discovery show
          Local  Discovered
Node      Port    Device          Interface      Platform
-----
n1        /cdp
          e4a    n2              e4a            FAS9000
          e4e    n2              e4e            FAS9000
n2        /cdp
          e4a    n1              e4a            FAS9000
          e4e    n1              e4e            FAS9000

```

10. Migrate the clus1 interface to the physical port hosting clus2:

```
network interface migrate
```

Execute this command from each local node.

```

cluster::*> network interface migrate -vserver Cluster -lif n1_clus1
-source-node n1
-destination-node n1 -destination-port e4e
cluster::*> network interface migrate -vserver Cluster -lif n2_clus1
-source-node n2
-destination-node n2 -destination-port e4e

```

11. Verify the cluster interfaces migration:

```
network interface show
```

```

cluster::*> network interface show -role cluster
(network interface show)

```

Current Is	Logical	Status	Network	Current	
Vserver	Interface	Admin/Oper	Address/Mask	Node	Port
Home					
-----	-----	-----	-----	-----	-----
Cluster	n1_clus1	up/up	10.10.0.1/24	n1	e4e
false	n1_clus2	up/up	10.10.0.2/24	n1	e4e
true	n2_clus1	up/up	10.10.0.3/24	n2	e4e
false	n2_clus2	up/up	10.10.0.4/24	n2	e4e
true					

4 entries were displayed.

12. Shut down cluster ports clus1 LIF on both nodes:

```
network port modify
```

```

cluster::*> network port modify -node n1 -port e4a -up-admin false
cluster::*> network port modify -node n2 -port e4a -up-admin false

```

13. Ping the remote cluster interfaces and perform an RPC server check:

```
cluster ping-cluster
```



```

cluster::*> cluster ping-cluster -node n1
Host is n1
Getting addresses from network interface table...
Cluster n1_clus1 n1      e4a 10.10.0.1
Cluster n1_clus2 n1      e4e 10.10.0.2
Cluster n2_clus1 n2      e4a 10.10.0.3
Cluster n2_clus2 n2      e4e 10.10.0.4

Local = 10.10.0.1 10.10.0.2
Remote = 10.10.0.3 10.10.0.4
Cluster Vserver Id = 4294967293
Ping status:
....
Basic connectivity succeeds on 4 path(s)
Basic connectivity fails on 0 path(s)
.....
Detected 1500 byte MTU on 32 path(s):
    Local 10.10.0.1 to Remote 10.10.0.3
    Local 10.10.0.1 to Remote 10.10.0.4
    Local 10.10.0.2 to Remote 10.10.0.3
    Local 10.10.0.2 to Remote 10.10.0.4
Larger than PMTU communication succeeds on 4 path(s)
RPC status:
1 paths up, 0 paths down (tcp check)
1 paths up, 0 paths down (ucp check)

```

14. Disconnect the cable from e4a on node n1.

You can refer to the running configuration and connect the first 40 GbE port on the switch C1 (port 1/7 in this example) to e4a on n1 using supported cabling on Nexus 3132Q-V.



When reconnecting any cables to a new Cisco cluster switch, the cables used must be either fiber or cabling supported by Cisco.

15. Disconnect the cable from e4a on node n2.

You can refer to the running configuration and connect e4a to the next available 40 GbE port on C1, port 1/8, using supported cabling.

16. Enable all node-facing ports on C1.

The following example shows ports 1 through 30 being enabled on Nexus 3132Q-V cluster switches C1 and C2 using the configuration supported in RCF

NX3132_RCF_v1.1_24p10g_26p40g.txt:

```
C1# configure
C1(config)# int e1/1/1-4,e1/2/1-4,e1/3/1-4,e1/4/1-4,e1/5/1-4,e1/6/1-4,e1/7-30
C1(config-if-range)# no shutdown
C1(config-if-range)# exit
C1(config)# exit
```

17. Enable the first cluster port, e4a, on each node:

```
network port modify
```

```
cluster::*> network port modify -node n1 -port e4a -up-admin true
cluster::*> network port modify -node n2 -port e4a -up-admin true
```

18. Verify that the clusters are up on both nodes:

```
network port show
```

```

cluster::*> network port show -role cluster
(network port show)
Node: n1

Ignore

Health
Port      IPspace      Broadcast Domain Link MTU  Admin/Oper  Status
Status
-----
-----
e4a      Cluster      Cluster      up    9000 auto/40000  -    -
e4e      Cluster      Cluster      up    9000 auto/40000  -    -

Node: n2

Ignore

Health
Port      IPspace      Broadcast Domain Link MTU  Admin/Oper  Status
Status
-----
-----
e4a      Cluster      Cluster      up    9000 auto/40000  -    -
e4e      Cluster      Cluster      up    9000 auto/40000  -    -
4 entries were displayed.

```

19. For each node, revert all of the migrated cluster interconnect LIFs:

```
network interface revert
```

The following example shows the migrated LIFs being reverted to their home ports.

```

cluster::*> network interface revert -vserver Cluster -lif n1_clus1
cluster::*> network interface revert -vserver Cluster -lif n2_clus1

```

20. Verify that all of the cluster interconnect ports are now reverted to their home ports:

```
network interface show
```

The `Is Home` column should display a value of `true` for all of the ports listed in the `Current Port` column. If the displayed value is `false`, the port has not been reverted.

```

cluster::*> network interface show -role cluster
(network interface show)
      Logical      Status      Network      Current
Current Is
Vserver  Interface  Admin/Oper  Address/Mask  Node      Port
Home
-----
Cluster
true     n1_clus1   up/up      10.10.0.1/24  n1        e4a
true     n1_clus2   up/up      10.10.0.2/24  n1        e4e
true     n2_clus1   up/up      10.10.0.3/24  n2        e4a
true     n2_clus2   up/up      10.10.0.4/24  n2        e4e
true
4 entries were displayed.

```

21. Display the cluster port connectivity on each node:

```
network device-discovery show
```

```

cluster::*> network device-discovery show
      Local  Discovered
Node   Port  Device      Interface      Platform
-----
n1     /cdp
      e4a   C1          Ethernet1/7    N3K-C3132Q-V
      e4e   n2          e4e            FAS9000
n2     /cdp
      e4a   C1          Ethernet1/8    N3K-C3132Q-V
      e4e   n1          e4e            FAS9000

```

22. On the console of each node, migrate clus2 to port e4a:

```
network interface migrate
```

```

cluster::*> network interface migrate -vserver Cluster -lif n1_clus2
-source-node n1
-destination-node n1 -destination-port e4a
cluster::*> network interface migrate -vserver Cluster -lif n2_clus2
-source-node n2
-destination-node n2 -destination-port e4a

```

23. Shut down cluster ports clus2 LIF on both nodes:

```
network port modify
```

The following example shows the specified ports being shut down on both nodes:

```

cluster::*> network port modify -node n1 -port e4e -up-admin false
cluster::*> network port modify -node n2 -port e4e -up-admin false

```

24. Verify the cluster LIF status:

```
network interface show
```

```

cluster::*> network interface show -role cluster
(network interface show)

```

Current Is	Logical	Status	Network	Current	
Vserver	Interface	Admin/Oper	Address/Mask	Node	Port
Home					
-----	-----	-----	-----	-----	-----
-----	-----	-----	-----	-----	-----
Cluster	n1_clus1	up/up	10.10.0.1/24	n1	e4a
true	n1_clus2	up/up	10.10.0.2/24	n1	e4a
false	n2_clus1	up/up	10.10.0.3/24	n2	e4a
true	n2_clus2	up/up	10.10.0.4/24	n2	e4a
false					

4 entries were displayed.

25. Disconnect the cable from e4e on node n1.

You can refer to the running configuration and connect the first 40 GbE port on the switch C2 (port 1/7 in this example) to e4e on n1 using supported cabling on Nexus 3132Q-V.

26. Disconnect the cable from e4e on node n2.

You can refer to the running configuration and connect e4e to the next available 40 GbE port on C2, port 1/8, using supported cabling.

27. Enable all node-facing ports on C2.

The following example shows ports 1 through 30 being enabled on Nexus 3132Q-V cluster switches C1 and C2 using a configuration supported in RCF

NX3132_RCF_v1.1_24p10g_26p40g.txt:

```
C2# configure
C2(config)# int e1/1/1-4,e1/2/1-4,e1/3/1-4,e1/4/1-4,e1/5/1-4,e1/6/1-4,e1/7-30
C2(config-if-range)# no shutdown
C2(config-if-range)# exit
C2(config)# exit
```

28. Enable the second cluster port, e4e, on each node:

```
network port modify
```

The following example shows the specified ports being brought up:

```
cluster::*> network port modify -node n1 -port e4e -up-admin true
cluster::*> network port modify -node n2 -port e4e -up-admin true
```

29. For each node, revert all of the migrated cluster interconnect LIFs:

```
network interface revert
```

The following example shows the migrated LIFs being reverted to their home ports.

```
cluster::*> network interface revert -vserver Cluster -lif n1_clus2
cluster::*> network interface revert -vserver Cluster -lif n2_clus2
```

30. Verify that all of the cluster interconnect ports are now reverted to their home ports:

```
network interface show
```

The `Is Home` column should display a value of `true` for all of the ports listed in the `Current Port` column. If the displayed value is `false`, the port has not been reverted.

```

cluster::*> network interface show -role cluster
(network interface show)

```

Current Is	Logical	Status	Network	Current	
Vserver	Interface	Admin/Oper	Address/Mask	Node	Port
Home					
-----	-----	-----	-----	-----	-----
-----	-----	-----	-----	-----	-----
Cluster	n1_clus1	up/up	10.10.0.1/24	n1	e4a
true	n1_clus2	up/up	10.10.0.2/24	n1	e4e
true	n2_clus1	up/up	10.10.0.3/24	n2	e4a
true	n2_clus2	up/up	10.10.0.4/24	n2	e4e
true					

4 entries were displayed.

31. Verify that all of the cluster interconnect ports are in the up state.

```

cluster::*> network port show -role cluster
(network port show)
Node: n1

Ignore

Speed(Mbps) Health
Health
Port      IPspace      Broadcast Domain Link MTU  Admin/Oper  Status
Status
-----
-----
e4a      Cluster      Cluster      up    9000 auto/40000  -    -
e4e      Cluster      Cluster      up    9000 auto/40000  -    -

Node: n2

Ignore

Speed(Mbps) Health
Health
Port      IPspace      Broadcast Domain Link MTU  Admin/Oper  Status
Status
-----
-----
e4a      Cluster      Cluster      up    9000 auto/40000  -    -
e4e      Cluster      Cluster      up    9000 auto/40000  -    -
4 entries were displayed.

```

32. Display the cluster switch port numbers each cluster port is connected to on each node:

```
network device-discovery show
```

```

cluster::*> network device-discovery show
Local Discovered
Node   Port   Device      Interface      Platform
-----
n1     /cdp
      e4a   C1          Ethernet1/7    N3K-C3132Q-V
      e4e   C2          Ethernet1/7    N3K-C3132Q-V
n2     /cdp
      e4a   C1          Ethernet1/8    N3K-C3132Q-V
      e4e   C2          Ethernet1/8    N3K-C3132Q-V

```

33. Display discovered and monitored cluster switches:

```
system cluster-switch show
```



```
cluster::*> system cluster-switch show
```

```
Switch                Type                Address             Model
-----
C1                    cluster-network    10.10.1.101        NX3132V
  Serial Number: FOX000001
  Is Monitored: true
  Reason:
  Software Version: Cisco Nexus Operating System (NX-OS) Software,
Version
                    7.0(3)I4(1)
  Version Source: CDP

C2                    cluster-network    10.10.1.102        NX3132V
  Serial Number: FOX000002
  Is Monitored: true
  Reason:
  Software Version: Cisco Nexus Operating System (NX-OS) Software,
Version
                    7.0(3)I4(1)
  Version Source: CDP

2 entries were displayed.
```

34. Disable the two-node switchless configuration settings on any node:

```
network options switchless-cluster
```

```
network options switchless-cluster modify -enabled false
```

35. Verify that the switchless-cluster option has been disabled.

```
network options switchless-cluster show
```

36. Ping the remote cluster interfaces and perform an RPC server check:

```
cluster ping-cluster
```

```

cluster::*> cluster ping-cluster -node n1
Host is n1
Getting addresses from network interface table...
Cluster n1_clus1 n1      e4a 10.10.0.1
Cluster n1_clus2 n1      e4e 10.10.0.2
Cluster n2_clus1 n2      e4a 10.10.0.3
Cluster n2_clus2 n2      e4e 10.10.0.4

Local = 10.10.0.1 10.10.0.2
Remote = 10.10.0.3 10.10.0.4
Cluster Vserver Id = 4294967293
Ping status:
....
Basic connectivity succeeds on 4 path(s)
Basic connectivity fails on 0 path(s)
.....
Detected 1500 byte MTU on 32 path(s):
    Local 10.10.0.1 to Remote 10.10.0.3
    Local 10.10.0.1 to Remote 10.10.0.4
    Local 10.10.0.2 to Remote 10.10.0.3
    Local 10.10.0.2 to Remote 10.10.0.4
Larger than PMTU communication succeeds on 4 path(s)
RPC status:
1 paths up, 0 paths down (tcp check)
1 paths up, 0 paths down (ucp check)

```

37. Enable the cluster switch health monitor log collection feature for collecting switch-related log files:

```

system cluster-switch log setup-password

system cluster-switch log enable-collection

```

```

cluster::*> **system cluster-switch log setup-password**
Enter the switch name: <return>
The switch name entered is not recognized.
Choose from the following list:
C1
C2

cluster::*> system cluster-switch log setup-password

Enter the switch name: C1
RSA key fingerprint is e5:8b:c6:dc:e2:18:18:09:36:63:d9:63:dd:03:d9:cc
Do you want to continue? {y|n}::[n] y

Enter the password: <enter switch password>
Enter the password again: <enter switch password>

cluster::*> system cluster-switch log setup-password

Enter the switch name: C2
RSA key fingerprint is 57:49:86:a1:b9:80:6a:61:9a:86:8e:3c:e3:b7:1f:b1
Do you want to continue? {y|n}:: [n] y

Enter the password: <enter switch password>
Enter the password again: <enter switch password>

cluster::*> system cluster-switch log enable-collection

Do you want to enable cluster log collection for all nodes in the
cluster?
{y|n}: [n] y

Enabling cluster switch log collection.

cluster::*>

```



If any of these commands return an error, contact NetApp support.

38. If you suppressed automatic case creation, re-enable it by invoking an AutoSupport message:

```
system node autosupport invoke -node * -type all -message MAINT=END
```

Replace Cisco Nexus 3132Q-V cluster switches

You must be aware of certain configuration information, port connections and cabling requirements when you replace Cisco Nexus 3132Q-V cluster switches.

- The Cisco Nexus 3132Q-V cluster switch is supported.
- The number of 10 GbE and 40/100 GbE ports are defined in the reference configuration files (RCFs) available on the [Cisco® Cluster Network Switch Reference Configuration File Download](#) page.
- The cluster switches use the Inter-Switch Link (ISL) ports e1/31-32.
- The [Hardware Universe](#) contains information about supported cabling to Nexus 3132Q-V switches:
 - The nodes with 10 GbE cluster connections require QSFP optical modules with breakout fiber cables or QSFP to SFP+ copper break-out cables.
 - The nodes with 40/100 GbE cluster connections require supported QSFP/QSFP28 optical modules with fiber cables or QSFP/QSFP28 copper direct-attach cables.
 - The cluster switches use the appropriate ISL cabling: 2x QSFP28 fiber or copper direct-attach cables.
- On Nexus 3132Q-V, you can operate QSFP ports as either 40/100 Gb Ethernet or 4 x10 Gb Ethernet modes.

By default, there are 32 ports in the 40/100 Gb Ethernet mode. These 40 Gb Ethernet ports are numbered in a 2-tuple naming convention. For example, the second 40 Gb Ethernet port is numbered as 1/2. The process of changing the configuration from 40 Gb Ethernet to 10 Gb Ethernet is called *breakout* and the process of changing the configuration from 10 Gb Ethernet to 40 Gb Ethernet is called *breakin*. When you break out a 40/100 Gb Ethernet port into 10 Gb Ethernet ports, the resulting ports are numbered using a 3-tuple naming convention. For example, the breakout ports of the second 40/100 Gb Ethernet port are numbered as 1/2/1, 1/2/2, 1/2/3, 1/2/4.

- On the left side of Nexus 3132Q-V is a set of four SFP+ ports multiplexed to the first QSFP port.

By default, the RCF is structured to use the first QSFP port.

You can make four SFP+ ports active instead of a QSFP port for Nexus 3132Q-V by using the hardware profile `front portmode sfp-plus` command. Similarly, you can reset Nexus 3132Q-V to use a QSFP port instead of four SFP+ ports by using the hardware profile `front portmode qsfp` command.

- You must have configured some of the ports on Nexus 3132Q-V to run at 10 GbE or 40/100 GbE.

You can break-out the first six ports into 4x10 GbE mode by using the `interface breakout module 1 port 1-6 map 10g-4x` command. Similarly, you can regroup the first six QSFP+ ports from breakout configuration by using the `no interface breakout module 1 port 1-6 map 10g-4x` command.

- You must have done the planning, migration, and read the required documentation on 10 GbE and 40/100 GbE connectivity from nodes to Nexus 3132Q-V cluster switches.

The [Cisco Ethernet Switches](#) page has information about the ONTAP and NX-OS versions supported in this procedure.

How to replace Cisco Nexus 3132Q-V cluster switches

Replacing a defective Cisco Nexus 3132Q-V switch in a cluster network is a nondisruptive procedure (NDO), and you must perform a specific sequence of tasks.

Before you begin

- The existing cluster and network configuration must have:

- The Nexus 3132Q-V cluster infrastructure must be redundant and fully functional on both switches.
- The [Cisco Ethernet Switch](#) page has the latest RCF and NX-OS versions on your switches.
- All cluster ports must be in the `up` state.
- Management connectivity must exist on both switches.
- All cluster logical interfaces (LIFs) must be in the `up` state and must not have been migrated.
- The Nexus 3132Q-V replacement switch:
 - Management network connectivity on the replacement switch must be functional.
 - Console access to the replacement switch must be in place.
 - The desired RCF and NX-OS operating system image switch must be loaded onto the switch.
 - Initial customization of the switch must be complete.

About this task

This procedure replaces the second Nexus 3132Q-V cluster switch CL2 with new 3132Q-V switch C2. The examples in this procedure use the following switch and node nomenclature:

- `n1_clus1` is the first cluster logical interface (LIF) connected to cluster switch C1 for node n1.
- `n1_clus2` is the first cluster LIF connected to cluster switch CL2 or C2, for node n1.
- `n1_clus3` is the second LIF connected to cluster switch C2, for node n1.
- `n1_clus4` is the second LIF connected to cluster switch CL1, for node n1.
- The number of 10 GbE and 40/100 GbE ports are defined in the reference configuration files (RCFs) available on the [Cisco® Cluster Network Switch Reference Configuration File Download](#) page.
- The nodes are n1, n2, n3, and n4. - The examples in this procedure use four nodes: Two nodes use four 10 GB cluster interconnect ports: e0a, e0b, e0c, and e0d. The other two nodes use two 40 GB cluster interconnect ports: e4a and e4e. See the [Hardware Universe](#) for the actual cluster ports on your platforms.

This procedure covers the following scenario:

- The cluster starts with four nodes connected to two Nexus 3132Q-V cluster switches, CL1 and CL2.
- Cluster switch CL2 is to be replaced by C2 ([Steps 1 -21](#))
 - On each node, cluster LIFs connected to CL2 are migrated onto cluster ports connected to CL1.
 - Disconnect cabling from all ports on CL2 and reconnect cabling to the same ports on the replacement switch C2.
 - On each node, its migrated cluster LIFs are reverted.

Steps

1. If AutoSupport is enabled on this cluster, suppress automatic case creation by invoking an AutoSupport message:

```
system node autosupport invoke -node * -type all - message MAINT=xh
```

`x` is the duration of the maintenance window in hours.



The AutoSupport message notifies technical support of this maintenance task so that automatic case creation is suppressed during the maintenance window.

2. Display information about the devices in your configuration:

```
network device-discovery show
```

```
cluster::> network device-discovery show
      Local  Discovered
Node   Port   Device           Interface           Platform
-----
n1     /cdp
      e0a   CL1              Ethernet1/1/1       N3K-C3132Q-V
      e0b   CL2              Ethernet1/1/1       N3K-C3132Q-V
      e0c   CL2              Ethernet1/1/2       N3K-C3132Q-V
      e0d   CL1              Ethernet1/1/2       N3K-C3132Q-V
n2     /cdp
      e0a   CL1              Ethernet1/1/3       N3K-C3132Q-V
      e0b   CL2              Ethernet1/1/3       N3K-C3132Q-V
      e0c   CL2              Ethernet1/1/4       N3K-C3132Q-V
      e0d   CL1              Ethernet1/1/4       N3K-C3132Q-V
n3     /cdp
      e4a   CL1              Ethernet1/7         N3K-C3132Q-V
      e4e   CL2              Ethernet1/7         N3K-C3132Q-V
n4     /cdp
      e4a   CL1              Ethernet1/8         N3K-C3132Q-V
      e4e   CL2              Ethernet1/8         N3K-C3132Q-V

12 entries were displayed
```

3. Determine the administrative or operational status for each cluster interface:

a. Display the network port attributes:

```
network port show
```

```
cluster::*> network port show -role cluster
(network port show)

Node: n1

Ignore

Health                                                    Speed(Mbps) Health
Port      IPspace      Broadcast Domain Link MTU  Admin/Oper  Status
Status
-----
-----
```

```

e0a      Cluster      Cluster      up    9000 auto/10000 -
-
e0b      Cluster      Cluster      up    9000 auto/10000 -
-
e0c      Cluster      Cluster      up    9000 auto/10000 -
-
e0d      Cluster      Cluster      up    9000 auto/10000 -
-

```

Node: n2

Ignore

```

                                                    Speed(Mbps) Health
Health
Port      IPspace      Broadcast Domain Link MTU  Admin/Oper  Status
Status
-----
-----
e0a      Cluster      Cluster      up    9000 auto/10000 -
-
e0b      Cluster      Cluster      up    9000 auto/10000 -
-
e0c      Cluster      Cluster      up    9000 auto/10000 -
-
e0d      Cluster      Cluster      up    9000 auto/10000 -
-

```

Node: n3

Ignore

```

                                                    Speed(Mbps) Health
Health
Port      IPspace      Broadcast Domain Link MTU  Admin/Oper  Status
Status
-----
-----
e4a      Cluster      Cluster      up    9000 auto/40000 -
-
e4e      Cluster      Cluster      up    9000 auto/40000 -
-

```

Node: n4

Ignore

```

                                                    Speed(Mbps) Health
Health

```

```
Port      IPspace      Broadcast Domain Link MTU  Admin/Oper  Status
-----
-----
e4a       Cluster      Cluster      up   9000 auto/40000  -
-
e4e       Cluster      Cluster      up   9000 auto/40000  -
-
12 entries were displayed.
```

b. Display information about the logical interfaces:

```
network interface show
```



```
cluster::*> network interface show -role cluster
(network interface show)
```

Current Is	Logical Interface	Status Admin/Oper	Network Address/Mask	Current Node
Vserver Port	Home			

Cluster				
e0a	true	n1_clus1 up/up	10.10.0.1/24	n1
e0b	true	n1_clus2 up/up	10.10.0.2/24	n1
e0c	true	n1_clus3 up/up	10.10.0.3/24	n1
e0d	true	n1_clus4 up/up	10.10.0.4/24	n1
e0a	true	n2_clus1 up/up	10.10.0.5/24	n2
e0b	true	n2_clus2 up/up	10.10.0.6/24	n2
e0c	true	n2_clus3 up/up	10.10.0.7/24	n2
e0d	true	n2_clus4 up/up	10.10.0.8/24	n2
e0a	true	n3_clus1 up/up	10.10.0.9/24	n3
e0e	true	n3_clus2 up/up	10.10.0.10/24	n3
e0a	true	n4_clus1 up/up	10.10.0.11/24	n4
e0e	true	n4_clus2 up/up	10.10.0.12/24	n4

12 entries were displayed.

c. Display the information on the discovered cluster switches:

```
system cluster-switch show
```

```

cluster::> system cluster-switch show

Switch                               Type                               Address                               Model
-----                               -
CL1                                  cluster-network                    10.10.1.101
NX3132V
  Serial Number: FOX000001
  Is Monitored: true
  Reason:
  Software Version: Cisco Nexus Operating System (NX-OS) Software,
Version
                        7.0(3)I4(1)
  Version Source: CDP

CL2                                  cluster-network                    10.10.1.102
NX3132V
  Serial Number: FOX000002
  Is Monitored: true
  Reason:
  Software Version: Cisco Nexus Operating System (NX-OS) Software,
Version
                        7.0(3)I4(1)
  Version Source: CDP

2 entries were displayed.

```

4. Verify that the appropriate RCF and image are installed on the new Nexus 3132Q-V switch as necessary for your requirements, and make any essential site customizations.

You must prepare the replacement switch at this time. If you need to upgrade the RCF and image, you must follow these steps:

- a. On the NetApp Support Site, go to the [Cisco Ethernet Switch](#) page.
 - b. Note your switch and the required software versions in the table on that page.
 - c. Download the appropriate version of the RCF.
 - d. Click **CONTINUE** on the **Description** page, accept the license agreement, and then follow the instructions on the **Download** page to download the RCF.
 - e. Download the appropriate version of the image software.
5. Migrate the LIFs associated to the cluster ports connected to switch C2:

```
network interface migrate
```

This example shows that the LIF migration is done on all the nodes:

```
cluster::*> network interface migrate -vserver Cluster -lif n1_clus2
-source-node n1 -destination-node n1 -destination-port e0a
cluster::*> network interface migrate -vserver Cluster -lif n1_clus3
-source-node n1 -destination-node n1 -destination-port e0d
cluster::*> network interface migrate -vserver Cluster -lif n2_clus2
-source-node n2 -destination-node n2 -destination-port e0a
cluster::*> network interface migrate -vserver Cluster -lif n2_clus3
-source-node n2 -destination-node n2 -destination-port e0d
cluster::*> network interface migrate -vserver Cluster -lif n3_clus2
-source-node n3 -destination-node n3 -destination-port e4a
cluster::*> network interface migrate -vserver Cluster -lif n4_clus2
-source-node n4 -destination-node n4 -destination-port e4a
```

6. Verify cluster's health:

```
network interface show
```

```
cluster::*> network interface show -role cluster
(network interface show)
```

Current Is	Logical	Status	Network	Current	
Vserver	Interface	Admin/Oper	Address/Mask	Node	Port
Home					
-----	-----	-----	-----	-----	
-----	-----	-----	-----	-----	
Cluster					
true	n1_clus1	up/up	10.10.0.1/24	n1	e0a
false	n1_clus2	up/up	10.10.0.2/24	n1	e0a
false	n1_clus3	up/up	10.10.0.3/24	n1	e0d
true	n1_clus4	up/up	10.10.0.4/24	n1	e0d
true	n2_clus1	up/up	10.10.0.5/24	n2	e0a
false	n2_clus2	up/up	10.10.0.6/24	n2	e0a
false	n2_clus3	up/up	10.10.0.7/24	n2	e0d
true	n2_clus4	up/up	10.10.0.8/24	n2	e0d
true	n3_clus1	up/up	10.10.0.9/24	n3	e4a
false	n3_clus2	up/up	10.10.0.10/24	n3	e4a
true	n4_clus1	up/up	10.10.0.11/24	n4	e4a
false	n4_clus2	up/up	10.10.0.12/24	n4	e4a

12 entries were displayed.

7. Shut down the cluster interconnect ports that are physically connected to switch CL2:

```
network port modify
```

This example shows the specified ports being shut down on all nodes:

```

cluster::*> network port modify -node n1 -port e0b -up-admin false
cluster::*> network port modify -node n1 -port e0c -up-admin false
cluster::*> network port modify -node n2 -port e0b -up-admin false
cluster::*> network port modify -node n2 -port e0c -up-admin false
cluster::*> network port modify -node n3 -port e4e -up-admin false
cluster::*> network port modify -node n4 -port e4e -up-admin false

```

8. Ping the remote cluster interfaces and perform an RPC server check:

```
cluster ping-cluster
```

```

cluster::*> cluster ping-cluster -node n1
Host is n1
Getting addresses from network interface table...
Cluster n1_clus1 n1      e0a 10.10.0.1
Cluster n1_clus2 n1      e0b 10.10.0.2
Cluster n1_clus3 n1      e0c 10.10.0.3
Cluster n1_clus4 n1      e0d 10.10.0.4
Cluster n2_clus1 n2      e0a 10.10.0.5
Cluster n2_clus2 n2      e0b 10.10.0.6
Cluster n2_clus3 n2      e0c 10.10.0.7
Cluster n2_clus4 n2      e0d 10.10.0.8
Cluster n3_clus1 n4      e0a 10.10.0.9
Cluster n3_clus2 n3      e0e 10.10.0.10
Cluster n4_clus1 n4      e0a 10.10.0.11
Cluster n4_clus2 n4      e0e 10.10.0.12

Local = 10.10.0.1 10.10.0.2 10.10.0.3 10.10.0.4
Remote = 10.10.0.5 10.10.0.6 10.10.0.7 10.10.0.8 10.10.0.9 10.10.0.10
10.10.0.11 10.10.0.12
Cluster Vserver Id = 4294967293
Ping status:
....
Basic connectivity succeeds on 32 path(s)
Basic connectivity fails on 0 path(s)
.....
Detected 1500 byte MTU on 32 path(s):
  Local 10.10.0.1 to Remote 10.10.0.5
  Local 10.10.0.1 to Remote 10.10.0.6
  Local 10.10.0.1 to Remote 10.10.0.7
  Local 10.10.0.1 to Remote 10.10.0.8
  Local 10.10.0.1 to Remote 10.10.0.9
  Local 10.10.0.1 to Remote 10.10.0.10
  Local 10.10.0.1 to Remote 10.10.0.11
  Local 10.10.0.1 to Remote 10.10.0.12

```

```
Local 10.10.0.2 to Remote 10.10.0.5
Local 10.10.0.2 to Remote 10.10.0.6
Local 10.10.0.2 to Remote 10.10.0.7
Local 10.10.0.2 to Remote 10.10.0.8
Local 10.10.0.2 to Remote 10.10.0.9
Local 10.10.0.2 to Remote 10.10.0.10
Local 10.10.0.2 to Remote 10.10.0.11
Local 10.10.0.2 to Remote 10.10.0.12
Local 10.10.0.3 to Remote 10.10.0.5
Local 10.10.0.3 to Remote 10.10.0.6
Local 10.10.0.3 to Remote 10.10.0.7
Local 10.10.0.3 to Remote 10.10.0.8
Local 10.10.0.3 to Remote 10.10.0.9
Local 10.10.0.3 to Remote 10.10.0.10
Local 10.10.0.3 to Remote 10.10.0.11
Local 10.10.0.3 to Remote 10.10.0.12
Local 10.10.0.4 to Remote 10.10.0.5
Local 10.10.0.4 to Remote 10.10.0.6
Local 10.10.0.4 to Remote 10.10.0.7
Local 10.10.0.4 to Remote 10.10.0.8
Local 10.10.0.4 to Remote 10.10.0.9
Local 10.10.0.4 to Remote 10.10.0.10
Local 10.10.0.4 to Remote 10.10.0.11
Local 10.10.0.4 to Remote 10.10.0.12
```

Larger than PMTU communication succeeds on 32 path(s)

RPC status:

8 paths up, 0 paths down (tcp check)

8 paths up, 0 paths down (udp check)

9. Shut down the ports 1/31 and 1/32 on CL1, and the active Nexus 3132Q-V switch:

```
shutdown
```

This example shows the ISL ports 1/31 and 1/32 being shut down on switch CL1:

```
(CL1)# configure
(CL1)(Config)# interface e1/31-32
(CL1(config-if-range)# shutdown
(CL1(config-if-range)# exit
(CL1)(Config)# exit
(CL1)#
```

10. Remove all the cables attached to the Nexus 3132Q-V switch CL2 and reconnect them to the replacement switch C2 on all nodes.

11. Remove the ISL cables from ports e1/31 and e1/32 on CL2 and reconnect them to the same ports on the replacement switch C2.
12. Bring up ISLs ports 1/31 and 1/32 on the Nexus 3132Q-V switch CL1.

```
(CL1)# configure
(CL1) (Config)# interface e1/31-32
(CL1(config-if-range)# no shutdown
(CL1(config-if-range)# exit
(CL1) (Config)# exit
(CL1)#
```

13. Verify that the ISLs are up on CL1:

```
show port-channel
```

Ports Eth1/31 and Eth1/32 should indicate (P), which means that the ISL ports are up in the port-channel.

```
CL1# show port-channel summary
Flags: D - Down          P - Up in port-channel (members)
      I - Individual    H - Hot-standby (LACP only)
      s - Suspended     r - Module-removed
      S - Switched      R - Routed
      U - Up (port-channel)
      M - Not in use. Min-links not met

-----
-----
Group Port-          Type   Protocol  Member                      Ports
  Channel
-----
-----
1      Po1(SU)        Eth    LACP      Eth1/31(P)  Eth1/32(P)
```

14. Verify that the ISLs are up on C2:

```
show port-channel summary
```

Ports Eth1/31 and Eth1/32 should indicate (P), which means that both ISL ports are up in the port-channel.

```
C2# show port-channel summary
Flags: D - Down          P - Up in port-channel (members)
       I - Individual    H - Hot-standby (LACP only)
       s - Suspended     r - Module-removed
       S - Switched     R - Routed
       U - Up (port-channel)
       M - Not in use. Min-links not met
```

```
-----
-----
Group Port-          Type   Protocol  Member Ports
Channel
-----
-----
1      Po1 (SU)      Eth     LACP      Eth1/31 (P)  Eth1/32 (P)
```

15. On all nodes, bring up all the cluster interconnect ports connected to the Nexus 3132Q-V switch C2:
network port modify

```
cluster::*> network port modify -node n1 -port e0b -up-admin true
cluster::*> network port modify -node n1 -port e0c -up-admin true
cluster::*> network port modify -node n2 -port e0b -up-admin true
cluster::*> network port modify -node n2 -port e0c -up-admin true
cluster::*> network port modify -node n3 -port e4e -up-admin true
cluster::*> network port modify -node n4 -port e4e -up-admin true
```

16. For all nodes, revert all of the migrated cluster interconnect LIFs:

```
network interface revert
```

```
cluster::*> network interface revert -vserver Cluster -lif n1_clus2
cluster::*> network interface revert -vserver Cluster -lif n1_clus3
cluster::*> network interface revert -vserver Cluster -lif n2_clus2
cluster::*> network interface revert -vserver Cluster -lif n2_clus3
Cluster::*> network interface revert -vserver Cluster -lif n3_clus2
Cluster::*> network interface revert -vserver Cluster -lif n4_clus2
```

17. Verify that the cluster interconnect ports are now reverted to their home:

```
network interface show
```

This example shows that all the LIFs are successfully reverted because the ports listed under the **Current Port** column have a status of `true` in the **Is Home** column. If the **Is Home** column value is `false`, the LIF has not been reverted.

```

cluster::*> network interface show -role cluster
(network interface show)

```

Current Is	Logical	Status	Network	Current	
Vserver	Interface	Admin/Oper	Address/Mask	Node	Port
Home					
-----	-----	-----	-----	-----	-----
Cluster					
true	n1_clus1	up/up	10.10.0.1/24	n1	e0a
true	n1_clus2	up/up	10.10.0.2/24	n1	e0b
true	n1_clus3	up/up	10.10.0.3/24	n1	e0c
true	n1_clus4	up/up	10.10.0.4/24	n1	e0d
true	n2_clus1	up/up	10.10.0.5/24	n2	e0a
true	n2_clus2	up/up	10.10.0.6/24	n2	e0b
true	n2_clus3	up/up	10.10.0.7/24	n2	e0c
true	n2_clus4	up/up	10.10.0.8/24	n2	e0d
true	n3_clus1	up/up	10.10.0.9/24	n3	e4a
true	n3_clus2	up/up	10.10.0.10/24	n3	e4e
true	n4_clus1	up/up	10.10.0.11/24	n4	e4a
true	n4_clus2	up/up	10.10.0.12/24	n4	e4e

12 entries were displayed.

18. Verify that the cluster ports are connected:

```
network port show
```

```

cluster::*> network port show -role cluster
(network port show)
Node: n1

Ignore

Speed (Mbps) Health

```

Health

Port	IPspace	Broadcast	Domain	Link	MTU	Admin/Oper	Status
------	---------	-----------	--------	------	-----	------------	--------

e0a	Cluster	Cluster		up	9000	auto/10000	-	-
e0b	Cluster	Cluster		up	9000	auto/10000	-	-
e0c	Cluster	Cluster		up	9000	auto/10000	-	-
e0d	Cluster	Cluster		up	9000	auto/10000	-	-

Node: n2

Ignore

Speed(Mbps) Health

Health

Port	IPspace	Broadcast	Domain	Link	MTU	Admin/Oper	Status
------	---------	-----------	--------	------	-----	------------	--------

e0a	Cluster	Cluster		up	9000	auto/10000	-	-
e0b	Cluster	Cluster		up	9000	auto/10000	-	-
e0c	Cluster	Cluster		up	9000	auto/10000	-	-
e0d	Cluster	Cluster		up	9000	auto/10000	-	-

Node: n3

Ignore

Speed(Mbps) Health

Health

Port	IPspace	Broadcast	Domain	Link	MTU	Admin/Oper	Status
------	---------	-----------	--------	------	-----	------------	--------

e4a	Cluster	Cluster		up	9000	auto/40000	-	-
e4e	Cluster	Cluster		up	9000	auto/40000	-	-

Node: n4

Ignore

Speed(Mbps) Health

Health

Port	IPspace	Broadcast	Domain	Link	MTU	Admin/Oper	Status
------	---------	-----------	--------	------	-----	------------	--------

e4a	Cluster	Cluster		up	9000	auto/40000	-	-
-----	---------	---------	--	----	------	------------	---	---

```
e4e      Cluster      Cluster      up      9000 auto/40000 -      -  
12 entries were displayed.
```

19. Ping the remote cluster interfaces and perform an RPC server check:

```
cluster ping-cluster
```

```
cluster::*> cluster ping-cluster -node n1  
Host is n1  
Getting addresses from network interface table...  
Cluster n1_clus1 n1      e0a 10.10.0.1  
Cluster n1_clus2 n1      e0b 10.10.0.2  
Cluster n1_clus3 n1      e0c 10.10.0.3  
Cluster n1_clus4 n1      e0d 10.10.0.4  
Cluster n2_clus1 n2      e0a 10.10.0.5  
Cluster n2_clus2 n2      e0b 10.10.0.6  
Cluster n2_clus3 n2      e0c 10.10.0.7  
Cluster n2_clus4 n2      e0d 10.10.0.8  
Cluster n3_clus1 n3      e0a 10.10.0.9  
Cluster n3_clus2 n3      e0e 10.10.0.10  
Cluster n4_clus1 n4      e0a 10.10.0.11  
Cluster n4_clus2 n4      e0e 10.10.0.12  
  
Local = 10.10.0.1 10.10.0.2 10.10.0.3 10.10.0.4  
Remote = 10.10.0.5 10.10.0.6 10.10.0.7 10.10.0.8 10.10.0.9 10.10.0.10  
10.10.0.11 10.10.0.12  
Cluster Vserver Id = 4294967293  
Ping status:  
....  
Basic connectivity succeeds on 32 path(s)  
Basic connectivity fails on 0 path(s)  
.....  
Detected 1500 byte MTU on 32 path(s):  
  Local 10.10.0.1 to Remote 10.10.0.5  
  Local 10.10.0.1 to Remote 10.10.0.6  
  Local 10.10.0.1 to Remote 10.10.0.7  
  Local 10.10.0.1 to Remote 10.10.0.8  
  Local 10.10.0.1 to Remote 10.10.0.9  
  Local 10.10.0.1 to Remote 10.10.0.10  
  Local 10.10.0.1 to Remote 10.10.0.11  
  Local 10.10.0.1 to Remote 10.10.0.12  
  Local 10.10.0.2 to Remote 10.10.0.5  
  Local 10.10.0.2 to Remote 10.10.0.6  
  Local 10.10.0.2 to Remote 10.10.0.7  
  Local 10.10.0.2 to Remote 10.10.0.8  
  Local 10.10.0.2 to Remote 10.10.0.9
```

```
Local 10.10.0.2 to Remote 10.10.0.10
Local 10.10.0.2 to Remote 10.10.0.11
Local 10.10.0.2 to Remote 10.10.0.12
Local 10.10.0.3 to Remote 10.10.0.5
Local 10.10.0.3 to Remote 10.10.0.6
Local 10.10.0.3 to Remote 10.10.0.7
Local 10.10.0.3 to Remote 10.10.0.8
Local 10.10.0.3 to Remote 10.10.0.9
Local 10.10.0.3 to Remote 10.10.0.10
Local 10.10.0.3 to Remote 10.10.0.11
Local 10.10.0.3 to Remote 10.10.0.12
Local 10.10.0.4 to Remote 10.10.0.5
Local 10.10.0.4 to Remote 10.10.0.6
Local 10.10.0.4 to Remote 10.10.0.7
Local 10.10.0.4 to Remote 10.10.0.8
Local 10.10.0.4 to Remote 10.10.0.9
Local 10.10.0.4 to Remote 10.10.0.10
Local 10.10.0.4 to Remote 10.10.0.11
Local 10.10.0.4 to Remote 10.10.0.12
```

Larger than PMTU communication succeeds on 32 path(s)

RPC status:

8 paths up, 0 paths down (tcp check)

8 paths up, 0 paths down (udp check)

20. Display the information about the devices in your configuration:

- ° network device-discovery show
- ° network port show -role cluster
- ° network interface show -role cluster
- ° system cluster-switch show

```

cluster::> network device-discovery show
      Local  Discovered
Node   Port    Device           Interface         Platform
-----
n1     /cdp
      e0a    C1               Ethernet1/1/1     N3K-C3132Q-V
      e0b    C2               Ethernet1/1/1     N3K-C3132Q-V
      e0c    C2               Ethernet1/1/2     N3K-C3132Q-V
      e0d    C1               Ethernet1/1/2     N3K-C3132Q-V
n2     /cdp
      e0a    C1               Ethernet1/1/3     N3K-C3132Q-V
      e0b    C2               Ethernet1/1/3     N3K-C3132Q-V
      e0c    C2               Ethernet1/1/4     N3K-C3132Q-V
      e0d    C1               Ethernet1/1/4     N3K-C3132Q-V
n3     /cdp
      e4a    C1               Ethernet1/7       N3K-C3132Q-V
      e4e    C2               Ethernet1/7       N3K-C3132Q-V
n4     /cdp
      e4a    C1               Ethernet1/8       N3K-C3132Q-V
      e4e    C2               Ethernet1/8       N3K-C3132Q-V
12 entries were displayed.

```

```

cluster::*> network port show -role cluster
(network port show)
Node: n1

Ignore

Health
Port      IPspace      Broadcast Domain Link MTU  Admin/Oper  Status
Status
-----
e0a      Cluster      Cluster      up   9000 auto/10000  -
-
e0b      Cluster      Cluster      up   9000 auto/10000  -
-
e0c      Cluster      Cluster      up   9000 auto/10000  -
-
e0d      Cluster      Cluster      up   9000 auto/10000  -
-

Node: n2

```

```

Ignore
Speed(Mbps) Health
Health
Port      IPspace      Broadcast Domain Link MTU  Admin/Oper  Status
Status
-----
-----
e0a      Cluster      Cluster      up    9000  auto/10000  -
-
e0b      Cluster      Cluster      up    9000  auto/10000  -
-
e0c      Cluster      Cluster      up    9000  auto/10000  -
-
e0d      Cluster      Cluster      up    9000  auto/10000  -
-

```

Node: n3

```

Ignore
Speed(Mbps) Health
Health
Port      IPspace      Broadcast Domain Link MTU  Admin/Oper  Status
Status
-----
-----
e4a      Cluster      Cluster      up    9000  auto/40000  -
-
e4e      Cluster      Cluster      up    9000  auto/40000  -
-

```

Node: n4

```

Ignore
Speed(Mbps) Health
Health
Port      IPspace      Broadcast Domain Link MTU  Admin/Oper  Status
Status
-----
-----
e4a      Cluster      Cluster      up    9000  auto/40000  -
-
e4e      Cluster      Cluster      up    9000  auto/40000  -
-

```

12 entries were displayed.

```
cluster::*> network interface show -role cluster
```

```
(network interface show)
```

Current Is	Logical	Status	Network	Current	
Vserver	Interface	Admin/Oper	Address/Mask	Node	
Port	Home				

Cluster					
e0a	true	n1_clus1	up/up	10.10.0.1/24	n1
e0b	true	n1_clus2	up/up	10.10.0.2/24	n1
e0c	true	n1_clus3	up/up	10.10.0.3/24	n1
e0d	true	n1_clus4	up/up	10.10.0.4/24	n1
e0a	true	n2_clus1	up/up	10.10.0.5/24	n2
e0b	true	n2_clus2	up/up	10.10.0.6/24	n2
e0c	true	n2_clus3	up/up	10.10.0.7/24	n2
e0d	true	n2_clus4	up/up	10.10.0.8/24	n2
e4a	true	n3_clus1	up/up	10.10.0.9/24	n3
e4e	true	n3_clus2	up/up	10.10.0.10/24	n3
e4a	true	n4_clus1	up/up	10.10.0.11/24	n4
e4e	true	n4_clus2	up/up	10.10.0.12/24	n4

```
12 entries were displayed.
```

```
cluster::*> system cluster-switch show
```

```
Switch                               Type                               Address                               Model
-----                               -
CL1                                  cluster-network                   10.10.1.101                          NX3132V
  Serial Number: FOX000001
  Is Monitored: true
  Reason:
  Software Version: Cisco Nexus Operating System (NX-OS) Software,
Version
                        7.0(3)I4(1)
  Version Source: CDP

CL2                                  cluster-network                   10.10.1.102                          NX3132V
  Serial Number: FOX000002
  Is Monitored: true
  Reason:
  Software Version: Cisco Nexus Operating System (NX-OS) Software,
Version
                        7.0(3)I4(1)
  Version Source: CDP

C2                                   cluster-network                   10.10.1.103                          NX3132V
  Serial Number: FOX000003
  Is Monitored: true
  Reason:
  Software Version: Cisco Nexus Operating System (NX-OS) Software,
Version
                        7.0(3)I4(1)
  Version Source: CDP

3 entries were displayed.
```

21. Remove the replaced Nexus 3132Q-V switch, if it is not already removed automatically:

```
system cluster-switch delete
```

```
cluster::*> system cluster-switch delete -device CL2
```

22. Verify that the proper cluster switches are monitored:

```
system cluster-switch show
```



```
cluster::> system cluster-switch show
```

Switch	Type	Address	Model
CL1	cluster-network	10.10.1.101	NX3132V
Serial Number: FOX000001			
Is Monitored: true			
Reason:			
Software Version: Cisco Nexus Operating System (NX-OS) Software,			
Version			
7.0(3)I4(1)			
Version Source: CDP			
C2	cluster-network	10.10.1.103	NX3132V
Serial Number: FOX000002			
Is Monitored: true			
Reason:			
Software Version: Cisco Nexus Operating System (NX-OS) Software,			
Version			
7.0(3)I4(1)			
Version Source: CDP			

2 entries were displayed.

23. Enable the cluster switch health monitor log collection feature for collecting switch-related log files:

```
system cluster-switch log setup-password
```

```
system cluster-switch log enable-collection
```

```

cluster::*> system cluster-switch log setup-password
Enter the switch name: <return>
The switch name entered is not recognized.
Choose from the following list:
C1
C2

cluster::*> system cluster-switch log setup-password

Enter the switch name: C1
RSA key fingerprint is e5:8b:c6:dc:e2:18:18:09:36:63:d9:63:dd:03:d9:cc
Do you want to continue? {y|n}::[n] y

Enter the password: <enter switch password>
Enter the password again: <enter switch password>

cluster::*> system cluster-switch log setup-password

Enter the switch name: C2
RSA key fingerprint is 57:49:86:a1:b9:80:6a:61:9a:86:8e:3c:e3:b7:1f:b1
Do you want to continue? {y|n}:: [n] y

Enter the password: <enter switch password>
Enter the password again: <enter switch password>

cluster::*> system cluster-switch log enable-collection

Do you want to enable cluster log collection for all nodes in the
cluster?
{y|n}: [n] y

Enabling cluster switch log collection.

cluster::*>

```



If any of these commands return an error, contact NetApp support.

24. If you suppressed automatic case creation, re-enable it by invoking an AutoSupport message:

```
system node autosupport invoke -node * -type all -message MAINT=END
```

Related information

[Cisco Ethernet Switch description page](#)

[Hardware Universe](#)

Replace a Cisco Nexus 5596 cluster switch with a Cisco Nexus 3132Q-V cluster switch

You must be aware of certain configuration information, port connections and cabling requirements when you are replacing a Cisco Nexus 5596 cluster switch with a Cisco Nexus 3132Q-V cluster switch.

- The following cluster switches are supported:
 - Nexus 5596
 - Nexus 3132Q-V
- The number of 10 GbE and 40/100 GbE ports are defined in the reference configuration files (RCFs) available on the [Cisco® Cluster Network Switch Reference Configuration File Download](#) page.
- The cluster switches use the following ports for connections to nodes:
 - Ports e1/1-40 (10 GbE): Nexus 5596
 - Ports e1/1-30 (40/100 GbE): Nexus 3132Q-V
- The cluster switches use the following Inter-Switch Link (ISL) ports:
 - Ports e1/41-48 (10 GbE): Nexus 5596
 - Ports e1/31-32 (40/100 GbE): Nexus 3132Q-V
- The [Hardware Universe](#) contains information about supported cabling to Nexus 3132Q-V switches:
 - Nodes with 10 GbE cluster connections require QSFP to SFP+ optical fiber breakout cables or QSFP to SFP+ copper breakout cables.
 - Nodes with 40/100 GbE cluster connections require supported QSFP/QSFP28 optical modules with fiber cables or QSFP/QSFP28 copper direct-attach cables.
- The cluster switches use the appropriate ISL cabling:
 - Beginning: Nexus 5596 to Nexus 5596 (SFP+ to SFP+)
 - 8x SFP+ fiber or copper direct-attach cables
 - Interim: Nexus 5596 to Nexus 3132Q-V (QSFP to 4xSFP+ break-out)
 - 1x QSFP to SFP+ fiber break-out or copper break-out cables
 - Final: Nexus 3132Q-V to Nexus 3132Q-V (QSFP28 to QSFP28)
 - 2x QSFP28 fiber or copper direct-attach cables
- On Nexus 3132Q-V switches, you can operate QSFP/QSFP28 ports as either 40/100 Gigabit Ethernet or 4 x10 Gigabit Ethernet modes.

By default, there are 32 ports in the 40/100 Gigabit Ethernet mode. These 40 Gigabit Ethernet ports are numbered in a 2-tuple naming convention. For example, the second 40 Gigabit Ethernet port is numbered as 1/2. The process of changing the configuration from 40 Gigabit Ethernet to 10 Gigabit Ethernet is called *breakout* and the process of changing the configuration from 10 Gigabit Ethernet to 40 Gigabit Ethernet is called *breakin*. When you break out a 40/100 Gigabit Ethernet port into 10 Gigabit Ethernet ports, the resulting ports are numbered using a 3-tuple naming convention. For example, the break-out ports of the second 40 Gigabit Ethernet port are numbered as 1/2/1, 1/2/2, 1/2/3, and 1/2/4.

- On the left side of Nexus 3132Q-V switches is a set of 4 SFP+ ports multiplexed to that QSFP28 port.

By default, the RCF is structured to use the QSFP28 port.



You can make 4x SFP+ ports active instead of a QSFP port for Nexus 3132Q-V switches by using the `hardware profile front portmode sfp-plus` command. Similarly, you can reset Nexus 3132Q-V switches to use a QSFP port instead of 4x SFP+ ports by using the `hardware profile front portmode qsfp` command.

- You have configured some of the ports on Nexus 3132Q-V switches to run at 10 GbE or 40/100 GbE.



You can break out the first six ports into 4x10 GbE mode by using the `interface breakout module 1 port 1-6 map 10g-4x` command. Similarly, you can regroup the first six QSFP+ ports from breakout configuration by using the `no interface breakout module 1 port 1-6 map 10g-4x` command.

- You have done the planning, migration, and read the required documentation on 10 GbE and 40/100 GbE connectivity from nodes to Nexus 3132Q-V cluster switches.
- The ONTAP and NX-OS versions supported in this procedure are on the [Cisco Ethernet Switches](#) page.

How to replace a Cisco Nexus 5596 cluster switch with a Cisco Nexus 3132Q-V cluster switch

To replace an existing Nexus 5596 cluster switch with a Nexus 3132Q-V cluster switch, you must perform a specific sequence of tasks.

About this task

The examples in this procedure describe replacing Nexus 5596 switches with Nexus 3132Q-V switches. You can use these steps (with modifications) to replace other older Cisco switches. The procedure uses the following switch and node nomenclature:

- The command outputs might vary depending on different releases of ONTAP.
- The Nexus 5596 switches to be replaced are CL1 and CL2.
- The Nexus 3132Q-V switches to replace the Nexus 5596 switches are C1 and C2.
- n1_clus1 is the first cluster logical interface (LIF) connected to cluster switch 1 (CL1 or C1) for node n1.
- n1_clus2 is the first cluster LIF connected to cluster switch 2 (CL2 or C2) for node n1.
- n1_clus3 is the second LIF connected to cluster switch 2 (CL2 or C2) for node n1.
- n1_clus4 is the second LIF connected to cluster switch 1 (CL1 or C1) for node n1.
- The nodes are n1, n2, n3, and n4.
- The examples in this procedure use four nodes: Two nodes use four 10 GbE cluster interconnect ports: e0a, e0b, e0c, and e0d. The other two nodes use two 40/100 GbE cluster interconnect ports: e4a, e4e. The [Hardware Universe](#) lists the actual cluster ports on your platforms.
- The number of 10 GbE and 40/100 GbE ports are defined in the reference configuration files (RCFs) available on the [Cisco® Cluster Network Switch Reference Configuration File Download](#) page.



The procedure requires the use of both ONTAP commands and Cisco Nexus 3000 Series Switches commands; ONTAP commands are used unless otherwise indicated.

This procedure covers the following scenarios:

- The cluster starts with two nodes connected and functioning in a 2 Nexus 5596 cluster switches.
- The cluster switch CL2 to be replaced by C2 ([Steps 1 - 19](#))
 - Traffic on all cluster ports and LIFs on all nodes connected to CL2 are migrated onto the first cluster ports and LIFs connected to CL1.
 - Disconnect cabling from all cluster ports on all nodes connected to CL2, and then use supported break-out cabling to reconnect the ports to new cluster switch C2.
 - Disconnect cabling between ISL ports between CL1 and CL2, and then use supported break-out cabling to reconnect the ports from CL1 to C2.
 - Traffic on all cluster ports and LIFs connected to C2 on all nodes is reverted.
- The cluster switch CL2 to be replaced by C2 ([Steps 20 - 33](#))
 - Traffic on all cluster ports or LIFs on all nodes connected to CL1 are migrated onto the second cluster ports or LIFs connected to C2.
 - Disconnect cabling from all cluster port on all nodes connected to CL1 and reconnect, using supported break-out cabling, to new cluster switch C1.
 - Disconnect cabling between ISL ports between CL1 and C2, and reconnect using supported cabling, from C1 to C2.
 - Traffic on all cluster ports or LIFs connected to C1 on all nodes is reverted.
- Two FAS9000 nodes have been added to cluster with examples showing cluster details ([Steps 34 - 37](#)).

Steps

1. If AutoSupport is enabled on this cluster, suppress automatic case creation by invoking an AutoSupport message: `system node autosupport invoke -node * -type all -message MAINT=xh`

`x` is the duration of the maintenance window in hours.



The message notifies technical support of this maintenance task so that automatic case creation is suppressed during the maintenance window.

2. Display information about the devices in your configuration:

```
network device-discovery show
```

The following example shows how many cluster interconnect interfaces have been configured in each node for each cluster interconnect switch:

```
cluster::> network device-discovery show
```

Node	Local Port	Discovered Device	Interface	Platform
n1	/cdp			
	e0a	CL1	Ethernet1/1	N5K-C5596UP
	e0b	CL2	Ethernet1/1	N5K-C5596UP
	e0c	CL2	Ethernet1/2	N5K-C5596UP
	e0d	CL1	Ethernet1/2	N5K-C5596UP
n2	/cdp			
	e0a	CL1	Ethernet1/3	N5K-C5596UP
	e0b	CL2	Ethernet1/3	N5K-C5596UP
	e0c	CL2	Ethernet1/4	N5K-C5596UP
	e0d	CL1	Ethernet1/4	N5K-C5596UP

```
8 entries were displayed.
```

3. Determine the administrative or operational status for each cluster interface:

a. Display the network port attributes:

```
network port show
```

The following example displays the network port attributes on a system:

```

cluster::*> network port show -role cluster
(network port show)
Node: n1

Ignore

Health
Port          IPspace      Broadcast Domain Link MTU  Admin/Oper  Status
Speed(Mbps)  Health
-----
-----
e0a          Cluster      Cluster      up    9000 auto/10000  -
-
e0b          Cluster      Cluster      up    9000 auto/10000  -
-
e0c          Cluster      Cluster      up    9000 auto/10000  -
-
e0d          Cluster      Cluster      up    9000 auto/10000  -
-

Node: n2

Ignore

Health
Port          IPspace      Broadcast Domain Link MTU  Admin/Oper  Status
Speed(Mbps)  Health
-----
-----
e0a          Cluster      Cluster      up    9000 auto/10000  -
-
e0b          Cluster      Cluster      up    9000 auto/10000  -
-
e0c          Cluster      Cluster      up    9000 auto/10000  -
-
e0d          Cluster      Cluster      up    9000 auto/10000  -
-

8 entries were displayed.

```

b. Display information about the logical interfaces:

```
network interface show
```

The following example displays the general information about all of the LIFs on your system:

```

cluster::*> network interface show -role cluster
(network interface show)

```

Current Is	Logical	Status	Network	Current
Vserver	Interface	Admin/Oper	Address/Mask	Node
Port	Home			

Cluster				
e0a	n1_clus1	up/up	10.10.0.1/24	n1
e0b	n1_clus2	up/up	10.10.0.2/24	n1
e0c	n1_clus3	up/up	10.10.0.3/24	n1
e0d	n1_clus4	up/up	10.10.0.4/24	n1
e0a	n2_clus1	up/up	10.10.0.5/24	n2
e0b	n2_clus2	up/up	10.10.0.6/24	n2
e0c	n2_clus3	up/up	10.10.0.7/24	n2
e0d	n2_clus4	up/up	10.10.0.8/24	n2

8 entries were displayed.

c. Display information about the discovered cluster switches:

```
system cluster-switch show
```

The following example displays the cluster switches that are known to the cluster, along with their management IP addresses:

```

cluster::*> system cluster-switch show

Switch                                         Type                                         Address
Model
-----
CL1                                           cluster-network                             10.10.1.101
NX5596
  Serial Number: 01234567
  Is Monitored: true
  Reason:
  Software Version: Cisco Nexus Operating System (NX-OS) Software,
Version
                                     7.1(1)N1(1)
  Version Source: CDP
CL2                                           cluster-network                             10.10.1.102
NX5596
  Serial Number: 01234568
  Is Monitored: true
  Reason:
  Software Version: Cisco Nexus Operating System (NX-OS) Software,
Version
                                     7.1(1)N1(1)
  Version Source: CDP

2 entries were displayed.

```

4. Set the `-auto-revert` parameter to `false` on cluster LIFs `clus1` and `clus2` on both nodes:

```
network interface modify
```

```

cluster::*> network interface modify -vserver node1 -lif clus1 -auto
-revert false
cluster::*> network interface modify -vserver node1 -lif clus2 -auto
-revert false
cluster::*> network interface modify -vserver node2 -lif clus1 -auto
-revert false
cluster::*> network interface modify -vserver node2 -lif clus2 -auto
-revert false

```

5. Verify that the appropriate RCF and image are installed on the new 3132Q-V switches as necessary for your requirements, and make the essential site customizations, such as users and passwords, network addresses, and so on.

You must prepare both switches at this time. If you need to upgrade the RCF and image, follow these

steps:

- a. Go to the [Cisco Ethernet Switches](#) page on the NetApp Support Site.
- b. Note your switch and the required software versions in the table on that page.
- c. Download the appropriate version of the RCF.
- d. Click **CONTINUE** on the **Description** page, accept the license agreement, and then follow the instructions on the **Download** page to download the RCF.
- e. Download the appropriate version of the image software.

See the *ONTAP 8.x or later Cluster and Management Network Switch Reference Configuration Files* Download page, and then click the appropriate version.

To find the correct version, see the *ONTAP 8.x or later Cluster Network Switch Download page*.

6. Migrate the LIFs associated with the second Nexus 5596 switch to be replaced:

```
network interface migrate
```

The following example shows n1 and n2, but LIF migration must be done on all of the nodes:

```
cluster::*> network interface migrate -vserver Cluster -lif n1_clus2
-source-node n1 -
destination-node n1 -destination-port e0a
cluster::*> network interface migrate -vserver Cluster -lif n1_clus3
-source-node n1 -
destination-node n1 -destination-port e0d
cluster::*> network interface migrate -vserver Cluster -lif n2_clus2
-source-node n2 -
destination-node n2 -destination-port e0a
cluster::*> network interface migrate -vserver Cluster -lif n2_clus3
-source-node n2 -
destination-node n2 -destination-port e0d
```

7. Verify the cluster's health:

```
network interface show
```

The following example shows the result of the previous `network interface migrate` command:

```

cluster::*> network interface show -role cluster
(network interface show)
      Logical      Status      Network      Current
Current Is
Vserver      Interface  Admin/Oper  Address/Mask  Node      Port
Home
-----
-----
Cluster
true         n1_clus1   up/up       10.10.0.1/24  n1        e0a
false        n1_clus2   up/up       10.10.0.2/24  n1        e0a
false        n1_clus3   up/up       10.10.0.3/24  n1        e0d
true         n1_clus4   up/up       10.10.0.4/24  n1        e0d
true         n2_clus1   up/up       10.10.0.5/24  n2        e0a
false        n2_clus2   up/up       10.10.0.6/24  n2        e0a
false        n2_clus3   up/up       10.10.0.7/24  n2        e0d
true         n2_clus4   up/up       10.10.0.8/24  n2        e0d
8 entries were displayed.

```

8. Shut down the cluster interconnect ports that are physically connected to switch CL2:

```
network port modify
```

The following commands shut down the specified ports on n1 and n2, but the ports must be shut down on all nodes:

```

cluster::*> network port modify -node n1 -port e0b -up-admin false
cluster::*> network port modify -node n1 -port e0c -up-admin false
cluster::*> network port modify -node n2 -port e0b -up-admin false
cluster::*> network port modify -node n2 -port e0c -up-admin false

```

9. Ping the remote cluster interfaces and perform an RPC server check:

```
cluster ping-cluster
```

The following example shows how to ping the remote cluster interfaces:

```

cluster::*> cluster ping-cluster -node n1
Host is n1
Getting addresses from network interface table...
Cluster n1_clus1 n1      e0a 10.10.0.1
Cluster n1_clus2 n1      e0b 10.10.0.2
Cluster n1_clus3 n1      e0c 10.10.0.3
Cluster n1_clus4 n1      e0d 10.10.0.4
Cluster n2_clus1 n2      e0a 10.10.0.5
Cluster n2_clus2 n2      e0b 10.10.0.6
Cluster n2_clus3 n2      e0c 10.10.0.7
Cluster n2_clus4 n2      e0d 10.10.0.8

Local = 10.10.0.1 10.10.0.2 10.10.0.3 10.10.0.4
Remote = 10.10.0.5 10.10.0.6 10.10.0.7 10.10.0.8
Cluster Vserver Id = 4294967293
Ping status:
....
Basic connectivity succeeds on 16 path(s)
Basic connectivity fails on 0 path(s)
.....
Detected 1500 byte MTU on 16 path(s):
  Local 10.10.0.1 to Remote 10.10.0.5
  Local 10.10.0.1 to Remote 10.10.0.6
  Local 10.10.0.1 to Remote 10.10.0.7
  Local 10.10.0.1 to Remote 10.10.0.8
  Local 10.10.0.2 to Remote 10.10.0.5
  Local 10.10.0.2 to Remote 10.10.0.6
  Local 10.10.0.2 to Remote 10.10.0.7
  Local 10.10.0.2 to Remote 10.10.0.8
  Local 10.10.0.3 to Remote 10.10.0.5
  Local 10.10.0.3 to Remote 10.10.0.6
  Local 10.10.0.3 to Remote 10.10.0.7
  Local 10.10.0.3 to Remote 10.10.0.8
  Local 10.10.0.4 to Remote 10.10.0.5
  Local 10.10.0.4 to Remote 10.10.0.6
  Local 10.10.0.4 to Remote 10.10.0.7
  Local 10.10.0.4 to Remote 10.10.0.8
Larger than PMTU communication succeeds on 16 path(s)
RPC status:
4 paths up, 0 paths down (tcp check)
4 paths up, 0 paths down (udp check)

```

10. Shut down the ISL ports 41 through 48 on the active Nexus 5596 switch CL1:

The following example shows how to shut down ISL ports 41 through 48 on the Nexus 5596 switch CL1:

```
(CL1)# configure
(CL1) (Config)# interface e1/41-48
(CL1) (config-if-range)# shutdown
(CL1) (config-if-range)# exit
(CL1) (Config)# exit
(CL1)#
```

If you are replacing a Nexus 5010 or 5020, specify the appropriate port numbers for ISL from page 1.

11. Build a temporary ISL between CL1 and C2.

The following example shows a temporary ISL being set up between CL1 and C2:

```
C2# configure
C2(config)# interface port-channel 2
C2(config-if)# switchport mode trunk
C2(config-if)# spanning-tree port type network
C2(config-if)# mtu 9216
C2(config-if)# interface breakout module 1 port 24 map 10g-4x
C2(config)# interface e1/24/1-4
C2(config-if-range)# switchport mode trunk
C2(config-if-range)# mtu 9216
C2(config-if-range)# channel-group 2 mode active
C2(config-if-range)# exit
C2(config-if)# exit
```

12. On all nodes, remove all cables attached to the Nexus 5596 switch CL2.

With supported cabling, reconnect disconnected ports on all nodes to the Nexus 3132Q-V switch C2.

13. Remove all the cables from the Nexus 5596 switch CL2.

Attach the appropriate Cisco QSFP to SFP+ break-out cables connecting port 1/24 on the new Cisco 3132Q-V switch, C2, to ports 45 to 48 on existing Nexus 5596, CL1.

14. Verify that interfaces eth1/45-48 already have channel-group 1 mode active in their running configuration.

15. Bring up ISLs ports 45 through 48 on the active Nexus 5596 switch CL1.

The following example shows ISLs ports 45 through 48 being brought up:

```
(CL1)# configure
(CL1) (Config)# interface e1/45-48
(CL1) (config-if-range)# no shutdown
(CL1) (config-if-range)# exit
(CL1) (Config)# exit
(CL1)#
```

16. Verify that the ISLs are up on the Nexus 5596 switch CL1:

```
show port-channel summary
```

Ports eth1/45 through eth1/48 should indicate (P) meaning that the ISL ports are up in the port-channel:

Example

```
CL1# show port-channel summary
```

```
Flags: D - Down          P - Up in port-channel (members)
       I - Individual    H - Hot-standby (LACP only)
       s - Suspended     r - Module-removed
       S - Switched     R - Routed
       U - Up (port-channel)
       M - Not in use. Min-links not met
```

```
-----
-----
Group Port-          Type   Protocol  Member Ports
Channel
-----
-----
1      Po1 (SU)      Eth    LACP      Eth1/41 (D)  Eth1/42 (D)  Eth1/43 (D)
                                   Eth1/44 (D)  Eth1/45 (P)  Eth1/46 (P)
                                   Eth1/47 (P)  Eth1/48 (P)
```

17. Verify that the ISLs are up on the 3132Q-V switch C2:

```
show port-channel summary
```

Ports eth1/24/1, eth1/24/2, eth1/24/3, and eth1/24/4 should indicate (P) meaning that the ISL ports are up in the port-channel:

```

C2# show port-channel summary
Flags: D - Down          P - Up in port-channel (members)
       I - Individual    H - Hot-standby (LACP only)
       s - Suspended     r - Module-removed
       S - Switched     R - Routed
       U - Up (port-channel)
       M - Not in use. Min-links not met
-----
-----
Group Port-          Type   Protocol  Member Ports
Channel
-----
-----
1      Po1(SU)        Eth    LACP      Eth1/31(D)  Eth1/32(D)
2      Po2(SU)        Eth    LACP      Eth1/24/1(P) Eth1/24/2(P)
Eth1/24/3(P)
                                     Eth1/24/4(P)

```

18. On all nodes, bring up all the cluster interconnect ports connected to the 3132Q-V switch C2:

```
network port modify
```

The following example shows the specified ports being brought up on nodes n1 and n2:

```

cluster::*> network port modify -node n1 -port e0b -up-admin true
cluster::*> network port modify -node n1 -port e0c -up-admin true
cluster::*> network port modify -node n2 -port e0b -up-admin true
cluster::*> network port modify -node n2 -port e0c -up-admin true

```

19. On all nodes, revert all of the migrated cluster interconnect LIFs connected to C2:

```
network interface revert
```

The following example shows the migrated cluster LIFs being reverted to their home ports on nodes n1 and n2:

```

cluster::*> network interface revert -vserver Cluster -lif n1_clus2
cluster::*> network interface revert -vserver Cluster -lif n1_clus3
cluster::*> network interface revert -vserver Cluster -lif n2_clus2
cluster::*> network interface revert -vserver Cluster -lif n2_clus3

```

20. Verify all the cluster interconnect ports are now reverted to their home:

```
network interface show
```

The following example shows that the LIFs on clus2 reverted to their home ports and shows that the LIFs are successfully reverted if the ports in the Current Port column have a status of `true` in the `Is Home` column. If the `Is Home` value is `false`, the LIF has not been reverted.

```

cluster::*> network interface show -role cluster
(network interface show)

```

Current Is	Logical	Status	Network	Current	
Vserver	Interface	Admin/Oper	Address/Mask	Node	Port
Home					
-----	-----	-----	-----	-----	-----
-----	-----	-----	-----	-----	-----
Cluster					
true	n1_clus1	up/up	10.10.0.1/24	n1	e0a
true	n1_clus2	up/up	10.10.0.2/24	n1	e0b
true	n1_clus3	up/up	10.10.0.3/24	n1	e0c
true	n1_clus4	up/up	10.10.0.4/24	n1	e0d
true	n2_clus1	up/up	10.10.0.5/24	n2	e0a
true	n2_clus2	up/up	10.10.0.6/24	n2	e0b
true	n2_clus3	up/up	10.10.0.7/24	n2	e0c
true	n2_clus4	up/up	10.10.0.8/24	n2	e0d

```

true
8 entries were displayed.

```

21. Verify that the clustered ports are connected:

```
network port show
```

The following example shows the result of the previous `network port modify` command, verifying that all the cluster interconnects are up:

```

cluster::*> network port show -role cluster
(network port show)
Node: n1

Ignore

Health
Port      IPspace      Broadcast Domain Link MTU  Admin/Oper  Status
Status
-----
-----
e0a      Cluster      Cluster      up    9000  auto/10000  -    -
e0b      Cluster      Cluster      up    9000  auto/10000  -    -
e0c      Cluster      Cluster      up    9000  auto/10000  -    -
e0d      Cluster      Cluster      up    9000  auto/10000  -    -

Node: n2

Ignore

Health
Port      IPspace      Broadcast Domain Link MTU  Admin/Oper  Status
Status
-----
-----
e0a      Cluster      Cluster      up    9000  auto/10000  -    -
e0b      Cluster      Cluster      up    9000  auto/10000  -    -
e0c      Cluster      Cluster      up    9000  auto/10000  -    -
e0d      Cluster      Cluster      up    9000  auto/10000  -    -
8 entries were displayed.

```

22. Ping the remote cluster interfaces and perform an RPC server check:

```
cluster ping-cluster
```

The following example shows how to ping the remote cluster interfaces:

```

cluster::*> cluster ping-cluster -node n1
Host is n1
Getting addresses from network interface table...
Cluster n1_clus1 n1      e0a 10.10.0.1
Cluster n1_clus2 n1      e0b 10.10.0.2
Cluster n1_clus3 n1      e0c 10.10.0.3
Cluster n1_clus4 n1      e0d 10.10.0.4
Cluster n2_clus1 n2      e0a 10.10.0.5
Cluster n2_clus2 n2      e0b 10.10.0.6
Cluster n2_clus3 n2      e0c 10.10.0.7
Cluster n2_clus4 n2      e0d 10.10.0.8

Local = 10.10.0.1 10.10.0.2 10.10.0.3 10.10.0.4
Remote = 10.10.0.5 10.10.0.6 10.10.0.7 10.10.0.8
Cluster Vserver Id = 4294967293
Ping status:
....
Basic connectivity succeeds on 16 path(s)
Basic connectivity fails on 0 path(s)
.....
Detected 1500 byte MTU on 16 path(s):
  Local 10.10.0.1 to Remote 10.10.0.5
  Local 10.10.0.1 to Remote 10.10.0.6
  Local 10.10.0.1 to Remote 10.10.0.7
  Local 10.10.0.1 to Remote 10.10.0.8
  Local 10.10.0.2 to Remote 10.10.0.5
  Local 10.10.0.2 to Remote 10.10.0.6
  Local 10.10.0.2 to Remote 10.10.0.7
  Local 10.10.0.2 to Remote 10.10.0.8
  Local 10.10.0.3 to Remote 10.10.0.5
  Local 10.10.0.3 to Remote 10.10.0.6
  Local 10.10.0.3 to Remote 10.10.0.7
  Local 10.10.0.3 to Remote 10.10.0.8
  Local 10.10.0.4 to Remote 10.10.0.5
  Local 10.10.0.4 to Remote 10.10.0.6
  Local 10.10.0.4 to Remote 10.10.0.7
  Local 10.10.0.4 to Remote 10.10.0.8
Larger than PMTU communication succeeds on 16 path(s)
RPC status:
4 paths up, 0 paths down (tcp check)
4 paths up, 0 paths down (udp check)

```

23. On each node in the cluster, migrate the interfaces associated with the first Nexus 5596 switch, CL1, to be replaced:

```
network interface migrate
```

The following example shows the ports or LIFs being migrated on nodes n1 and n2:

```
cluster::*> network interface migrate -vserver Cluster -lif n1_clus1
-source-node n1 -
destination-node n1 -destination-port e0b
cluster::*> network interface migrate -vserver Cluster -lif n1_clus4
-source-node n1 -
destination-node n1 -destination-port e0c
cluster::*> network interface migrate -vserver Cluster -lif n2_clus1
-source-node n2 -
destination-node n2 -destination-port e0b
cluster::*> network interface migrate -vserver Cluster -lif n2_clus4
-source-node n2 -
destination-node n2 -destination-port e0c
```

24. Verify the cluster status:

```
network interface show
```

The following example shows that the required cluster LIFs have been migrated to appropriate cluster ports hosted on cluster switch C2:

```
(network interface show)
      Logical   Status   Network   Current
Current Is
Vserver      Interface Admin/Oper Address/Mask   Node   Port
Home
-----
-----
Cluster
false        n1_clus1   up/up     10.10.0.1/24   n1     e0b
true         n1_clus2   up/up     10.10.0.2/24   n1     e0b
true         n1_clus3   up/up     10.10.0.3/24   n1     e0c
false        n1_clus4   up/up     10.10.0.4/24   n1     e0c
false        n2_clus1   up/up     10.10.0.5/24   n2     e0b
true         n2_clus2   up/up     10.10.0.6/24   n2     e0b
true         n2_clus3   up/up     10.10.0.7/24   n2     e0c
false        n2_clus4   up/up     10.10.0.8/24   n2     e0c
8 entries were displayed.
-----
```

25. On all the nodes, shut down the node ports that are connected to CL1:

```
network port modify
```

The following example shows the specified ports being shut down on nodes n1 and n2:

```
cluster::*> network port modify -node n1 -port e0a -up-admin false
cluster::*> network port modify -node n1 -port e0d -up-admin false
cluster::*> network port modify -node n2 -port e0a -up-admin false
cluster::*> network port modify -node n2 -port e0d -up-admin false
```

26. Shut down the ISL ports 24, 31, and 32 on the active 3132Q-V switch C2: shutdown

The following example shows how to shut down ISLs 24, 31, and 32:

```

C2# configure
C2(Config)# interface e1/24/1-4
C2(config-if-range)# shutdown
C2(config-if-range)# exit
C2(config)# interface 1/31-32
C2(config-if-range)# shutdown
C2(config-if-range)# exit
C2(config-if)# exit
C2#

```

27. On all nodes, remove all cables attached to the Nexus 5596 switch CL1.

With supported cabling, reconnect disconnected ports on all nodes to the Nexus 3132Q-V switch C1.

28. Remove the QSFP breakout cable from Nexus 3132Q-V C2 ports e1/24.

Connect ports e1/31 and e1/32 on C1 to ports e1/31 and e1/32 on C2 using supported Cisco QSFP optical fiber or direct-attach cables.

29. Restore the configuration on port 24 and remove the temporary Port Channel 2 on C2.

```

C2# configure
C2(config)# no interface breakout module 1 port 24 map 10g-4x
C2(config)# no interface port-channel 2
C2(config-if)# int e1/24
C2(config-if)# description 40GbE Node Port
C2(config-if)# spanning-tree port type edge
C2(config-if)# spanning-tree bpduguard enable
C2(config-if)# mtu 9216
C2(config-if-range)# exit
C2(config)# exit
C2# copy running-config startup-config
[#####] 100%
Copy Complete.

```

30. Bring up ISL ports 31 and 32 on C2, the active 3132Q-V switch: no shutdown

The following example shows how to bring up ISLs 31 and 32 on the 3132Q-V switch C2:

```

C2# configure
C2(config)# interface ethernet 1/31-32
C2(config-if-range)# no shutdown
C2(config-if-range)# exit
C2(config)# exit
C2# copy running-config startup-config
[#####] 100%
Copy Complete.

```

31. Verify that the ISL connections are up on the 3132Q-V switch C2: show port-channel summary

Ports Eth1/31 and Eth1/32 should indicate (P), meaning that both the ISL ports are up in the port-channel:

```

C1# show port-channel summary
Flags: D - Down          P - Up in port-channel (members)
       I - Individual    H - Hot-standby (LACP only)
       s - Suspended     r - Module-removed
       S - Switched     R - Routed
       U - Up (port-channel)
       M - Not in use. Min-links not met
-----
-----
Group Port-          Type   Protocol  Member Ports
  Channel
-----
-----
1      Po1(SU)       Eth     LACP      Eth1/31(P)  Eth1/32(P)

```

32. On all nodes, bring up all the cluster interconnect ports connected to the new 3132Q-V switch C1:

```
network port modify
```

The following example shows all the cluster interconnect ports being brought up for n1 and n2 on the 3132Q-V switch C1:

```

cluster::*> network port modify -node n1 -port e0a -up-admin true
cluster::*> network port modify -node n1 -port e0d -up-admin true
cluster::*> network port modify -node n2 -port e0a -up-admin true
cluster::*> network port modify -node n2 -port e0d -up-admin true

```

33. Verify the status of the cluster node port: network port show

The following example verifies that all cluster interconnect ports on all nodes on the new 3132Q-V switch C1 are up:

```

cluster::*> network port show -role cluster
(network port show)
Node: n1

Ignore

Health
Port          IPspace      Broadcast Domain Link MTU  Admin/Oper  Status
Speed(Mbps)  Health
Status
-----
-----
e0a           Cluster      Cluster      up    9000  auto/10000  -    -
e0b           Cluster      Cluster      up    9000  auto/10000  -    -
e0c           Cluster      Cluster      up    9000  auto/10000  -    -
e0d           Cluster      Cluster      up    9000  auto/10000  -    -

Node: n2

Ignore

Health
Port          IPspace      Broadcast Domain Link MTU  Admin/Oper  Status
Speed(Mbps)  Health
Status
-----
-----
e0a           Cluster      Cluster      up    9000  auto/10000  -    -
e0b           Cluster      Cluster      up    9000  auto/10000  -    -
e0c           Cluster      Cluster      up    9000  auto/10000  -    -
e0d           Cluster      Cluster      up    9000  auto/10000  -    -
8 entries were displayed.

```

34. On all nodes, revert the specific cluster LIFs to their home ports:

```
network interface revert
```

The following example shows the specific cluster LIFs being reverted to their home ports on nodes n1 and n2:

```

cluster::*> network interface revert -vserver Cluster -lif n1_clus1
cluster::*> network interface revert -vserver Cluster -lif n1_clus4
cluster::*> network interface revert -vserver Cluster -lif n2_clus1
cluster::*> network interface revert -vserver Cluster -lif n2_clus4

```

35. Verify that the interface is home:

```
network interface show
```

The following example shows the status of cluster interconnect interfaces is up and Is home for n1 and n2:

```
cluster::*> network interface show -role cluster
(network interface show)
Current Is
Vserver Logical Status Network Current
Home Interface Admin/Oper Address/Mask Node Port
-----
-----
Cluster
true n1_clus1 up/up 10.10.0.1/24 n1 e0a
true n1_clus2 up/up 10.10.0.2/24 n1 e0b
true n1_clus3 up/up 10.10.0.3/24 n1 e0c
true n1_clus4 up/up 10.10.0.4/24 n1 e0d
true n2_clus1 up/up 10.10.0.5/24 n2 e0a
true n2_clus2 up/up 10.10.0.6/24 n2 e0b
true n2_clus3 up/up 10.10.0.7/24 n2 e0c
true n2_clus4 up/up 10.10.0.8/24 n2 e0d
true
8 entries were displayed.
```

36. Ping the remote cluster interfaces and then perform a remote procedure call server check:

```
cluster ping-cluster
```

The following example shows how to ping the remote cluster interfaces:

```

cluster::*> cluster ping-cluster -node n1
Host is n1
Getting addresses from network interface table...
Cluster n1_clus1 n1      e0a 10.10.0.1
Cluster n1_clus2 n1      e0b 10.10.0.2
Cluster n1_clus3 n1      e0c 10.10.0.3
Cluster n1_clus4 n1      e0d 10.10.0.4
Cluster n2_clus1 n2      e0a 10.10.0.5
Cluster n2_clus2 n2      e0b 10.10.0.6
Cluster n2_clus3 n2      e0c 10.10.0.7
Cluster n2_clus4 n2      e0d 10.10.0.8

Local = 10.10.0.1 10.10.0.2 10.10.0.3 10.10.0.4
Remote = 10.10.0.5 10.10.0.6 10.10.0.7 10.10.0.8
Cluster Vserver Id = 4294967293
Ping status:
....
Basic connectivity succeeds on 16 path(s)
Basic connectivity fails on 0 path(s)
.....
Detected 1500 byte MTU on 16 path(s):
  Local 10.10.0.1 to Remote 10.10.0.5
  Local 10.10.0.1 to Remote 10.10.0.6
  Local 10.10.0.1 to Remote 10.10.0.7
  Local 10.10.0.1 to Remote 10.10.0.8
  Local 10.10.0.2 to Remote 10.10.0.5
  Local 10.10.0.2 to Remote 10.10.0.6
  Local 10.10.0.2 to Remote 10.10.0.7
  Local 10.10.0.2 to Remote 10.10.0.8
  Local 10.10.0.3 to Remote 10.10.0.5
  Local 10.10.0.3 to Remote 10.10.0.6
  Local 10.10.0.3 to Remote 10.10.0.7
  Local 10.10.0.3 to Remote 10.10.0.8
  Local 10.10.0.4 to Remote 10.10.0.5
  Local 10.10.0.4 to Remote 10.10.0.6
  Local 10.10.0.4 to Remote 10.10.0.7
  Local 10.10.0.4 to Remote 10.10.0.8
Larger than PMTU communication succeeds on 16 path(s)
RPC status:
4 paths up, 0 paths down (tcp check)
4 paths up, 0 paths down (udp check)

```

37. Expand the cluster by adding nodes to the Nexus 3132Q-V cluster switches.
38. Display the information about the devices in your configuration:

- network device-discovery show
- network port show -role cluster
- network interface show -role cluster
- system cluster-switch show

The following examples show nodes n3 and n4 with 40 GbE cluster ports connected to ports e1/7 and e1/8, respectively on both the Nexus 3132Q-V cluster switches, and both nodes have joined the cluster. The 40 GbE cluster interconnect ports used are e4a and e4e.

```
cluster::> network device-discovery show
```

Node	Local Port	Discovered Device	Interface	Platform
n1	/cdp			
	e0a	C1	Ethernet1/1/1	N3K-C3132Q-V
	e0b	C2	Ethernet1/1/1	N3K-C3132Q-V
	e0c	C2	Ethernet1/1/2	N3K-C3132Q-V
n2	/cdp			
	e0d	C1	Ethernet1/1/2	N3K-C3132Q-V
	e0a	C1	Ethernet1/1/3	N3K-C3132Q-V
	e0b	C2	Ethernet1/1/3	N3K-C3132Q-V
n3	e0c	C2	Ethernet1/1/4	N3K-C3132Q-V
	e0d	C1	Ethernet1/1/4	N3K-C3132Q-V
	/cdp			
n3	e4a	C1	Ethernet1/7	N3K-C3132Q-V
	e4e	C2	Ethernet1/7	N3K-C3132Q-V
n4	/cdp			
	e4a	C1	Ethernet1/8	N3K-C3132Q-V
	e4e	C2	Ethernet1/8	N3K-C3132Q-V

12 entries were displayed.

```
cluster::*> network port show -role cluster
(network port show)
Node: n1

Ignore

Health
Speed(Mbps) Health
Port IPspace Broadcast Domain Link MTU Admin/Oper Status
Status
-----
```

Port	IPspace	Broadcast Domain	Link	MTU	Admin/Oper	Status
e0a	Cluster	Cluster	up	9000	auto/10000	-
-						

```

e0b      Cluster      Cluster      up    9000 auto/10000 -
-
e0c      Cluster      Cluster      up    9000 auto/10000 -
-
e0d      Cluster      Cluster      up    9000 auto/10000 -
-

```

Node: n2

Ignore

```

                                          Speed(Mbps) Health
Health
Port      IPspace      Broadcast Domain Link MTU  Admin/Oper  Status
Status
-----
-----

```

```

e0a      Cluster      Cluster      up    9000 auto/10000 -
-
e0b      Cluster      Cluster      up    9000 auto/10000 -
-
e0c      Cluster      Cluster      up    9000 auto/10000 -
-
e0d      Cluster      Cluster      up    9000 auto/10000 -
-

```

Node: n3

Ignore

```

                                          Speed(Mbps) Health
Health
Port      IPspace      Broadcast Domain Link MTU  Admin/Oper  Status
Status
-----
-----

```

```

e4a      Cluster      Cluster      up    9000 auto/40000 -
-
e4e      Cluster      Cluster      up    9000 auto/40000 -
-

```

Node: n4

Ignore

```

                                          Speed(Mbps) Health
Health
Port      IPspace      Broadcast Domain Link MTU  Admin/Oper  Status
Status
-----
-----

```

```

-----
-----
e4a      Cluster      Cluster      up    9000 auto/40000 -
-

```

```

e4e      Cluster      Cluster      up    9000 auto/40000 -
-

```

12 entries were displayed.

```

cluster::*> network interface show -role cluster
(network interface show)

```

Current Is	Logical Interface	Status Admin/Oper	Network Address/Mask	Current Node	
	Cluster				
e0a	true	n1_clus1	up/up	10.10.0.1/24	n1
e0b	true	n1_clus2	up/up	10.10.0.2/24	n1
e0c	true	n1_clus3	up/up	10.10.0.3/24	n1
e0d	true	n1_clus4	up/up	10.10.0.4/24	n1
e0a	true	n2_clus1	up/up	10.10.0.5/24	n2
e0b	true	n2_clus2	up/up	10.10.0.6/24	n2
e0c	true	n2_clus3	up/up	10.10.0.7/24	n2
e0d	true	n2_clus4	up/up	10.10.0.8/24	n2
e4a	true	n3_clus1	up/up	10.10.0.9/24	n3
e4e	true	n3_clus2	up/up	10.10.0.10/24	n3
e4a	true	n4_clus1	up/up	10.10.0.11/24	n4
e4e	true	n4_clus2	up/up	10.10.0.12/24	n4

12 entries were displayed.

```
cluster::*> system cluster-switch show
```

Switch	Type	Address	Model

C1	cluster-network	10.10.1.103	NX3132V
Serial Number: FOX000001			
Is Monitored: true			
Reason:			
Software Version: Cisco Nexus Operating System (NX-OS) Software,			
Version			
7.0(3)I4(1)			
Version Source: CDP			
C2	cluster-network	10.10.1.104	NX3132V
Serial Number: FOX000002			
Is Monitored: true			
Reason:			
Software Version: Cisco Nexus Operating System (NX-OS) Software,			
Version			
7.0(3)I4(1)			
Version Source: CDP			
CL1	cluster-network	10.10.1.101	NX5596
Serial Number: 01234567			
Is Monitored: true			
Reason:			
Software Version: Cisco Nexus Operating System (NX-OS) Software,			
Version			
7.1(1)N1(1)			
Version Source: CDP			
CL2	cluster-network	10.10.1.102	NX5596
Serial Number: 01234568			
Is Monitored: true			
Reason:			
Software Version: Cisco Nexus Operating System (NX-OS) Software,			
Version			
7.1(1)N1(1)			
Version Source: CDP			

4 entries were displayed.

39. Remove the replaced Nexus 5596 if they are not automatically removed: system cluster-switch delete

The following example shows how to remove the Nexus 5596:

```
cluster::> system cluster-switch delete -device CL1
cluster::> system cluster-switch delete -device CL2
```

40. Configure clusters clus1 and clus2 to auto revert on each node and confirm:

```
cluster::*> network interface modify -vserver node1 -lif clus1 -auto
-revert true
cluster::*> network interface modify -vserver node1 -lif clus2 -auto
-revert true
cluster::*> network interface modify -vserver node2 -lif clus1 -auto
-revert true
cluster::*> network interface modify -vserver node2 -lif clus2 -auto
-revert true
```

41. Verify that the proper cluster switches are monitored: `system cluster-switch show`

```
cluster::> system cluster-switch show
```

Switch	Type	Address	Model
C1	cluster-network	10.10.1.103	NX3132V
Serial Number: FOX000001			
Is Monitored: true			
Reason:			
Software Version: Cisco Nexus Operating System (NX-OS) Software,			
Version			
7.0(3)I4(1)			
Version Source: CDP			
C2	cluster-network	10.10.1.104	NX3132V
Serial Number: FOX000002			
Is Monitored: true			
Reason:			
Software Version: Cisco Nexus Operating System (NX-OS) Software,			
Version			
7.0(3)I4(1)			
Version Source: CDP			

2 entries were displayed.

42. Enable the cluster switch health monitor log collection feature for collecting switch-related log files:

```
system cluster-switch log setup-password  
  
system cluster-switch log enable-collection
```

```
cluster::*> system cluster-switch log setup-password  
Enter the switch name: <return>  
The switch name entered is not recognized.  
Choose from the following list:  
C1  
C2  
  
cluster::*> system cluster-switch log setup-password  
  
Enter the switch name: C1  
**RSA key fingerprint is e5:8b:c6:dc:e2:18:18:09:36:63:d9:63:dd:03:d9:cc  
Do you want to continue? {y|n}::[n] y  
  
Enter the password: <enter switch password>  
Enter the password again: <enter switch password>  
  
cluster::*> system cluster-switch log setup-password  
  
Enter the switch name: C2  
RSA key fingerprint is 57:49:86:a1:b9:80:6a:61:9a:86:8e:3c:e3:b7:1f:b1  
Do you want to continue? {y|n}:: [n] y  
  
Enter the password: <enter switch password>  
Enter the password again: <enter switch password>  
  
cluster::*> system cluster-switch log enable-collection  
  
Do you want to enable cluster log collection for all nodes in the  
cluster?  
{y|n}: [n] y  
  
Enabling cluster switch log collection.  
  
cluster::*>
```



If any of these commands return an error, contact NetApp support.

43. If you suppressed automatic case creation, reenable it by invoking an AutoSupport message:

```
system node autosupport invoke -node * -type all -message MAINT=END
```

Related information

[Cisco Ethernet Switch description page](#)

[Hardware Universe](#)

Replace CN1610 cluster switches with Cisco Nexus 3132Q-V cluster switches

You must be aware of certain configuration information, port connections, and cabling requirements when you replace CN1610 cluster switches with Cisco Nexus 3132Q-V cluster switches.

- The following cluster switches are supported:
 - NetApp CN1610
 - Cisco Nexus 3132Q-V
- The cluster switches support the following node connections:
 - NetApp CN1610: ports 0/1 through 0/12 (10 GbE)
 - Cisco Nexus 3132Q-V: ports e1/1-30 (40/100 GbE)
- The cluster switches use the following inter-switch link (ISL) ports:
 - NetApp CN1610: ports 0/13 through 0/16 (10 GbE)
 - Cisco Nexus 3132Q-V: ports e1/31-32 (40/100 GbE)
- The [Hardware Universe](#) contains information about supported cabling to Nexus 3132Q-V switches:
 - Nodes with 10 GbE cluster connections require QSFP to SFP+ optical fiber breakout cables or QSFP to SFP+ copper breakout cables
 - Nodes with 40/100 GbE cluster connections require supported QSFP/QSFP28 optical modules with optical fiber cables or QSFP/QSFP28 copper direct-attach cables
- The appropriate ISL cabling is as follows:
 - Beginning: For CN1610 to CN1610 (SFP+ to SFP+), four SFP+ optical fiber or copper direct-attach cables
 - Interim: For CN1610 to Nexus 3132Q-V (QSFP to four SFP+ breakout), one QSFP to SFP+ optical fiber or copper breakout cable
 - Final: For Nexus 3132Q-V to Nexus 3132Q-V (QSFP28 to QSFP28), two QSFP28 optical fiber or copper direct-attach cables
- NetApp twinax cables are not compatible with Cisco Nexus 3132Q-V switches.

If your current CN1610 configuration uses NetApp twinax cables for cluster-node-to-switch connections or ISL connections and you want to continue using twinax in your environment, you need to procure Cisco twinax cables. Alternatively, you can use optical fiber cables for both the ISL connections and the cluster-node-to-switch connections.

- On Nexus 3132Q-V switches, you can operate QSFP/QSFP28 ports as either 40/100 Gb Ethernet or 4x 10 Gb Ethernet modes.

By default, there are 32 ports in the 40/100 Gb Ethernet mode. These 40 Gb Ethernet ports are numbered

in a 2-tuple naming convention. For example, the second 40 Gb Ethernet port is numbered as 1/2. The process of changing the configuration from 40 Gb Ethernet to 10 Gb Ethernet is called *breakout* and the process of changing the configuration from 10 Gb Ethernet to 40 Gb Ethernet is called *breakin*. When you break out a 40/100 Gb Ethernet port into 10 Gb Ethernet ports, the resulting ports are numbered using a 3-tuple naming convention. For example, the breakout ports of the second 40 Gb Ethernet port are numbered as 1/2/1, 1/2/2, 1/2/3, and 1/2/4.

- On the left side of Nexus 3132Q-V switches is a set of four SFP+ ports multiplexed to the first QSFP port.

By default, the reference configuration file (RCF) is structured to use the first QSFP port.

You can make four SFP+ ports active instead of a QSFP port for Nexus 3132Q-V switches by using the `hardware profile front portmode sfp-plus` command. Similarly, you can reset Nexus 3132Q-V switches to use a QSFP port instead of four SFP+ ports by using the `hardware profile front portmode qsfp` command.



When you use the first four SFP+ ports, it will disable the first 40GbE QSFP port.

- You must have configured some of the ports on Nexus 3132Q-V switches to run at 10 GbE or 40/100 GbE.

You can break out the first six ports into 4x 10 GbE mode by using the `interface breakout module 1 port 1-6 map 10g-4x` command. Similarly, you can regroup the first six QSFP+ ports from *breakout* configuration by using the `no interface breakout module 1 port 1-6 map 10g-4x` command.

- You must have done the planning, migration, and read the required documentation on 10 GbE and 40/100 GbE connectivity from nodes to Nexus 3132Q-V cluster switches.
- The ONTAP and NX-OS versions that are supported in this procedure are listed on the [Cisco Ethernet Switches](#) page.
- The ONTAP and FASTPATH versions that are supported in this procedure are listed on the [NetApp CN1601 and CN1610 Switches](#) page.

How to replace CN1610 cluster switches with Cisco Nexus 3132Q-V cluster switches

To replace the existing CN1610 cluster switches in a cluster with Cisco Nexus 3132Q-V cluster switches, you must perform a specific sequence of tasks.

About this task

The examples in this procedure use four nodes: Two nodes use four 10 GbE cluster interconnect ports: e0a, e0b, e0c, and e0d. The other two nodes use two 40/100 GbE cluster interconnect fiber cables: e4a and e4e. The [Hardware Universe](#) has information about the cluster fiber cables on your platforms.

The examples in this procedure use the following switch and node nomenclature:

- The command outputs might vary depending on different releases of ONTAP software.
- The CN1610 switches to be replaced are CL1 and CL2.
- The Nexus 3132Q-V switches to replace the CN1610 switches are C1 and C2.
- n1_clus1 is the first cluster logical interface (LIF) that is connected to cluster switch 1 (CL1 or C1) for node n1.
- n1_clus2 is the first cluster LIF that is connected to cluster switch 2 (CL2 or C2) for node n1.

- n1_clus3 is the second LIF that is connected to cluster switch 2 (CL2 or C2) for node n1.
- n1_clus4 is the second LIF that is connected to cluster switch 1 (CL1 or C1) for node n1. The nodes are n1, n2, n3, and n4.
- The number of 10 GbE and 40/100 GbE ports are defined in the reference configuration files (RCFs) available on the [Cisco® Cluster Network Switch Reference Configuration File Download](#) page.

This procedure covers the following scenario:

- The cluster starts with two nodes connected to two CN1610 cluster switches.
- Cluster switch CL2 to be replaced by C2 ([Steps 2 - 22](#))
 - Traffic on all cluster ports and LIFs on all nodes connected to CL2 are migrated onto the first cluster ports and LIFs connected to CL1.
 - Disconnect cabling from all cluster ports on all nodes connected to CL2, and then use supported breakout cabling to reconnect the ports to new cluster switch C2.
 - Disconnect cabling between ISL ports CL1 and CL2, and then use supported breakout cabling to reconnect the ports from CL1 to C2.
 - Traffic on all cluster ports and LIFs connected to C2 on all nodes is reverted.
- Cluster switch CL1 to be replaced by C1 ([Steps 23 - 43](#))
 - Traffic on all cluster ports and LIFs on all nodes connected to CL1 are migrated onto the second cluster ports and LIFs connected to C2.
 - Disconnect cabling from all cluster ports on all nodes connected to CL1, and then use supported breakout cabling to reconnect the ports to new cluster switch C1.
 - Disconnect cabling between ISL ports CL1 and C2, and then use supported breakout cabling to reconnect the ports from C1 to C2.
 - Traffic on all migrated cluster ports and LIFs connected to C1 on all nodes is reverted.



The procedure requires the use of both ONTAP commands and Cisco Nexus 3000 Series Switches commands; ONTAP commands are used unless otherwise indicated.

Steps

1. If AutoSupport is enabled on this cluster, suppress automatic case creation by invoking an AutoSupport message:

```
system node autosupport invoke -node * -type all - message MAINT=xh
```

x is the duration of the maintenance window in hours.



The AutoSupport message notifies technical support of this maintenance task so that automatic case creation is suppressed during the maintenance window.

2. Display information about the devices in your configuration: `network device-discovery show`

The following example displays how many cluster interconnect interfaces have been configured in each node for each cluster interconnect switch:

```
cluster::> network device-discovery show
```

Node	Local Port	Discovered Device	Interface	Platform
n1	/cdp			
	e0a	CL1	0/1	CN1610
	e0b	CL2	0/1	CN1610
	e0c	CL2	0/2	CN1610
	e0d	CL1	0/2	CN1610
n2	/cdp			
	e0a	CL1	0/3	CN1610
	e0b	CL2	0/3	CN1610
	e0c	CL2	0/4	CN1610
	e0d	CL1	0/4	CN1610

```
8 entries were displayed.
```

3. Determine the administrative or operational status for each cluster interface.

a. Display the cluster network port attributes: `network port show`

The following example displays the network port attributes on a system:

```

cluster::*> network port show -role cluster
(network port show)

Node: n1

Port  IPspace  Broadcast  Link  MTU  Speed (Mbps)  Health  Ignore
Status  Domain
-----  -----  -----  -----  -----  -----  -----  -----
e0a   cluster  cluster    up    9000  auto/10000    -       -
e0b   cluster  cluster    up    9000  auto/10000    -       -
e0c   cluster  cluster    up    9000  auto/10000    -       -
e0d   cluster  cluster    up    9000  auto/10000    -       -

Node: n2

Port  IPspace  Broadcast  Link  MTU  Speed (Mbps)  Health  Ignore
Status  Domain
-----  -----  -----  -----  -----  -----  -----  -----
e0a   cluster  cluster    up    9000  auto/10000    -       -
e0b   cluster  cluster    up    9000  auto/10000    -       -
e0c   cluster  cluster    up    9000  auto/10000    -       -
e0d   cluster  cluster    up    9000  auto/10000    -       -

8 entries were displayed.

```

b. Display information about the logical interfaces: `network interface show`

The following example displays the general information about all of the LIFs on your system:

```
cluster::*> network interface show -role cluster
(network interface show)
```

Vserver	Logical Interface	Status Admin/Oper	Network Address/Mask	Current Node	Current Port	Is Home
Cluster						
	n1_clus1	up/up	10.10.0.1/24	n1	e0a	true
	n1_clus2	up/up	10.10.0.2/24	n1	e0b	true
	n1_clus3	up/up	10.10.0.3/24	n1	e0c	true
	n1_clus4	up/up	10.10.0.4/24	n1	e0d	true
	n2_clus1	up/up	10.10.0.5/24	n2	e0a	true
	n2_clus2	up/up	10.10.0.6/24	n2	e0b	true
	n2_clus3	up/up	10.10.0.7/24	n2	e0c	true
	n2_clus4	up/up	10.10.0.8/24	n2	e0d	true

8 entries were displayed.

c. Display information about the discovered cluster switches: `system cluster-switch show`

The following example displays the cluster switches that are known to the cluster, along with their management IP addresses:

```
cluster::*> system cluster-switch show
```

Switch	Type	Address	Model
CL1	cluster-network	10.10.1.101	CN1610
Serial Number: 01234567			
Is Monitored: true			
Reason:			
Software Version: 1.2.0.7			
Version Source: ISDP			
CL2	cluster-network	10.10.1.102	CN1610
Serial Number: 01234568			
Is Monitored: true			
Reason:			
Software Version: 1.2.0.7			
Version Source: ISDP			

2 entries were displayed.

4. Set the `-auto-revert` parameter to false on cluster LIFs `clus1` and `clus4` on both nodes: `network interface modify`

```
cluster::*> network interface modify -vserver node1 -lif clus1 -auto
-revert false
cluster::*> network interface modify -vserver node1 -lif clus4 -auto
-revert false
cluster::*> network interface modify -vserver node2 -lif clus1 -auto
-revert false
cluster::*> network interface modify -vserver node2 -lif clus4 -auto
-revert false
```

5. Verify that the appropriate RCF and image are installed on the new 3132Q-V switches as necessary for your requirements, and make any essential site customizations, such as users and passwords, network addresses, and so on.

You must prepare both switches at this time. If you need to upgrade the RCF and image, follow these steps:

- See the [Cisco Ethernet Switches](#) page on NetApp Support Site.
- Note your switch and the required software versions in the table on that page.
- Download the appropriate version of the RCF.
- Click **CONTINUE** on the **Description** page, accept the license agreement, and then follow the instructions on the **Download** page to download the RCF.
- Download the appropriate version of the image software.

[Cisco® Cluster and Management Network Switch Reference Configuration File Download](#)

6. Migrate the LIFs associated with the second CN1610 switch to be replaced: `network interface migrate`



You must migrate the cluster LIFs from a connection to the node, either through the service processor or node management interface, which owns the cluster LIF being migrated.

The following example shows `n1` and `n2`, but LIF migration must be done on all the nodes:

```
cluster::*> network interface migrate -vserver Cluster -lif n1_clus2
-destination-node n1 -destination-port e0a
cluster::*> network interface migrate -vserver Cluster -lif n1_clus3
-destination-node n1 -destination-port e0d
cluster::*> network interface migrate -vserver Cluster -lif n2_clus2
-destination-node n2 -destination-port e0a
cluster::*> network interface migrate -vserver Cluster -lif n2_clus3
-destination-node n2 -destination-port e0d
```

7. Verify the cluster's health: `network interface show`

The following example shows the result of the previous `network interface migrate` command:

```
cluster::*> network interface show -role cluster
(network interface show)
```

Vserver	Logical Interface	Status Admin/Oper	Network Address/Mask	Current Node	Current Port	Is Home
Cluster	n1_clus1	up/up	10.10.0.1/24	n1	e0a	true
	n1_clus2	up/up	10.10.0.2/24	n1	e0a	false
	n1_clus3	up/up	10.10.0.3/24	n1	e0d	false
	n1_clus4	up/up	10.10.0.4/24	n1	e0d	true
	n2_clus1	up/up	10.10.0.5/24	n2	e0a	true
	n2_clus2	up/up	10.10.0.6/24	n2	e0a	false
	n2_clus3	up/up	10.10.0.7/24	n2	e0d	false
	n2_clus4	up/up	10.10.0.8/24	n2	e0d	true

8 entries were displayed.

8. Shut down the cluster interconnect ports that are physically connected to switch CL2: `network port modify`

The following commands shut down the specified ports on n1 and n2, but the ports must be shut down on all nodes:

```
cluster::*> network port modify -node n1 -port e0b -up-admin false
cluster::*> network port modify -node n1 -port e0c -up-admin false
cluster::*> network port modify -node n2 -port e0b -up-admin false
cluster::*> network port modify -node n2 -port e0c -up-admin false
```

9. Ping the remote cluster interfaces, and then perform a remote procedure call server check: `cluster ping-cluster`

The following example shows how to ping the remote cluster interfaces:

```

cluster::*> cluster ping-cluster -node n1
Host is n1
Getting addresses from network interface table...
Cluster n1_clus1 n1      e0a    10.10.0.1
Cluster n1_clus2 n1      e0b    10.10.0.2
Cluster n1_clus3 n1      e0c    10.10.0.3
Cluster n1_clus4 n1      e0d    10.10.0.4
Cluster n2_clus1 n2      e0a    10.10.0.5
Cluster n2_clus2 n2      e0b    10.10.0.6
Cluster n2_clus3 n2      e0c    10.10.0.7
Cluster n2_clus4 n2      e0d    10.10.0.8

Local = 10.10.0.1 10.10.0.2 10.10.0.3 10.10.0.4
Remote = 10.10.0.5 10.10.0.6 10.10.0.7 10.10.0.8
Cluster Vserver Id = 4294967293
Ping status:
....
Basic connectivity succeeds on 16 path(s)
Basic connectivity fails on 0 path(s)
.....
Detected 1500 byte MTU on 16 path(s):
  Local 10.10.0.1 to Remote 10.10.0.5
  Local 10.10.0.1 to Remote 10.10.0.6
  Local 10.10.0.1 to Remote 10.10.0.7
  Local 10.10.0.1 to Remote 10.10.0.8
  Local 10.10.0.2 to Remote 10.10.0.5
  Local 10.10.0.2 to Remote 10.10.0.6
  Local 10.10.0.2 to Remote 10.10.0.7
  Local 10.10.0.2 to Remote 10.10.0.8
  Local 10.10.0.3 to Remote 10.10.0.5
  Local 10.10.0.3 to Remote 10.10.0.6
  Local 10.10.0.3 to Remote 10.10.0.7
  Local 10.10.0.3 to Remote 10.10.0.8
  Local 10.10.0.4 to Remote 10.10.0.5
  Local 10.10.0.4 to Remote 10.10.0.6
  Local 10.10.0.4 to Remote 10.10.0.7
  Local 10.10.0.4 to Remote 10.10.0.8

Larger than PMTU communication succeeds on 16 path(s)
RPC status:
4 paths up, 0 paths down (tcp check)
4 paths up, 0 paths down (udp check)

```

10. Shut down the ISL ports 13 through 16 on the active CN1610 switch CL1: shutdown

The following example shows how to shut down ISL ports 13 through 16 on the CN1610 switch CL1:

```
(CL1)# configure
(CL1)(Config)# interface 0/13-0/16
(CL1)(Interface 0/13-0/16)# shutdown
(CL1)(Interface 0/13-0/16)# exit
(CL1)(Config)# exit
(CL1)#
```

11. Build a temporary ISL between CL1 and C2:

The following example builds a temporary ISL between CL1 (ports 13-16) and C2 (ports e1/24/1-4):

```
C2# configure
C2(config)# interface port-channel 2
C2(config-if)# switchport mode trunk
C2(config-if)# spanning-tree port type network
C2(config-if)# mtu 9216
C2(config-if)# interface breakout module 1 port 24 map 10g-4x
C2(config)# interface e1/24/1-4
C2(config-if-range)# switchport mode trunk
C2(config-if-range)# mtu 9216
C2(config-if-range)# channel-group 2 mode active
C2(config-if-range)# exit
C2(config-if)# exit
```

12. On all nodes, remove the cables that are attached to the CN1610 switch CL2.

With supported cabling, you must reconnect the disconnected ports on all of the nodes to the Nexus 3132Q-V switch C2.

13. Remove four ISL cables from ports 13 to 16 on the CN1610 switch CL1.

You must attach appropriate Cisco QSFP to SFP+ breakout cables connecting port 1/24 on the new Cisco 3132Q-V switch C2, to ports 13 to 16 on existing CN1610 switch CL1.



When reconnecting any cables to the new Cisco 3132Q-V switch, you must use either optical fiber or Cisco twinax cables.

14. To make the ISL dynamic, configure the ISL interface 3/1 on the active CN1610 switch to disable the static mode: `no port-channel static`

This configuration matches with the ISL configuration on the 3132Q-V switch C2 when the ISLs are brought up on both switches in step 11

The following example shows the configuration of the ISL interface 3/1 using the `no port-channel static` command to make the ISL dynamic:

```
(CL1)# configure
(CL1) (Config)# interface 3/1
(CL1) (Interface 3/1)# no port-channel static
(CL1) (Interface 3/1)# exit
(CL1) (Config)# exit
(CL1)#
```

15. Bring up ISLs 13 through 16 on the active CN1610 switch CL1.

The following example illustrates the process of bringing up ISL ports 13 through 16 on the port-channel interface 3/1:

```
(CL1)# configure
(CL1) (Config)# interface 0/13-0/16,3/1
(CL1) (Interface 0/13-0/16,3/1)# no shutdown
(CL1) (Interface 0/13-0/16,3/1)# exit
(CL1) (Config)# exit
(CL1)#
```

16. Verify that the ISLs are up on the CN1610 switch CL1: show port-channel

The "Link State" should be Up, "Type" should be Dynamic, and the "Port Active" column should be True for ports 0/13 to 0/16:

```
(CL1)# show port-channel 3/1
Local Interface..... 3/1
Channel Name..... ISL-LAG
Link State..... Up
Admin Mode..... Enabled
Type..... Dynamic
Load Balance Option..... 7
(Enhanced hashing mode)

Mbr      Device/      Port      Port
Ports   Timeout     Speed     Active
-----
0/13     actor/long   10 Gb Full  True
         partner/long
0/14     actor/long   10 Gb Full  True
         partner/long
0/15     actor/long   10 Gb Full  True
         partner/long
0/16     actor/long   10 Gb Full  True
         partner/long
```

17. Verify that the ISLs are up on the 3132Q-V switch C2: `show port-channel summary`

Ports Eth1/24/1 through Eth1/24/4 should indicate (P), meaning that all four ISL ports are up in the port-channel. Eth1/31 and Eth1/32 should indicate (D) as they are not connected:

```
C2# show port-channel summary
```

```
Flags:  D - Down           P - Up in port-channel (members)
        I - Individual     H - Hot-standby (LACP only)
        s - Suspended      r - Module-removed
        S - Switched       R - Routed
        U - Up (port-channel)
        M - Not in use. Min-links not met
```

```
-----
-----
Group Port-      Type      Protocol  Member Ports
Channel
-----
-----
1      Po1(SU)     Eth       LACP      Eth1/31(D)  Eth1/32(D)
2      Po2(SU)     Eth       LACP      Eth1/24/1(P) Eth1/24/2(P)
Eth1/24/3(P)
                                     Eth1/24/4(P)
```

18. Bring up all of the cluster interconnect ports that are connected to the 3132Q-V switch C2 on all of the nodes: `network port modify`

The following example shows how to bring up the cluster interconnect ports connected to the 3132Q-V switch C2:

```
cluster::*> network port modify -node n1 -port e0b -up-admin true
cluster::*> network port modify -node n1 -port e0c -up-admin true
cluster::*> network port modify -node n2 -port e0b -up-admin true
cluster::*> network port modify -node n2 -port e0c -up-admin true
```

19. Revert all of the migrated cluster interconnect LIFs that are connected to C2 on all of the nodes: `network interface revert`

```
cluster::*> network interface revert -vserver cluster -lif n1_clus2
cluster::*> network interface revert -vserver cluster -lif n1_clus3
cluster::*> network interface revert -vserver cluster -lif n2_clus2
cluster::*> network interface revert -vserver cluster -lif n2_clus3
```

20. Verify that all of the cluster interconnect ports are reverted to their home ports: `network interface`

show

The following example shows that the LIFs on clus2 are reverted to their home ports, and shows that the LIFs are successfully reverted if the ports in the "Current Port" column have a status of `true` in the "Is Home" column. If the Is Home value is `false`, then the LIF is not reverted.

```
cluster::*> network interface show -role cluster
(network interface show)
```

Vserver	Logical Interface	Status Admin/Oper	Network Address/Mask	Current Node	Current Port	Is Home
Cluster						
	n1_clus1	up/up	10.10.0.1/24	n1	e0a	true
	n1_clus2	up/up	10.10.0.2/24	n1	e0b	true
	n1_clus3	up/up	10.10.0.3/24	n1	e0c	true
	n1_clus4	up/up	10.10.0.4/24	n1	e0d	true
	n2_clus1	up/up	10.10.0.5/24	n2	e0a	true
	n2_clus2	up/up	10.10.0.6/24	n2	e0b	true
	n2_clus3	up/up	10.10.0.7/24	n2	e0c	true
	n2_clus4	up/up	10.10.0.8/24	n2	e0d	true

8 entries were displayed.

21. Verify that all of the cluster ports are connected: `network port show`

The following example shows the result of the previous `network port modify` command, verifying that all of the cluster interconnects are `up`:

```
cluster::*> network port show -role cluster
(network port show)
```

```
Node: n1
```

Port	IPspace	Broadcast Domain	Link	MTU	Speed (Mbps) Admin/Open	Health Status	Ignore Health
e0a	cluster	cluster	up	9000	auto/10000	-	-
e0b	cluster	cluster	up	9000	auto/10000	-	-
e0c	cluster	cluster	up	9000	auto/10000	-	-
e0d	cluster	cluster	up	9000	auto/10000	-	-

```
Node: n2
```

Port	IPspace	Broadcast Domain	Link	MTU	Speed (Mbps) Admin/Open	Health Status	Ignore Health
e0a	cluster	cluster	up	9000	auto/10000	-	-
e0b	cluster	cluster	up	9000	auto/10000	-	-
e0c	cluster	cluster	up	9000	auto/10000	-	-
e0d	cluster	cluster	up	9000	auto/10000	-	-

```
8 entries were displayed.
```

22. Ping the remote cluster interfaces and then perform a remote procedure call server check: `cluster ping-cluster`

The following example shows how to ping the remote cluster interfaces:

```

cluster::*> cluster ping-cluster -node n1
Host is n1
Getting addresses from network interface table...
Cluster n1_clus1 n1      e0a    10.10.0.1
Cluster n1_clus2 n1      e0b    10.10.0.2
Cluster n1_clus3 n1      e0c    10.10.0.3
Cluster n1_clus4 n1      e0d    10.10.0.4
Cluster n2_clus1 n2      e0a    10.10.0.5
Cluster n2_clus2 n2      e0b    10.10.0.6
Cluster n2_clus3 n2      e0c    10.10.0.7
Cluster n2_clus4 n2      e0d    10.10.0.8

Local = 10.10.0.1 10.10.0.2 10.10.0.3 10.10.0.4
Remote = 10.10.0.5 10.10.0.6 10.10.0.7 10.10.0.8
Cluster Vserver Id = 4294967293
Ping status:
....
Basic connectivity succeeds on 16 path(s)
Basic connectivity fails on 0 path(s)
.....
Detected 1500 byte MTU on 16 path(s):
  Local 10.10.0.1 to Remote 10.10.0.5
  Local 10.10.0.1 to Remote 10.10.0.6
  Local 10.10.0.1 to Remote 10.10.0.7
  Local 10.10.0.1 to Remote 10.10.0.8
  Local 10.10.0.2 to Remote 10.10.0.5
  Local 10.10.0.2 to Remote 10.10.0.6
  Local 10.10.0.2 to Remote 10.10.0.7
  Local 10.10.0.2 to Remote 10.10.0.8
  Local 10.10.0.3 to Remote 10.10.0.5
  Local 10.10.0.3 to Remote 10.10.0.6
  Local 10.10.0.3 to Remote 10.10.0.7
  Local 10.10.0.3 to Remote 10.10.0.8
  Local 10.10.0.4 to Remote 10.10.0.5
  Local 10.10.0.4 to Remote 10.10.0.6
  Local 10.10.0.4 to Remote 10.10.0.7
  Local 10.10.0.4 to Remote 10.10.0.8

Larger than PMTU communication succeeds on 16 path(s)
RPC status:
4 paths up, 0 paths down (tcp check)
4 paths up, 0 paths down (udp check)

```

23. On each node in the cluster, migrate the interfaces that are associated with the first CN1610 switch CL1, to be replaced: network interface migrate

The following example shows the ports or LIFs being migrated on nodes n1 and n2:

```
cluster::*> network interface migrate -vserver cluster -lif n1_clus1
-source-node n1
-destination-node n1 -destination-port e0b
cluster::*> network interface migrate -vserver cluster -lif n1_clus4
-source-node n1
-destination-node n1 -destination-port e0c
cluster::*> network interface migrate -vserver cluster -lif n2_clus1
-source-node n2
-destination-node n2 -destination-port e0b
cluster::*> network interface migrate -vserver cluster -lif n2_clus4
-source-node n2
-destination-node n2 -destination-port e0c
```

24. Verify the cluster status: `network interface show`

The following example shows that the required cluster LIFs have been migrated to the appropriate cluster ports hosted on cluster switch C2:

```
cluster::*> network interface show -role cluster
(network interface show)
```

Vserver	Logical Interface	Status Admin/Oper	Network Address/Mask	Current Node	Current Port	Is Home
Cluster	n1_clus1	up/up	10.10.0.1/24	n1	e0b	false
	n1_clus2	up/up	10.10.0.2/24	n1	e0b	true
	n1_clus3	up/up	10.10.0.3/24	n1	e0c	true
	n1_clus4	up/up	10.10.0.4/24	n1	e0c	false
	n2_clus1	up/up	10.10.0.5/24	n2	e0b	false
	n2_clus2	up/up	10.10.0.6/24	n2	e0b	true
	n2_clus3	up/up	10.10.0.7/24	n2	e0c	true
	n2_clus4	up/up	10.10.0.8/24	n2	e0c	false

8 entries were displayed.

25. Shut down the node ports that are connected to CL1 on all of the nodes: `network port modify`

The following example shows how to shut down the specified ports on nodes n1 and n2:

```
cluster::*> network port modify -node n1 -port e0a -up-admin false
cluster::*> network port modify -node n1 -port e0d -up-admin false
cluster::*> network port modify -node n2 -port e0a -up-admin false
cluster::*> network port modify -node n2 -port e0d -up-admin false
```

26. Shut down the ISL ports 24, 31, and 32 on the active 3132Q-V switch C2: shutdown

The following example shows how to shut down ISLs 24, 31, and 32 on the active 3132Q-V switch C2:

```
C2# configure
C2(config)# interface ethernet 1/24/1-4
C2(config-if-range)# shutdown
C2(config-if-range)# exit
C2(config)# interface ethernet 1/31-32
C2(config-if-range)# shutdown
C2(config-if-range)# exit
C2(config)# exit
C2#
```

27. Remove the cables that are attached to the CN1610 switch CL1 on all of the nodes.

With supported cabling, you must reconnect the disconnected ports on all of the nodes to the Nexus 3132Q-V switch C1.

28. Remove the QSFP cables from Nexus 3132Q-V C2 port e1/24.

You must connect ports e1/31 and e1/32 on C1 to ports e1/31 and e1/32 on C2 using supported Cisco QSFP optical fiber or direct-attach cables.

29. Restore the configuration on port 24 and remove the temporary port-channel 2 on C2:

The following example copies the `running-configuration` file to the `startup-configuration` file:

```

C2# configure
C2(config)# no interface breakout module 1 port 24 map 10g-4x
C2(config)# no interface port-channel 2
C2(config-if)# interface e1/24
C2(config-if)# description 40GbE Node Port
C2(config-if)# spanning-tree port type edge
C2(config-if)# spanning-tree bpduguard enable
C2(config-if)# mtu 9216
C2(config-if-range)# exit
C2(config)# exit
C2# copy running-config startup-config
[#####] 100%
Copy Complete.

```

30. Bring up ISL ports 31 and 32 on C2, the active 3132Q-V switch: `no shutdown`

The following example shows how to bring up ISLs 31 and 32 on the 3132Q-V switch C2:

```

C2# configure
C2(config)# interface ethernet 1/31-32
C2(config-if-range)# no shutdown
C2(config-if-range)# exit
C2(config)# exit
C2# copy running-config startup-config
[#####] 100%
Copy Complete.

```

31. Verify that the ISL connections are up on the 3132Q-V switch C2: `show port-channel summary`

Ports Eth1/31 and Eth1/32 should indicate (P), meaning that both the ISL ports are up in the port-channel.

```

C1# show port-channel summary
Flags:  D - Down          P - Up in port-channel (members)
        I - Individual    H - Hot-standby (LACP only)
        s - Suspended     r - Module-removed
        S - Switched      R - Routed
        U - Up (port-channel)
        M - Not in use. Min-links not met
-----
-----
Group Port-          Type      Protocol  Member Ports
  Channel
-----
-----
1      Po1 (SU)      Eth       LACP      Eth1/31 (P)  Eth1/32 (P)

```

32. Bring up all of the cluster interconnect ports connected to the new 3132Q-V switch C1 on all of the nodes:
`network port modify`

The following example shows how to bring up all of the cluster interconnect ports connected to the new 3132Q-V switch C1:

```

cluster::*> network port modify -node n1 -port e0a -up-admin true
cluster::*> network port modify -node n1 -port e0d -up-admin true
cluster::*> network port modify -node n2 -port e0a -up-admin true
cluster::*> network port modify -node n2 -port e0d -up-admin true

```

33. Verify the status of the cluster node port: `network port show`

The following example verifies that all of the cluster interconnect ports on n1 and n2 on the new 3132Q-V switch C1 are up:

```

cluster::*> network port show -role cluster
      (network port show)

Node: n1
      Broadcast
Port  IPspace  Domain  Link  MTU  Speed (Mbps)  Health  Ignore
Status Admin/Open  Status  Health
-----
e0a   cluster  cluster  up    9000  auto/10000    -      -
e0b   cluster  cluster  up    9000  auto/10000    -      -
e0c   cluster  cluster  up    9000  auto/10000    -      -
e0d   cluster  cluster  up    9000  auto/10000    -      -

Node: n2
      Broadcast
Port  IPspace  Domain  Link  MTU  Speed (Mbps)  Health  Ignore
Status Admin/Open  Status  Health
-----
e0a   cluster  cluster  up    9000  auto/10000    -      -
e0b   cluster  cluster  up    9000  auto/10000    -      -
e0c   cluster  cluster  up    9000  auto/10000    -      -
e0d   cluster  cluster  up    9000  auto/10000    -      -

8 entries were displayed.

```

34. Revert all of the migrated cluster interconnect LIFs that were originally connected to C1 on all of the nodes:
network interface revert

The following example shows how to revert the migrated cluster LIFs to their home ports:

```

cluster::*> network interface revert -vserver cluster -lif n1_clus1
cluster::*> network interface revert -vserver cluster -lif n1_clus4
cluster::*> network interface revert -vserver cluster -lif n2_clus1
cluster::*> network interface revert -vserver cluster -lif n2_clus4

```

35. Verify that the interface is now home: network interface show

The following example shows the status of cluster interconnect interfaces is up and Is home for n1 and n2:

```
cluster::*> network interface show -role cluster
(network interface show)
```

Vserver	Logical Interface	Status Admin/Oper	Network Address/Mask	Current Node	Current Port	Is Home
Cluster						
	n1_clus1	up/up	10.10.0.1/24	n1	e0a	true
	n1_clus2	up/up	10.10.0.2/24	n1	e0b	true
	n1_clus3	up/up	10.10.0.3/24	n1	e0c	true
	n1_clus4	up/up	10.10.0.4/24	n1	e0d	true
	n2_clus1	up/up	10.10.0.5/24	n2	e0a	true
	n2_clus2	up/up	10.10.0.6/24	n2	e0b	true
	n2_clus3	up/up	10.10.0.7/24	n2	e0c	true
	n2_clus4	up/up	10.10.0.8/24	n2	e0d	true

```
8 entries were displayed.
```

36. Ping the remote cluster interfaces and then perform a remote procedure call server check: `cluster ping-cluster`

The following example shows how to ping the remote cluster interfaces:

```

cluster::*> cluster ping-cluster -node n1
Host is n1
Getting addresses from network interface table...
Cluster n1_clus1 n1      e0a    10.10.0.1
Cluster n1_clus2 n1      e0b    10.10.0.2
Cluster n1_clus3 n1      e0c    10.10.0.3
Cluster n1_clus4 n1      e0d    10.10.0.4
Cluster n2_clus1 n2      e0a    10.10.0.5
Cluster n2_clus2 n2      e0b    10.10.0.6
Cluster n2_clus3 n2      e0c    10.10.0.7
Cluster n2_clus4 n2      e0d    10.10.0.8

Local = 10.10.0.1 10.10.0.2 10.10.0.3 10.10.0.4
Remote = 10.10.0.5 10.10.0.6 10.10.0.7 10.10.0.8
Cluster Vserver Id = 4294967293
Ping status:
....
Basic connectivity succeeds on 16 path(s)
Basic connectivity fails on 0 path(s)
.....
Detected 1500 byte MTU on 16 path(s):
  Local 10.10.0.1 to Remote 10.10.0.5
  Local 10.10.0.1 to Remote 10.10.0.6
  Local 10.10.0.1 to Remote 10.10.0.7
  Local 10.10.0.1 to Remote 10.10.0.8
  Local 10.10.0.2 to Remote 10.10.0.5
  Local 10.10.0.2 to Remote 10.10.0.6
  Local 10.10.0.2 to Remote 10.10.0.7
  Local 10.10.0.2 to Remote 10.10.0.8
  Local 10.10.0.3 to Remote 10.10.0.5
  Local 10.10.0.3 to Remote 10.10.0.6
  Local 10.10.0.3 to Remote 10.10.0.7
  Local 10.10.0.3 to Remote 10.10.0.8
  Local 10.10.0.4 to Remote 10.10.0.5
  Local 10.10.0.4 to Remote 10.10.0.6
  Local 10.10.0.4 to Remote 10.10.0.7
  Local 10.10.0.4 to Remote 10.10.0.8

Larger than PMTU communication succeeds on 16 path(s)
RPC status:
4 paths up, 0 paths down (tcp check)
4 paths up, 0 paths down (udp check)

```

37. Expand the cluster by adding nodes to the Nexus 3132Q-V cluster switches.
38. Display the information about the devices in your configuration:

- network device-discovery show
- network port show -role cluster
- network interface show -role cluster
- system cluster-switch show

The following examples show nodes n3 and n4 with 40 GbE cluster ports connected to ports e1/7 and e1/8, respectively on both the Nexus 3132Q-V cluster switches, and both nodes have joined the cluster. The 40 GbE cluster interconnect ports used are e4a and e4e.

```

cluster::*> network device-discovery show

      Local  Discovered
Node  Port    Device      Interface      Platform
-----
n1    /cdp
      e0a    C1          Ethernet1/1/1  N3K-C3132Q-V
      e0b    C2          Ethernet1/1/1  N3K-C3132Q-V
      e0c    C2          Ethernet1/1/2  N3K-C3132Q-V
      e0d    C1          Ethernet1/1/2  N3K-C3132Q-V
n2    /cdp
      e0a    C1          Ethernet1/1/3  N3K-C3132Q-V
      e0b    C2          Ethernet1/1/3  N3K-C3132Q-V
      e0c    C2          Ethernet1/1/4  N3K-C3132Q-V
      e0d    C1          Ethernet1/1/4  N3K-C3132Q-V
n3    /cdp
      e4a    C1          Ethernet1/7     N3K-C3132Q-V
      e4e    C2          Ethernet1/7     N3K-C3132Q-V
n4    /cdp
      e4a    C1          Ethernet1/8     N3K-C3132Q-V
      e4e    C2          Ethernet1/8     N3K-C3132Q-V

12 entries were displayed.

```

```
cluster::*> network port show -role cluster
(network port show)
```

```
Node: n1
```

Port	IPspace	Broadcast Domain	Link	MTU	Speed (Mbps) Admin/Open	Health Status	Ignore Health
e0a	cluster	cluster	up	9000	auto/10000	-	-
e0b	cluster	cluster	up	9000	auto/10000	-	-
e0c	cluster	cluster	up	9000	auto/10000	-	-
e0d	cluster	cluster	up	9000	auto/10000	-	-

```
Node: n2
```

Port	IPspace	Broadcast Domain	Link	MTU	Speed (Mbps) Admin/Open	Health Status	Ignore Health
e0a	cluster	cluster	up	9000	auto/10000	-	-
e0b	cluster	cluster	up	9000	auto/10000	-	-
e0c	cluster	cluster	up	9000	auto/10000	-	-
e0d	cluster	cluster	up	9000	auto/10000	-	-

```
Node: n3
```

Port	IPspace	Broadcast Domain	Link	MTU	Speed (Mbps) Admin/Open	Health Status	Ignore Health
e4a	cluster	cluster	up	9000	auto/40000	-	-
e4e	cluster	cluster	up	9000	auto/40000	-	-

```
Node: n4
```

Port	IPspace	Broadcast Domain	Link	MTU	Speed (Mbps) Admin/Open	Health Status	Ignore Health
e4a	cluster	cluster	up	9000	auto/40000	-	-
e4e	cluster	cluster	up	9000	auto/40000	-	-

```
12 entries were displayed.
```

```
cluster::*> network interface show -role cluster
(network interface show)
```

Vserver	Logical Interface	Status Admin/Oper	Network Address/Mask	Current Node	Current Port	Is Home

Cluster						
	n1_clus1	up/up	10.10.0.1/24	n1	e0a	true
	n1_clus2	up/up	10.10.0.2/24	n1	e0b	true
	n1_clus3	up/up	10.10.0.3/24	n1	e0c	true
	n1_clus4	up/up	10.10.0.4/24	n1	e0d	true
	n2_clus1	up/up	10.10.0.5/24	n2	e0a	true
	n2_clus2	up/up	10.10.0.6/24	n2	e0b	true
	n2_clus3	up/up	10.10.0.7/24	n2	e0c	true
	n2_clus4	up/up	10.10.0.8/24	n2	e0d	true
	n3_clus1	up/up	10.10.0.9/24	n3	e4a	true
	n3_clus2	up/up	10.10.0.10/24	n3	e4e	true
	n4_clus1	up/up	10.10.0.11/24	n4	e4a	true
	n4_clus2	up/up	10.10.0.12/24	n4	e4e	true

```
12 entries were displayed.
```



```
cluster::> system cluster-switch show
```

Switch	Type	Address	Model
C1	cluster-network	10.10.1.103	NX3132V
Serial Number: FOX000001			
Is Monitored: true			
Reason:			
Software Version: Cisco Nexus Operating System (NX-OS) Software,			
Version			
7.0(3)I4(1)			
Version Source: CDP			
C2	cluster-network	10.10.1.104	NX3132V
Serial Number: FOX000002			
Is Monitored: true			
Reason:			
Software Version: Cisco Nexus Operating System (NX-OS) Software,			
Version			
7.0(3)I4(1)			
Version Source: CDP			
CL1	cluster-network	10.10.1.101	CN1610
Serial Number: 01234567			
Is Monitored: true			
Reason:			
Software Version: 1.2.0.7			
Version Source: ISDP			
CL2	cluster-network	10.10.1.102	CN1610
Serial Number: 01234568			
Is Monitored: true			
Reason:			
Software Version: 1.2.0.7			
Version Source: ISDP			

4 entries were displayed.

39. Remove the replaced CN1610 switches if they are not automatically removed: `system cluster-switch delete`

The following example shows how to remove the CN1610 switches:

```
cluster::> system cluster-switch delete -device CL1
cluster::> system cluster-switch delete -device CL2
```

40. Configure clusters clus1 and clus4 to `-auto-revert` on each node and confirm:

```
cluster::*> network interface modify -vserver node1 -lif clus1 -auto
-revert true
cluster::*> network interface modify -vserver node1 -lif clus4 -auto
-revert true
cluster::*> network interface modify -vserver node2 -lif clus1 -auto
-revert true
cluster::*> network interface modify -vserver node2 -lif clus4 -auto
-revert true
```

41. Verify that the proper cluster switches are monitored: `system cluster-switch show`

```
cluster::> system cluster-switch show
```

Switch	Type	Address	Model
C1	cluster-network	10.10.1.103	NX3132V
Serial Number: FOX000001			
Is Monitored: true			
Reason:			
Software Version: Cisco Nexus Operating System (NX-OS) Software,			
Version			
7.0(3)I4(1)			
Version Source: CDP			
C2	cluster-network	10.10.1.104	NX3132V
Serial Number: FOX000002			
Is Monitored: true			
Reason:			
Software Version: Cisco Nexus Operating System (NX-OS) Software,			
Version			
7.0(3)I4(1)			
Version Source: CDP			

2 entries were displayed.

42. Enable the cluster switch health monitor log collection feature for collecting switch-related log files:

```
system cluster-switch log setup-password
```

```
system cluster-switch log enable-collection
```

```
cluster::*> system cluster-switch log setup-password
Enter the switch name: <return>
The switch name entered is not recognized.
Choose from the following list:
C1
C2

cluster::*> system cluster-switch log setup-password

Enter the switch name: C1
RSA key fingerprint is e5:8b:c6:dc:e2:18:18:09:36:63:d9:63:dd:03:d9:cc
Do you want to continue? {y|n}::[n] y

Enter the password: <enter switch password>
Enter the password again: <enter switch password>

cluster::*> system cluster-switch log setup-password

Enter the switch name: C2
RSA key fingerprint is 57:49:86:a1:b9:80:6a:61:9a:86:8e:3c:e3:b7:1f:b1
Do you want to continue? {y|n}:: [n] y

Enter the password: <enter switch password>
Enter the password again: <enter switch password>

cluster::*> system cluster-switch log enable-collection

Do you want to enable cluster log collection for all nodes in the
cluster?
{y|n}: [n] y

Enabling cluster switch log collection.

cluster::*>
```



If any of these commands return an error, contact NetApp support.

43. If you suppressed automatic case creation, reenable it by invoking an AutoSupport message: `system node autosupport invoke -node * -type all -message MAINT=END`

Related information

[NetApp CN1601 and CN1610 description page](#)

[Cisco Ethernet Switch description page](#)

[Hardware Universe](#)

Copyright Information

Copyright © 2022 NetApp, Inc. All rights reserved. Printed in the U.S. No part of this document covered by copyright may be reproduced in any form or by any means-graphic, electronic, or mechanical, including photocopying, recording, taping, or storage in an electronic retrieval system- without prior written permission of the copyright owner.

Software derived from copyrighted NetApp material is subject to the following license and disclaimer:

THIS SOFTWARE IS PROVIDED BY NETAPP "AS IS" AND WITHOUT ANY EXPRESS OR IMPLIED WARRANTIES, INCLUDING, BUT NOT LIMITED TO, THE IMPLIED WARRANTIES OF MERCHANTABILITY AND FITNESS FOR A PARTICULAR PURPOSE, WHICH ARE HEREBY DISCLAIMED. IN NO EVENT SHALL NETAPP BE LIABLE FOR ANY DIRECT, INDIRECT, INCIDENTAL, SPECIAL, EXEMPLARY, OR CONSEQUENTIAL DAMAGES (INCLUDING, BUT NOT LIMITED TO, PROCUREMENT OF SUBSTITUTE GOODS OR SERVICES; LOSS OF USE, DATA, OR PROFITS; OR BUSINESS INTERRUPTION) HOWEVER CAUSED AND ON ANY THEORY OF LIABILITY, WHETHER IN CONTRACT, STRICT LIABILITY, OR TORT (INCLUDING NEGLIGENCE OR OTHERWISE) ARISING IN ANY WAY OUT OF THE USE OF THIS SOFTWARE, EVEN IF ADVISED OF THE POSSIBILITY OF SUCH DAMAGE.

NetApp reserves the right to change any products described herein at any time, and without notice. NetApp assumes no responsibility or liability arising from the use of products described herein, except as expressly agreed to in writing by NetApp. The use or purchase of this product does not convey a license under any patent rights, trademark rights, or any other intellectual property rights of NetApp.

The product described in this manual may be protected by one or more U.S. patents, foreign patents, or pending applications.

RESTRICTED RIGHTS LEGEND: Use, duplication, or disclosure by the government is subject to restrictions as set forth in subparagraph (c)(1)(ii) of the Rights in Technical Data and Computer Software clause at DFARS 252.277-7103 (October 1988) and FAR 52-227-19 (June 1987).

Trademark Information

NETAPP, the NETAPP logo, and the marks listed at <http://www.netapp.com/TM> are trademarks of NetApp, Inc. Other company and product names may be trademarks of their respective owners.