



# Controller

## Install and maintain

NetApp  
December 18, 2024

# Table of Contents

- Controller ..... 1
  - Controller replacement workflow - AFF A20, AFF A30, and AFF A50 ..... 1
  - Requirements and considerations - AFF A20, AFF A30, and AFF A50 ..... 1
  - Shut down the impaired controller - AFF A20, AFF A30, and AFF A50 ..... 2
  - Replace the controller - AFF A20, AFF A30, and AFF A50 ..... 3
  - Restore and verify the system configuration - AFF A20, AFF A30, and AFF A50 ..... 14
  - Give back the controller - AFF A20, AFF A30, and AFF A50 ..... 15
  - Complete controller replacement - AFF A20, AFF A30, and AFF A50 ..... 19

# Controller

## Controller replacement workflow - AFF A20, AFF A30, and AFF A50

Follow these workflow steps to replace your controller.

1

### Review the controller replacement requirements

To replace the controller, you must meet certain requirements.

2

### Shut down the impaired controller

Shut down or take over the impaired controller so that the healthy controller continues to serve data from the impaired controller storage.

3

### Replace the controller

Replacing the controller includes removing the impaired controller, moving FRU components to the replacement controller, installing the replacement controller in the chassis, setting the time and date, and then recabling.

4

### Restore and verify the system configuration

Verify the low-level system configuration of the replacement controller and reconfigure system settings as necessary.

5

### Give back the controller

Transfer the ownership of storage resources back to the replacement controller.

6

### Complete controller replacement

Verify the LIFs, check cluster health, and return the failed part to NetApp.

## Requirements and considerations - AFF A20, AFF A30, and AFF A50

You must review the requirements and considerations for the controller replacement procedure.

### Requirements

- All shelves must be working properly.

- The healthy controller must be able to take over the controller that is being replaced (referred to in this procedure as the “impaired controller”).
- You must replace a controller with a controller of the same model type. You cannot upgrade your system by just replacing the controller.
- You cannot change any drives or shelves as part of this procedure.
- You must always capture the controller’s console output to a text log file.

The console output provides you with a record of the procedure you can use to troubleshoot issues you might encounter during the replacement process.

## Considerations

- It is important that you apply the commands in this procedure to the correct controller:
  - The *impaired* controller is the controller that is being replaced.
  - The *replacement* controller is the new controller that is replacing the impaired controller.
  - The *healthy* controller is the surviving controller.
- If needed, you can turn on the storage system location (blue) LEDs to aid in physically locating the affected storage system. Log into the BMC using SSH and enter the `system location-led on` command.

A storage system has three location LEDs: one on the operator display panel and one on each controller. Location LEDs remain illuminated for 30 minutes.

You can turn them off by entering the `system location-led off` command. If you are unsure if the LEDs are on or off, you can check their state by entering the `system location-led show` command.

## Shut down the impaired controller - AFF A20, AFF A30, and AFF A50

Shut down or take over the impaired controller.

To shut down the impaired controller, you must determine the status of the controller and, if necessary, take over the controller so that the healthy controller continues to serve data from the impaired controller storage.

### About this task

- If you have a SAN system, you must have checked event messages (`cluster kernel-service show`) for the impaired controller SCSI blade. The `cluster kernel-service show` command (from `priv advanced mode`) displays the node name, [quorum status](#) of that node, availability status of that node, and operational status of that node.

Each SCSI-blade process should be in quorum with the other nodes in the cluster. Any issues must be resolved before you proceed with the replacement.

- If you have a cluster with more than two nodes, it must be in quorum. If the cluster is not in quorum or a healthy controller shows false for eligibility and health, you must correct the issue before shutting down the impaired controller; see [Synchronize a node with the cluster](#).

### Steps

1. If AutoSupport is enabled, suppress automatic case creation by invoking an AutoSupport message:

```
system node autosupport invoke -node * -type all -message MAINT=<# of hours>h
```

The following AutoSupport message suppresses automatic case creation for two hours: `cluster1:>`

```
system node autosupport invoke -node * -type all -message MAINT=2h
```

2. Disable automatic giveback from the console of the healthy controller: `storage failover modify -node local -auto-giveback false`



When you see *Do you want to disable auto-giveback?*, enter *y*.

3. Take the impaired controller to the LOADER prompt:

| If the impaired controller is displaying... | Then...  |
|---|--|
| The LOADER prompt                           | Go to the next step.   |
| Waiting for giveback...                     | Press Ctrl-C, and then respond <i>y</i> when prompted.   |
| System prompt or password prompt            | Take over or halt the impaired controller from the healthy controller:<br><code>storage failover takeover -ofnode<br/>impaired_node_name</code><br><br>When the impaired controller shows Waiting for giveback..., press Ctrl-C, and then respond <i>y</i> . |

## Replace the controller - AFF A20, AFF A30, and AFF A50

To replace the controller, you must remove the impaired controller, move FRU components from the impaired controller to the replacement controller, install the replacement controller in the chassis, set the time and date, and then recable the replacement controller.

### Step 1: Remove the controller

You must remove the controller from the chassis when you replace the controller or replace a component inside the controller.

#### Before you begin

All other components in the storage system must be functioning properly; if not, you must contact [NetApp Support](#) before continuing with this procedure.

#### Steps

1. On the impaired controller, make sure the NV LED is off.

When the NV LED is off, destaging is complete and it is safe to remove the impaired controller.



If the NV LED is flashing (green), destage is in progress. You must wait for the NV LED to turn off. However, if the flashing continues for longer than five minutes, contact [NetApp Support](#) before continuing with this procedure.

The NV LED is located next to the NV icon on the controller.

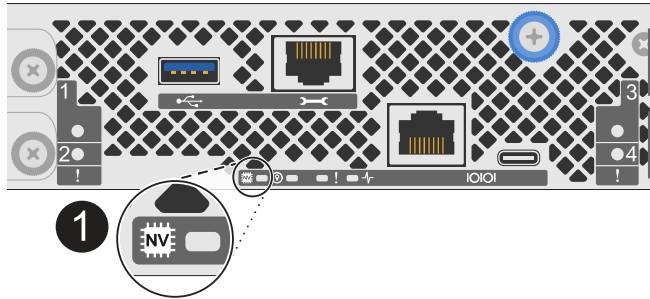

|          |                                   |
|----------|-----------------------------------|
| <b>1</b> | NV icon and LED on the controller |
|----------|-----------------------------------|

- If you are not already grounded, properly ground yourself.
- Disconnect the power on the impaired controller:



Power supplies (PSUs) do not have a power switch.

| If you are disconnecting a... | Then...  |
|-------------------------------|--|
| AC PSU                        | <ol style="list-style-type: none"> <li>Open the power cord retainer.</li> <li>Unplug the power cord from the PSU and set it aside.</li> </ol>                                      |
| DC PSU                        | <ol style="list-style-type: none"> <li>Unscrew the two thumb screws on the D-SUB DC power cord connector.</li> <li>Unplug the power cord from the PSU and set it aside.</li> </ol> |

- Unplug all cables from the impaired controller.

Keep track of where the cables were connected.

- Remove the impaired controller:

The following illustration shows the operation of the controller handles (from the left side of the controller) when removing a controller:

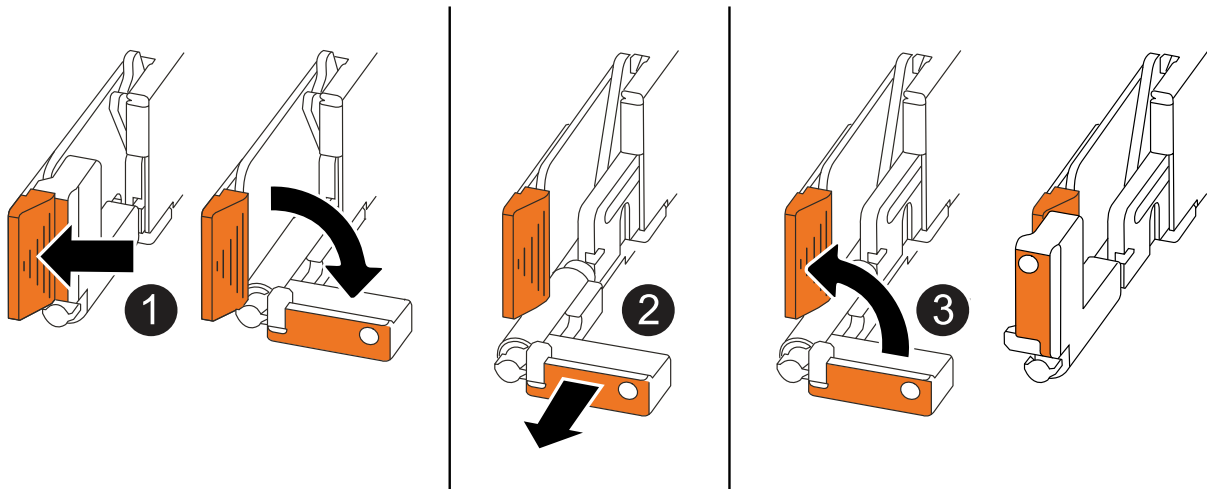

|                 |   |
|-----------------|---|
| <p><b>1</b></p> | <p>On both ends of the controller, push the vertical locking tabs outward to release the handles.</p>   |
| <p><b>2</b></p> | <ul style="list-style-type: none"> <li>• Pull the handles towards you to unseat the controller from the midplane.</li> </ul> <p>As you pull, the handles extend out from the controller and then you feel some resistance, keep pulling.</p> <ul style="list-style-type: none"> <li>• Slide the controller out of the chassis while supporting the bottom of the controller, and place it on a flat, stable surface.</li> </ul> |
| <p><b>3</b></p> | <p>If needed, rotate the handles upright (next to the tabs) to move them out of the way.</p>  |

6. Open the controller cover by turning the thumbscrew counterclockwise to loosen, and then open the cover.

## Step 2: Move the power supply

Move the power supply (PSU) to the replacement controller.

1. Move the PSU from the impaired controller:

Make sure the left side controller handle is in the upright position to allow you access to the PSU.

### Option 1: Move an AC PSU

To move an AC PSU, complete the following steps.

#### Steps

1. Remove the AC PSU from the impaired controller:

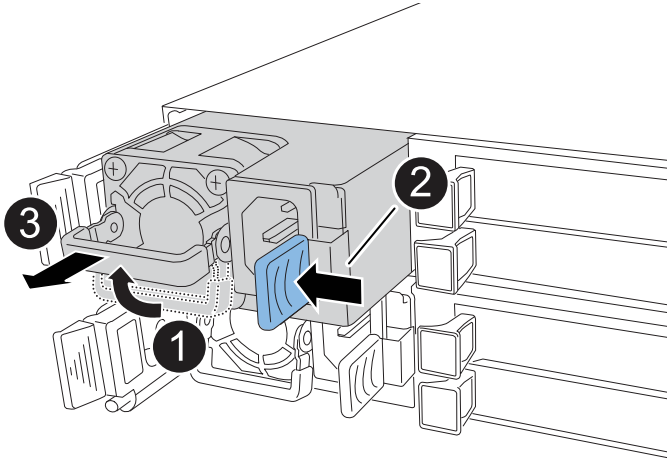

|   |  |
|---|--|
| 1 | Rotate the PSU handle up, to its horizontal position, and then grasp it.   |
| 2 | With your thumb, press the blue tab to release the PSU from the controller.  |
| 3 | Pull the PSU out of the controller while using your other hand to support its weight.<br><br> The PSU is short. Always use two hands to support it when removing it from the controller so that it does not suddenly swing free from the controller and injure you. |

2. Insert the PSU into the replacement controller:

- a. Using both hands, support and align the edges of the PSU with the opening in the controller.
- b. Gently push the PSU into the controller until the locking tab clicks into place.

A PSU will only properly engage with the internal connector and lock in place one way.



To avoid damaging the internal connector, do not use excessive force when sliding the PSU into the controller.

- c. Rotate the handle down, so it is out of the way of normal operations.

### Option 2: Move a DC PSU

To move a DC PSU, complete the following steps.

#### Steps

1. Remove the DC PSU from the impaired controller:



- a. Rotate the handle up, to its horizontal position, and then grasp it.
- b. With your thumb, press the terracotta tab to release the locking mechanism.
- c. Pull the PSU out of the controller while using your other hand to support its weight.



The PSU is short. Always use two hands to support it when removing it from the controller so that it does not swing free from the controller and injure you.

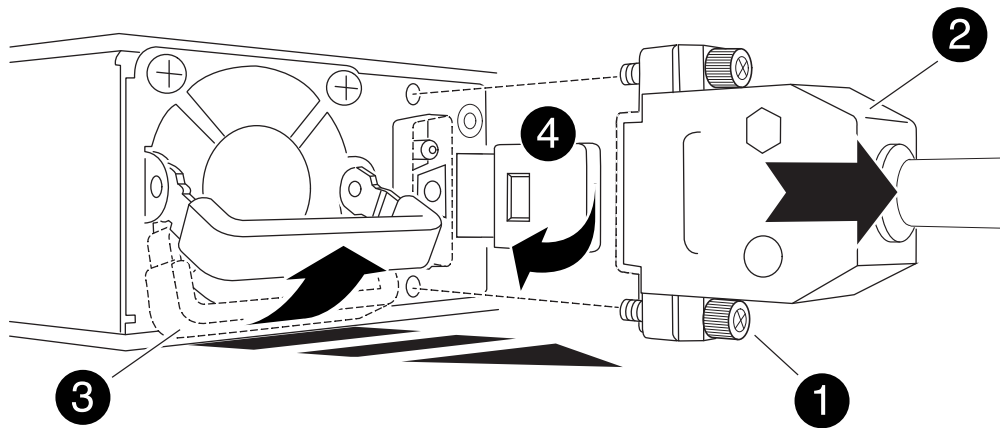

|          |                                   |
|----------|-----------------------------------|
| <b>1</b> | Thumb screws                      |
| <b>2</b> | D-SUB DC power PSU cord connector |
| <b>3</b> | Power supply handle               |
| <b>4</b> | Terracotta PSU locking tab        |

2. Insert the PSU into the replacement controller:
  - a. Using both hands, support and align the edges of the PSU with the opening in the controller.
  - b. Gently slide the PSU into the controller until the locking tab clicks into place.

A PSU must properly engage with the internal connector and locking mechanism. Repeat this step if you feel the PSU is not properly seated.



To avoid damaging the internal connector, do not use excessive force when sliding the PSU into the controller.

- c. Rotate the handle down, so it is out of the way of normal operations.

### Step 3: Move the fans

Move the fans to the replacement controller.

1. Remove one of the fans from the impaired controller:

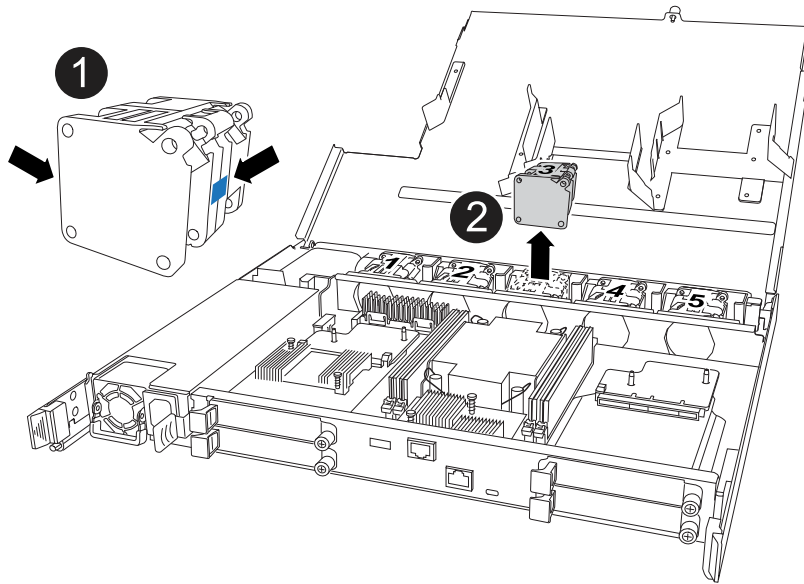

|   |  |
|---|--|
| 1 | Hold both sides of the fan at the blue touch points. |
| 2 | Pull the fan straight up and out its socket.         |

2. Insert the fan into the replacement controller by aligning it within the guides, and then push down until the fan connector is fully seated in the socket.
3. Repeat these steps for the remaining fans.

### Step 4: Move the NV battery

Move the NV battery to the replacement controller.

1. Remove the NV battery from the impaired controller:

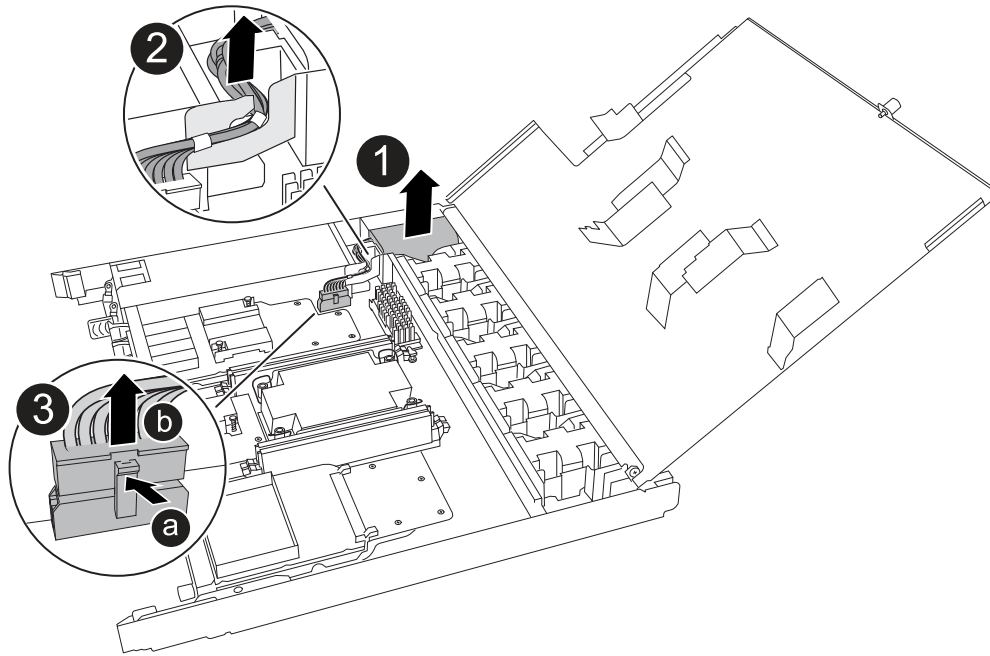

|                 |  |
|-----------------|--|
| <p><b>1</b></p> | <p>Lift the NV battery up and out of its compartment.</p>  |
| <p><b>2</b></p> | <p>Remove the wiring harness from its retainer.</p>  |
| <p><b>3</b></p> | <p>1. Push in and hold the tab on the connector.<br/>2. Pull the connector up and out of the socket.</p> <p>As you pull up, gently rock the connector from end to end (lengthwise) to unseat it.</p> |

2. Install the NV battery into the replacement controller:

- a. Plug the wiring connector into its socket.
- b. Route the wiring along the side of the power supply, into its retainer, and then through the channel in front of the NV battery compartment.
- c. Place the NV battery into the compartment.

The NV battery should sit flush in its compartment.

## Step 5: Move system DIMMs

Move the DIMMs to the replacement controller.

If you have DIMM blanks, you do not need to move them, the replacement controller should come with them installed.

1. Remove one of the DIMMs from the impaired controller:

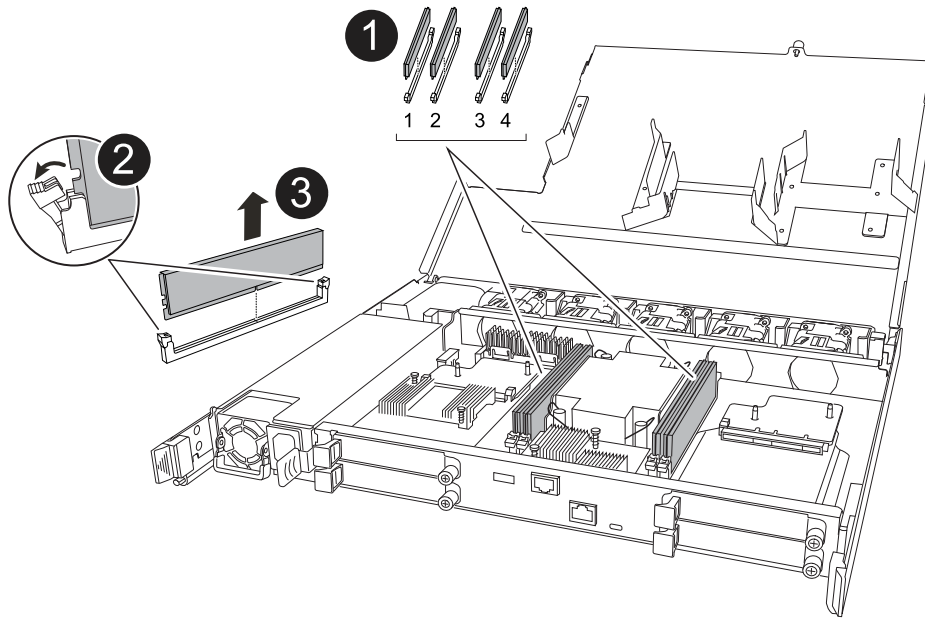

|                 |  |
|-----------------|--|
| <p><b>1</b></p> | <p>DIMM slot numbering and positions.</p> <p><b>i</b> Depending on your storage system model, you will have two or four DIMMs.</p>   |
| <p><b>2</b></p> | <ul style="list-style-type: none"> <li>• Note the orientation of the DIMM in the socket so that you can insert the DIMM in the replacement controller in the proper orientation.</li> <li>• Eject the DIMM by slowly pushing apart the two DIMM ejector tabs on both ends of the DIMM slot.</li> </ul> <p><b>i</b> Carefully hold the DIMM by the corners or edges to avoid pressure on the DIMM circuit board components.</p> |
| <p><b>3</b></p> | <p>Lift the DIMM up and out of the slot.</p> <p>The ejector tabs remain in the open position.</p>  |

2. Install the DIMM in the replacement controller:

- Make sure that the DIMM ejector tabs on the connector are in the open position.
- Hold the DIMM by the corners, and then insert the DIMM squarely into the slot.

The notch on the bottom of the DIMM, among the pins, should line up with the tab in the slot.

When inserted correctly, the DIMM should go in easily but fit tightly in the slot. If not, reinsert the DIMM.

- Visually inspect the DIMM to verify that it is evenly aligned and fully inserted into the slot.
- Push down carefully, but firmly, on the top edge of the DIMM until the ejector tabs snap into place over the notches at both ends of the DIMM.

3. Repeat these steps for the remaining DIMMs.

## Step 6: Move the boot media

Move the boot media to the replacement controller.

1. Remove the boot media from the impaired controller:

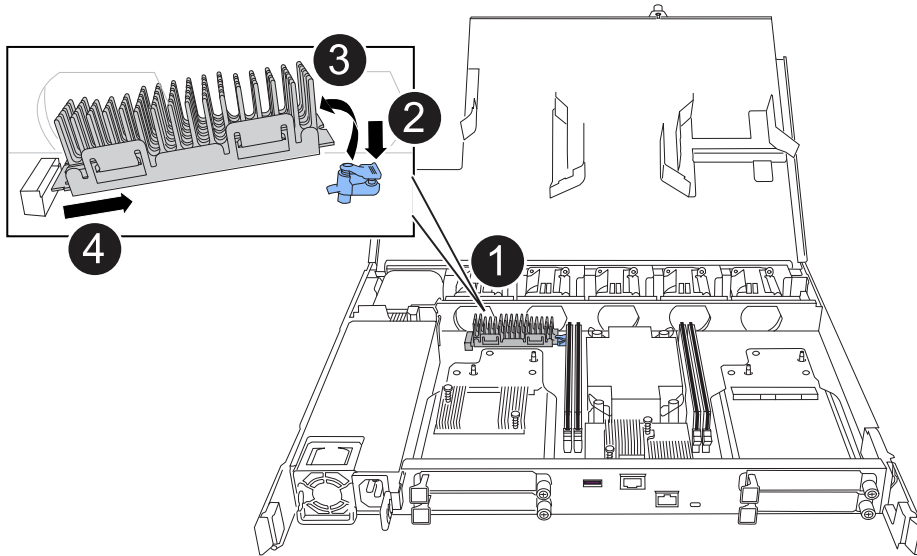

|          |   |
|----------|---|
| <b>1</b> | Boot media location   |
| <b>2</b> | Press down on the blue tab to release the right end of the boot media.  |
| <b>3</b> | Lift the right end of the boot media up at a slight angle to get a good grip along the sides of the boot media. |
| <b>4</b> | Gently pull the left end of the boot media out of its socket.   |

2. Install the boot media into the replacement controller:

- a. Slide the socket end of the boot media into its socket.
- b. At the opposite end of the boot media, press down and hold the blue tab (in the open position), gently push down on that end of the boot media until it stops, and then release the tab to lock the boot media into place.

## Step 7: Move the I/O modules

Move the I/O modules and any I/O blanking modules to the replacement controller.

1. Unplug cabling from one of the I/O modules.

Make sure to label the cables so that you know where they came from.

2. Remove the I/O module from the impaired controller:

Make sure that you keep track of which slot the I/O module was in.

If you are removing the I/O module in slot 4, make sure the right side controller handle is in the upright position to allow you access to the I/O module.

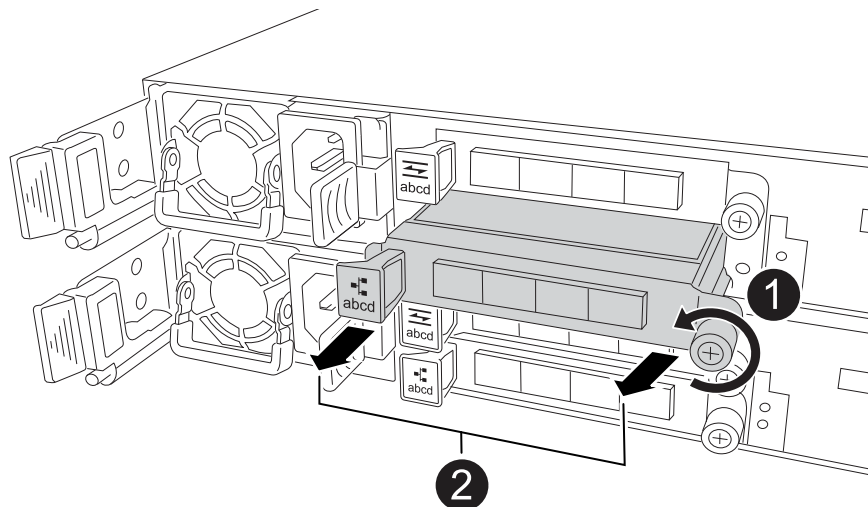

|   |  |
|---|--|
| 1 | Turn the I/O module thumbscrew counterclockwise to loosen.   |
| 2 | Pull the I/O module out of the controller using the port label tab on the left and the thumbscrew. |

3. Install the I/O module into the replacement controller:

- a. Align the I/O module with the edges of the slot.
- b. Gently push the I/O module all the way into the slot, making sure to properly seat the module into the connector.

You can use the tab on the left and the thumbscrew to push in the I/O Module.

- c. Turn the thumbscrew clockwise to tighten.

4. Repeat these steps to move the remaining I/O modules and any I/O blanking modules to the replacement controller.

## Step 8: Install the controller

Reinstall the controller into the chassis and reboot it.

### About this task

The following illustration shows the operation of the controller handles (from the left side of a controller) when reinstalling the controller, and can be used as a reference for the rest of the controller reinstallation steps.

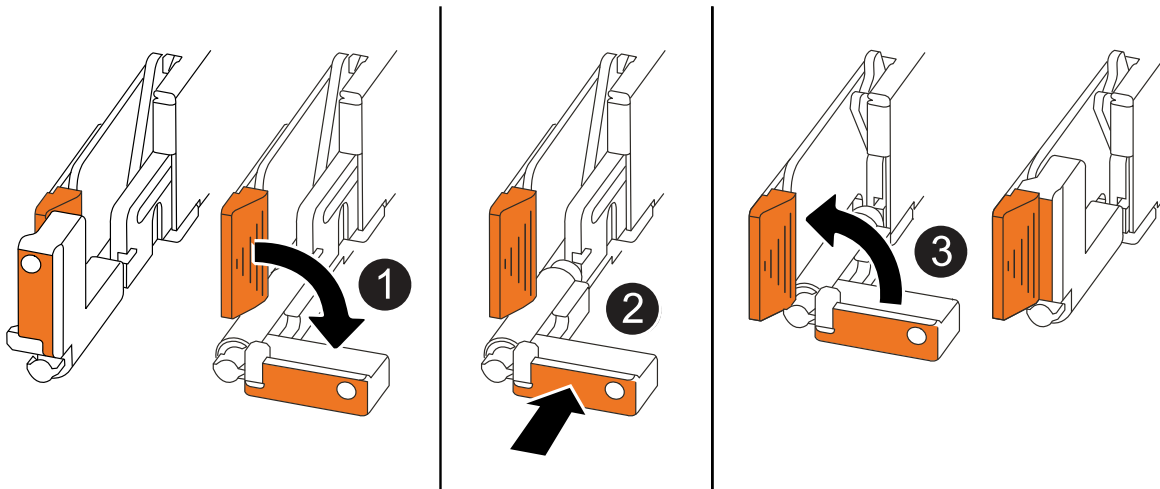

|   |  |
|---|--|
| 1 | If you rotated the controller handles upright (next to the tabs) to move them out of the way while you serviced the controller, rotate them down to the horizontal position. |
| 2 | Push the handles to reinsert the controller into the chassis halfway and then, when instructed, push until the controller is fully seated.                                   |
| 3 | Rotate the handles to the upright position and lock in place with the locking tabs.  |

### Steps

1. Close the controller cover and turn the thumbscrew clockwise until tightened.
2. Insert the controller halfway into the chassis.

Align the rear of the controller with the opening in the chassis, and then gently push the controller using the handles.



Do not completely insert the controller in the chassis until instructed to do so.

3. Connect the console cable to the console port on the controller and to the laptop so that the laptop receives console messages when the controller reboots.
4. Fully seat the controller in the chassis:
  - a. Firmly push on the handles until the controller meets the midplane and is fully seated.



Do not use excessive force when sliding the controller into the chassis; it could damage the connectors.

- b. Rotate the controller handles up and lock in place with the tabs.



The controller begins to boot as soon as it is fully seated in the chassis.

5. Take the controller to the LOADER prompt by pressing CTRL-C to abort AUTOBOOT.
6. Set the time and date on the controller:

Make sure you are at the controller's LOADER prompt.

- a. Display the date and time on the controller:

```
show date
```



Time and date default is in GMT. You have the option to display in local time and in 24hr mode.

- b. Set the current time in GMT:

```
set time hh:mm:ss
```

You can get the current GMT from the healthy node:

```
date -u
```

- c. Set the current date in GMT:

```
set date mm/dd/yyyy
```

You can get the current GMT from the healthy node:

```
date -u
```

7. Recable the controller as needed.
8. Reconnect the power cord to the power supply (PSU).

Once power is restored to the PSU, the status LED should be green.

| If you are reconnecting a... | Then...   |
|------------------------------|---|
| AC PSU                       | <ol style="list-style-type: none"><li>1. Plug the power cord into the PSU.</li><li>2. Secure the power cord with the power cord retainer.</li></ol>   |
| DC PSU                       | <ol style="list-style-type: none"><li>1. Plug the D-SUB DC power cord connector into the PSU.</li><li>2. Tighten the two thumb screws to secure the D-SUB DC power cord connector to the PSU.</li></ol> |

## Restore and verify the system configuration - AFF A20, AFF A30, and AFF A50

Verify the low-level system configuration of the replacement controller and reconfigure the system settings as necessary.

### Step 1: Verify HA config settings

You must verify the HA state of the controller and, if necessary, update the state to match your storage system configuration.

1. Boot to maintenance mode:



```
boot_ontap maint
```

- a. Enter `y` when you see *Continue with boot?*.

If you see the *System ID mismatch* warning message, enter `y`.

2. Enter `sysconfig -v` and capture the display contents.



If you see *PERSONALITY MISMATCH* contact customer support.

3. From the `sysconfig -v` output, compare the adapter card information with the cards and locations in the replacement controller.
4. Verify that all components display the same HA state:

```
ha-config show
```

The HA state should be the same for all components.

5. If the displayed system state of the controller does not match your storage system configuration, set the HA state for the controller:

```
ha-config modify controller ha-state
```

The value for HA-state can be one of the following:

- `ha`
- `non-ha` (not supported)

6. Confirm that the setting has changed:

```
ha-config show
```

## Step 2: Verify disk list

1. Verify that the adapter lists the paths to all disks:

```
storage show disk -p
```

If you see any issues, check cabling and reseal cables.

2. Exit Maintenance mode:

```
halt
```

## Give back the controller - AFF A20, AFF A30, and AFF A50

Give back the controller.

## **Give back the controller**

Reset encryption if enabled and return the controller to normal operation.

## No encryption

1. From the LOADER prompt, enter `boot_ontap`.
2. Press <enter> when console messages stop.
  - If you see the *login* prompt, go to the next step at the end of this section.
  - If you see *Waiting for giveback*, press the <enter> key, log into the partner node, and then go to the next step at the end of this section.
3. Return the impaired controller to normal operation by giving back its storage: `storage failover giveback -ofnode impaired_node_name`
4. If automatic giveback was disabled, reenable it: `storage failover modify -node local -auto-giveback true`
5. If AutoSupport is enabled, restore/unsuppress automatic case creation: `system node autosupport invoke -node * -type all -message MAINT=END`

## Onboard encryption (OKM)

1. From the LOADER prompt, enter `boot_ontap maint`.
2. Boot to the ONTAP menu from the LOADER prompt `boot_ontap menu` and select option 10.
3. Enter the OKM passphrase.



You are prompted twice for the passphrase.

4. Enter the backup key data when prompted.
5. At the boot menu, enter option 1 for normal boot.
6. Press <enter> when *Waiting for giveback* is displayed.
7. Move the console cable to the partner node and login as `admin`.
8. Give back only the CFO aggregates (the root aggregate): `storage failover giveback -fromnode local -only-cfo-aggregates true`
  - If you encounter errors, contact [NetApp Support](#).
9. Wait 5 minutes after the giveback report completes, and check failover status and giveback status: `storage failover show` and `storage failover show-giveback`.
10. Synchronize and verify status of the keys:
  - a. Move the console cable back to the replacement controller.
  - b. Synchronize missing keys: `security key-manager onboard sync`



You are prompted for the cluster-wide passphrase of OKM for the cluster.

- c. Verify status of the keys: `security key-manager key query -restored false`

The output should show no results when when properly synchronized.

If the output shows results (the key IDs of keys that are not present in the system's internal key table), contact [NetApp Support](#).

11. Return the impaired controller to normal operation by giving back its storage: `storage failover giveback -ofnode impaired_node_name`
12. If automatic giveback was disabled, reenable it: `storage failover modify -node local -auto-giveback true`
13. If AutoSupport is enabled, restore/unsuppress automatic case creation: `system node autosupport invoke -node * -type all -message MAINT=END`

### External key manager (EKM)

1. If the root volume is encrypted with External Key Manager and the console cable is connected to the replacement node, enter `boot_ontap` menu and select option 11.
2. Answer `y` or `n` to the following questions:

Do you have a copy of the `/cfcard/kmip/certs/client.crt` file? {y/n}

Do you have a copy of the `/cfcard/kmip/certs/client.key` file? {y/n}

Do you have a copy of the `/cfcard/kmip/certs/CA.pem` file? {y/n}

OR

Do you have a copy of the `/cfcard/kmip/servers.cfg` file? {y/n}

Do you know the KMIP server address? {y/n}

Do you know the KMIP port? {y/n}



Contact [NetApp Support](#) if you have issues.

3. Supply the information for:
  - The client certificate (`client.crt`) file contents
  - The client key (`client.key`) file contents
  - The KMIP server CA(s) (`CA.pem`) file contents
  - The IP address for the KMIP server
  - The port for the KMIP server
4. Once the system processes, you see the Boot Menu. Select '1' for normal boot.
5. Check the takeover status: `storage failover show`
6. Ensure any core dumps on the repaired node are saved by going to advanced mode `set -privilege advanced` and then run `local partner nosavecore`.
7. Return the impaired controller to normal operation by giving back its storage: `storage failover giveback -ofnode impaired_node_name`
8. If automatic giveback was disabled, reenable it: `storage failover modify -node local -auto-giveback true`
9. If AutoSupport is enabled, restore/unsuppress automatic case creation: `system node autosupport invoke -node * -type all -message MAINT=END`

# Complete controller replacement - AFF A20, AFF A30, and AFF A50

To restore your storage system to full operation, you must verify the LIFs, check cluster health, and return the failed part to NetApp.

## Step 1: Verify LIFs and check cluster health

Before returning the *replacement* node to service, you should verify that the LIFs are on their home ports, check the cluster health, and reset automatic giveback.

### Steps

1. Verify that the logical interfaces are reporting to their home server and ports: `network interface show -is-home false`

If any LIFs are listed as false, revert them to their home ports: `network interface revert -vserver * -lif *`

2. Check the health of your cluster. See the [How to perform a cluster health check with a script in ONTAP KB](#) article for more information.
3. If automatic giveback was disabled, reenable it: `storage failover modify -node local -auto-giveback true`

## Step 2: Return the failed part to NetApp

Return the failed part to NetApp, as described in the RMA instructions shipped with the kit. See the [Part Return and Replacements](#) page for further information.

## Copyright information

Copyright © 2024 NetApp, Inc. All Rights Reserved. Printed in the U.S. No part of this document covered by copyright may be reproduced in any form or by any means—graphic, electronic, or mechanical, including photocopying, recording, taping, or storage in an electronic retrieval system—without prior written permission of the copyright owner.

Software derived from copyrighted NetApp material is subject to the following license and disclaimer:

THIS SOFTWARE IS PROVIDED BY NETAPP “AS IS” AND WITHOUT ANY EXPRESS OR IMPLIED WARRANTIES, INCLUDING, BUT NOT LIMITED TO, THE IMPLIED WARRANTIES OF MERCHANTABILITY AND FITNESS FOR A PARTICULAR PURPOSE, WHICH ARE HEREBY DISCLAIMED. IN NO EVENT SHALL NETAPP BE LIABLE FOR ANY DIRECT, INDIRECT, INCIDENTAL, SPECIAL, EXEMPLARY, OR CONSEQUENTIAL DAMAGES (INCLUDING, BUT NOT LIMITED TO, PROCUREMENT OF SUBSTITUTE GOODS OR SERVICES; LOSS OF USE, DATA, OR PROFITS; OR BUSINESS INTERRUPTION) HOWEVER CAUSED AND ON ANY THEORY OF LIABILITY, WHETHER IN CONTRACT, STRICT LIABILITY, OR TORT (INCLUDING NEGLIGENCE OR OTHERWISE) ARISING IN ANY WAY OUT OF THE USE OF THIS SOFTWARE, EVEN IF ADVISED OF THE POSSIBILITY OF SUCH DAMAGE.

NetApp reserves the right to change any products described herein at any time, and without notice. NetApp assumes no responsibility or liability arising from the use of products described herein, except as expressly agreed to in writing by NetApp. The use or purchase of this product does not convey a license under any patent rights, trademark rights, or any other intellectual property rights of NetApp.

The product described in this manual may be protected by one or more U.S. patents, foreign patents, or pending applications.

LIMITED RIGHTS LEGEND: Use, duplication, or disclosure by the government is subject to restrictions as set forth in subparagraph (b)(3) of the Rights in Technical Data -Noncommercial Items at DFARS 252.227-7013 (FEB 2014) and FAR 52.227-19 (DEC 2007).

Data contained herein pertains to a commercial product and/or commercial service (as defined in FAR 2.101) and is proprietary to NetApp, Inc. All NetApp technical data and computer software provided under this Agreement is commercial in nature and developed solely at private expense. The U.S. Government has a non-exclusive, non-transferrable, nonsublicensable, worldwide, limited irrevocable license to use the Data only in connection with and in support of the U.S. Government contract under which the Data was delivered. Except as provided herein, the Data may not be used, disclosed, reproduced, modified, performed, or displayed without the prior written approval of NetApp, Inc. United States Government license rights for the Department of Defense are limited to those rights identified in DFARS clause 252.227-7015(b) (FEB 2014).

## Trademark information

NETAPP, the NETAPP logo, and the marks listed at <http://www.netapp.com/TM> are trademarks of NetApp, Inc. Other company and product names may be trademarks of their respective owners.