



## **I/O module**

### **Install and maintain**

NetApp  
January 21, 2025

# Table of Contents

- I/O module ..... 1
  - Overview of add and replace I/O module - AFF A20, AFF A30, and AFF A50 ..... 1
  - Add I/O module - AFF A20, AFF A30, and AFF A50 ..... 1
  - Replace I/O module - AFF A20, AFF A30, and AFF A50 ..... 5

# I/O module

## Overview of add and replace I/O module - AFF A20, AFF A30, and AFF A50

You can replace a failed I/O module in your storage system with the same type of I/O module, or with a different type of I/O module. You can also add an I/O module to a storage system with available slots.

- [Add an I/O module](#)

Adding additional I/O modules can improve redundancy, helping to ensure that the storage system remains operational even if one I/O module fails.

- [Replace an I/O module](#)

Replacing a failing I/O module can restore the storage system to its optimal operating state.

## Add I/O module - AFF A20, AFF A30, and AFF A50

You can add an I/O module to your AFF A20, AFF A30, and AFF A50 storage systems when there are slots available or when all slots are fully populated.

### About this task

- If needed, you can turn on the storage system location (blue) LEDs to aid in physically locating the affected storage system. Log into the BMC using SSH and enter the `system location-led on` command.

A storage system has three location LEDs: one on the operator display panel and one on each controller. Location LEDs remain illuminated for 30 minutes.

You can turn them off by entering the `system location-led off` command. If you are unsure if the LEDs are on or off, you can check their state by entering the `system location-led show` command.

## Step 1: Shut down the impaired controller module

To shut down the impaired controller, you must determine the status of the controller and, if necessary, take over the controller so that the healthy controller continues to serve data from the impaired controller storage.

### Before you begin

If you have a cluster with more than two nodes, it must be in quorum. If the cluster is not in quorum or a healthy controller shows false for eligibility and health, you must correct the issue before shutting down the impaired controller; see [Synchronize a node with the cluster](#).

### Steps

1. If AutoSupport is enabled, suppress automatic case creation by invoking an AutoSupport message command:

```
system node autosupport invoke -node * -type all -message MAINT=number_of_hours_downh
```

The following AutoSupport command suppresses automatic case creation for two hours: `cluster1:*>`

```
system node autosupport invoke -node * -type all -message MAINT=2h
```

2. Disable automatic giveback from the console of the healthy controller: `storage failover modify -node local -auto-giveback false`
3. Take the impaired controller to the LOADER prompt:

If the impaired controller is displaying...	Then...
The LOADER prompt	Go to the next step.
Waiting for giveback...	Press Ctrl-C, and then respond <code>y</code> when prompted.
System prompt or password prompt (enter system password)	Halt or take over the impaired controller from the healthy controller: <code>storage failover takeover -ofnode <i>impaired_node_name</i></code>  When the impaired controller shows Waiting for giveback..., press Ctrl-C, and then respond <code>y</code> .

## Step 2: Add the new I/O module

If the storage system has available slots, install the new I/O module into one of the available slots. If all slots are occupied, remove an existing I/O module to make space and then install the new one.

### Before you begin

- Check the [NetApp Hardware Universe](#) to make sure that the new I/O module is compatible with your storage system and version of ONTAP you're running.
- If multiple slots are available, check the slot priorities in [NetApp Hardware Universe](#) and use the best one available for your I/O module.
- All other components in the storage system must be functioning properly; if not, you must contact [NetApp Support](#) before continuing with this procedure.

## Add I/O module to an available slot

You can add a new I/O module into a storage system with available slots.

### Steps

1. If you are not already grounded, properly ground yourself.
2. On the impaired controller, remove the I/O blanking module from the target slot.

Unused I/O slots should have blanking module installed to prevent possible thermal issues.

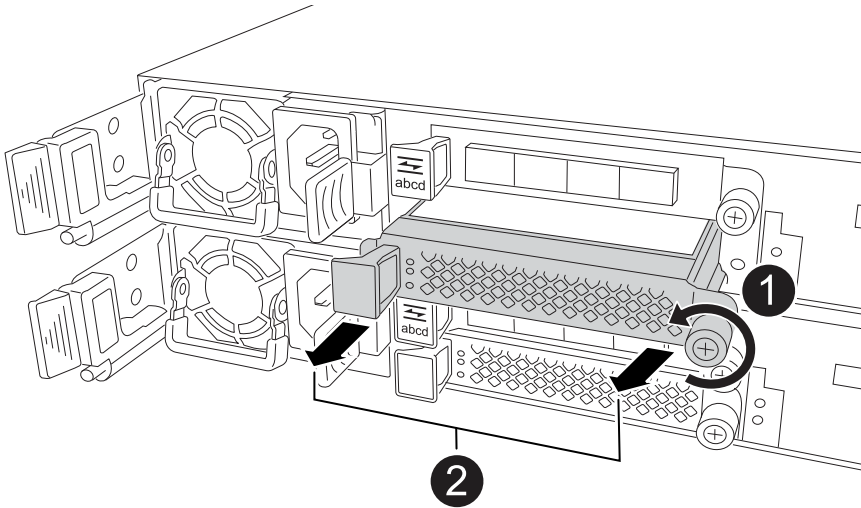

1	On the I/O blanking module, turn the thumbscrew counterclockwise to loosen.
2	Pull the I/O blanking module out of the controller using the tab on the left and the thumbscrew.

3. Install the new I/O module:
  - a. Align the I/O module with the edges of the controller slot opening.
  - b. Gently push the I/O module all the way into the slot, making sure to properly seat the module into the connector.

You can use the tab on the left and the thumbscrew to push in the I/O module.

- c. Turn the thumbscrew clockwise to tighten.

4. Cable the I/O module to the designated devices.

If you installed a storage I/O module, install and cable your NS224 shelves, as described in [Hot-add workflow](#).

5. Reboot the impaired controller from the LOADER prompt: `bye`

Rebooting the impaired controller also reinitializes the I/O modules and other components.

6. Give back the impaired controller from the partner controller: `storage failover giveback -ofnode impaired_node_name`

7. Repeat these steps to add an I/O module to the other controller.
8. Restore automatic giveback from the console of the healthy controller: `storage failover modify -node local -auto-giveback true`
9. If AutoSupport is enabled, restore (unsuppress) automatic case creation: `system node autosupport invoke -node * -type all -message MAINT=END`

### Add I/O module to a fully-populated system

You can add an I/O module to a fully-populated system by removing an existing I/O module and installing a new one in its place.

#### About this task

Make sure you understand the following scenarios for adding a new I/O module to a fully-populated system:

Scenario	Action required
NIC to NIC (same number of ports)	The LIFs will automatically migrate when its controller module is shut down.
NIC to NIC (different number of ports)	Permanently reassign the selected LIFs to a different home port. See <a href="#">Migrating a LIF</a> for more information.
NIC to storage I/O module	Use System Manager to permanently migrate the LIFs to different home ports, as described in <a href="#">Migrating a LIF</a> .

#### Steps

1. If you are not already grounded, properly ground yourself.
2. On the impaired controller, unplug any cabling on the target I/O module.
3. Remove the target I/O module from the controller:

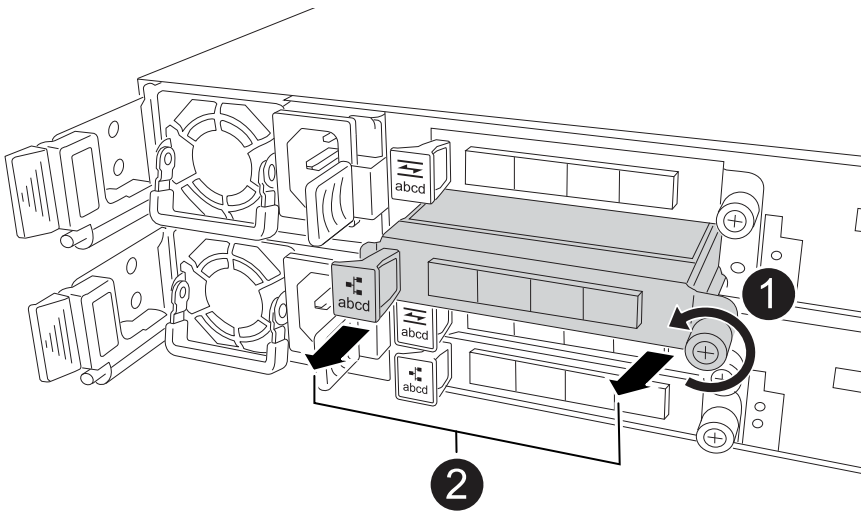

<b>1</b>	Turn the I/O module thumbscrew counterclockwise to loosen.
----------	--

**2**

Pull the I/O module out of the controller using the port label tab on the left and the thumbscrew.

4. Install the new I/O module into the target slot:
  - a. Align the I/O module with the edges of the slot.
  - b. Gently push the I/O module all the way into the slot, making sure to properly seat the module into the connector.

You can use the tab on the left and the thumbscrew to push in the I/O Module.

- c. Turn the thumbscrew clockwise to tighten.

5. Cable the I/O module to the designated devices.

If you installed a storage I/O module, install and cable your NS224 shelves, as described in [Hot-add workflow](#).

6. Repeat the I/O module remove and install steps to add any additional I/O modules in the controller.
7. Reboot the impaired controller from the LOADER prompt: `bye`

Rebooting the impaired controller also reinitializes the I/O modules and other components.

8. Give back the impaired controller from the partner controller: `storage failover giveback -ofnode impaired_node_name`
9. Restore automatic giveback from the console of the healthy controller: `storage failover modify -node local -auto-giveback true`
10. If AutoSupport is enabled, restore (unsuppress) automatic case creation: `system node autosupport invoke -node * -type all -message MAINT=END`
11. If you installed a NIC module, specify the usage mode for each port as *network*: `storage port modify -node *<node name> -port *<port name> -mode network`
12. Repeat these steps for the other controller.

## Replace I/O module - AFF A20, AFF A30, and AFF A50

Use this procedure to replace a failed I/O module.

### Before you begin

All other components in the storage system must be functioning properly; if not, you must contact [NetApp Support](#) before continuing with this procedure.

### About this task

- If needed, you can turn on the storage system location (blue) LEDs to aid in physically locating the affected storage system. Log into the BMC using SSH and enter the `system location-led on` command.

A storage system has three location LEDs: one on the operator display panel and one on each controller. Location LEDs remain illuminated for 30 minutes.

You can turn them off by entering the `system location-led off` command. If you are unsure if the

LEDs are on or off, you can check their state by entering the `system location-led show` command.

## Step 1: Shut down the impaired controller

Shut down or take over the impaired controller.

To shut down the impaired controller, you must determine the status of the controller and, if necessary, take over the controller so that the healthy controller continues to serve data from the impaired controller storage.

### About this task

- If you have a SAN system, you must have checked event messages (`cluster kernel-service show`) for the impaired controller SCSI blade. The `cluster kernel-service show` command (from `priv advanced` mode) displays the node name, [quorum status](#) of that node, availability status of that node, and operational status of that node.

Each SCSI-blade process should be in quorum with the other nodes in the cluster. Any issues must be resolved before you proceed with the replacement.

- If you have a cluster with more than two nodes, it must be in quorum. If the cluster is not in quorum or a healthy controller shows `false` for eligibility and health, you must correct the issue before shutting down the impaired controller; see [Synchronize a node with the cluster](#).

### Steps

1. If AutoSupport is enabled, suppress automatic case creation by invoking an AutoSupport message:  
`system node autosupport invoke -node * -type all -message MAINT=<# of hours>h`

The following AutoSupport message suppresses automatic case creation for two hours: `cluster1:>`  
`system node autosupport invoke -node * -type all -message MAINT=2h`

2. Disable automatic giveback from the console of the healthy controller: `storage failover modify -node local -auto-giveback false`



When you see *Do you want to disable auto-giveback?*, enter *y*.

3. Take the impaired controller to the LOADER prompt:

If the impaired controller is displaying...	Then...
The LOADER prompt	Go to the next step.
Waiting for giveback...	Press Ctrl-C, and then respond <i>y</i> when prompted.
System prompt or password prompt	Take over or halt the impaired controller from the healthy controller: <code>storage failover takeover -ofnode impaired_node_name</code>  When the impaired controller shows Waiting for giveback..., press Ctrl-C, and then respond <i>y</i> .



## Step 2: Replace a failed I/O module

To replace a failed I/O module, locate it in the controller and follow the specific sequence of steps.

1. If you are not already grounded, properly ground yourself.
2. Unplug cabling from the failed I/O module.

Make sure to label the cables so that you know where they came from.

3. Remove the failed I/O module from the controller:

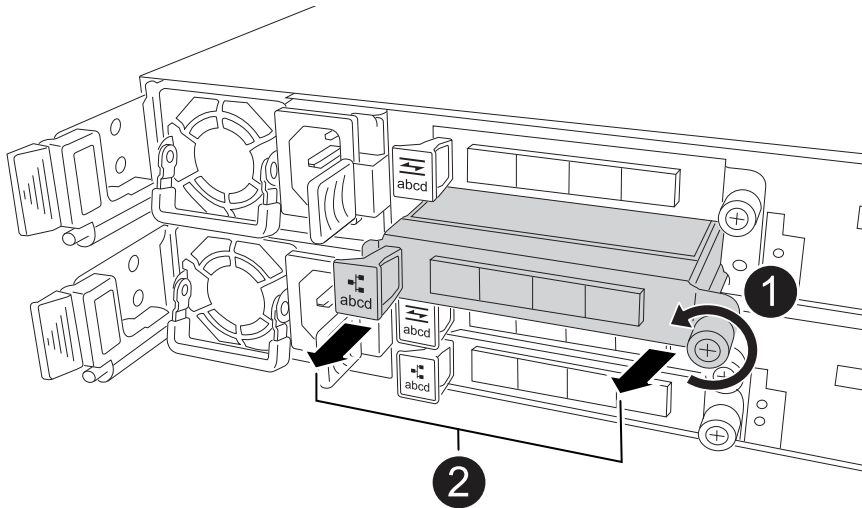

<b>1</b>	Turn the I/O module thumbscrew counterclockwise to loosen.
<b>2</b>	Pull the I/O module out of the controller using the port label tab on the left and the thumbscrew.

4. Install the replacement I/O module into the target slot:
  - a. Align the I/O module with the edges of the slot.
  - b. Gently push the I/O module all the way into the slot, making sure to properly seat the module into the connector.

You can use the tab on the left and the thumbscrew to push in the I/O Module.

- c. Turn the thumbscrew clockwise to tighten.

5. Cable the I/O module.

## Step 3: Reboot the controller

After you replace an I/O module, you must reboot the controller.

### Steps

1. Reboot the controller from the LOADER prompt: `bye`

Rebooting the impaired controller also reinitializes the I/O modules and other components.

2. Return the node to normal operation: `storage failover giveback -ofnode impaired_node_name`
3. Restore automatic giveback from the console of the healthy controller: `storage failover modify -node local -auto-giveback true`

#### **Step 4: Return the failed part to NetApp**

Return the failed part to NetApp, as described in the RMA instructions shipped with the kit. See the [Part Return and Replacements](#) page for further information.

## Copyright information

Copyright © 2025 NetApp, Inc. All Rights Reserved. Printed in the U.S. No part of this document covered by copyright may be reproduced in any form or by any means—graphic, electronic, or mechanical, including photocopying, recording, taping, or storage in an electronic retrieval system—without prior written permission of the copyright owner.

Software derived from copyrighted NetApp material is subject to the following license and disclaimer:

THIS SOFTWARE IS PROVIDED BY NETAPP “AS IS” AND WITHOUT ANY EXPRESS OR IMPLIED WARRANTIES, INCLUDING, BUT NOT LIMITED TO, THE IMPLIED WARRANTIES OF MERCHANTABILITY AND FITNESS FOR A PARTICULAR PURPOSE, WHICH ARE HEREBY DISCLAIMED. IN NO EVENT SHALL NETAPP BE LIABLE FOR ANY DIRECT, INDIRECT, INCIDENTAL, SPECIAL, EXEMPLARY, OR CONSEQUENTIAL DAMAGES (INCLUDING, BUT NOT LIMITED TO, PROCUREMENT OF SUBSTITUTE GOODS OR SERVICES; LOSS OF USE, DATA, OR PROFITS; OR BUSINESS INTERRUPTION) HOWEVER CAUSED AND ON ANY THEORY OF LIABILITY, WHETHER IN CONTRACT, STRICT LIABILITY, OR TORT (INCLUDING NEGLIGENCE OR OTHERWISE) ARISING IN ANY WAY OUT OF THE USE OF THIS SOFTWARE, EVEN IF ADVISED OF THE POSSIBILITY OF SUCH DAMAGE.

NetApp reserves the right to change any products described herein at any time, and without notice. NetApp assumes no responsibility or liability arising from the use of products described herein, except as expressly agreed to in writing by NetApp. The use or purchase of this product does not convey a license under any patent rights, trademark rights, or any other intellectual property rights of NetApp.

The product described in this manual may be protected by one or more U.S. patents, foreign patents, or pending applications.

LIMITED RIGHTS LEGEND: Use, duplication, or disclosure by the government is subject to restrictions as set forth in subparagraph (b)(3) of the Rights in Technical Data -Noncommercial Items at DFARS 252.227-7013 (FEB 2014) and FAR 52.227-19 (DEC 2007).

Data contained herein pertains to a commercial product and/or commercial service (as defined in FAR 2.101) and is proprietary to NetApp, Inc. All NetApp technical data and computer software provided under this Agreement is commercial in nature and developed solely at private expense. The U.S. Government has a non-exclusive, non-transferrable, nonsublicensable, worldwide, limited irrevocable license to use the Data only in connection with and in support of the U.S. Government contract under which the Data was delivered. Except as provided herein, the Data may not be used, disclosed, reproduced, modified, performed, or displayed without the prior written approval of NetApp, Inc. United States Government license rights for the Department of Defense are limited to those rights identified in DFARS clause 252.227-7015(b) (FEB 2014).

## Trademark information

NETAPP, the NETAPP logo, and the marks listed at <http://www.netapp.com/TM> are trademarks of NetApp, Inc. Other company and product names may be trademarks of their respective owners.