



Chassis

Install and maintain

NetApp
December 18, 2024

Table of Contents

- Chassis 1
 - Chassis replacement workflow - AFF C30 and AFF C60 1
 - Requirements and considerations - AFF C30 and AFF C60 1
 - Shut down the controllers - AFF C30 and AFF C60 2
 - Replace the chassis - AFF C30 and AFF C60 3
 - Complete chassis replacement - AFF C30 and AFF C60 8

Chassis

Chassis replacement workflow - AFF C30 and AFF C60

Follow these workflow steps to replace your chassis.

1

Review the chassis replace requirements

To replace the chassis, you must meet certain requirements.

2

Shut down the controllers

Shut down the controllers so you can perform maintenance on the chassis.

3

Replace the chassis

Replacing the chassis includes moving the power supplies, hard drives, and controller module from the impaired chassis to the new chassis, and swapping out the impaired chassis with the new chassis of the same model as the impaired chassis.

4

Complete chassis replacement

Verify the HA state of the chassis and return the failed part to NetApp.

Requirements and considerations - AFF C30 and AFF C60

Before replacing the chassis, make sure to review the following requirements and considerations.

Requirements

- The replacement chassis must be the same model as the impaired chassis. This procedure is for a like-for-like replacement, not for an upgrade.
- All other components in the storage system must be functioning properly; if not, you must contact [NetApp Support](#) before continuing with this procedure.

Considerations

- **The chassis replacement procedure is disruptive.** For a two-node cluster, you will have a complete service outage and a partial outage in a multi-node cluster.
- You can use the chassis replacement procedure with all versions of ONTAP supported by your storage system.
- The chassis replacement procedure is written with the assumption that you are moving the bezel, drives, any drive blanks, and controllers to the new chassis.
- If needed, you can turn on the storage system location (blue) LEDs to aid in physically locating the affected storage system. Log into the BMC using SSH and enter the `system location-led on` command.

A storage system has three location LEDs: one on the operator display panel and one on each controller. Location LEDs remain illuminated for 30 minutes.

You can turn them off by entering the `system location-led off` command. If you are unsure if the LEDs are on or off, you can check their state by entering the `system location-led show` command.

Shut down the controllers - AFF C30 and AFF C60

Shut down the controllers so you can perform maintenance on the chassis.

This procedure is for systems with two node configurations. If you have a system with more than two nodes, see [How to perform a graceful shutdown and power up of one HA pair in a four node cluster](#).

Before you begin

- Stop all clients/host from accessing data on the NetApp system.
- Suspend external backup jobs.
- Make sure you have the necessary permissions and credentials:
 - Local administrator credentials for ONTAP.
 - NetApp onboard key management (OKM) cluster-wide passphrase if using storage encryption or NVE/NAE.
 - BMC accessibility for each controller.
- Make sure you have the necessary tools and equipment for the replacement.
- As a best practice before shutdown, you should:
 - Perform additional [system health checks](#).
 - Upgrade ONTAP to a recommended release for the system.
 - Resolve any [Active IQ Wellness Alerts and Risks](#). Make note of any faults presently on the system, such as LEDs on the system components.

Steps

1. Log into the cluster through SSH or log in from any node in the cluster using a local console cable and a laptop/console.
2. Turn off AutoSupport and indicate how long you expect the system to be offline:

```
system node autosupport invoke -node * -type all -message "MAINT=8h Power Maintenance"
```

3. Identify the SP/BMC address of all nodes:

```
system service-processor show -node * -fields address
```

4. Exit the cluster shell: `exit`
5. Log into SP/BMC over SSH using the IP address of any of the nodes listed in the output from the previous step.

If you are using a console/laptop, log into the controller using the same cluster administrator credentials.



Open an SSH session to every SP/BMC connection so that you can monitor progress.

6. Halt the two nodes located in the impaired chassis:

```
system node halt -node <node1>,<node2> -skip-lif-migration-before-shutdown
true -ignore-quorum-warnings true -inhibit-takeover true
```



For clusters using SnapMirror synchronous operating in StrictSync mode: `system node halt -node <node1>,<node2> -skip-lif-migration-before-shutdown true -ignore-quorum-warnings true -inhibit-takeover true -ignore-strict-sync-warnings true`

7. Enter **y** for each controller in the cluster when you see *Warning: Are you sure you want to halt node "cluster <node-name> number"? {y|n}*:

8. Wait for each controller to halt and display the LOADER prompt.

Replace the chassis - AFF C30 and AFF C60

Move the drives, any drive blanks, controllers, and bezel from the impaired chassis to the replacement chassis (of the same model), and then replace the impaired chassis within the equipment rack or system cabinet.

Step 1: Remove the controller

You must remove the controller from the chassis when you replace the controller or replace a component inside the controller.

Before you begin

All other components in the storage system must be functioning properly; if not, you must contact [NetApp Support](#) before continuing with this procedure.

Steps

1. On the impaired controller, make sure the NV LED is off.

When the NV LED is off, destaging is complete and it is safe to remove the impaired controller.



If the NV LED is flashing (green), destage is in progress. You must wait for the NV LED to turn off. However, if the flashing continues for longer than five minutes, contact [NetApp Support](#) before continuing with this procedure.

The NV LED is located next to the NV icon on the controller.

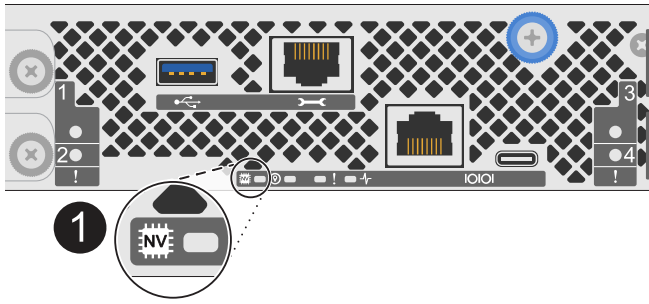

1	NV icon and LED on the controller
----------	-----------------------------------

2. If you are not already grounded, properly ground yourself.
3. Disconnect the power on the impaired controller:

 Power supplies (PSUs) do not have a power switch.

If you are disconnecting a...	Then...
AC PSU	<ol style="list-style-type: none"> 1. Open the power cord retainer. 2. Unplug the power cord from the PSU and set it aside.
DC PSU	<ol style="list-style-type: none"> 1. Unscrew the two thumb screws on the D-SUB DC power cord connector. 2. Unplug the power cord from the PSU and set it aside.

4. Unplug all cables from the impaired controller.

Keep track of where the cables were connected.

5. Remove the impaired controller:

The following illustration shows the operation of the controller handles (from the left side of the controller) when removing a controller:

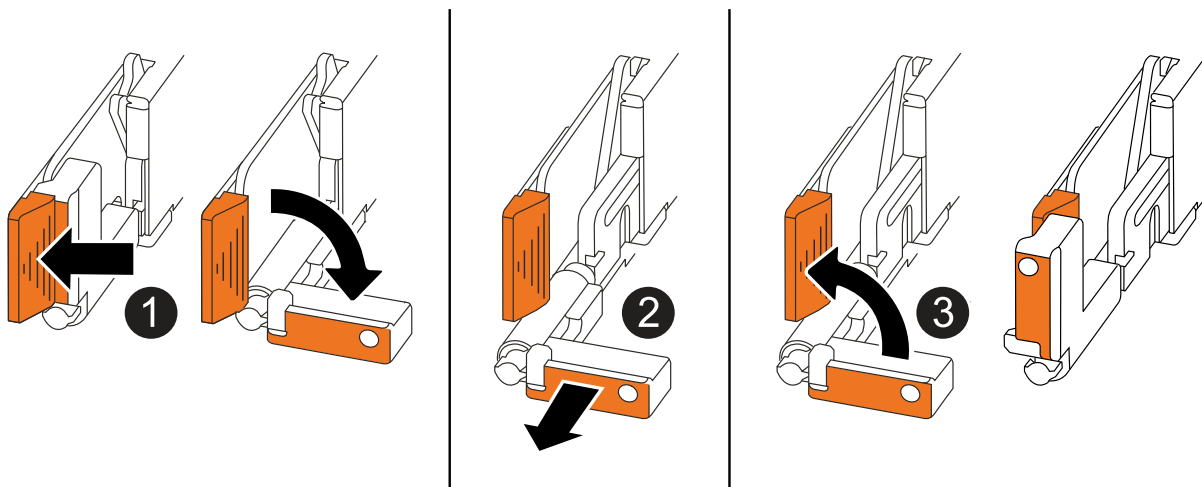

1	On both ends of the controller, push the vertical locking tabs outward to release the handles.
2	<ul style="list-style-type: none"> • Pull the handles towards you to unseat the controller from the midplane. <p>As you pull, the handles extend out from the controller and then you feel some resistance, keep pulling.</p> <ul style="list-style-type: none"> • Slide the controller out of the chassis while supporting the bottom of the controller, and place it on a flat, stable surface.
3	If needed, rotate the handles upright (next to the tabs) to move them out of the way.

6. Repeat these steps for the other controller in the chassis.

Step 2: Remove the drives from the impaired chassis

You need to remove all of the drives and any drive blanks from the impaired chassis so that later in the procedure you can install them in the replacement chassis.

1. Gently remove the bezel from the front of the storage system.
2. Remove the drives and any drive blanks:



Keep track of what drive bay each drive and drive blank was removed from because they must be installed in the same drive bays in the replacement chassis.

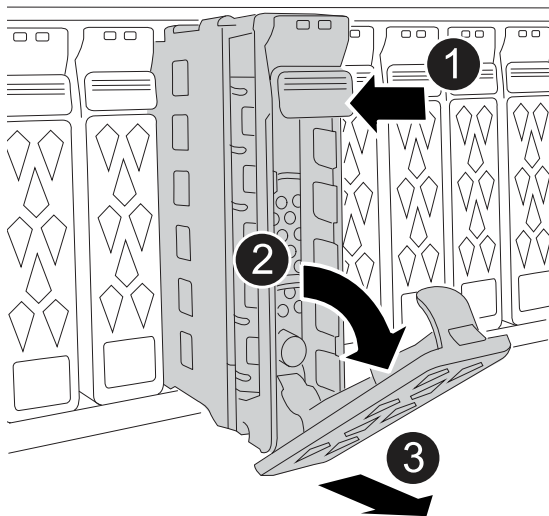

1	Press the release button on the drive face to open the cam handle.
2	Rotate the cam handle downward to disengage the drive from the midplane.

3

Slide the drive out of the drive bay using the cam handle and supporting the drive with your other hand.

When removing a drive, always use two hands to support its weight.



Because drives are fragile, minimize handling to avoid damaging them.

3. Set the drives aside on a static-free cart or table.

Step 3: Replace the chassis from within the equipment rack or system cabinet

You remove the impaired chassis from the equipment rack or system cabinet, install the replacement chassis, install the drives, any drive blanks and then install the bezel.

1. Remove the screws from the impaired chassis mount points.

Set the screws aside to use later in this procedure.



If the storage system shipped in a NetApp system cabinet, you must remove additional screws at the rear of the chassis before the chassis can be removed.

2. Using two people or a power lift, remove the impaired chassis from the equipment rack or system cabinet by sliding it off the rails, and then set it aside.
3. Using two people, install the replacement chassis into the equipment rack or system cabinet by sliding it onto the rails.
4. Secure the front of the replacement chassis to the equipment rack or system cabinet using the screws you removed from the impaired chassis.

Step 4: Install the controllers

Install the controllers into the replacement chassis and reboot them.

About this task

The following illustration shows the operation of the controller handles (from the left side of a controller) when installing a controller, and can be used as a reference for the rest of the controller installation steps.

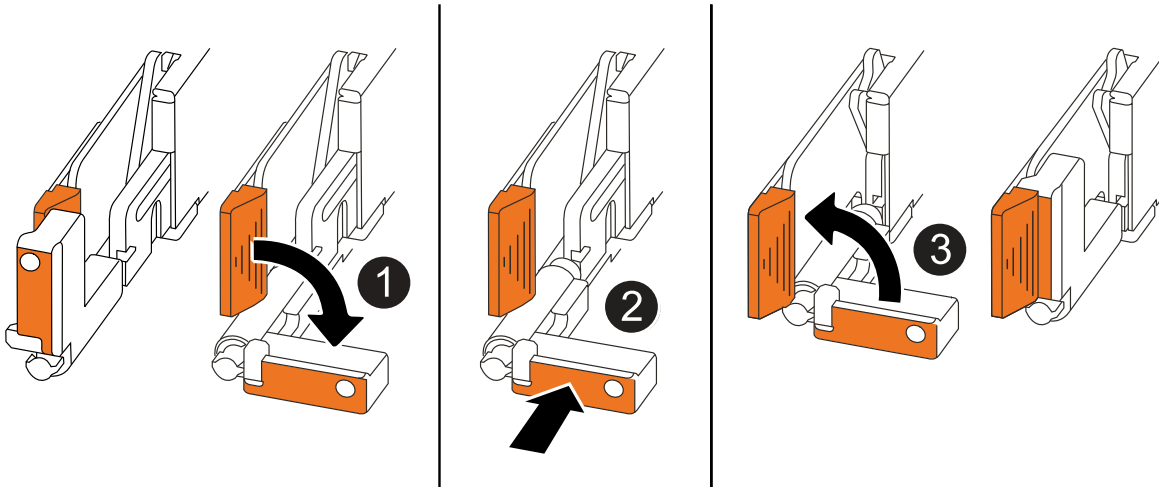

1	If you rotated the controller handles upright (next to the tabs) to move them out of the way, rotate them down to the horizontal position.
2	Push the handles to reinsert the controller into the chassis and push until the controller is fully seated.
3	Rotate the handles to the upright position and lock in place with the locking tabs.

1. Insert one of the controllers into the chassis:

- a. Align the back of the controller with the opening in the chassis.
- b. Firmly push on the handles until the controller meets the midplane and is fully seated in the chassis.



Do not use excessive force when sliding the controller into the chassis; it could damage the connectors.

- c. Rotate the controller handles up and lock in place with the tabs.

2. Recable the controller, as needed, except for the power cords.

3. Repeat these steps to install the second controller into the chassis.

4. Install the drives and any drive blanks you removed from the impaired chassis into the replacement chassis:



The drives and drive blanks must be installed in the same drive bays in the replacement chassis.

- a. With the cam handle in the open position, use both hands to insert the drive.
- b. Gently push until the drive stops.
- c. Close the cam handle so that the drive is fully seated into the midplane and the handle clicks into place.

Be sure to close the cam handle slowly so that it aligns correctly with the face of the drive.

- d. Repeat the process for the remaining drives.

5. Install the bezel.
6. Reconnect the power cords to the power supplies (PSU) in the controllers.

Once power is restored to a PSU, the status LED should be green.



The controllers begin to boot as soon as the power is restored.

If you are reconnecting a...	Then...
AC PSU	<ol style="list-style-type: none"> 1. Plug the power cord into the PSU. 2. Secure the power cord with the power cord retainer.
DC PSU	<ol style="list-style-type: none"> 1. Plug the D-SUB DC power cord connector into the PSU. 2. Tighten the two thumb screws to secure the D-SUB DC power cord connector to the PSU.

7. If controllers boot to the LOADER prompt, reboot the controllers:

```
boot_ontap
```

8. Turn AutoSupport back on:

```
system node autosupport invoke -node * -type all -message MAINT=END
```

Complete chassis replacement - AFF C30 and AFF C60

You must verify the HA state of the chassis and return the failed part to NetApp, as described in the RMA instructions shipped with the kit.

Step 1: Verify and set the HA state of the chassis

You must verify the HA state of the chassis, and, if necessary, update the state to match your storage system configuration.

1. In Maintenance mode, from either controller, display the HA state of the local controller and chassis:

```
ha-config show
```

The HA state should be the same for all components.

2. If the displayed system state for the chassis does not match your storage system configuration:
 - a. Set the HA state for the chassis:

```
ha-config modify chassis HA-state
```

The value for HA-state should be *ha*.

- b. Confirm that the setting has changed:

```
ha-config show
```

3. If you have not already done so, recable the rest of your storage system.

Step 2: Return the failed part to NetApp

Return the failed part to NetApp, as described in the RMA instructions shipped with the kit. See the [Part Return and Replacements](#) page for further information.

Copyright information

Copyright © 2024 NetApp, Inc. All Rights Reserved. Printed in the U.S. No part of this document covered by copyright may be reproduced in any form or by any means—graphic, electronic, or mechanical, including photocopying, recording, taping, or storage in an electronic retrieval system—without prior written permission of the copyright owner.

Software derived from copyrighted NetApp material is subject to the following license and disclaimer:

THIS SOFTWARE IS PROVIDED BY NETAPP “AS IS” AND WITHOUT ANY EXPRESS OR IMPLIED WARRANTIES, INCLUDING, BUT NOT LIMITED TO, THE IMPLIED WARRANTIES OF MERCHANTABILITY AND FITNESS FOR A PARTICULAR PURPOSE, WHICH ARE HEREBY DISCLAIMED. IN NO EVENT SHALL NETAPP BE LIABLE FOR ANY DIRECT, INDIRECT, INCIDENTAL, SPECIAL, EXEMPLARY, OR CONSEQUENTIAL DAMAGES (INCLUDING, BUT NOT LIMITED TO, PROCUREMENT OF SUBSTITUTE GOODS OR SERVICES; LOSS OF USE, DATA, OR PROFITS; OR BUSINESS INTERRUPTION) HOWEVER CAUSED AND ON ANY THEORY OF LIABILITY, WHETHER IN CONTRACT, STRICT LIABILITY, OR TORT (INCLUDING NEGLIGENCE OR OTHERWISE) ARISING IN ANY WAY OUT OF THE USE OF THIS SOFTWARE, EVEN IF ADVISED OF THE POSSIBILITY OF SUCH DAMAGE.

NetApp reserves the right to change any products described herein at any time, and without notice. NetApp assumes no responsibility or liability arising from the use of products described herein, except as expressly agreed to in writing by NetApp. The use or purchase of this product does not convey a license under any patent rights, trademark rights, or any other intellectual property rights of NetApp.

The product described in this manual may be protected by one or more U.S. patents, foreign patents, or pending applications.

LIMITED RIGHTS LEGEND: Use, duplication, or disclosure by the government is subject to restrictions as set forth in subparagraph (b)(3) of the Rights in Technical Data -Noncommercial Items at DFARS 252.227-7013 (FEB 2014) and FAR 52.227-19 (DEC 2007).

Data contained herein pertains to a commercial product and/or commercial service (as defined in FAR 2.101) and is proprietary to NetApp, Inc. All NetApp technical data and computer software provided under this Agreement is commercial in nature and developed solely at private expense. The U.S. Government has a non-exclusive, non-transferrable, nonsublicensable, worldwide, limited irrevocable license to use the Data only in connection with and in support of the U.S. Government contract under which the Data was delivered. Except as provided herein, the Data may not be used, disclosed, reproduced, modified, performed, or displayed without the prior written approval of NetApp, Inc. United States Government license rights for the Department of Defense are limited to those rights identified in DFARS clause 252.227-7015(b) (FEB 2014).

Trademark information

NETAPP, the NETAPP logo, and the marks listed at <http://www.netapp.com/TM> are trademarks of NetApp, Inc. Other company and product names may be trademarks of their respective owners.