



Install and setup

Install and maintain

NetApp
December 18, 2024

Table of Contents

- Install and setup 1
 - Installation and setup workflow - AFF C30 and AFF C60 1
 - Installation requirements and considerations - AFF C30 and AFF C60 1
 - Prepare to install - AFF C30 and AFF C60 2
 - Install the hardware - AFF C30 and AFF C60 4
 - Cable the hardware - AFF C30 and AFF C60 5
 - Power on the storage system - AFF C30 and AFF C60 12
 - Complete storage system setup and configuration - AFF C30 and AFF C60 15

Install and setup

Installation and setup workflow - AFF C30 and AFF C60

To install and set up your AFF C30 or AFF C60 storage system, you must review the installation requirements and considerations, prepare your site, install and cable the hardware components, power on the storage system, and set up the ONTAP cluster.

1

Review the installation requirements and considerations

Before installing your storage system, your storage system must meet the installation requirements and you must review the installation considerations.

2

Prepare for installation

To prepare for install, you need to get the site ready, check the environmental and electrical requirements, and ensure there's enough rack space. Then, unpack the equipment, compare its contents to the packing slip, and register the hardware to access support benefits.

3

Install the hardware

To install the hardware, install the rail kits for your storage system and shelves, and then install and secure your storage system and shelves in the cabinet or telco rack.

4

Cable the hardware

To cable the hardware, connect the controllers to your network and then to your shelves.

5

Power on the storage system

To power on your storage system, power on each shelf and assign a unique shelf ID as needed, and then power on the controllers.

6

Complete storage system setup

To complete the setup of your storage system, access ONTAP System Manager by pointing a browser to the controller's IP address. A setup wizard helps you complete cluster configuration for your storage system.

Installation requirements and considerations - AFF C30 and AFF C60

Review the requirements and considerations for your AFF C30 or AFF C60 storage system.

Equipment needed for install

To install your storage system, you need the following equipment and tools.

- Access to a Web browser to configure your storage system
- Electrostatic discharge (ESD) strap
- Flashlight
- Laptop or console with a USB/serial connection
- Paperclip or narrow tipped ball point pen for setting NS224 storage shelf IDs
- Phillips #2 screwdriver

Lifting precautions

Storage systems and shelves are heavy. Exercise caution when lifting and moving these items.

Storage system weight

Take the necessary precautions when moving or lifting your storage system.

An A20, A30, or an A50 storage system can weigh up to 61.5 lbs (27.9 kg). To lift the storage system, use two people or a hydraulic lift.

Shelf weight

Take the necessary precautions when moving or lifting your shelf.

An NS224 shelf with NSM100B modules can weigh up to 56.8 lbs (25.8 kg). To lift the shelf, use two people or a hydraulic lift. Keep all components in the shelf (both front and rear) to prevent unbalancing the shelf weight.

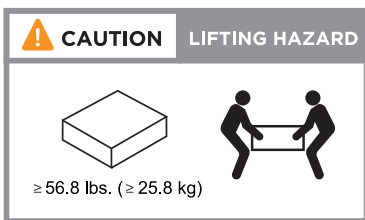

Related information

- [Safety information and regulatory notices](#)

What's next?

After you've reviewed the installation requirements and considerations for your storage system, you [prepare for installation](#).

Prepare to install - AFF C30 and AFF C60

Prepare to install your AFF C30 or AFF C60 storage system by getting the site ready, unpacking the boxes and comparing the contents of the boxes to the packing slip, and registering the storage system to access support benefits.

Step 1: Prepare the site

To install your storage system, ensure that the site and the cabinet or rack that you plan to use meet specifications for your configuration.

Steps

1. Use [NetApp Hardware Universe](#) to confirm that your site meets the environmental and electrical requirements for your storage system.
2. Make sure you have adequate cabinet or rack space for your storage system, shelves, and any switches:
 - 2U for a storage system
 - 2U for each NS224 storage shelf
 - 1U for most switches
3. Install any required network switches.

See the [Switch documentation](#) for installation instructions and [NetApp Hardware Universe](#) for compatibility information.

Step 2: Unpack the boxes

After you've ensured that the site and the cabinet or rack that you plan to use for your storage system meet the required specifications, unpack all boxes and compare the contents to the items on the packing slip.

Steps

1. Carefully open all the boxes and lay out the contents in an organized manner.
2. Compare the contents you've unpacked with the list on the packing slip.



You can get your packing list by scanning the QR code on the side of the shipping carton.

The following items are some of the contents you might see in the boxes.

Ensure that everything in the boxes matches the list on the packing slip. If there are any discrepancies, note them down for further action.

Hardware

- Bezel
- Storage system
- Rail kits with instructions (optional)
- Storage shelf (if you ordered additional storage)

Cables

- Management Ethernet cables (RJ-45 cables)
- Network cables
- Power cords
- Storage cables (if you ordered additional storage)
- USB-C serial console cable

Step 3: Register your storage system

After you've ensured that your site meets the requirements for your storage system specifications, and you've

verified that you have all the parts you ordered, you should register your storage system.

Steps

1. Locate the System Serial Numbers (SSN) for every controller being installed. You can find the serial numbers in the following locations:
2. You can find the serial numbers in the following locations:
 - On the packing slip
 - In your confirmation email
 - On each controller



3. Go to the [NetApp Support Site](#).
4. Determine whether you need to register your storage system:

If you are a...	Follow these steps...
Existing NetApp customer	<ol style="list-style-type: none">a. Sign in with your username and password.b. Select Systems > My Systems.c. Confirm that the new serial numbers are listed.d. If it is not, follow the instructions for new NetApp customers.
New NetApp customer	<ol style="list-style-type: none">a. Click Register Now, and create an account.b. Select Systems > Register Systems.c. Enter the storage system's serial numbers and requested details. <p>After your registration is approved, you can download any required software. The approval process might take up to 24 hours.</p>

What's next?

After you've prepared to install your storage system, you [install the hardware for your storage system](#).

Install the hardware - AFF C30 and AFF C60

After you prepare to install your AFF C30 or AFF C60 storage system, install the hardware for the storage system. First, install the rail kits. Then install and secure your storage system in a cabinet or telco rack.

Skip this step if your storage system came in a cabinet.

Before you begin

- Make sure you have the instructions packaged with the rail kit.
- Be aware of the safety concerns associated with the weight of the storage system and shelf.

- Understand that the airflow through the storage system enters from the front where the bezel or end caps are installed and exhausts out the rear where the ports are located.

Steps

1. Install the rail kits for your storage system and shelves as needed, using the instructions included with the kits.
2. Install and secure your storage system in the cabinet or telco rack:
 - a. Position the storage system onto the rails in the middle of the cabinet or telco rack, and then support the storage system from the bottom and slide it into place.
 - b. Secure the storage system to the cabinet or telco rack using the included mounting screws.
3. Attach the bezel to the front of the storage system.
4. Install and secure the shelf as needed.
 - a. Position the back of the shelf onto the rails, and then support the shelf from the bottom and slide it into the cabinet or telco rack.

If you are installing multiple shelves, place the first shelf directly above the controllers. Place the second shelf directly under the controllers. Repeat this pattern for any additional shelves.

- b. Secure the shelf to the cabinet or telco rack using the included mounting screws.

What's next?

After you've installed the hardware for your storage system, you [cable the hardware](#).

Cable the hardware - AFF C30 and AFF C60

After you install your AFF C30 or AFF C60 storage system hardware, cable the controllers to the network and shelves.

Before you begin

Contact your network administrator for information about connecting the storage system to your network switches.

About this task

- The cluster/HA and host network cabling procedures show common configurations. Keep in mind that the specific cabling depends on the components ordered for your storage system. For comprehensive configuration and slot priority details, see [NetApp Hardware Universe](#).
- The cabling graphics have arrow icons showing the proper orientation (up or down) of the cable connector pull-tab when inserting a connector into a port.

As you insert the connector, you should feel it click into place; if you do not feel it click, remove it, turn it over and try again.

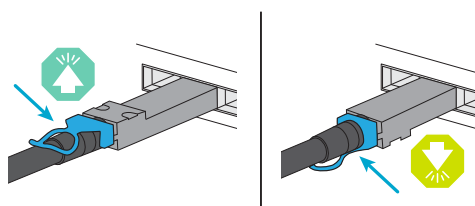

- If cabling to an optical switch, insert the optical transceiver into the controller port before cabling to the switch port.

Step 1: Cable the cluster/HA connections

Cable the controllers to your ONTAP cluster. This procedure differs depending on your storage system model and I/O module configuration.

Switchless cluster cabling

Cable the controllers to each other to create the ONTAP cluster connections.

AFF A30 or A50 with two 2-port 100GbE I/O modules

The I/O module ports in slot 2 and 4 are 40/100GbE ports.???? Does this apply only to 30-50, if yes leave the 2 notes where the are, but if applies to all 3, then move it yo new paragraph below section lead text.????

Steps

1. Cable the Cluster/HA interconnect connections:



The cluster interconnect traffic and the HA traffic share the same physical ports.

- a. Cable controller A port e2a to controller B port e2a.
- b. Cable controller A port e4a to controller B port e4a.



Ports e2b and e4b on the I/O modules in slots 2 and 4 are unused and available for front-end (host network) connectivity, if needed.

Cluster/HA interconnect cables



Controller A

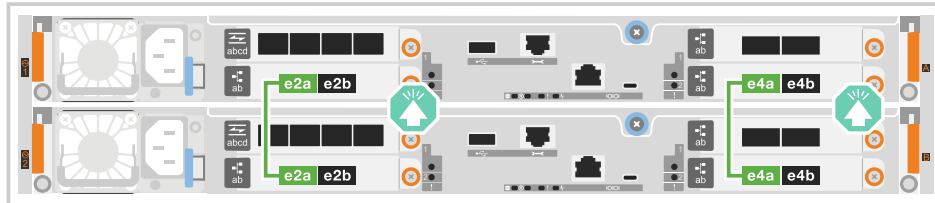

Controller B

AFF A30 or A50 with one 2-port 100GbE I/O module

The I/O module ports in slot 2 and 4 are 40/100GbE ports.????

Steps

1. Cable the Cluster/HA interconnect connections:



The cluster interconnect traffic and the HA traffic share the same physical ports.

- a. Cable controller A port e4a to controller B port e4a.
- b. Cable controller A port e4b to controller B port e4b.

Cluster/HA interconnect cables



Controller A

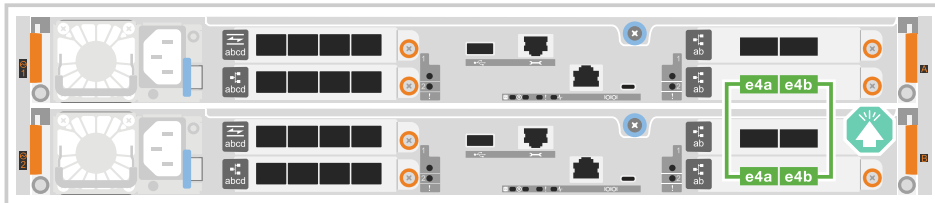

Controller B

AFF A20 with one 2-port 10/25GbE I/O module

Add example



+

+

Switched cluster cabling

Cable the controllers to the cluster network switches to create the ONTAP cluster connections.

AFF A30 or A50 with two 2-port 100GbE I/O modules

Add example

Add note: The 40/100GbE ports e2b and e4b on the I/O modules in slots 2 and 4 are unused and available for front-end connectivity, if needed.

AFF A30 or A50 with one 2-port 100GbE I/O module

Steps

1. Cable the controllers to the cluster network switches:



The cluster interconnect traffic and the HA traffic share the same physical ports.

- a. Cable Controller A port e4a and Controller B port e4a to cluster network switch A.
- b. Cable Controller A port e4b and Controller B port e4b to cluster network switch B.

Cluster/HA interconnect cables

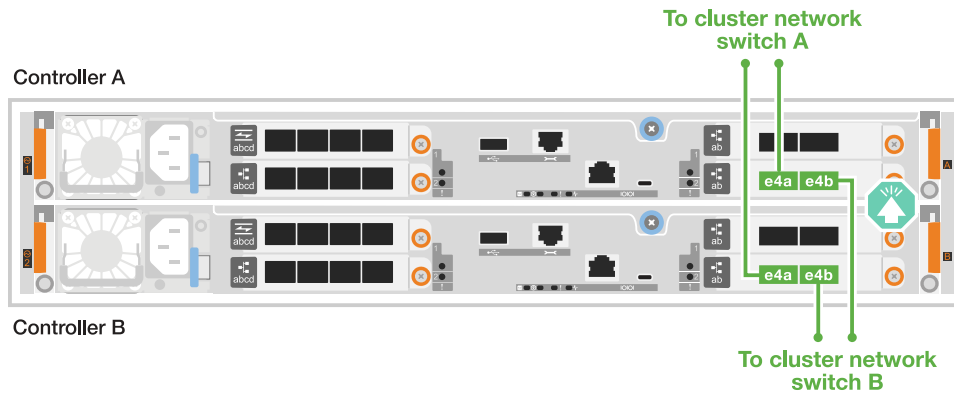

AFF A20 with one 2-port 10/25GbE I/O module

Add example

Step 2: Cable the host network connections

Cable the controllers to your host network. This procedure differs depending on your storage system model and I/O module configuration. Host connectivity is 40/100 GbE.???

AFF A30 or A50 with two 2-port 100GbE I/O modules

Text

AFF A30 or A50 with one 2-port 100GbE I/O module

1. Cable the host network connections.

The following substeps are examples of optional host network cabling. If needed, see [NetApp Hardware Universe](#) for your specific storage system configuration.

- a. Optional: Cable to 40/100GbE host network switches.

Cable ports e2a, e2b, e2c and e2d on each controller to the Ethernet host network switches.

40/100 GbE cables

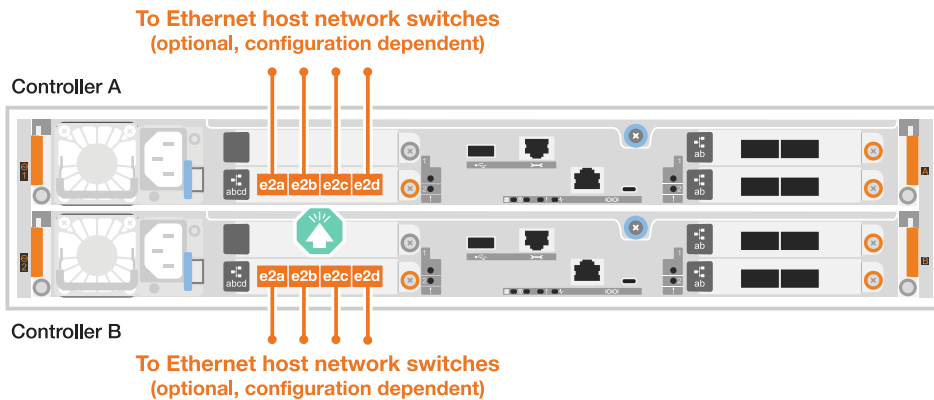

- b. Optional: Cable to FC host network switches.

Cable ports 1a, 1b, 1c and 1d on each controller to the FC host network switches.

64 Gb/s FC cables

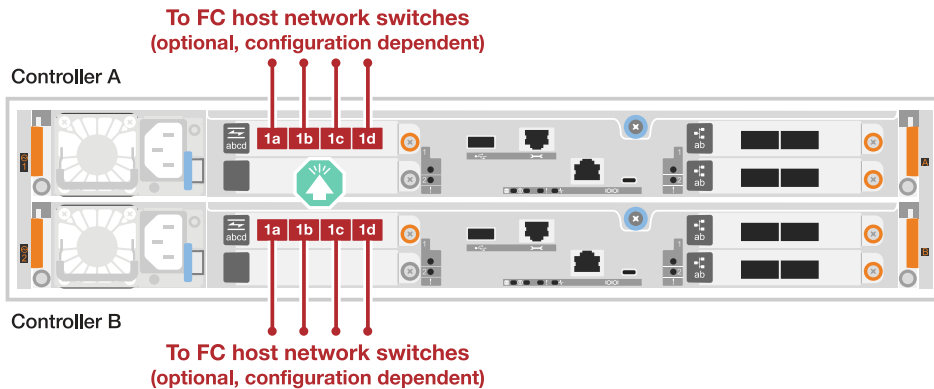

AFF A20 with one 2-port 100GbE module

add text

Step 3: Cable the management network connections

Cable the controllers to your management network.

1. Cable the management (wrench) ports on each controller to the management network switches.

1000BASE-T RJ-45 cables

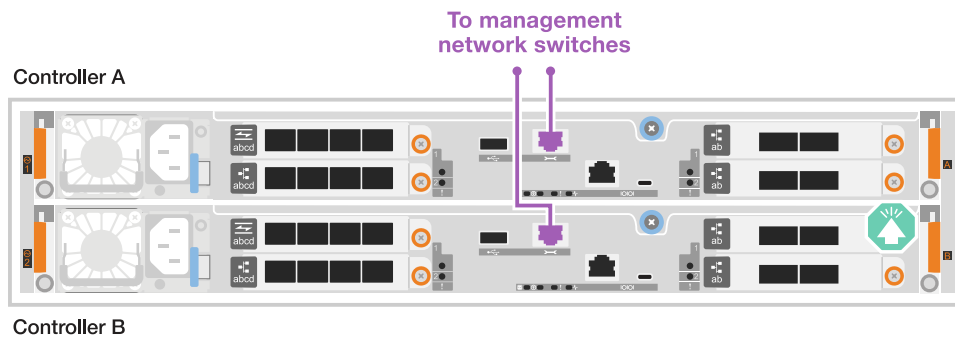

Do not plug in the power cords yet.

Step 4: Cable the shelf connections

This procedure show you how to cable the controllers to one NS224 shelf.

About this task

- For the maximum number of shelves supported for your storage system and for all of your cabling options, such as optical and switch-attached, see [NetApp Hardware Universe](#).
- You cable each controller to each NSM100B module on the NS224 shelf using the storage cables that came with your storage system, which could be the following cable type:

100 GbE QSFP28 copper cables



- The graphics show controller A cabling in blue and controller B cabling in yellow.

Steps

1. Cable controller A to the shelf:
 - a. Cable controller A port e3a to NSM A port e1a.
 - b. Cable controller A port e3b to NSM B port e1b.

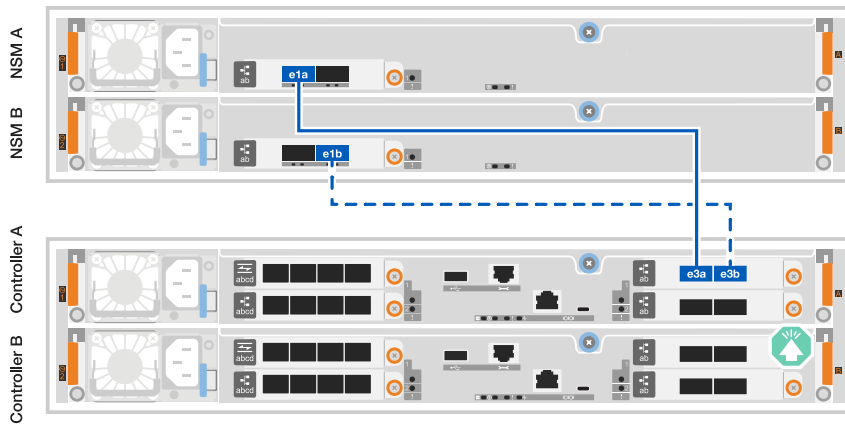

2. Cable controller B to the shelf:

- a. Cable controller B port e3a to NSM B port e1a.
- b. Cable controller B port e3b to NSM A port e1b.

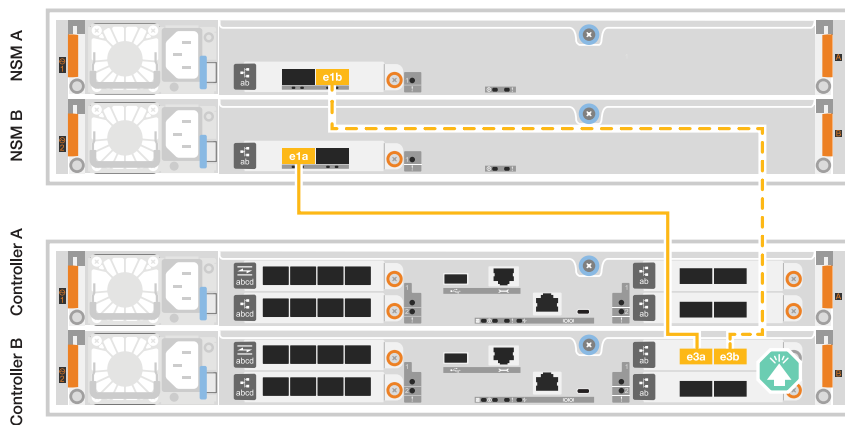

What's next?

After you've cabled the hardware for your storage system, you [power on the storage system](#).

Power on the storage system - AFF C30 and AFF C60

After you cable the controllers to the network and shelves in your AFF C30 or AFF C60 storage system, you power on your shelves and controllers.

Step 1: Power on the shelf and assign shelf ID

Each shelf is distinguished by a unique shelf ID. This ID ensures that the shelf is distinct within your storage system setup.

About this task

- A valid shelf ID is 01 through 99.

If you have internal shelves (storage), which are integrated within the controllers, they are assigned a fixed shelf ID of 00.

- You must power cycle a shelf (unplug both power cords, wait the appropriate amount of time, and then plug them back in) for the shelf ID to take effect.

Steps

1. Power on the shelf by connecting the power cords first to the shelf, securing them in place with the power cord retainer, and then connecting the power cords to power sources on different circuits.

The shelf powers on and boots automatically when plugged into the power source.

2. Remove the left end cap to access the shelf ID button behind the faceplate.

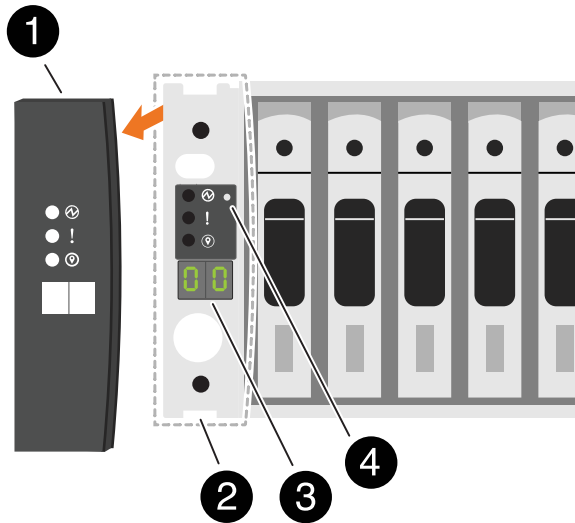

1	Shelf end cap
2	Shelf faceplate
3	Shelf ID number
4	Shelf ID button

3. Change the first number of the shelf ID:
 - a. Insert the straightened end of a paperclip or narrow tipped ball point pen into the small hole to press the shelf ID button.
 - b. Press and hold the shelf ID button until the first number on the digital display blinks, and then release the button.

It can take up to 15 seconds for the number to blink. This activates the shelf ID programming mode.



If the ID takes longer than 15 seconds to blink, press and hold the shelf ID button again, making sure to press it in all the way.

- c. Press and release the shelf ID button to advance the number until you reach the desired number from 0 to 9.

Each press and release duration can be as short as one second.

The first number continues to blink.

4. Change the second number of the shelf ID:

- a. Press and hold the button until the second number on the digital display blinks.

It can take up to three seconds for the number to blink.

The first number on the digital display stops blinking.

- b. Press and release the shelf ID button to advance the number until you reach the desired number from 0 to 9.

The second number continues to blink.

5. Lock in the desired number and exit the programming mode by pressing and holding the shelf ID button until the second number stops blinking.

It can take up to three seconds for the number to stop blinking.

Both numbers on the digital display start blinking and the amber LED illuminates after about five seconds, alerting you that the pending shelf ID has not yet taken effect.

6. Power-cycle the shelf for at least 10 seconds to make the shelf ID take effect.

- a. Unplug the power cord from both power supplies on the shelf.
- b. Wait 10 seconds.
- c. Plug the power cords back into the shelf power supplies to complete the power cycle.

A power supply is powered on as soon as the power cord is plugged in. Its bicolored LED should illuminate green.

7. Replace the left end cap.

Step 2: Power on the controllers

After you've powered on your shelves and assigned them unique IDs, power on the storage controllers.

Steps

1. Connect your laptop to the serial console port. This will allow you to monitor the boot sequence when the controllers are powered on.
 - a. Set the serial console port on the laptop to 115,200 baud with N-8-1.



See your laptop's online help for instructions on how to configure the serial console port.

- b. Using the console cable provided with your storage system, connect one end of the console cable to your laptop and the other end to the serial console port on controller A.
- c. Connect the laptop to the switch on the management subnet.

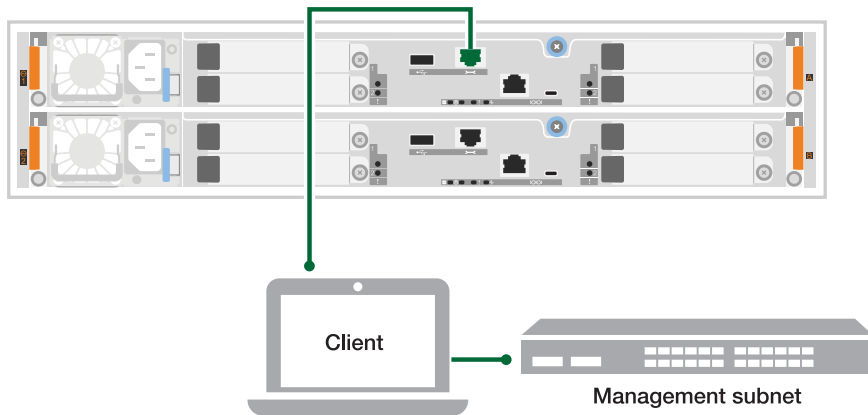

2. Assign a TCP/IP address to the laptop, using one that is on the management subnet.
3. Plug the power cords into the controller power supplies, and then connect them to power sources on different circuits.

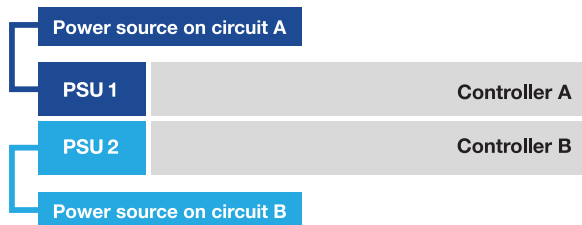

- The system begins to boot. Initial booting may take up to eight minutes.
 - The LEDs flash on and the fans start, which indicates that the controllers are powering on.
 - The fans might be very noisy when they first start up. The fan noise during start-up is normal.
4. Secure the power cords using the securing device on each power supply.

What's next?

After you've powered on your storage system, you [complete system setup](#).

Complete storage system setup and configuration - AFF C30 and AFF C60

After you've turned on your storage system, you are ready to discover your cluster network and set up an ONTAP cluster.

Step 1: Gather cluster information

If you have not already done so, gather the information you will need to configure your cluster, such as your cluster management interface port and IP address.

Use the [cluster setup worksheet](#) to record the values that you need during the cluster setup process. If a default value is provided, you can use that value or else enter your own.

Step 2: Discover your cluster network

The discovery process enables you to discover your storage system controllers on the network.

Option 1: Network discovery is enabled

If you have network discovery enabled on your laptop, you can complete setup and configuration using automatic cluster discovery.

Steps

1. Connect your laptop to the management switch and access the network computers and devices.
2. Select an ONTAP icon listed to discover:

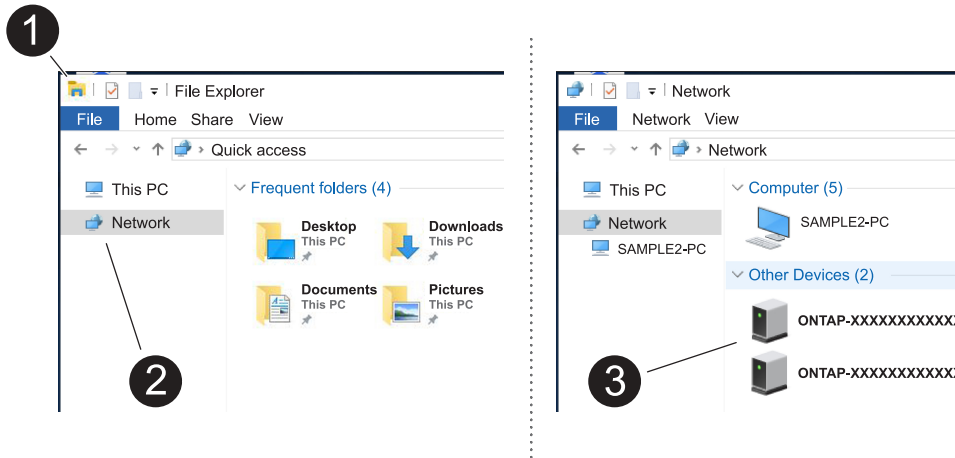

- a. Open File Explorer.
- b. Click **Network** in the left pane and right-click and select **refresh**.
- c. Double-click either ONTAP icon and accept any certificates displayed on your screen.



XXXXX is the storage system serial number for the target node.

System Manager opens.

Option 2: Network discovery is not enabled

If network discovery is not enabled on your laptop, complete the configuration and setup using the ONTAP command line interface (CLI) Cluster Setup wizard.

Before you begin

Make sure your laptop is connected to the serial console port and the controllers are powered on. See [power on the storage system](#) for instructions.

Steps

Assign an initial node management IP address to one of the nodes.

If the management network has DHCP...	Then...
Configured	Record the IP address assigned to the new controllers.

If the management network has DHCP...	Then...
Not configured	<p>a. Open a console session using PuTTY, a terminal server, or the equivalent for your environment.</p> <div style="display: flex; align-items: center; margin: 10px 0;">  <p>Check your laptop or console's online help if you do not know how to configure PuTTY.</p> </div> <p>b. Connect to the console of the first node.</p> <p>The node boots, and then the Cluster Setup wizard starts on the console.</p> <p>c. Enter the node's management IP address when prompted by the Cluster Setup wizard.</p>

Step 3: Configure your cluster

NetApp recommends that you use System Manager to set up new clusters. See [Configure ONTAP on a new cluster with System Manager](#) for setup instructions.

System Manager provides a simple and easy workflow for cluster set up and configuration including assigning a node management IP address, initializing the cluster, creating a local tier, configuring protocols and initial provisioning of attached storage.

What's next?

After your cluster is initialized, download and run [Active IQ Config Advisor](#) to confirm your setup.

Copyright information

Copyright © 2024 NetApp, Inc. All Rights Reserved. Printed in the U.S. No part of this document covered by copyright may be reproduced in any form or by any means—graphic, electronic, or mechanical, including photocopying, recording, taping, or storage in an electronic retrieval system—without prior written permission of the copyright owner.

Software derived from copyrighted NetApp material is subject to the following license and disclaimer:

THIS SOFTWARE IS PROVIDED BY NETAPP “AS IS” AND WITHOUT ANY EXPRESS OR IMPLIED WARRANTIES, INCLUDING, BUT NOT LIMITED TO, THE IMPLIED WARRANTIES OF MERCHANTABILITY AND FITNESS FOR A PARTICULAR PURPOSE, WHICH ARE HEREBY DISCLAIMED. IN NO EVENT SHALL NETAPP BE LIABLE FOR ANY DIRECT, INDIRECT, INCIDENTAL, SPECIAL, EXEMPLARY, OR CONSEQUENTIAL DAMAGES (INCLUDING, BUT NOT LIMITED TO, PROCUREMENT OF SUBSTITUTE GOODS OR SERVICES; LOSS OF USE, DATA, OR PROFITS; OR BUSINESS INTERRUPTION) HOWEVER CAUSED AND ON ANY THEORY OF LIABILITY, WHETHER IN CONTRACT, STRICT LIABILITY, OR TORT (INCLUDING NEGLIGENCE OR OTHERWISE) ARISING IN ANY WAY OUT OF THE USE OF THIS SOFTWARE, EVEN IF ADVISED OF THE POSSIBILITY OF SUCH DAMAGE.

NetApp reserves the right to change any products described herein at any time, and without notice. NetApp assumes no responsibility or liability arising from the use of products described herein, except as expressly agreed to in writing by NetApp. The use or purchase of this product does not convey a license under any patent rights, trademark rights, or any other intellectual property rights of NetApp.

The product described in this manual may be protected by one or more U.S. patents, foreign patents, or pending applications.

LIMITED RIGHTS LEGEND: Use, duplication, or disclosure by the government is subject to restrictions as set forth in subparagraph (b)(3) of the Rights in Technical Data -Noncommercial Items at DFARS 252.227-7013 (FEB 2014) and FAR 52.227-19 (DEC 2007).

Data contained herein pertains to a commercial product and/or commercial service (as defined in FAR 2.101) and is proprietary to NetApp, Inc. All NetApp technical data and computer software provided under this Agreement is commercial in nature and developed solely at private expense. The U.S. Government has a non-exclusive, non-transferrable, nonsublicensable, worldwide, limited irrevocable license to use the Data only in connection with and in support of the U.S. Government contract under which the Data was delivered. Except as provided herein, the Data may not be used, disclosed, reproduced, modified, performed, or displayed without the prior written approval of NetApp, Inc. United States Government license rights for the Department of Defense are limited to those rights identified in DFARS clause 252.227-7015(b) (FEB 2014).

Trademark information

NETAPP, the NETAPP logo, and the marks listed at <http://www.netapp.com/TM> are trademarks of NetApp, Inc. Other company and product names may be trademarks of their respective owners.