



# Controller

## Install and maintain

NetApp  
September 25, 2024

# Table of Contents

- Controller ..... 1
  - Controller replacement workflow - ASA A70 and ASA A90 ..... 1
  - Controller replace requirements - ASA A70 and ASA A90 ..... 1
  - Shut down the impaired controller - ASA A70 and ASA A90 ..... 2
  - Replace the controller module hardware - ASA A70 and ASA A90 ..... 3
  - Restore and verify the system configuration - ASA A70 and ASA A90 ..... 12
  - Recable and give back the controller - ASA A70 and ASA A90 ..... 13
  - Complete system restoration - ASA A70 and ASA A90 ..... 15

# Controller

## Controller replacement workflow - ASA A70 and ASA A90

Follow these workflow steps to replace your controller module.

1

### Review controller replacement requirements

To replace the controller module, you must meet certain requirements.

2

### Shut down the impaired controller

Shut down or take over the impaired controller so that the healthy controller continues to serve data from the impaired controller storage.

3

### Replace the controller

Replacing the controller includes removing the impaired controller, moving the FRU components to the replacement controller module, and then installing the replacement controller module in the enclosure.

4

### Restore and verify the system configuration

Verify the low-level system configuration of the replacement controller and reconfigure system settings as necessary.

5

### Recable and give back the controller

Recable the controller and transfer the ownership of storage resources back to the replacement controller.

6

### Complete controller replacement

Verify the Lifs, check cluster health, and return the failed part to NetApp.

## Controller replace requirements - ASA A70 and ASA A90

You must review the requirements for the controller replacement procedure and select the correct one for your version of the ONTAP operating system.

- All drive shelves must be working properly.
- The healthy controller must be able to take over the controller that is being replaced (referred to in this procedure as the “impaired controller”).
- You must replace the failed component with a replacement FRU component you received from your provider.
- You must replace a controller module with a controller module of the same model type. You cannot upgrade your system by just replacing the controller module.

- You cannot change any drives or drive shelves as part of this procedure.
- Because the boot device is located on the System Management module that is installed in the back of the system, you do not need to move the boot device when replacing a controller module.
- It is important that you apply the commands in these steps on the correct systems:
  - The *impaired* controller is the controller that is being replaced.
  - The *replacement* controller is the new controller that is replacing the impaired controller.
  - The *healthy* controller is the surviving controller.
- You must always capture the controller's console output to a text log file.

This provides you a record of the procedure so that you can troubleshoot any issues that you might encounter during the replacement process.

## Shut down the impaired controller - ASA A70 and ASA A90

Shut down or take over the impaired controller.

To shut down the impaired controller, you must determine the status of the controller and, if necessary, take over the controller so that the healthy controller continues to serve data from the impaired controller storage.

### About this task

- If you have a SAN system, you must have checked event messages (`cluster kernel-service show`) for the impaired controller SCSI blade. The `cluster kernel-service show` command (from `priv advanced mode`) displays the node name, quorum status of that node, availability status of that node, and operational status of that node.

Each SCSI-blade process should be in quorum with the other nodes in the cluster. Any issues must be resolved before you proceed with the replacement.

- If you have a cluster with more than two nodes, it must be in quorum. If the cluster is not in quorum or a healthy controller shows `false` for eligibility and health, you must correct the issue before shutting down the impaired controller; see [Synchronize a node with the cluster](#).

### Steps

1. If AutoSupport is enabled, suppress automatic case creation by invoking an AutoSupport message:
 

```
system node autosupport invoke -node * -type all -message MAINT=<# of hours>h
```

The following AutoSupport message suppresses automatic case creation for two hours: `cluster1:>`

```
system node autosupport invoke -node * -type all -message MAINT=2h
```

2. Disable automatic giveback from the console of the healthy controller: `storage failover modify -node local -auto-giveback false`



When you see *Do you want to disable auto-giveback?*, enter `y`.

3. Take the impaired controller to the LOADER prompt:

If the impaired controller is displaying...	Then...
The LOADER prompt	Go to the next step.
Waiting for giveback...	Press Ctrl-C, and then respond <code>y</code> when prompted.
System prompt or password prompt	Take over or halt the impaired controller from the healthy controller: <pre>storage failover takeover -ofnode impaired_node_name</pre> When the impaired controller shows Waiting for giveback..., press Ctrl-C, and then respond <code>y</code> .

## Replace the controller module hardware - ASA A70 and ASA A90

To replace the controller, you must remove the impaired controller, move FRU components from the impaired controller module to the replacement controller module, install the replacement controller module in the chassis, and then boot the system to Maintenance mode.

### Step 1: Remove the controller module

You must remove the controller module from the chassis when you replace the controller module or replace a component inside the controller module.

1. On the front of the chassis, use your thumbs to firmly push each drive in until you feel a positive stop. This ensures that the drives are firmly seated against the chassis midplane.

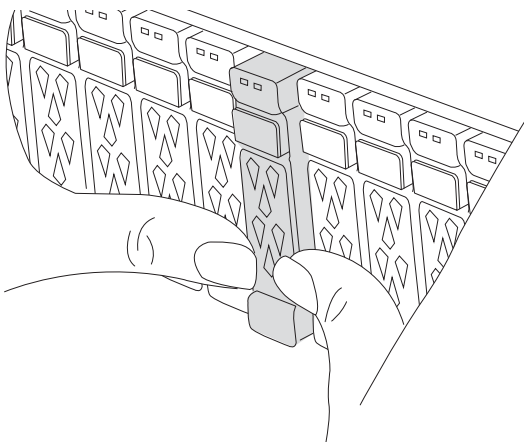

2. Check the amber NVRAM that status LED located in slot 4/5 on the back of the impaired controller module is off. Look for the NV icon.

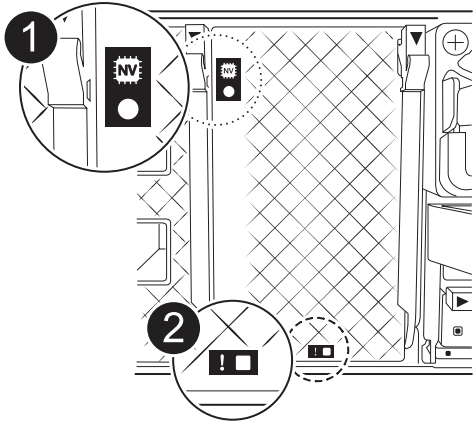

<b>1</b>	NVRAM status LED
<b>2</b>	NVRAM attention LED



If the NVRAM status LED is flashing, it could mean the controller module was not taken over or halted properly (uncommitted data). If the impaired controller module was not successfully taken over by the partner controller module, contact [NetApp Support](#) before continuing with this procedure.

The general behavior of the NVRAM status LED on the impaired controller module is as follows:

- The NVRAM status LED flashes when power is removed from the controller module and the storage system is in the "waiting for giveback" state, or the controller module is not taken over or halted properly (uncommitted data).
- The NVRAM status LED flashes when the controller module is removed from the chassis and could mean the controller module is not taken over or halted properly (uncommitted data). Confirm that the controller module has been cleanly takeover by the partner controller module or the impaired controller module shows `waiting for giveback`. Then, the flashing LED can be ignored (and the controller module can be removed from the chassis).

3. If you are not already grounded, properly ground yourself.
4. Unplug the controller module power supply cables from the controller module power supplies (PSU).



If your system has DC power, disconnect the power block from the PSUs.

5. Unplug the system cables and SFP and QSFP modules (if needed) from the controller module, keeping track of where the cables were connected.

Leave the cables in the cable management device so that when you reinstall the cable management device, the cables are organized.

6. Remove the cable management device from the controller module.
7. Press down on both of the locking latches, and then rotate both latches downward at the same time.

The controller module moves slightly out of the chassis.

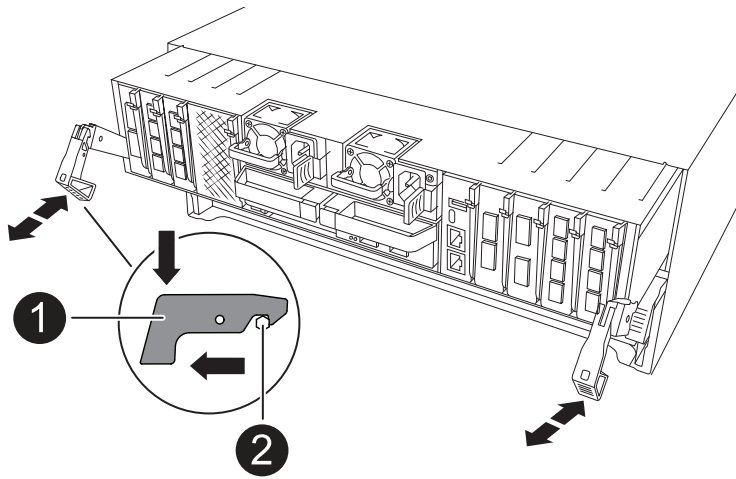

1	a Locking latch
2	Locking pin

8. Slide the controller module out of the chassis and place it on a flat, stable surface.

Make sure that you support the bottom of the controller module as you slide it out of the chassis.

## Step 2: Move the power supplies

Move the power supplies to the replacement controller.

1. Rotate the cam handle such that it can be used to pull power supply out of the controller module while pressing the locking tab.



The power supply is short. Always use two hands to support it when removing it from the controller module so that it does not suddenly swing free from the controller module and injure you.

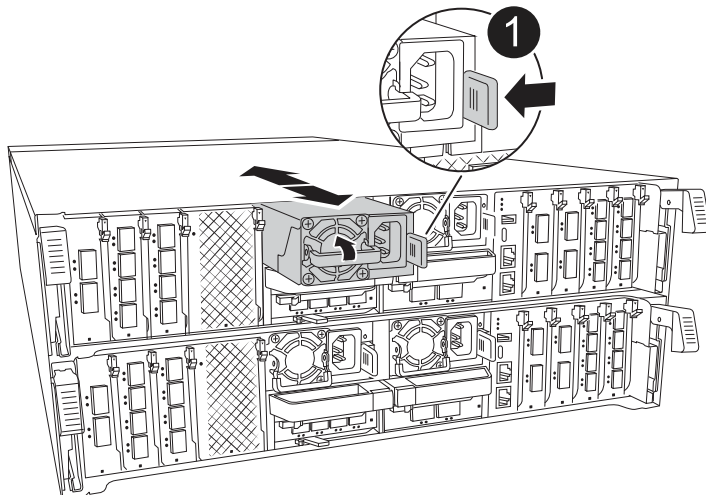

1	Terracotta PSU locking tab
2	Power supply

2. Move the power supply to the new controller module, and then install it.
3. Using both hands, support and align the edges of the power supply with the opening in the controller module, and then gently push the power supply into the controller module until the locking tab clicks into place.

The power supplies will only properly engage with the internal connector and lock in place one way.



To avoid damaging the internal connector, do not use excessive force when sliding the power supply into the system.

### Step 3: Move the fans

Move the fans modules to the replacement controller module.

1. Remove the fan module by pinching the locking tabs on the side of the fan module, and then lifting the fan module straight out of the controller module.

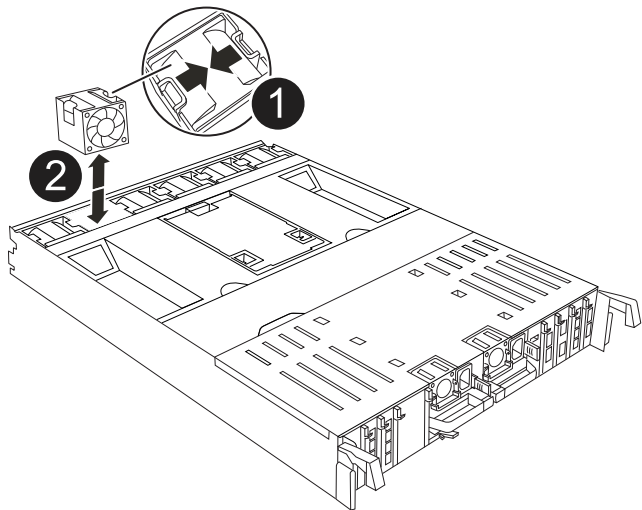

1	Fan locking tabs
2	Fan module

2. Move the fan module to the replacement controller module, and then install the fan module by aligning its edges with the opening in the controller module, and then sliding the fan module into the controller module until the locking latches click into place.
3. Repeat these steps for the remaining fan modules.



## Step 4: Move the NV battery

Move the NV battery to the replacement controller module.

1. Open the air duct cover in the middle of the controller module and locate the NV battery.

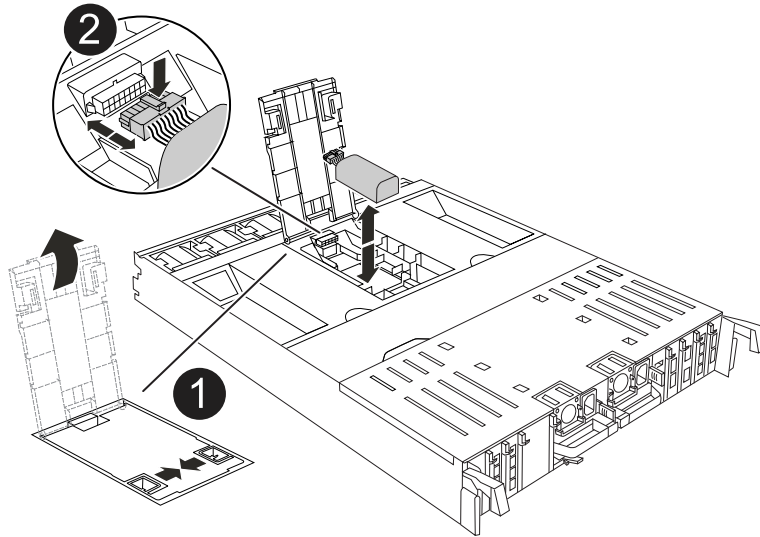

<b>1</b>	NV battery air duct
<b>2</b>	NV battery pack plug

**Attention:** The NV module LED blinks while destaging contents to the flash memory when you halt the system. After the destage is complete, the LED turns off.

2. Lift the battery up to access the battery plug.
3. Squeeze the clip on the face of the battery plug to release the plug from the socket, and then unplug the battery cable from the socket.
4. Lift the battery out of the air duct and controller module.
5. Move the battery pack to the replacement controller module and then install it in the replacement controller module:
  - a. Open the NV battery air duct in the replacement controller module.
  - b. Plug the battery plug into the socket and make sure that the plug locks into place.
  - c. Insert the battery pack into the slot and press firmly down on the battery pack to make sure that it is locked into place.
  - d. Close the NV battery air duct.

## Step 5: Move system DIMMs

Move the DIMMs to the replacement controller module.

1. Open the controller air duct on the top of the controller.
  - a. Insert your fingers in the recesses at the far ends of the air duct.

b. Lift the air duct and rotate it upward as far as it will go.

2. Locate the system DIMMs on the motherboard.

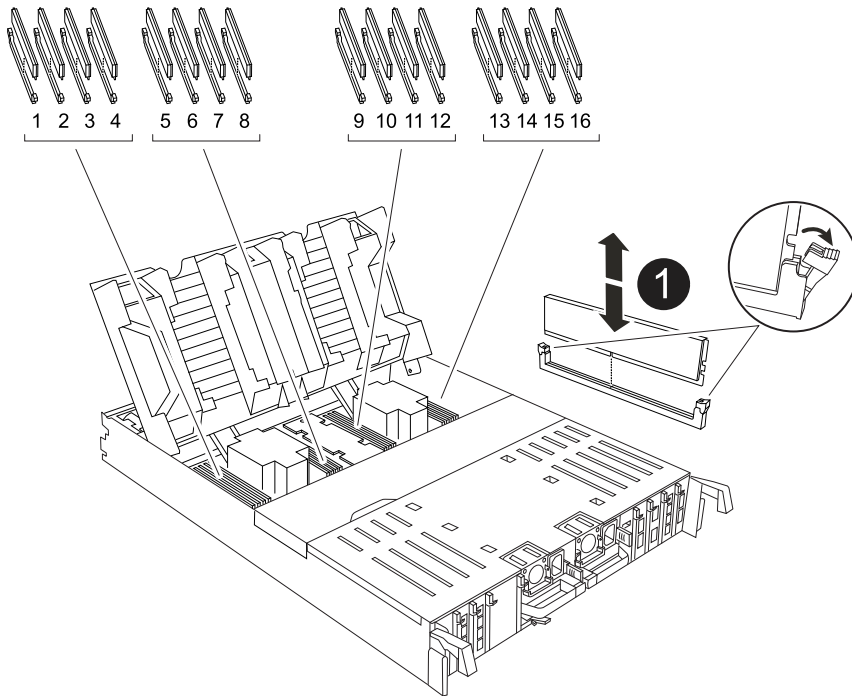

<b>1</b>	System DIMM
----------	-------------

3. Note the orientation of the DIMM in the socket so that you can insert the DIMM in the replacement controller module in the proper orientation.

4. Eject the DIMM from its slot by slowly pushing apart the two DIMM ejector tabs on either side of the DIMM, and then slide the DIMM out of the slot.



Carefully hold the DIMM by the edges to avoid pressure on the components on the DIMM circuit board.

5. Locate the slot on the replacement controller module where you are installing the DIMM.

6. Insert the DIMM squarely into the slot.

The DIMM fits tightly in the slot, but should go in easily. If not, realign the DIMM with the slot and reinsert it.



Visually inspect the DIMM to verify that it is evenly aligned and fully inserted into the slot.

7. Push carefully, but firmly, on the top edge of the DIMM until the ejector tabs snap into place over the notches at the ends of the DIMM.

8. Repeat these steps for the remaining DIMMs.

9. Close the controller air duct.

## Step 6: Move the I/O modules

Move the I/O modules to the replacement controller module.

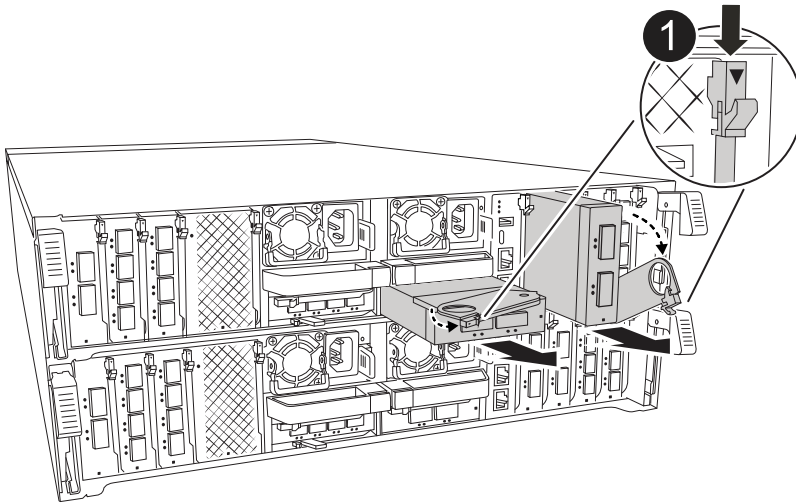

**1** I/O module cam lever

1. Unplug any cabling on the target I/O module.

Make sure that you label the cables so that you know where they came from.

2. Rotate the cable management arm down by pulling the buttons on the inside of the cable management arm and rotating it down.
3. Remove the I/O modules from the controller module:
  - a. Depress the target I/O module cam latch button.
  - b. Rotate the cam latch down as far as it will go. For horizontal modules, rotate the cam away from the module as far as it will go.
  - c. Remove the module from the controller module by hooking your finger into the cam lever opening and pulling the module out of the controller module.

Make sure that you keep track of which slot the I/O module was in.

- d. Install the replacement I/O module into the replacement controller module by gently sliding the I/O module into the slot until the I/O cam latch begins to engage with the I/O cam pin, and then push the I/O cam latch all the way up to lock the module in place.
4. Repeat these steps to move the remaining I/O modules, except the modules in slots 6 and 7, to the replacement controller module.



To move the I/O modules from slots 6 and 7, you must move the carrier containing these I/O modules from the impaired controller module to the replacement controller module.

5. Move the carrier containing the I/O modules in slots 6 and 7 to the replacement controller module:
  - a. Press the button on the right-most handle on the carrier handle. ..Slide the carrier out of the impaired controller module insert it into the replacement controller module in the same position it was in the impaired controller module.

- b. Gently push the carrier all the way into the replacement controller module until it locks into place.

## Step 7: Move the System Management module

Move the System Management module to the replacement controller module.

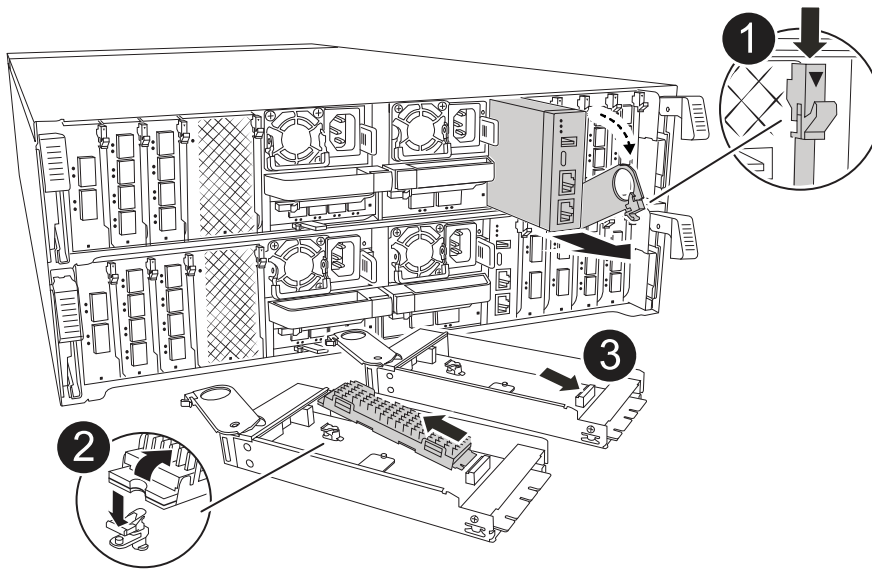

<b>1</b>	System Management module cam latch
<b>2</b>	Boot media locking button
<b>3</b>	Replacement System Management module

1. Remove the System Management module from the impaired controller module:
  - a. Depress the system management cam button.
  - b. Rotate the cam lever all the way down.
  - c. Loop your finger into the cam lever and pull the module straight out of the system.
2. Install the system management module into the replacement controller module in the same slot that it was in on the impaired controller module:
  - a. Align the edges of the System Management module with the system opening and gently push it into the controller module.
  - b. Gently slide the module into the slot until the cam latch begins to engage with the I/O cam pin, and then rotate the cam latch all the way up to lock the module in place.

## Step 8: Move the NVRAM module

Move the NVRAM module to the replacement controller module.

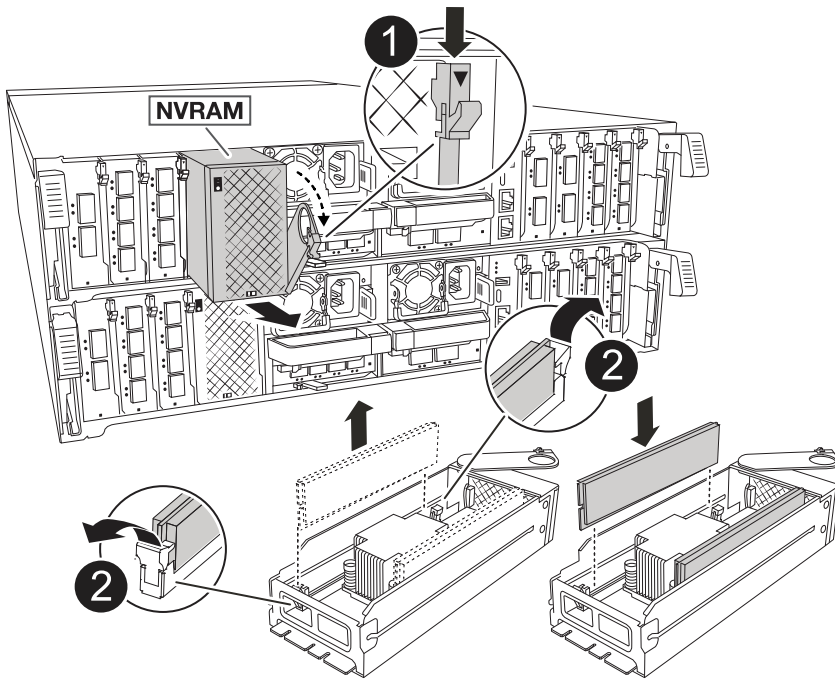

1	Cam locking button
2	DIMM locking tab

1. Remove the NVRAM module from the impaired controller module:

- a. Depress the cam latch button.

The cam button moves away from the chassis.

- b. Rotate the cam latch as far as it will go.

- c. Remove the NVRAM module from the enclosure by hooking your finger into the cam lever opening and pulling the module out of the enclosure.

2. Install the NVRAM module into slot 4/5 in the replacement controller module:

- a. Align the module with the edges of the chassis opening in slot 4/5.

- b. Gently slide the module into the slot all the way, and then push the cam latch all the way up to lock the module in place.

## Step 9: Install the controller module

Reinstall the controller module and reboot it.

- 1. Ensure the air duct is completely closed by rotating it down as far as it will go.

It must lie flush against the controller module sheet metal.

- 2. Align the end of the controller module with the opening in the chassis, and then gently push the controller module halfway into the system.



Do not completely insert the controller module in the chassis until instructed to do so.

3. Recable the system, as needed.

If you removed the transceivers (QSFPs or SFPs), remember to reinstall them if you are using fiber optic cables.

4. Complete the reinstallation of the controller module:

- a. Firmly push the controller module into the chassis until it meets the midplane and is fully seated.

The locking latches rise when the controller module is fully seated.



Do not use excessive force when sliding the controller module into the chassis to avoid damaging the connectors.

- a. Rotate the locking latches upward into the locked position.

5. Plug the power cords into the power supplies.



If you have DC power supplies, reconnect the power block to the power supplies after the controller module is fully seated in the chassis.

The controller module boots when power is restored. If it boots to the LOADER prompt, reboot the controller with the `boot_ontap` command.

6. Restore automatic giveback if you disabled it by using the `storage failover modify -node local -auto-giveback true` command.
7. If AutoSupport is enabled, restore/unsuppress automatic case creation by using the `system node autosupport invoke -node * -type all -message MAINT=END` command.
8. If you have not already done so, reinstall the cable management device and recable the controller.

## Restore and verify the system configuration - ASA A70 and ASA A90

Verify the low-level system configuration of the replacement controller and reconfigure the system settings as necessary.

### Step 1: Set and verify system time

You should check the time and date on the replacement controller module against the healthy controller module in an HA pair, or against a reliable time server in a stand-alone configuration. If the time and date do not match, you must reset them on the replacement controller module to prevent possible outages on clients due to time differences.

#### About this task

It is important that you apply the commands in the steps on the correct systems:

- The *replacement* node is the new node that replaced the impaired node as part of this procedure.
- The *healthy* node is the HA partner of the *replacement* node.

## Steps

1. If the *replacement* node is not at the LOADER prompt, halt the system to the LOADER prompt.
2. On the *healthy* node, check the system time: `cluster date show`

The date and time are based on the configured timezone.

3. At the LOADER prompt, check the date and time on the *replacement* node: `show date`

The date and time are given in GMT.

4. If necessary, set the date in GMT on the replacement node: `set date mm/dd/yyyy`
5. If necessary, set the time in GMT on the replacement node: `set time hh:mm:ss`
6. At the LOADER prompt, confirm the date and time on the *replacement* node: `show date`

The date and time are given in GMT.

## Step 2: Verify and set the HA state of the chassis

You must verify the HA state of the controller module and, if necessary, update the state to match your system configuration.

1. In Maintenance mode from the new controller module, verify that all components display the same HA state: `ha-config show`

The HA state should be the same for all components.

2. If the displayed system state of the controller module does not match your system configuration, set the HA state for the controller module: `ha-config modify controller ha-state`

The value for HA-state can be one of the following:

- `ha`
- `mcc` (not supported)
- `mccip` (not supported in ASA systems)
- `non-ha` (not supported)

3. If the displayed system state of the controller module does not match your system configuration, set the HA state for the controller module: `ha-config modify controller ha-state`
4. Confirm that the setting has changed: `ha-config show`

## Recable and give back the controller - ASA A70 and ASA A90

Recable the storage and network connections, and then give back the controller.

## Step 1: Recable the controller

Recable the controller module's storage and network connections.

### Steps

1. Recable the the controller module to storage and network connections.
2. Verify that the cabling is correct by using [Active IQ Config Advisor](#).
  - a. Download and install Config Advisor.
  - b. Enter the information for the target system, and then click Collect Data.
  - c. Click the Cabling tab, and then examine the output. Make sure that all disk shelves are displayed and all disks appear in the output, correcting any cabling issues you find.
  - d. Check other cabling by clicking the appropriate tab, and then examining the output from Config Advisor.

## Step 2: Give back the controller

Transfer the ownership of storage resources back to the replacement controller.

1. If your storage system has Encryption configured, you must restore Storage or Volume Encryption functionality using the following procedure to reboot the system:
  - a. Boot to Menu and run Option 10
  - b. Input the passphrase & backup up data, then do Normal boot see [Restore onboard key management encryption keys](#).
  - c. Perform CFO only giveback
  - d. Perform Onboard Sync and verify SVM-KEK is set to true see [Giveback after MB replacement fails - operation was vetoed by keymanager](#)
  - e. Giveback SFO, (no force)
2. If your system does not have Encryption configured, complete the following procedure to reboot the system:
  - a. Boot to Menu and run Option 1.
  - b. Give back the controller:
  - c. From the healthy controller, give back the replaced controller's storage: `storage failover giveback -ofnode replacement_node_name`

The *replacement* controller takes back its storage and completes booting.



If the giveback is vetoed, you can consider overriding the vetoes.

[Find the High-Availability Configuration content for your version of ONTAP 9](#)

- d. After the giveback has been completed, confirm that the HA pair is healthy and that takeover is possible: `storage failover show`
3. Verify that the expected volumes are present for each controller: `vol show -node node-name`
  4. If you disabled automatic takeover on reboot, enable it from the healthy controller: `storage failover modify -node replacement-node-name -onreboot true`



# Complete system restoration - ASA A70 and ASA A90

To restore your system to full operation, you must verify the LIFs, check cluster health, and return the failed part to NetApp.

## Step 1: Verify LIFs and check cluster health

Before returning the *replacement* node to service, you should verify that the LIFs are on their home ports, check the cluster health, and reset automatic giveback.

### Steps

1. Verify that the logical interfaces are reporting to their home server and ports: `network interface show -is-home false`

If any LIFs are listed as false, revert them to their home ports: `network interface revert -vserver * -lif *`

2. Check the health of your cluster. See the [How to perform a cluster health check with a script in ONTAP KB](#) article for more information.
3. If automatic giveback was disabled, reenable it: `storage failover modify -node local -auto-giveback true`

## Step 2: Return the failed part to NetApp

Return the failed part to NetApp, as described in the RMA instructions shipped with the kit. See the [Part Return and Replacements](#) page for further information.

## Copyright information

Copyright © 2024 NetApp, Inc. All Rights Reserved. Printed in the U.S. No part of this document covered by copyright may be reproduced in any form or by any means—graphic, electronic, or mechanical, including photocopying, recording, taping, or storage in an electronic retrieval system—without prior written permission of the copyright owner.

Software derived from copyrighted NetApp material is subject to the following license and disclaimer:

THIS SOFTWARE IS PROVIDED BY NETAPP "AS IS" AND WITHOUT ANY EXPRESS OR IMPLIED WARRANTIES, INCLUDING, BUT NOT LIMITED TO, THE IMPLIED WARRANTIES OF MERCHANTABILITY AND FITNESS FOR A PARTICULAR PURPOSE, WHICH ARE HEREBY DISCLAIMED. IN NO EVENT SHALL NETAPP BE LIABLE FOR ANY DIRECT, INDIRECT, INCIDENTAL, SPECIAL, EXEMPLARY, OR CONSEQUENTIAL DAMAGES (INCLUDING, BUT NOT LIMITED TO, PROCUREMENT OF SUBSTITUTE GOODS OR SERVICES; LOSS OF USE, DATA, OR PROFITS; OR BUSINESS INTERRUPTION) HOWEVER CAUSED AND ON ANY THEORY OF LIABILITY, WHETHER IN CONTRACT, STRICT LIABILITY, OR TORT (INCLUDING NEGLIGENCE OR OTHERWISE) ARISING IN ANY WAY OUT OF THE USE OF THIS SOFTWARE, EVEN IF ADVISED OF THE POSSIBILITY OF SUCH DAMAGE.

NetApp reserves the right to change any products described herein at any time, and without notice. NetApp assumes no responsibility or liability arising from the use of products described herein, except as expressly agreed to in writing by NetApp. The use or purchase of this product does not convey a license under any patent rights, trademark rights, or any other intellectual property rights of NetApp.

The product described in this manual may be protected by one or more U.S. patents, foreign patents, or pending applications.

LIMITED RIGHTS LEGEND: Use, duplication, or disclosure by the government is subject to restrictions as set forth in subparagraph (b)(3) of the Rights in Technical Data -Noncommercial Items at DFARS 252.227-7013 (FEB 2014) and FAR 52.227-19 (DEC 2007).

Data contained herein pertains to a commercial product and/or commercial service (as defined in FAR 2.101) and is proprietary to NetApp, Inc. All NetApp technical data and computer software provided under this Agreement is commercial in nature and developed solely at private expense. The U.S. Government has a non-exclusive, non-transferrable, nonsublicensable, worldwide, limited irrevocable license to use the Data only in connection with and in support of the U.S. Government contract under which the Data was delivered. Except as provided herein, the Data may not be used, disclosed, reproduced, modified, performed, or displayed without the prior written approval of NetApp, Inc. United States Government license rights for the Department of Defense are limited to those rights identified in DFARS clause 252.227-7015(b) (FEB 2014).

## Trademark information

NETAPP, the NETAPP logo, and the marks listed at <http://www.netapp.com/TM> are trademarks of NetApp, Inc. Other company and product names may be trademarks of their respective owners.