



# **ASA systems**

## **Install and maintain**

NetApp  
September 25, 2024

# Table of Contents

- ASA systems ..... 1
  - All-Flash SAN Array (ASA) A-Series Systems ..... 1
  - All-Flash SAN Array (ASA) C-Series Systems ..... 516

# ASA systems

## All-Flash SAN Array (ASA) A-Series Systems

### ASA A150 systems

#### Install and setup

**Start here:** Choose your installation and setup experience

For most configurations, you can choose from different content formats.

- [Quick steps](#)

A printable PDF of step-by-step instructions with live links to additional content.

- [Video steps](#)

Video step-by-step instructions.

- [Detailed steps](#)

Online step-by-step instructions with live links to additional content.

If your system is in a MetroCluster IP configuration, see the [Install MetroCluster IP Configuration](#) instructions.

#### Quick guide - ASA A150

The Installation and Setup instructions give graphic instructions for a typical installation of your system, from racking and cabling, through initial system bring-up. Use this guide if you are familiar with installing NetApp systems.

Use the [xref:./asa150/AFF A150 System Installation and Setup Instructions](#)



The ASA A150 uses the same installation procedure as the AFF A150 system.

#### Video steps - ASA A150

Use the following videos to learn how to rack and cable your system and perform initial system configuration.

If you have a MetroCluster configuration, use the [MetroCluster documentation](#).

#### Hardware installation and cabling

The following video shows how to install and cable your system.

[Animation - Install and setup of an AFF A150](#)



The ASA A150 uses the same installation procedure as the AFF A150 system.

Learn how to install your ASA A150 system.

If you have a MetroCluster configuration, use the [MetroCluster documentation](#).

### Step 1: Prepare for installation

To install your system, create an account on the NetApp Support Site, register your system, and obtain your license keys. You also need to inventory the appropriate number and type of cables for your system and collect specific network information.

#### Before you begin

- Make sure you have access to [NetApp Hardware Universe](#) (HWU) for information about site requirements as well as additional information on your configured system.
- Make sure you have access to the [Release Notes](#) for your version of ONTAP for more information about this system.
- Contact your network administrator for information about connecting your system to the switches.
- Make sure you have the following items at your site:
  - Rack space for the storage system
  - Phillips #2 screwdriver
  - Additional networking cables to connect your system to your network switch and laptop or console with a Web browser
  - A laptop or console with an RJ-45 connection and access to a Web browser

#### Steps







1. Unpack the contents of all boxes.
2. Record the system serial number from the controllers.



3. Set up your account:
  - a. Log in to your existing account or create an account.
  - b. [Register your system](#).
4. Download and install [Config Advisor](#) on your laptop.
5. Inventory and make a note of the number and types of cables you received.

The following table identifies the types of cables you might receive. If you receive a cable not listed in the table, see [NetApp Hardware Universe](#) to locate the cable and identify its use.

Type of cable...	Part number and length	Connector type	For...
10 GbE cable (order dependent)	X6566B-05-R6 (112-00297), 0.5m X6566B-2-R6 (112-00299), 2m		Cluster interconnect network

Type of cable...	Part number and length	Connector type	For...
10 GbE cable (order dependent)	Part number X6566B-2-R6 (112-00299), 2m or X6566B-3-R6 (112-00300), 3m X6566B-5-R6 (112-00301), 5m		Data
Optical network cables (order dependent)	X6553-R6 (112-00188), 2m X6536-R6 (112-00090), 5m X6554-R6(112-00189), 15m		FC host network
Cat 6, RJ-45 (order dependent)	Part numbers X6585-R6 (112-00291), 3m X6562-R6 (112-00196), 5m		Management network and Ethernet data
Storage (order dependent)	Part number X66030A (112-00435), 0.5m X66031A (112-00436), 1m X66032A (112-00437), 2m X66033A (112-00438), 3m		Storage
Micro-USB console cable	Not applicable		Console connection during software setup on non-Windows or Mac laptop/console
Power cables	Not applicable		Powering up the system

6. [Download and complete the Cluster Configuration Worksheet.](#)

**Step 2: Install the hardware**

Install your system in a 4-post rack or NetApp system cabinet, as applicable.

**Steps**

1. Install the rail kits, as needed.
2. Install and secure your system using the instructions included with the rail kit.



You need to be aware of the safety concerns associated with the weight of the system.

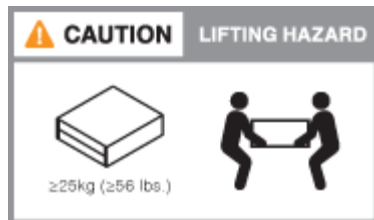

3. Attach cable management devices (as shown).

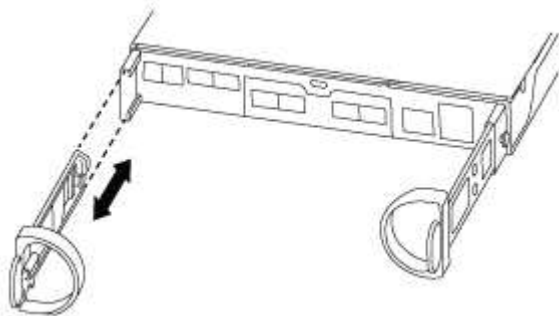

4. Place the bezel on the front of the system.

### Step 3: Cable controllers to network

Cable the controllers to your network by using either the two-node switchless cluster method or the cluster interconnect network method.

Management network, UTA2 data network, Ethernet data network, and management ports on the controllers are connected to switches. The cluster interconnect ports are cabled on both controllers.

## Option 1: Two-node switchless cluster

Learn how to cable a two-node switchless cluster.

### Before you begin

Be sure to check the illustration arrow for the proper cable connector pull-tab orientation.

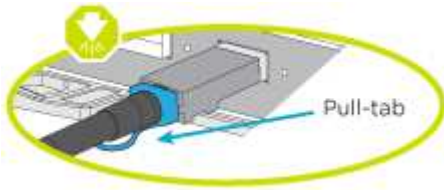

As you insert the connector, you should feel it click into place; if you do not feel it click, remove it, turn it around and try again.

### About this task

You can use either the UTA2 data network ports or the ethernet data network ports to connect the controllers to your host network. Refer to the following cabling illustrations when cabling between the controllers and the switches.

#### UTA2 data network configurations

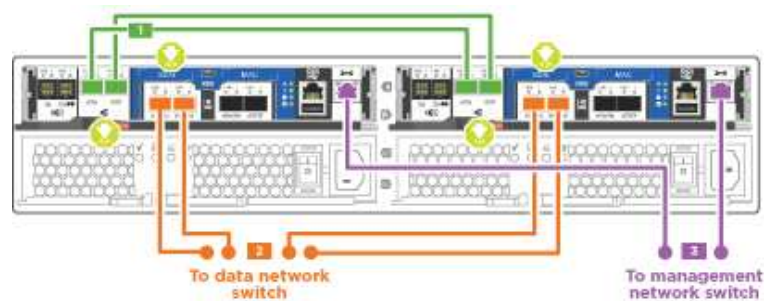

#### Ethernet network configurations

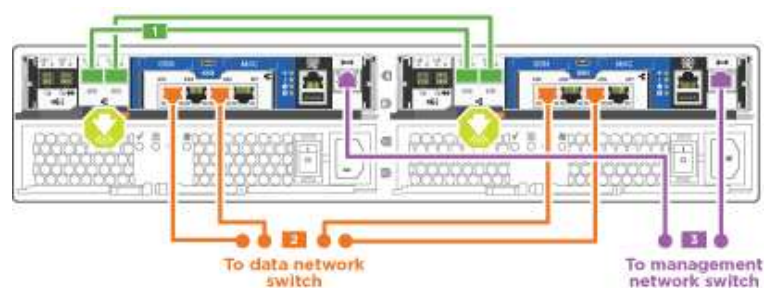

Perform the following steps on each controller module.

### Steps

1. Cable the cluster interconnect ports e0a to e0a and e0b to e0b with the cluster interconnect cable.

  
Cluster interconnect cables

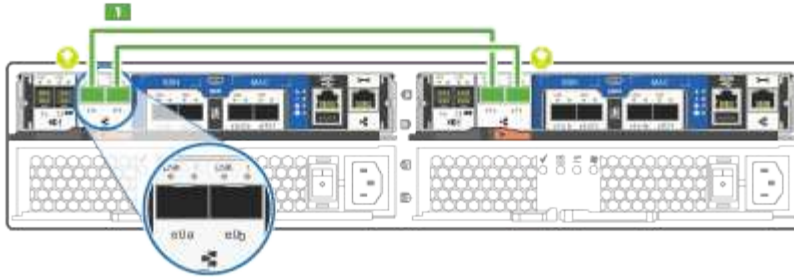

2. Do one of the following:

### UTA2 data network configurations

Use one of the following cable types to cable the UTA2 data ports to your host network.

- For an FC host, use 0c and 0d **or** 0e and 0f.
- For an 10GbE system, use e0c and e0d **or** e0e and e0f.

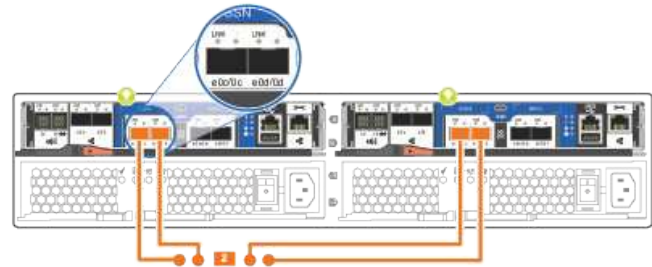
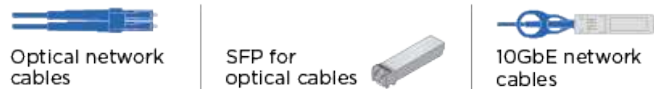

You can connect one port pair as CNA and one port pair as FC, or you can connect both port pairs as CNA or both port pairs as FC.

### Ethernet network configurations

Use the Cat 6 RJ45 cable to cable the e0c through e0f ports to your host network. in the following illustration.

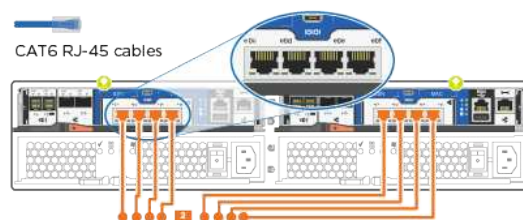



3. Cable the e0M ports to the management network switches with the RJ45 cables.

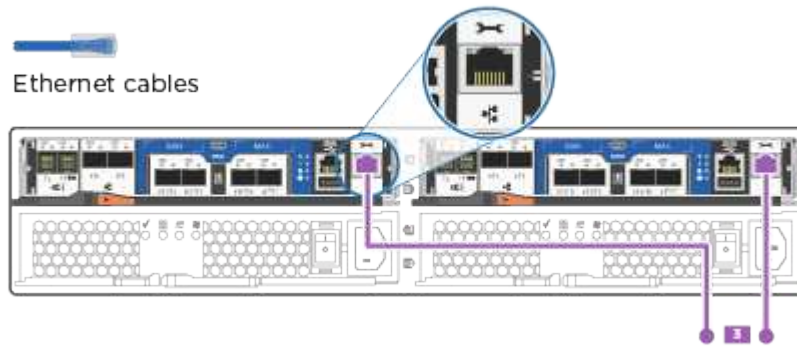

DO NOT plug in the power cords at this point.

### Option 2: Switched cluster

Learn how to cable a switched cluster.

#### Before you begin

Be sure to check the illustration arrow for the proper cable connector pull-tab orientation.

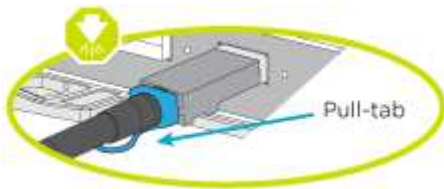

As you insert the connector, you should feel it click into place; if you do not feel it click, remove it, turn it around and try again.

#### About this task

You can use either the UTA2 data network ports or the ethernet data network ports to connect the controllers to your host network. Refer to the following cabling illustrations when cabling between the controllers and the switches.

#### Unified network cabling

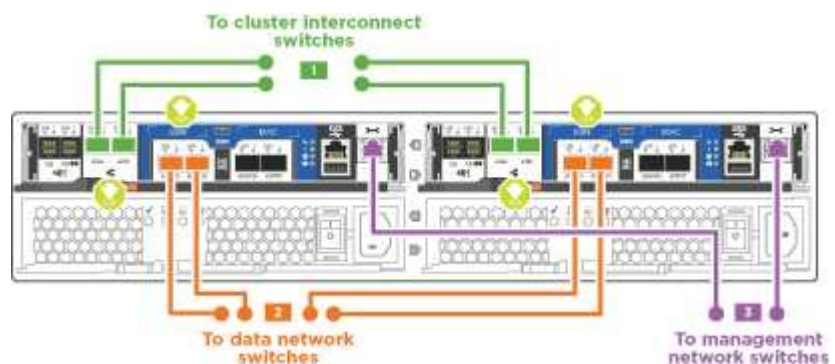

# Ethernet network cabling

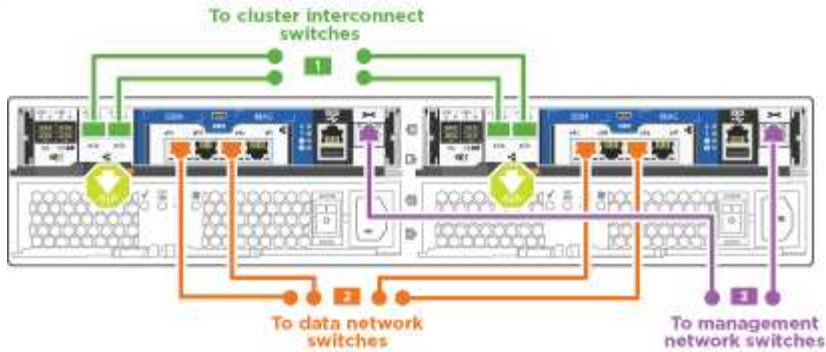

Perform the following steps on each controller module.

### Steps

1. For each controller module, cable e0a and e0b to the cluster interconnect switches with the cluster interconnect cable.



Cluster interconnect cables

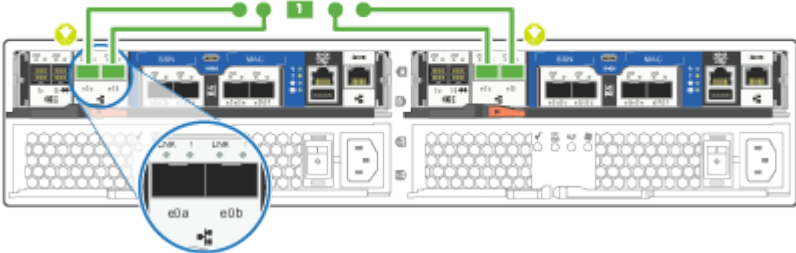

2. Do one of the following:

### UTA2 data network configurations

Use one of the following cable types to cable the UTA2 data ports to your host network.

- For an FC host, use 0c and 0d or 0e and 0f.
- For an 10GbE system, use e0c and e0d or e0e and e0f.

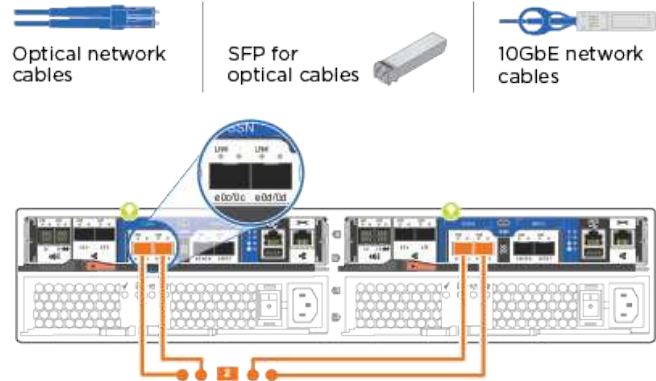

You can connect one port pair as CNA and one port pair as FC, or you can connect both port pairs as CNA or both port pairs as FC.

### Ethernet network configurations

Use the Cat 6 RJ45 cable to cable the e0c through e0f ports to your host network.

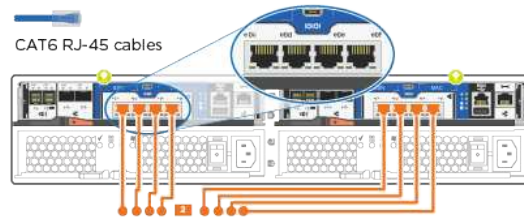

3. Cable the e0M ports to the management network switches with the RJ45 cables.

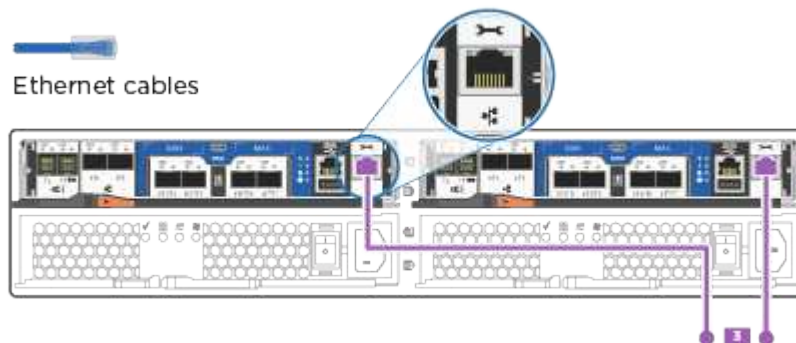



DO NOT plug in the power cords at this point.

#### Step 4: Cable controllers to drive shelves

Cable the controllers to your shelves using the onboard storage ports. NetApp recommends MP-HA cabling for systems with external storage.

##### About this task

If you have a SAS tape drive, you can use single-path cabling. If you have no external shelves, MP-HA cabling to internal drives is optional (not shown) if the SAS cables are ordered with the system.

You must cable the shelf-to-shelf connections, and then cable both controllers to the drive shelves.

Be sure to check the illustration arrow for the proper cable connector pull-tab orientation.

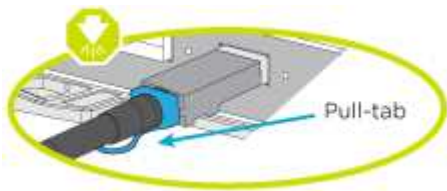

##### Steps

1. Cable the HA pair with external drive shelves.

The following example shows cabling for DS224C drive shelves. The cabling is similar with other supported drive shelves.

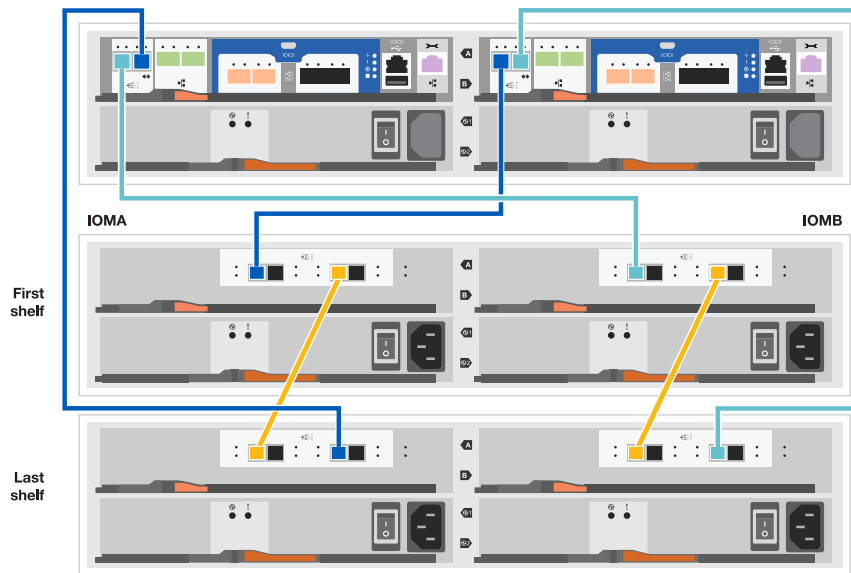

2. Cable the shelf-to-shelf ports.

- Port 3 on IOM A to port 1 on the IOM A on the shelf directly below.
- Port 3 on IOM B to port 1 on the IOM B on the shelf directly below.



3. Connect each node to IOM A in the stack.

- Controller 1 port 0b to IOM A port 3 on last drive shelf in the stack.
- Controller 2 port 0a to IOM A port 1 on the first drive shelf in the stack.

 mini-SAS HD to mini-SAS HD cables

4. Connect each node to IOM B in the stack

- Controller 1 port 0a to IOM B port 1 on first drive shelf in the stack.
- Controller 2 port 0b to IOM B port 3 on the last drive shelf in the stack.

 mini-SAS HD to mini-SAS HD cables

For additional cabling information, see [Install and cable shelves for a new system installation - shelves with IOM12/IOM12B modules](#).

### Step 5: Complete system setup

You can complete the system setup and configuration using cluster discovery with only a connection to the switch and laptop, or by connecting directly to a controller in the system and then connecting to the management switch.

### Option 1: If network discovery is enabled

If you have network discovery enabled on your laptop, you can complete system setup and configuration using automatic cluster discovery.

#### Steps

1. Use the following animation to set one or more drive shelf IDs

[Animation - Set drive shelf IDs](#)

2. Plug the power cords into the controller power supplies, and then connect them to power sources on different circuits.
3. Turn on the power switches to both nodes.



Initial booting may take up to eight minutes.

4. Make sure that your laptop has network discovery enabled.

See your laptop's online help for more information.

5. Use the following animation to connect your laptop to the Management switch.

[Animation - Connect your laptop to the Management switch](#)

6. Select an ONTAP icon listed to discover:

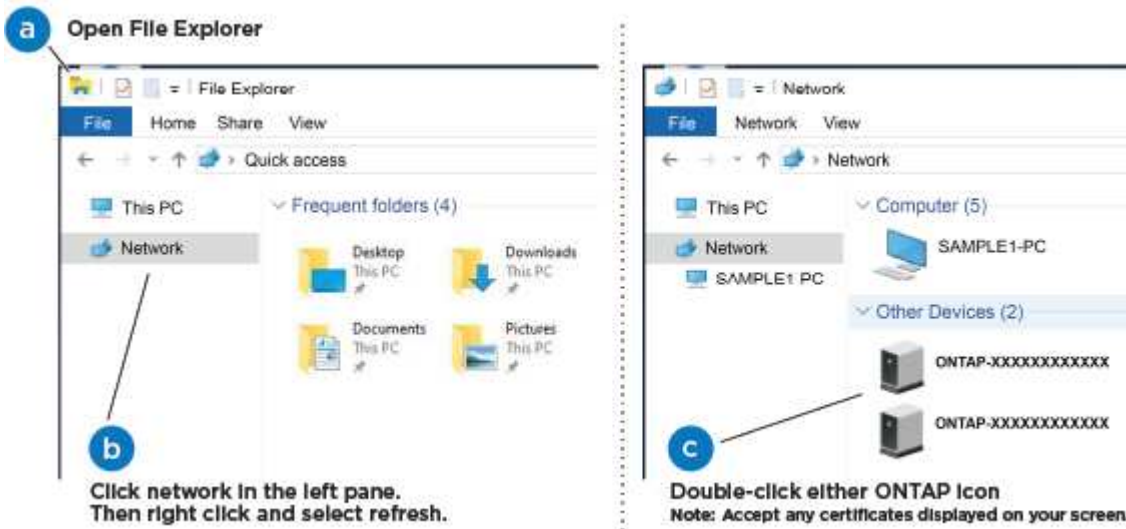

- a. Open File Explorer.

- b. Click network in the left pane.
- c. Right click and select refresh.
- d. Double-click either ONTAP icon and accept any certificates displayed on your screen.



XXXXX is the system serial number for the target node.

System Manager opens.

7. Configure the system using the data you collected in the [ONTAP Configuration Guide](#).
8. Set up your account and download Active IQ Config Advisor:
  - a. Log in to your [existing account or create and account](#).
  - b. [Register](#) your system.
  - c. Download [Active IQ Config Advisor](#).
9. Verify the health of your system by running Config Advisor.
10. After you have completed the initial configuration, go to the [ONTAP documentation](#) site for information about configuring additional features in ONTAP.

#### Option 2: If network discovery is not enabled

If network discovery is not enabled on your laptop, you must complete the configuration and setup using this task.

#### Steps

1. Cable and configure your laptop or console.
  - a. Set the console port on the laptop or console to 115,200 baud with N-8-1.  
  
See your laptop or console's online help for instructions on how to configure the console port.
  - b. Connect the console cable to the laptop or console, and connect the console port on the controller using the console cable that came with your system.

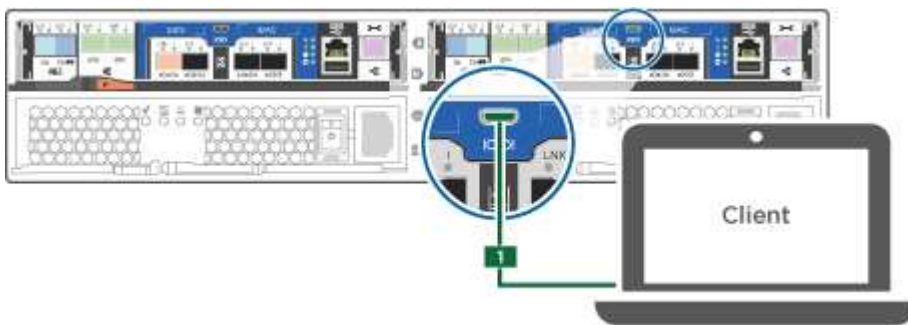

- c. Connect the laptop or console to the switch on the management subnet.

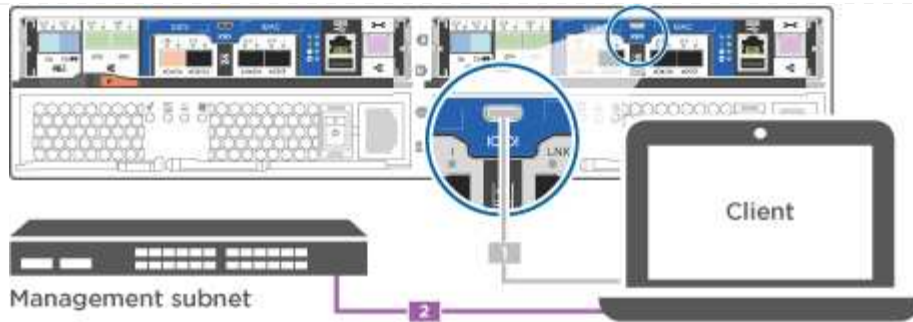

- d. Assign a TCP/IP address to the laptop or console, using one that is on the management subnet.
2. Use the following animation to set one or more drive shelf IDs:

[Animation - Set drive shelf IDs](#)

3. Plug the power cords into the controller power supplies, and then connect them to power sources on different circuits.
4. Turn on the power switches to both nodes.



**i** Initial booting may take up to eight minutes.

5. Assign an initial node management IP address to one of the nodes.

If the management network has DHCP...	Then...
Configured	Record the IP address assigned to the new controllers.
Not configured	<ol style="list-style-type: none"> <li>a. Open a console session using PuTTY, a terminal server, or the equivalent for your environment.</li> </ol> <p style="text-align: center;"><b>i</b> Check your laptop or console's online help if you do not know how to configure PuTTY.</p> <ol style="list-style-type: none"> <li>b. Enter the management IP address when prompted by the script.</li> </ol>

6. Using System Manager on your laptop or console, configure your cluster.
  - a. Point your browser to the node management IP address.





The format for the address is <https://x.x.x.x>.

- b. Configure the system using the data you collected in the [ONTAP Configuration Guide](#).
7. Set up your account and download Active IQ Config Advisor:
  - a. Log in to your [existing account or create and account](#).
  - b. [Register](#) your system.
  - c. Download [Active IQ Config Advisor](#).
8. Verify the health of your system by running Config Advisor.
9. After you have completed the initial configuration, go to the [ONTAP documentation](#) site for information about configuring additional features in ONTAP.

## Maintain

### Maintain ASA A150 hardware

For the ASA A150 storage system, you can perform maintenance procedures on the following components.

#### Boot media

The boot media stores a primary and secondary set of boot image files that the system uses when it boots.

#### Caching module

You must replace the controller's caching module when your system registers a single AutoSupport (ASUP) message that the module has gone offline.

#### Chassis

The chassis is the physical enclosure housing all the controller components such as the controller/CPU unit, power supply, and I/O.

#### Controller

A controller consists of a board, firmware, and software. It controls the drives and implements the ONTAP functions.

#### DIMM

You must replace a DIMM (dual in-line memory module) when a memory mismatch is present, or you have a failed DIMM.

#### Drive

A drive is a device that provides the physical storage media for data.

#### NVEM Battery

A battery is included with a controller and preserves cached data if the AC power fails.

## Power supply

A power supply provides a redundant power source in a controller shelf.

## Real time clock battery

A real time clock battery preserves system date and time information if the power is off.

## Boot media

### Overview of boot media replacement - ASA A150

The boot media stores a primary and secondary set of system (boot image) files that the system uses when it boots. Depending on your network configuration, you can perform either a nondisruptive or disruptive replacement.

You must have a USB flash drive, formatted to FAT32, with the appropriate amount of storage to hold the `image_XXX.tgz` file.

You also must copy the `image_XXX.tgz` file to the USB flash drive for later use in this procedure.

- The nondisruptive and disruptive methods for replacing a boot media both require you to restore the `var` file system:
  - For nondisruptive replacement, the HA pair must be connected to a network to restore the `var` file system.
  - For disruptive replacement, you do not need a network connection to restore the `var` file system, but the process requires two reboots.
- You must replace the failed component with a replacement FRU component you received from your provider.
- It is important that you apply the commands in these steps on the correct node:
  - The *impaired* node is the node on which you are performing maintenance.
  - The *healthy node* is the HA partner of the impaired node.

### Check onboard encryption keys - ASA A150

Prior to shutting down the impaired controller and checking the status of the onboard encryption keys, you must check the status of the impaired controller, disable automatic giveback, and check which version of ONTAP is running on the system.

If you have a cluster with more than two nodes, it must be in quorum. If the cluster is not in quorum or a healthy controller shows false for eligibility and health, you must correct the issue before shutting down the impaired controller; see the [Synchronize a node with the cluster](#).

## Steps

1. Check the status of the impaired controller:
  - If the impaired controller is at the login prompt, log in as `admin`.
  - If the impaired controller is at the LOADER prompt and is part of HA configuration, log in as `admin` on the healthy controller.

- If the impaired controller is in a standalone configuration and at LOADER prompt, contact [mysupport.netapp.com](http://mysupport.netapp.com).
2. If AutoSupport is enabled, suppress automatic case creation by invoking an AutoSupport message:
 

```
system node autosupport invoke -node * -type all -message
MAINT=number_of_hours_downh
```

The following AutoSupport message suppresses automatic case creation for two hours: `cluster1:*>`

```
system node autosupport invoke -node * -type all -message MAINT=2h
```
  3. Check the version of ONTAP the system is running on the impaired controller if up, or on the partner controller if the impaired controller is down, using the `version -v` command:
    - If `<Ino-DARE>` or `<1Ono-DARE>` is displayed in the command output, the system does not support NVE, proceed to shut down the controller.
    - If `<Ino-DARE>` is not displayed in the command output, and the system is running ONTAP 9.5, go to [Option 1: Check NVE or NSE on systems running ONTAP 9.5 and earlier](#).
    - If `<Ino-DARE>` is not displayed in the command output, and the system is running ONTAP 9.6 or later, go to [Option 2: Check NVE or NSE on systems running ONTAP 9.6 and later](#).
  4. If the impaired controller is part of an HA configuration, disable automatic giveback from the healthy controller:
 

```
storage failover modify -node local -auto-giveback false
```

 or
 

```
storage failover modify -node local -auto-giveback-after-panic false
```

### Option 1: Check NVE or NSE on systems running ONTAP 9.5 and earlier

Before shutting down the impaired controller, you need to check whether the system has either NetApp Volume Encryption (NVE) or NetApp Storage Encryption (NSE) enabled. If so, you need to verify the configuration.

#### Steps

1. Connect the console cable to the impaired controller.
2. Check whether NVE is configured for any volumes in the cluster:
 

```
volume show -is-encrypted true
```

If any volumes are listed in the output, NVE is configured and you need to verify the NVE configuration. If no volumes are listed, check whether NSE is configured.

3. Check whether NSE is configured:
 

```
storage encryption disk show
```

  - If the command output lists the drive details with Mode & Key ID information, NSE is configured and you need to verify the NSE configuration.
  - If NVE and NSE are not configured, it's safe to shut down the impaired controller.

### Verify NVE configuration

#### Steps

1. Display the key IDs of the authentication keys that are stored on the key management servers:
 

```
security key-manager query
```

  - If the `Restored` column displays `yes` and all key managers display `available`, it's safe to shut down the impaired controller.
  - If the `Restored` column displays anything other than `yes`, or if any key manager displays `unavailable`, you need to complete some additional steps.

- If you see the message This command is not supported when onboard key management is enabled, you need to complete some other additional steps.
2. If the Restored column displayed anything other than `yes`, or if any key manager displayed unavailable:
    - a. Retrieve and restore all authentication keys and associated key IDs: `security key-manager restore -address *`

If the command fails, contact NetApp Support.

[mysupport.netapp.com](https://mysupport.netapp.com)

    - b. Verify that the Restored column displays `yes` for all authentication keys and that all key managers display available: `security key-manager query`
    - c. Shut down the impaired controller.
  3. If you saw the message This command is not supported when onboard key management is enabled, display the keys stored in the onboard key manager: `security key-manager key show -detail`

- a. If the Restored column displays `yes` manually back up the onboard key management information:
  - Go to advanced privilege mode and enter `y` when prompted to continue: `set -priv advanced`
  - Enter the command to display the OKM backup information: `security key-manager backup show`
  - Copy the contents of the backup information to a separate file or your log file. You'll need it in disaster scenarios where you might need to manually recover OKM.
  - Return to admin mode: `set -priv admin`
  - Shut down the impaired controller.
- b. If the Restored column displays anything other than `yes`:
  - Run the key-manager setup wizard: `security key-manager setup -node target/impaired node name`



Enter the customer's onboard key management passphrase at the prompt. If the passphrase cannot be provided, contact [mysupport.netapp.com](https://mysupport.netapp.com)

- Verify that the Restored column displays `yes` for all authentication key: `security key-manager key show -detail`
- Go to advanced privilege mode and enter `y` when prompted to continue: `set -priv advanced`
- Enter the command to display the OKM backup information: `security key-manager backup show`
- Copy the contents of the backup information to a separate file or your log file. You'll need it in disaster scenarios where you might need to manually recover OKM.
- Return to admin mode: `set -priv admin`
- You can safely shutdown the controller.

## Verify NSE configuration

### Steps

1. Display the key IDs of the authentication keys that are stored on the key management servers: `security key-manager query`
  - If the `Restored` column displays `yes` and all key managers display `available`, it's safe to shut down the impaired controller.
  - If the `Restored` column displays anything other than `yes`, or if any key manager displays `unavailable`, you need to complete some additional steps.
  - If you see the message `This command is not supported when onboard key management is enabled`, you need to complete some other additional steps
2. If the `Restored` column displayed anything other than `yes`, or if any key manager displayed `unavailable`:
  - a. Retrieve and restore all authentication keys and associated key IDs: `security key-manager restore -address *`  
  
If the command fails, contact NetApp Support.  
  
[mysupport.netapp.com](https://mysupport.netapp.com)
  - b. Verify that the `Restored` column displays `yes` for all authentication keys and that all key managers display `available`: `security key-manager query`
  - c. Shut down the impaired controller.
3. If you saw the message `This command is not supported when onboard key management is enabled`, display the keys stored in the onboard key manager: `security key-manager key show -detail`
  - a. If the `Restored` column displays `yes`, manually back up the onboard key management information:
    - Go to advanced privilege mode and enter `y` when prompted to continue: `set -priv advanced`
    - Enter the command to display the OKM backup information: `security key-manager backup show`
    - Copy the contents of the backup information to a separate file or your log file. You'll need it in disaster scenarios where you might need to manually recover OKM.
    - Return to admin mode: `set -priv admin`
    - Shut down the impaired controller.
  - b. If the `Restored` column displays anything other than `yes`:
    - Run the key-manager setup wizard: `security key-manager setup -node target/impaired node name`  
  



 Enter the customer's OKM passphrase at the prompt. If the passphrase cannot be provided, contact [mysupport.netapp.com](https://mysupport.netapp.com)
    - Verify that the `Restored` column shows `yes` for all authentication keys: `security key-manager key show -detail`
    - Go to advanced privilege mode and enter `y` when prompted to continue: `set -priv advanced`

- Enter the command to back up the OKM information: `security key-manager backup show`



Make sure that OKM information is saved in your log file. This information will be needed in disaster scenarios where OKM might need to be manually recovered.

- Copy the contents of the backup information to a separate file or your log. You'll need it in disaster scenarios where you might need to manually recover OKM.
- Return to admin mode: `set -priv admin`
- You can safely shut down the controller.

## Option 2: Check NVE or NSE on systems running ONTAP 9.6 and later

Before shutting down the impaired controller, you need to verify whether the system has either NetApp Volume Encryption (NVE) or NetApp Storage Encryption (NSE) enabled. If so, you need to verify the configuration.

1. Verify whether NVE is in use for any volumes in the cluster: `volume show -is-encrypted true`

If any volumes are listed in the output, NVE is configured and you need to verify the NVE configuration. If no volumes are listed, check whether NSE is configured and in use.

2. Verify whether NSE is configured and in use: `storage encryption disk show`
  - If the command output lists the drive details with Mode & Key ID information, NSE is configured and you need to verify the NSE configuration and in use.
  - If no disks are shown, NSE is not configured.
  - If NVE and NSE are not configured, no drives are protected with NSE keys, it's safe to shut down the impaired controller.

## Verify NVE configuration

1. Display the key IDs of the authentication keys that are stored on the key management servers: `security key-manager key query`



After the ONTAP 9.6 release, you may have additional key manager types. The types are KMIP, AKV, and GCP. The process for confirming these types is the same as confirming external or onboard key manager types.

- If the Key Manager type displays `external` and the Restored column displays `yes`, it's safe to shut down the impaired controller.
  - If the Key Manager type displays `onboard` and the Restored column displays `yes`, you need to complete some additional steps.
  - If the Key Manager type displays `external` and the Restored column displays anything other than `yes`, you need to complete some additional steps.
  - If the Key Manager type displays `onboard` and the Restored column displays anything other than `yes`, you need to complete some additional steps.
2. If the Key Manager type displays `onboard` and the Restored column displays `yes`, manually back up the OKM information:
    - a. Go to advanced privilege mode and enter `y` when prompted to continue: `set -priv advanced`

- b. Enter the command to display the key management information: `security key-manager onboard show-backup`
  - c. Copy the contents of the backup information to a separate file or your log file. You'll need it in disaster scenarios where you might need to manually recover OKM.
  - d. Return to admin mode: `set -priv admin`
  - e. Shut down the impaired controller.
3. If the Key Manager type displays `external` and the Restored column displays anything other than `yes`:
- a. Restore the external key management authentication keys to all nodes in the cluster: `security key-manager external restore`

If the command fails, contact NetApp Support.

[mysupport.netapp.com](https://mysupport.netapp.com)

- b. Verify that the Restored column equals `yes` for all authentication keys: `security key-manager key query`
  - c. Shut down the impaired controller.
4. If the Key Manager type displays `onboard` and the Restored column displays anything other than `yes`:
- a. Enter the onboard security key-manager sync command: `security key-manager onboard sync`



Enter the customer's 32 character, alphanumeric onboard key management passphrase at the prompt. If the passphrase cannot be provided, contact NetApp Support.

[mysupport.netapp.com](https://mysupport.netapp.com)

- b. Verify the Restored column shows `yes` for all authentication keys: `security key-manager key query`
- c. Verify that the Key Manager type shows `onboard`, and then manually back up the OKM information.
- d. Go to advanced privilege mode and enter `y` when prompted to continue: `set -priv advanced`
- e. Enter the command to display the key management backup information: `security key-manager onboard show-backup`
- f. Copy the contents of the backup information to a separate file or your log file. You'll need it in disaster scenarios where you might need to manually recover OKM.
- g. Return to admin mode: `set -priv admin`
- h. You can safely shut down the controller.

## Verify NSE configuration

- 1. Display the key IDs of the authentication keys that are stored on the key management servers: `security key-manager key query -key-type NSE-AK`



After the ONTAP 9.6 release, you may have additional key manager types. The types are KMIP, AKV, and GCP. The process for confirming these types is the same as confirming external or onboard key manager types.

- If the Key Manager type displays `external` and the Restored column displays `yes`, it's safe to shut down the impaired controller.
  - If the Key Manager type displays `onboard` and the Restored column displays `yes`, you need to complete some additional steps.
  - If the Key Manager type displays `external` and the Restored column displays anything other than `yes`, you need to complete some additional steps.
  - If the Key Manager type displays `external` and the Restored column displays anything other than `yes`, you need to complete some additional steps.
2. If the Key Manager type displays `onboard` and the Restored column displays `yes`, manually back up the OKM information:
    - a. Go to advanced privilege mode and enter `y` when prompted to continue: `set -priv advanced`
    - b. Enter the command to display the key management information: `security key-manager onboard show-backup`
    - c. Copy the contents of the backup information to a separate file or your log file. You'll need it in disaster scenarios where you might need to manually recover OKM.
    - d. Return to admin mode: `set -priv admin`
    - e. You can safely shut down the controller.
  3. If the Key Manager type displays `external` and the Restored column displays anything other than `yes`:
    - a. Restore the external key management authentication keys to all nodes in the cluster: `security key-manager external restore`  
  
If the command fails, contact NetApp Support.  
  
[mysupport.netapp.com](https://mysupport.netapp.com)
    - b. Verify that the Restored column equals `yes` for all authentication keys: `security key-manager key query`
    - c. You can safely shut down the controller.
  4. If the Key Manager type displays `onboard` and the Restored column displays anything other than `yes`:
    - a. Enter the onboard security key-manager sync command: `security key-manager onboard sync`  
  
Enter the customer's 32 character, alphanumeric onboard key management passphrase at the prompt. If the passphrase cannot be provided, contact NetApp Support.  
  
[mysupport.netapp.com](https://mysupport.netapp.com)
    - b. Verify the Restored column shows `yes` for all authentication keys: `security key-manager key query`
    - c. Verify that the Key Manager type shows `onboard`, and then manually back up the OKM information.
    - d. Go to advanced privilege mode and enter `y` when prompted to continue: `set -priv advanced`
    - e. Enter the command to display the key management backup information: `security key-manager onboard show-backup`



- f. Copy the contents of the backup information to a separate file or your log file. You'll need it in disaster scenarios where you might need to manually recover OKM.
- g. Return to admin mode: `set -priv admin`
- h. You can safely shut down the controller.

### Shut down the impaired controller - ASA A150

Shut down or take over the impaired controller using the appropriate procedure for your configuration.

#### Option 1: Most configurations

After completing the NVE or NSE tasks, you need to complete the shutdown of the impaired controller.

#### Steps

- a. Take the impaired controller to the LOADER prompt:

If the impaired controller displays...	Then...
The LOADER prompt	Go to Remove controller module.
Waiting for giveback...	Press Ctrl-C, and then respond <code>y</code> when prompted.
System prompt or password prompt (enter system password)	Take over or halt the impaired controller from the healthy controller: <code>storage failover takeover -ofnode  impaired_node_name</code>  When the impaired controller shows Waiting for giveback..., press Ctrl-C, and then respond <code>y</code> .

- b. From the LOADER prompt, enter: `printenv` to capture all boot environmental variables. Save the output to your log file.



This command may not work if the boot device is corrupted or non-functional.

#### Option 2: Controller is in a MetroCluster

After completing the NVE or NSE tasks, you need to complete the shutdown of the impaired controller.



Do not use this procedure if your system is in a two-node MetroCluster configuration.

To shut down the impaired controller, you must determine the status of the controller and, if necessary, take over the controller so that the healthy controller continues to serve data from the impaired controller storage.

- If you have a cluster with more than two nodes, it must be in quorum. If the cluster is not in quorum or a healthy controller shows false for eligibility and health, you must correct the issue before shutting down the impaired controller; see [Synchronize a node with the cluster](#).

- If you have a MetroCluster configuration, you must have confirmed that the MetroCluster Configuration State is configured and that the nodes are in an enabled and normal state (`metrocluster node show`).

## Steps

1. If AutoSupport is enabled, suppress automatic case creation by invoking an AutoSupport message:

```
system node autosupport invoke -node * -type all -message
MAINT=number_of_hours_downh
```

The following AutoSupport message suppresses automatic case creation for two hours: `cluster1:*>`

```
system node autosupport invoke -node * -type all -message MAINT=2h
```

2. Disable automatic giveback from the console of the healthy controller: `storage failover modify -node local -auto-giveback false`
3. Take the impaired controller to the LOADER prompt:

If the impaired controller is displaying...	Then...
The LOADER prompt	Go to the next step.
Waiting for giveback...	Press Ctrl-C, and then respond <code>y</code> when prompted.
System prompt or password prompt (enter system password)	Take over or halt the impaired controller from the healthy controller: <pre>storage failover takeover -ofnode impaired_node_name</pre> <p>When the impaired controller shows Waiting for giveback..., press Ctrl-C, and then respond <code>y</code>.</p>

## Replace the boot media - ASA A150

To replace the boot media, you must remove the impaired controller module, install the replacement boot media, and transfer the boot image to a USB flash drive.

### Step 1: Remove the controller module

To access components inside the controller, you must first remove the controller module from the system and then remove the cover on the controller module.

1. If you are not already grounded, properly ground yourself.
2. Loosen the hook and loop strap binding the cables to the cable management device, and then unplug the system cables and SFPs (if needed) from the controller module, keeping track of where the cables were connected.

Leave the cables in the cable management device so that when you reinstall the cable management device, the cables are organized.

3. Remove and set aside the cable management devices from the left and right sides of the controller module.

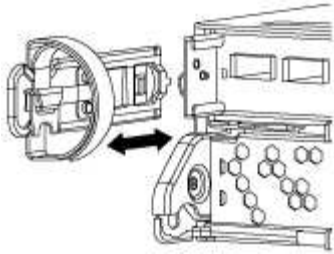

4. Squeeze the latch on the cam handle until it releases, open the cam handle fully to release the controller module from the midplane, and then, using two hands, pull the controller module out of the chassis.

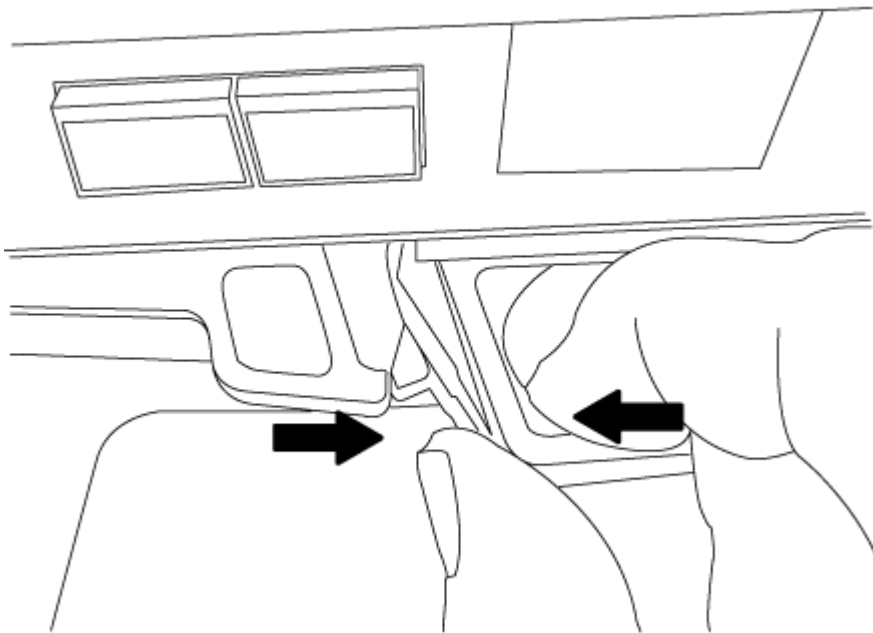

5. Turn the controller module over and place it on a flat, stable surface.
6. Open the cover by sliding in the blue tabs to release the cover, and then swing the cover up and open.

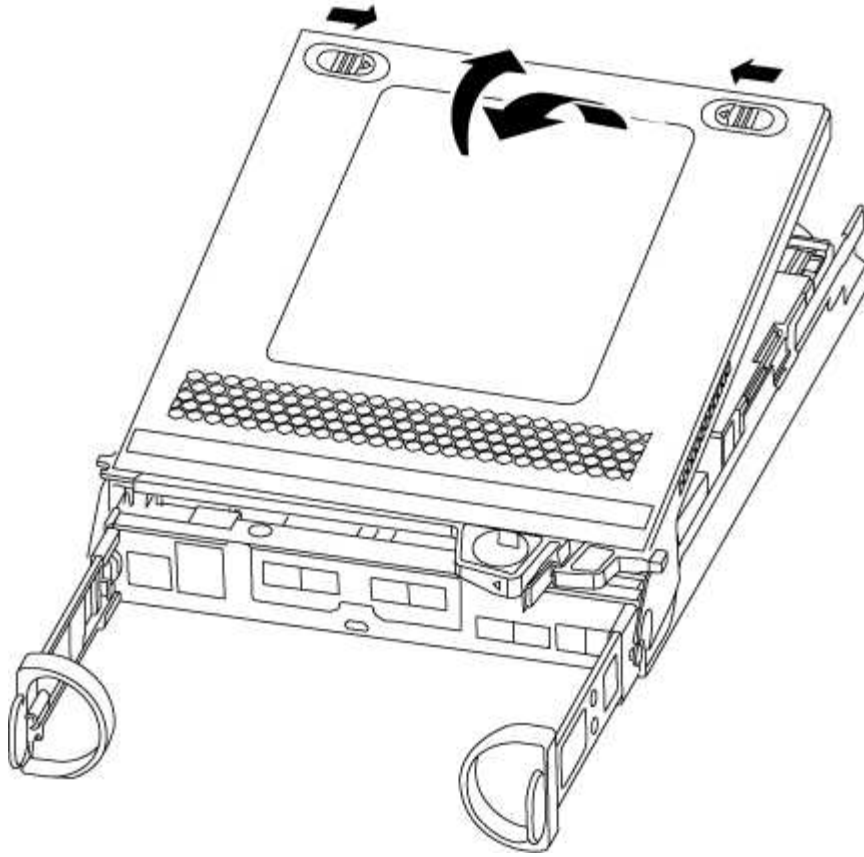

## Step 2: Replace the boot media

You must locate the boot media in the controller and follow the directions to replace it.

### Steps

1. If you are not already grounded, properly ground yourself.
2. Locate the boot media using the following illustration or the FRU map on the controller module:

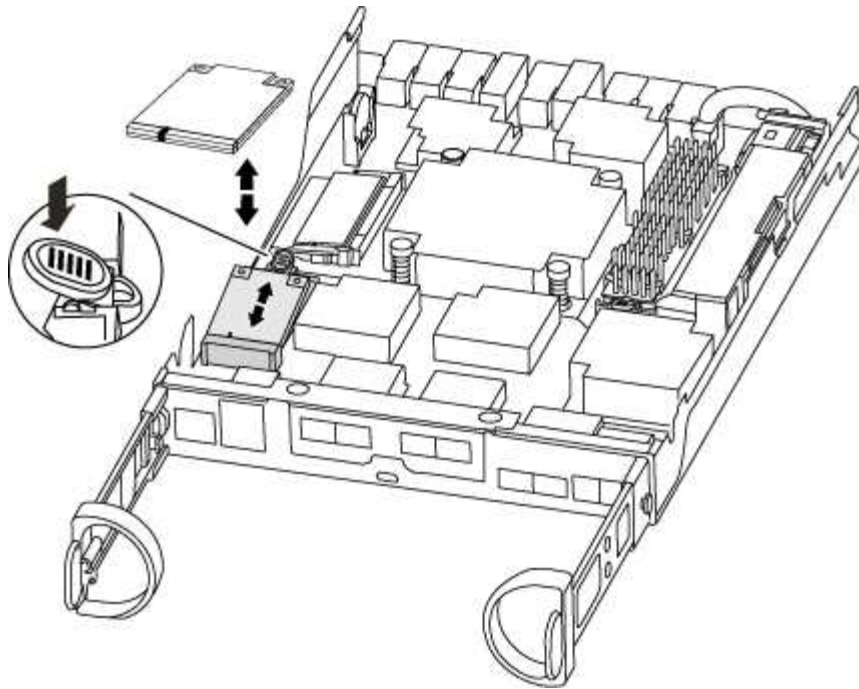

3. Press the blue button on the boot media housing to release the boot media from its housing, and then gently pull it straight out of the boot media socket.



Do not twist or pull the boot media straight up, because this could damage the socket or the boot media.

4. Align the edges of the replacement boot media with the boot media socket, and then gently push it into the socket.
5. Check the boot media to make sure that it is seated squarely and completely in the socket.

If necessary, remove the boot media and reseal it into the socket.

6. Push the boot media down to engage the locking button on the boot media housing.
7. Close the controller module cover.

### Step 3: Transfer the boot image to the boot media

You can install the system image to the replacement boot media using a USB flash drive with the image installed on it. However, you must restore the var file system during this procedure.

- You must have a USB flash drive, formatted to FAT32, with at least 4GB capacity.
- A copy of the same image version of ONTAP as what the impaired controller was running. You can download the appropriate image from the Downloads section on the NetApp Support Site
  - If NVE is enabled, download the image with NetApp Volume Encryption, as indicated in the download button.
  - If NVE is not enabled, download the image without NetApp Volume Encryption, as indicated in the download button.
- If your system is an HA pair, you must have a network connection.
- If your system is a stand-alone system you do not need a network connection, but you must perform an additional reboot when restoring the var file system.

## Steps

1. Align the end of the controller module with the opening in the chassis, and then gently push the controller module halfway into the system.
2. Reinstall the cable management device and recable the system, as needed.

When recabling, remember to reinstall the media converters (SFPs) if they were removed.

3. Insert the USB flash drive into the USB slot on the controller module.

Make sure that you install the USB flash drive in the slot labeled for USB devices, and not in the USB console port.

4. Push the controller module all the way into the system, making sure that the cam handle clears the USB flash drive, firmly push the cam handle to finish seating the controller module, push the cam handle to the closed position, and then tighten the thumbscrew.

The controller begins to boot as soon as it is completely installed into the chassis.

5. Interrupt the boot process to stop at the LOADER prompt by pressing Ctrl-C when you see Starting AUTOBOOT press Ctrl-C to abort....

If you miss this message, press Ctrl-C, select the option to boot to Maintenance mode, and then halt the controller to boot to LOADER.

6. For systems with one controller in the chassis, reconnect the power and turn on the power supplies.

The system begins to boot and stops at the LOADER prompt.

7. Set your network connection type at the LOADER prompt:

- If you are configuring DHCP: `ifconfig e0a -auto`



The target port you configure is the target port you use to communicate with the impaired controller from the healthy controller during var file system restore with a network connection. You can also use the e0M port in this command.

- If you are configuring manual connections: `ifconfig e0a -addr=filer_addr -mask=netmask -gw=gateway-dns=dns_addr-domain=dns_domain`
  - `filer_addr` is the IP address of the storage system.
  - `netmask` is the network mask of the management network that is connected to the HA partner.
  - `gateway` is the gateway for the network.
  - `dns_addr` is the IP address of a name server on your network.
  - `dns_domain` is the Domain Name System (DNS) domain name.

If you use this optional parameter, you do not need a fully qualified domain name in the netboot server URL. You need only the server's host name.



Other parameters might be necessary for your interface. You can enter `help ifconfig` at the firmware prompt for details.

## Boot the recovery image - ASA A150

You must boot the ONTAP image from the USB drive, restore the file system, and verify the environmental variables.

### Steps

1. From the LOADER prompt, boot the recovery image from the USB flash drive: `boot_recovery`

The image is downloaded from the USB flash drive.

2. When prompted, either enter the name of the image or accept the default image displayed inside the brackets on your screen.
3. Restore the var file system:

If your system has...	Then...
A network connection	<ol style="list-style-type: none"><li>a. Press <code>y</code> when prompted to restore the backup configuration.</li><li>b. Set the healthy controller to advanced privilege level: <code>set -privilege advanced</code></li><li>c. Run the restore backup command: <code>system node restore-backup -node local -target-address <i>impaired_node_IP_address</i></code></li><li>d. Return the controller to admin level: <code>set -privilege admin</code></li><li>e. Press <code>y</code> when prompted to use the restored configuration.</li><li>f. Press <code>y</code> when prompted to reboot the controller.</li></ol>
No network connection	<ol style="list-style-type: none"><li>a. Press <code>n</code> when prompted to restore the backup configuration.</li><li>b. Reboot the system when prompted by the system.</li><li>c. Select the <b>Update flash from backup config</b> (sync flash) option from the displayed menu.  If you are prompted to continue with the update, press <code>y</code>.</li></ol>

4. Ensure that the environmental variables are set as expected:
  - a. Take the controller to the LOADER prompt.
  - b. Check the environment variable settings with the `printenv` command.
  - c. If an environment variable is not set as expected, modify it with the `setenv environment-variable-name changed-value` command.
  - d. Save your changes using the `savenv` command.
5. The next depends on your system configuration:
  - If your system has onboard keymanager, NSE or NVE configured, go to [Restore OKM, NSE, and NVE as needed](#)
  - If your system does not have onboard keymanager, NSE or NVE configured, complete the steps in this

section.

6. From the LOADER prompt, enter the `boot_ontap` command.

If you see...	Then...
The login prompt	Go to the next Step.
Waiting for giveback...	<ol style="list-style-type: none"><li>a. Log into the partner controller.</li><li>b. Confirm the target controller is ready for giveback with the <code>storage failover show</code> command.</li></ol>

7. Connect the console cable to the partner controller.
8. Give back the controller using the `storage failover giveback -fromnode local` command.
9. At the cluster prompt, check the logical interfaces with the `net int -is-home false` command.

If any interfaces are listed as "false", revert those interfaces back to their home port using the `net int revert` command.

10. Move the console cable to the repaired controller and run the `version -v` command to check the ONTAP versions.
11. Restore automatic giveback if you disabled it by using the `storage failover modify -node local -auto-giveback true` command.

## Restore OKM, NSE, and NVE - ASA A150

Once environment variables are checked, you must complete steps specific to systems that have Onboard Key Manager (OKM), NetApp Storage Encryption (NSE) or NetApp Volume Encryption (NVE) enabled.

Determine which section you should use to restore your OKM, NSE, or NVE configurations:

If NSE or NVE are enabled along with Onboard Key Manager you must restore settings you captured at the beginning of this procedure.

- If NSE or NVE are enabled and Onboard Key Manager is enabled, go to [Option 1: Restore NVE or NSE when Onboard Key Manager is enabled](#).
- If NSE or NVE are enabled for ONATP 9.5, go to [Option 2: Restore NSE/NVE on systems running ONTAP 9.5 and earlier](#).
- If NSE or NVE are enabled for ONTAP 9.6, go to [Option 3: Restore NSE/NVE on systems running ONTAP 9.6 and later](#).

### Option 1: Restore NVE or NSE when Onboard Key Manager is enabled

#### Steps

1. Connect the console cable to the target controller.
2. Use the `boot_ontap` command at the LOADER prompt to boot the controller.
3. Check the console output:



If the console displays...	Then...
The LOADER prompt	Boot the controller to the boot menu: <code>boot_ontap menu</code>
Waiting for giveback...	<ul style="list-style-type: none"> <li>a. Enter <code>Ctrl-C</code> at the prompt</li> <li>b. At the message: <code>Do you wish to halt this controller rather than wait [y/n]?</code> , enter: <code>y</code></li> <li>c. At the LOADER prompt, enter the <code>boot_ontap menu</code> command.</li> </ul>

4. At the Boot Menu, enter the hidden command, `recover_onboard_keymanager` and reply `y` at the prompt.
5. Enter the passphrase for the onboard key manager you obtained from the customer at the beginning of this procedure.
6. When prompted to enter the backup data, paste the backup data you captured at the beginning of this procedure, when asked. Paste the output of `security key-manager backup show` OR `security key-manager onboard show-backup` command.



The data is output from either `security key-manager backup show` or `security key-manager onboard show-backup` command.

Example of backup data:

```

-----BEGIN BACKUP-----
TmV0QXBwIEtleSBCbG9iAAEAAAAEAAAAcAEAAAAAADuD+byAAAAACEAAAAAAAAA
QAAAAAAAAABvOIH0AAAAAMh7qDLRyH1DBz12piVdy9ATSFMT0C0TIYFss4PDjTaV
dzRYkLd1PhQLxAWJwOlyqSr8qY1SEBgm1IWgE5DLRqkiAAAAAAAAACgAAAAAAAA
3WTh7gAAAAAAAAAAAAAAAAAIAAAAAAAgAZJEIWvdeHr5RCAvHGclo+wAAAAAAAAA
lgAAAAAAAAAoAAAAAAAAEOTcR0AAAAAAAAAAAAAAAAACAAAAAAAAJAGr3tJA/
LRzUQRHwv+1aWvAAAAAAAAAAACQAAAAAAAAAgAAAAAAAAACdhTcvAAAAAJ1PXeBf
ml4NBsSyV1B4jc4A7cvWEFY6ILG6hc6tbKLAHZuvfQ4rlbYAAAAAAAAAAAAAAAAA
AAAAAAAAAAAAAAAAAAAAAAAAAAAAAAAAAAAAAAAAAAAAAAAAAAAAAAAAAAAAAAAA
AAAAAAAAAAAAAAAAAAAAAAAAAAAAAAAAAAAAAAAAAAAAAAAAAAAAAAAAAAAAAAAA
.
.
.
.
H4nPQM0nrDRYRa9SCv8AAAAAAAAAAAAAAAAAAAAAAAAAAAAAAAAAAAAAAAAAAAAA
AAAAAAAAAAAAAAAAAAAAAAAAAAAAAAAAAAAAAAAAAAAAAAAAAAAAAAAAAAAAAAAA
AAAAAAA
-----END BACKUP-----

```

7. At the Boot Menu select the option for Normal Boot.

The system boots to `Waiting for giveback...` prompt.

8. Move the console cable to the partner controller and login as admin.

9. Confirm the target controller is ready for giveback with the `storage failover show` command.
10. Give back only the CFO aggregates with the `storage failover giveback -fromnode local -only-cfo -aggregates true` command.
  - If the command fails because of a failed disk, physically disengage the failed disk, but leave the disk in the slot until a replacement is received.
  - If the command fails because of an open CIFS session, check with the customer on how to close out CIFS sessions.



Terminating CIFS can cause loss of data.

- If the command fails because the partner is "not ready", wait 5 minutes for the NVMEMs to synchronize.
  - If the command fails because of an NDMP, SnapMirror, or SnapVault process, disable the process. See the appropriate Documentation Center for more information.
11. Once the giveback completes, check the failover and giveback status with the `storage failover show` and `storage failover show-giveback`` commands.

Only the CFO aggregates (root aggregate and CFO style data aggregates) will be shown.

12. Move the console cable to the target controller.
13. If you are running ONTAP 9.5 and earlier, run the key-manager setup wizard:
  - a. Start the wizard using the `security key-manager setup -nodenodename` command, and then enter the passphrase for onboard key management when prompted.
  - b. Enter the `key-manager key show -detail` command to see a detailed view of all keys stored in the onboard key manager and verify that the `Restored` column = `yes` for all authentication keys.



If the `Restored` column = anything other than `yes`, contact Customer Support.

- c. Wait 10 minutes for the key to synchronize across the cluster.
14. If you are running ONTAP 9.6 or later:
  - a. Run the `security key-manager onboard sync` command and then enter the passphrase when prompted.
  - b. Enter the `security key-manager key query` command to see a detailed view of all keys stored in the onboard key manager and verify that the `Restored` column = `yes/true` for all authentication keys.



If the `Restored` column = anything other than `yes/true`, contact Customer Support.

- c. Wait 10 minutes for the key to synchronize across the cluster.
15. Move the console cable to the partner controller.
16. Give back the target controller using the `storage failover giveback -fromnode local` command.
17. Check the giveback status, 3 minutes after it reports complete, using the `storage failover show` command.

If giveback is not complete after 20 minutes, contact Customer Support.

18. At the clustershell prompt, enter the `net int show -is-home false` command to list the logical interfaces that are not on their home controller and port.

If any interfaces are listed as `false`, revert those interfaces back to their home port using the `net int revert -vserver Cluster -lif nodename` command.

19. Move the console cable to the target controller and run the `version -v` command to check the ONTAP versions.
20. Restore automatic giveback if you disabled it by using the `storage failover modify -node local -auto-giveback true` command.

## Option 2: Restore NSE/NVE on systems running ONTAP 9.5 and earlier

### Steps

1. Connect the console cable to the target controller.
2. Use the `boot_ontap` command at the LOADER prompt to boot the controller.
3. Check the console output:

If the console displays...	Then...
The login prompt	Go to Step 7.
Waiting for giveback...	<ol style="list-style-type: none"><li>a. Log into the partner controller.</li><li>b. Confirm the target controller is ready for giveback with the <code>storage failover show</code> command.</li></ol>

4. Move the console cable to the partner controller and give back the target controller storage using the `storage failover giveback -fromnode local -only-cfo-aggregates true local` command.
  - If the command fails because of a failed disk, physically disengage the failed disk, but leave the disk in the slot until a replacement is received.
  - If the command fails because of an open CIFS sessions, check with customer how to close out CIFS sessions.



Terminating CIFS can cause loss of data.

- If the command fails because the partner "not ready", wait 5 minutes for the NVMEMs to synchronize.
  - If the command fails because of an NDMP, SnapMirror, or SnapVault process, disable the process. See the appropriate Documentation Center for more information.
5. Wait 3 minutes and check the failover status with the `storage failover show` command.
  6. At the clustershell prompt, enter the `net int show -is-home false` command to list the logical interfaces that are not on their home controller and port.

If any interfaces are listed as `false`, revert those interfaces back to their home port using the `net int`

```
revert -vserver Cluster -lif nodename command.
```

7. Move the console cable to the target controller and run the `version -v` command to check the ONTAP versions.
8. Restore automatic giveback if you disabled it by using the `storage failover modify -node local -auto-giveback true` command.
9. Use the `storage encryption disk show` at the clustershell prompt, to review the output.



This command does not work if NVE (NetApp Volume Encryption) is configured

10. Use the `security key-manager query` to display the key IDs of the authentication keys that are stored on the key management servers.
  - If the `Restored` column = `yes` and all key managers report in an available state, go to *Complete the replacement process*.
  - If the `Restored` column = anything other than `yes`, and/or one or more key managers is not available, use the `security key-manager restore -address` command to retrieve and restore all authentication keys (AKs) and key IDs associated with all nodes from all available key management servers.

Check the output of the `security key-manager query` again to ensure that the `Restored` column = `yes` and all key managers report in an available state

11. If the Onboard Key Management is enabled:
  - a. Use the `security key-manager key show -detail` to see a detailed view of all keys stored in the onboard key manager.
  - b. Use the `security key-manager key show -detail` command and verify that the `Restored` column = `yes` for all authentication keys.

If the `Restored` column = anything other than `yes`, use the `security key-manager setup -node Repaired(Target)node` command to restore the Onboard Key Management settings. Rerun the `security key-manager key show -detail` command to verify `Restored` column = `yes` for all authentication keys.

12. Connect the console cable to the partner controller.
13. Give back the controller using the `storage failover giveback -fromnode local` command.
14. Restore automatic giveback if you disabled it by using the `storage failover modify -node local -auto-giveback true` command.

### Option 3: Restore NSE/NVE on systems running ONTAP 9.6 and later

#### Steps

1. Connect the console cable to the target controller.
2. Use the `boot_ontap` command at the LOADER prompt to boot the controller.
3. Check the console output:

If the console displays...	Then...
The login prompt	Go to Step 7.
Waiting for giveback...	<ul style="list-style-type: none"> <li>a. Log into the partner controller.</li> <li>b. Confirm the target controller is ready for giveback with the <code>storage failover show</code> command.</li> </ul>

4. Move the console cable to the partner controller and give back the target controller storage using the `storage failover giveback -fromnode local -only-cfo-aggregates true local` command.
  - If the command fails because of a failed disk, physically disengage the failed disk, but leave the disk in the slot until a replacement is received.
  - If the command fails because of an open CIFS session, check with the customer on how to close out CIFS sessions.



Terminating CIFS can cause loss of data.

- If the command fails because the partner is "not ready", wait 5 minutes for the NVMEMs to synchronize.
  - If the command fails because of an NDMP, SnapMirror, or SnapVault process, disable the process. See the appropriate Documentation Center for more information.
5. Wait 3 minutes and check the failover status with the `storage failover show` command.
  6. At the clustershell prompt, enter the `net int show -is-home false` command to list the logical interfaces that are not on their home controller and port.

If any interfaces are listed as `false`, revert those interfaces back to their home port using the `net int revert -vserver Cluster -lif nodename` command.

7. Move the console cable to the target controller and run the `version -v` command to check the ONTAP versions.
8. Restore automatic giveback if you disabled it by using the `storage failover modify -node local -auto-giveback true` command.
9. Use the `storage encryption disk show` at the clustershell prompt, to review the output.
10. Use the `security key-manager key query` command to display the key IDs of the authentication keys that are stored on the key management servers.
  - If the `Restored` column = `yes/true`, you are done and can proceed to complete the replacement process.
  - If the `Key Manager type` = `external` and the `Restored` column = anything other than `yes/true`, use the `security key-manager external restore` command to restore the key IDs of the authentication keys.



If the command fails, contact Customer Support.

- If the `Key Manager type = onboard` and the `Restored` column = anything other than `yes/true`, use the `security key-manager onboard sync` command to re-sync the Key Manager type.

Use the `security key-manager key query` to verify that the `Restored` column = `yes/true` for all authentication keys.

11. Connect the console cable to the partner controller.
12. Give back the controller using the `storage failover giveback -fromnode local` command.
13. Restore automatic giveback if you disabled it by using the `storage failover modify -node local -auto-giveback true` command.
14. If AutoSupport is enabled, restore/unsuppress automatic case creation by using the `system node autosupport invoke -node * -type all -message MAINT=END`

### Return the failed part to NetApp - ASA A150

Return the failed part to NetApp, as described in the RMA instructions shipped with the kit. See the [Part Return and Replacements](#) page for further information.

### Replace the caching module - ASA A150

You must replace the caching module in the controller module when your system registers a single AutoSupport (ASUP) message that the module has gone offline; failure to do so results in performance degradation.

Replace the failed component with a replacement FRU component you received from your provider.

#### Step 1: Shut down the impaired controller

To shut down the impaired controller, you must determine the status of the controller and, if necessary, take over the controller so that the healthy controller continues to serve data from the impaired controller storage.

#### About this task

If you have a cluster with more than two nodes, it must be in quorum. If the cluster is not in quorum or a healthy controller shows false for eligibility and health, you must correct the issue before shutting down the impaired controller; see [Synchronize a node with the cluster](#).

You might want to erase the contents of your caching module before replacing it.

#### Steps

1. Although data on the caching module is encrypted, you might want to erase any data from the impaired caching module and verify that the caching module has no data:
  - a. Erase the data on the caching module: `system controller flash-cache secure-erase run`
  - b. Verify that the data has been erased from the caching module: `system controller flash-cache secure-erase show -node node_name`

The output should display the caching module status as erased.

2. If the impaired controller is part of an HA pair, disable automatic giveback from the console of the healthy

```
controller: storage failover modify -node local -auto-giveback false
```

3. Take the impaired controller to the LOADER prompt:

If the impaired controller is displaying...	Then...
The LOADER prompt	Go to the next step.
Waiting for giveback...	Press Ctrl-C, and then respond <i>y</i> when prompted.
System prompt or password prompt (enter system password)	Take over or halt the impaired controller: <ul style="list-style-type: none"><li>• For an HA pair, take over the impaired controller from the healthy controller: <code>storage failover takeover -ofnode <i>impaired_node_name</i></code>  When the impaired controller shows Waiting for giveback..., press Ctrl-C, and then respond <i>y</i>.</li><li>• For a stand-alone system: <code>system node halt <i>impaired_node_name</i></code></li></ul>

4. If the system has only one controller module in the chassis, turn off the power supplies, and then unplug the impaired controller's power cords from the power source.

## Step 2: Remove controller module

To access components inside the controller, you must first remove the controller module from the system and then remove the cover on the controller module.

### Steps

1. If you are not already grounded, properly ground yourself.
2. Loosen the hook and loop strap binding the cables to the cable management device, and then unplug the system cables and SFPs (if needed) from the controller module, keeping track of where the cables were connected.

Leave the cables in the cable management device so that when you reinstall the cable management device, the cables are organized.

3. Remove and set aside the cable management devices from the left and right sides of the controller module.

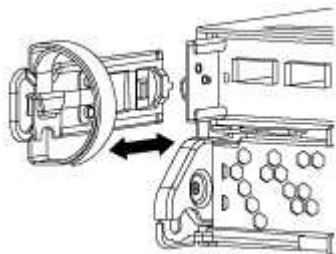

4. Squeeze the latch on the cam handle until it releases, open the cam handle fully to release the controller module from the midplane, and then, using two hands, pull the controller module out of the chassis.

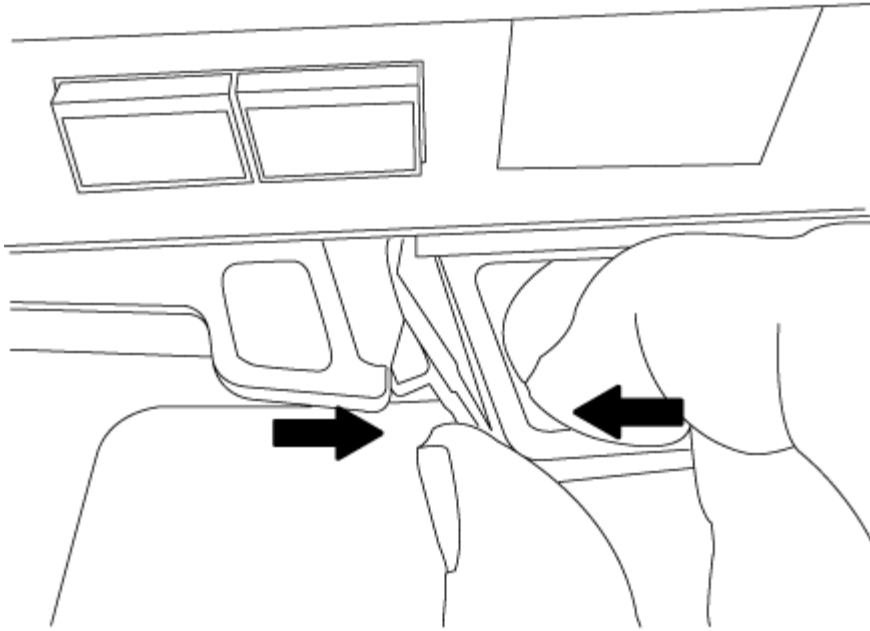

5. Turn the controller module over and place it on a flat, stable surface.
6. Open the cover by sliding in the blue tabs to release the cover, and then swing the cover up and open.

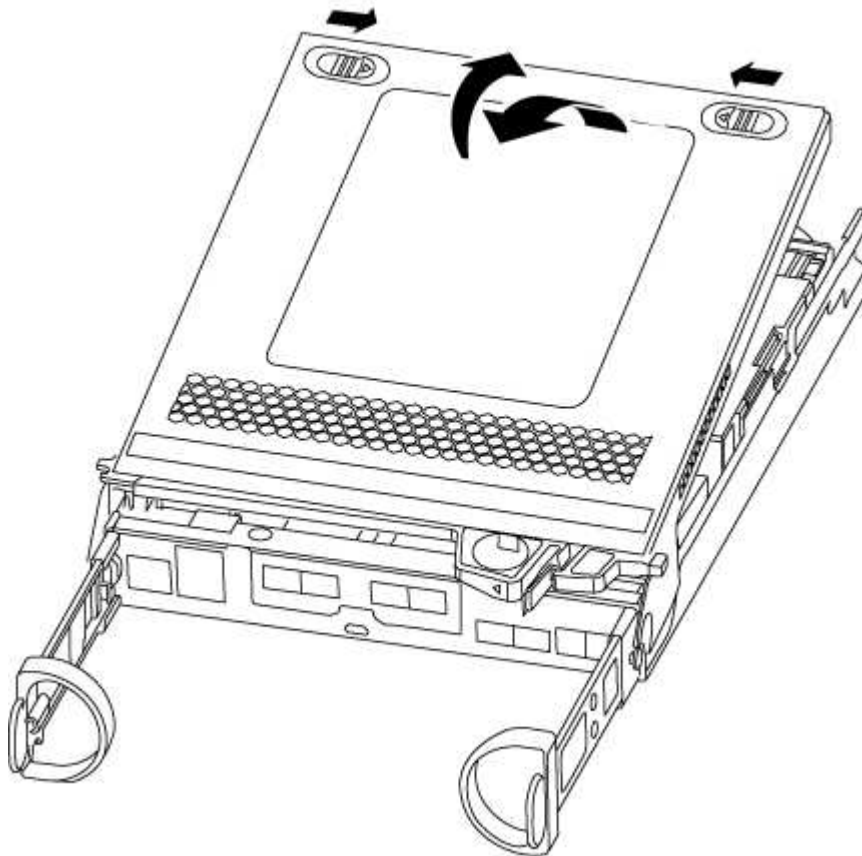

### Step 3: Replace a caching module

To replace a caching module referred to as the M.2 PCIe card on the label on your controller, locate the slot inside the controller and follow the specific sequence of steps.



Your storage system must meet certain criteria depending on your situation:

- It must have the appropriate operating system for the caching module you are installing.
- It must support the caching capacity.
- All other components in the storage system must be functioning properly; if not, you must contact technical support.

### Steps

1. If you are not already grounded, properly ground yourself.
2. Locate the caching module at the rear of the controller module and remove it.
  - a. Press the release tab.
  - b. Remove the heatsink.

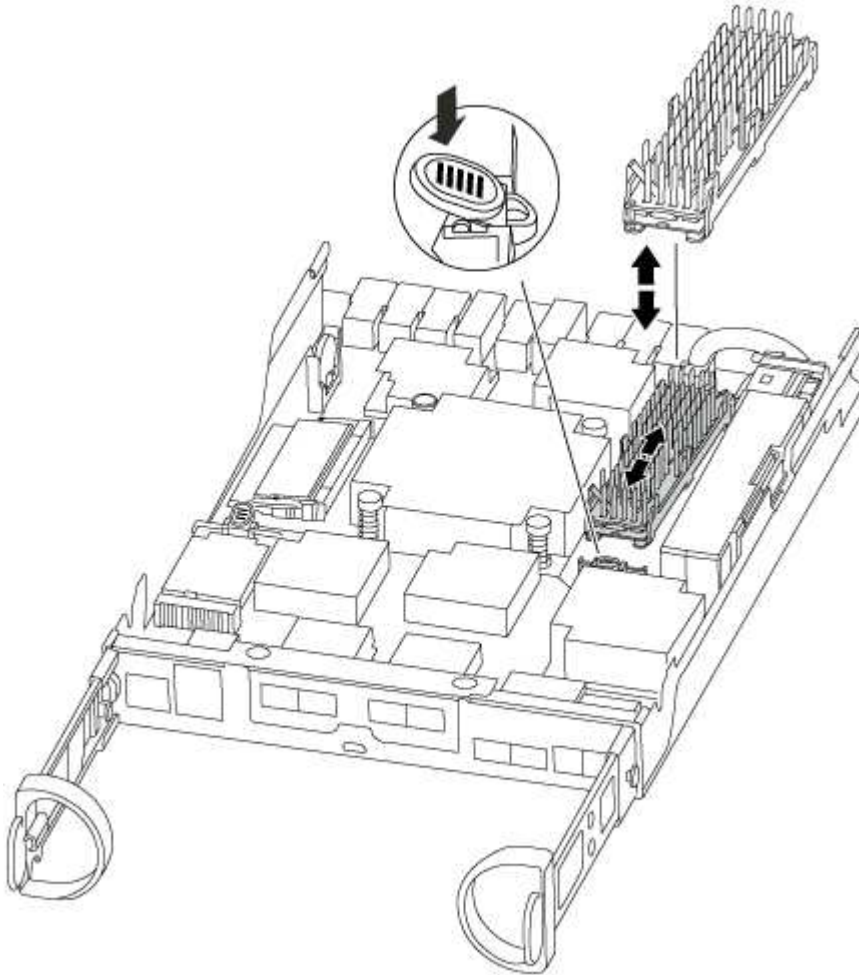

3. Gently pull the caching module straight out of the housing.
4. Align the edges of the caching module with the socket in the housing, and then gently push it into the socket.
5. Verify that the caching module is seated squarely and completely in the socket.

If necessary, remove the caching module and reseal it into the socket.

6. Reseat and push the heatsink down to engage the locking button on the caching module housing.

7. Close the controller module cover, as needed.

#### Step 4: Reinstall the controller module

After you replace components in the controller module, reinstall it into the chassis.

##### Steps

1. If you are not already grounded, properly ground yourself.
2. If you have not already done so, replace the cover on the controller module.
3. Align the end of the controller module with the opening in the chassis, and then gently push the controller module halfway into the system.



Do not completely insert the controller module in the chassis until instructed to do so.

4. Recable the system, as needed.

If you removed the media converters (QSFPs or SFPs), remember to reinstall them if you are using fiber optic cables.

5. Complete the reinstallation of the controller module:

If your system is in...	Then perform these steps...
An HA pair	<p>The controller module begins to boot as soon as it is fully seated in the chassis. Be prepared to interrupt the boot process.</p> <ol style="list-style-type: none"><li>a. With the cam handle in the open position, firmly push the controller module in until it meets the midplane and is fully seated, and then close the cam handle to the locked position.</li></ol> <div data-bbox="699 1199 760 1253"></div> <p>Do not use excessive force when sliding the controller module into the chassis to avoid damaging the connectors.</p> <p>The controller begins to boot as soon as it is seated in the chassis.</p> <ol style="list-style-type: none"><li>b. If you have not already done so, reinstall the cable management device.</li><li>c. Bind the cables to the cable management device with the hook and loop strap.</li></ol>

If your system is in...	Then perform these steps...
A stand-alone configuration	<p>a. With the cam handle in the open position, firmly push the controller module in until it meets the midplane and is fully seated, and then close the cam handle to the locked position.</p> <div style="border: 1px solid black; padding: 5px; margin: 10px 0;">  Do not use excessive force when sliding the controller module into the chassis to avoid damaging the connectors. </div> <p>b. If you have not already done so, reinstall the cable management device.</p> <p>c. Bind the cables to the cable management device with the hook and loop strap.</p> <p>d. Reconnect the power cables to the power supplies and to the power sources, turn on the power to start the boot process.</p>

### Step 5: Switch back aggregates in a two-node MetroCluster configuration

After you have completed the FRU replacement in a two-node MetroCluster configuration, you can perform the MetroCluster switchback operation. This returns the configuration to its normal operating state, with the sync-source storage virtual machines (SVMs) on the formerly impaired site now active and serving data from the local disk pools.

This task only applies to two-node MetroCluster configurations.

#### Steps

1. Verify that all nodes are in the enabled state: `metrocluster node show`

```
cluster_B::> metrocluster node show

DR                               Configuration  DR
Group Cluster Node              State          Mirroring Mode
-----
1      cluster_A
      controller_A_1 configured    enabled    heal roots
completed
      cluster_B
      controller_B_1 configured    enabled    waiting for
switchback recovery
2 entries were displayed.
```

2. Verify that resynchronization is complete on all SVMs: `metrocluster vserver show`

3. Verify that any automatic LIF migrations being performed by the healing operations were completed successfully: `metrocluster check lif show`
4. Perform the switchback by using the `metrocluster switchback` command from any node in the surviving cluster.
5. Verify that the switchback operation has completed: `metrocluster show`

The switchback operation is still running when a cluster is in the `waiting-for-switchback` state:

```
cluster_B::> metrocluster show
Cluster          Configuration State      Mode
-----
Local: cluster_B configured      switchover
Remote: cluster_A configured      waiting-for-switchback
```

The switchback operation is complete when the clusters are in the `normal` state.:

```
cluster_B::> metrocluster show
Cluster          Configuration State      Mode
-----
Local: cluster_B configured      normal
Remote: cluster_A configured      normal
```

If a switchback is taking a long time to finish, you can check on the status of in-progress baselines by using the `metrocluster config-replication resync-status show` command.

6. Reestablish any SnapMirror or SnapVault configurations.

### Step 6: Return the failed part to NetApp

Return the failed part to NetApp, as described in the RMA instructions shipped with the kit. See the [Part Return and Replacements](#) page for further information.

#### Chassis

##### Overview of chassis replacement - ASA A150

To replace the chassis, you must move the power supplies, hard drives, and controller module or modules from the impaired chassis to the new chassis, and swap out the impaired chassis from the equipment rack or system cabinet with the new chassis of the same model as the impaired chassis.

All other components in the system must be functioning properly; if not, you must contact technical support.

- You can use this procedure with all versions of ONTAP supported by your system.
- This procedure is written with the assumption that you are moving all drives and controller module or modules to the new chassis, and that the chassis is a new component from NetApp.

- This procedure is disruptive. For a two-controller cluster, you will have a complete service outage and a partial outage in a multi-node cluster.

## Shut down the controllers - ASA A150

Shut down or take over the impaired controller using the appropriate procedure for your configuration.

### Option 1: Most configurations

This procedure is for 2-node, non-MetroCluster configurations only. If you have a system with more than two nodes, see [How to perform a graceful shutdown and power up of one HA pair in a 4-node cluster](#).

#### Before you begin

You need:

- Local administrator credentials for ONTAP.
- NetApp onboard key management (OKM) cluster-wide passphrase if using storage encryption or NVE/NAE.
- BMC accessibility for each controller.
- Stop all clients/host from accessing data on the NetApp system.
- Suspend external backup jobs.
- Necessary tools and equipment for the replacement.



If the system is a NetApp StorageGRID or ONTAP S3 used as FabricPool cloud tier, refer to the [Gracefully shutdown and power up your storage system Resolution Guide](#) after performing this procedure.



If using SSDs, refer to [SU490: \(Impact: Critical\) SSD Best Practices: Avoid risk of drive failure and data loss if powered off for more than two months](#)

As a best practice before shutdown, you should:

- Perform additional [system health checks](#).
- Upgrade ONTAP to a recommended release for the system.
- Resolve any [Active IQ Wellness Alerts and Risks](#).  
Make note of any faults presently on the system, such as LEDs on the system components.

#### Steps

1. Log into the cluster through SSH or log in from any node in the cluster using a local console cable and a laptop/console.
2. Turn off AutoSupport and indicate how long you expect the system to be offline:

```
system node autosupport invoke -node * -type all -message "MAINT=8h Power Maintenance"
```

3. Identify the SP/BMC address of all nodes:

```
system service-processor show -node * -fields address
```

- Exit the cluster shell: `exit`
- Log into SP/BMC over SSH using the IP address of any of the nodes listed in the output from the previous step.

If you're using a console/laptop, log into the controller using the same cluster administrator credentials.



Open an SSH session to every SP/BMC connection so that you can monitor progress.

- Halt the 2 nodes located in the impaired chassis:

```
system node halt -node <node>,<node2> -skip-lif-migration-before-shutdown true
-ignore-quorum-warnings true -inhibit-takeover true
```



For clusters using SnapMirror synchronous operating in StrictSync mode: `system node halt -node <node>,<node2> -skip-lif-migration-before-shutdown true -ignore-quorum-warnings true -inhibit-takeover true -ignore-strict-sync-warnings true`

- Enter **y** for each controller in the cluster when you see *Warning: Are you sure you want to halt node "cluster <node-name> number"?*  
`{y|n}:`
- Wait for each controller to halt and display the LOADER prompt.

## Option 2: Controller is in a MetroCluster configuration



Do not use this procedure if your system is in a two-node MetroCluster configuration.

To shut down the impaired controller, you must determine the status of the controller and, if necessary, take over the controller so that the healthy controller continues to serve data from the impaired controller storage.

- If you have a cluster with more than two nodes, it must be in quorum. If the cluster is not in quorum or a healthy controller shows false for eligibility and health, you must correct the issue before shutting down the impaired controller; see [Synchronize a node with the cluster](#).
- If you have a MetroCluster configuration, you must have confirmed that the MetroCluster Configuration State is configured and that the nodes are in an enabled and normal state (`metrocluster node show`).

### Steps

- If AutoSupport is enabled, suppress automatic case creation by invoking an AutoSupport message:

```
system node autosupport invoke -node * -type all -message
MAINT=number_of_hours_downh
```

The following AutoSupport message suppresses automatic case creation for two hours: `cluster1:*> system node autosupport invoke -node * -type all -message MAINT=2h`

- Disable automatic giveback from the console of the healthy controller: `storage failover modify -node local -auto-giveback false`
- Take the impaired controller to the LOADER prompt:

If the impaired controller is displaying...	Then...
The LOADER prompt	Go to the next step.
Waiting for giveback...	Press Ctrl-C, and then respond <code>y</code> when prompted.
System prompt or password prompt (enter system password)	Take over or halt the impaired controller from the healthy controller: <pre>storage failover takeover -ofnode impaired_node_name</pre> When the impaired controller shows Waiting for giveback..., press Ctrl-C, and then respond <code>y</code> .

## Replace the chassis - ASA A150

Move the power supplies, hard drives, and controller module or modules from the impaired chassis to the new chassis, and swap out the impaired chassis from the equipment rack or system cabinet with the new chassis of the same model as the impaired chassis.

### Step 1: Move a power supply

Moving out a power supply when replacing a chassis involves turning off, disconnecting, and removing the power supply from the old chassis and installing and connecting it on the replacement chassis.

1. If you are not already grounded, properly ground yourself.
2. Turn off the power supply and disconnect the power cables:
  - a. Turn off the power switch on the power supply.
  - b. Open the power cable retainer, and then unplug the power cable from the power supply.
  - c. Unplug the power cable from the power source.
3. Squeeze the latch on the power supply cam handle, and then open the cam handle to fully release the power supply from the mid plane.
4. Use the cam handle to slide the power supply out of the system.



When removing a power supply, always use two hands to support its weight.

5. Repeat the preceding steps for any remaining power supplies.
6. Using both hands, support and align the edges of the power supply with the opening in the system chassis, and then gently push the power supply into the chassis using the cam handle.

The power supplies are keyed and can only be installed one way.



Do not use excessive force when sliding the power supply into the system. You can damage the connector.

7. Close the cam handle so that the latch clicks into the locked position and the power supply is fully seated.
8. Reconnect the power cable and secure it to the power supply using the power cable locking mechanism.



Only connect the power cable to the power supply. Do not connect the power cable to a power source at this time.

## Step 2: Remove the controller module

Remove the controller module or modules from the old chassis.

1. Loosen the hook and loop strap binding the cables to the cable management device, and then unplug the system cables and SFPs (if needed) from the controller module, keeping track of where the cables were connected.

Leave the cables in the cable management device so that when you reinstall the cable management device, the cables are organized.

2. Remove and set aside the cable management devices from the left and right sides of the controller module.

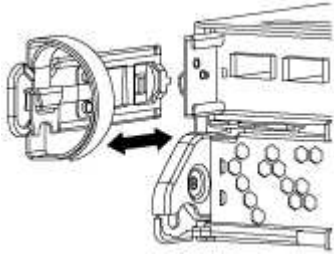

3. Squeeze the latch on the cam handle until it releases, open the cam handle fully to release the controller module from the midplane, and then, using two hands, pull the controller module out of the chassis.

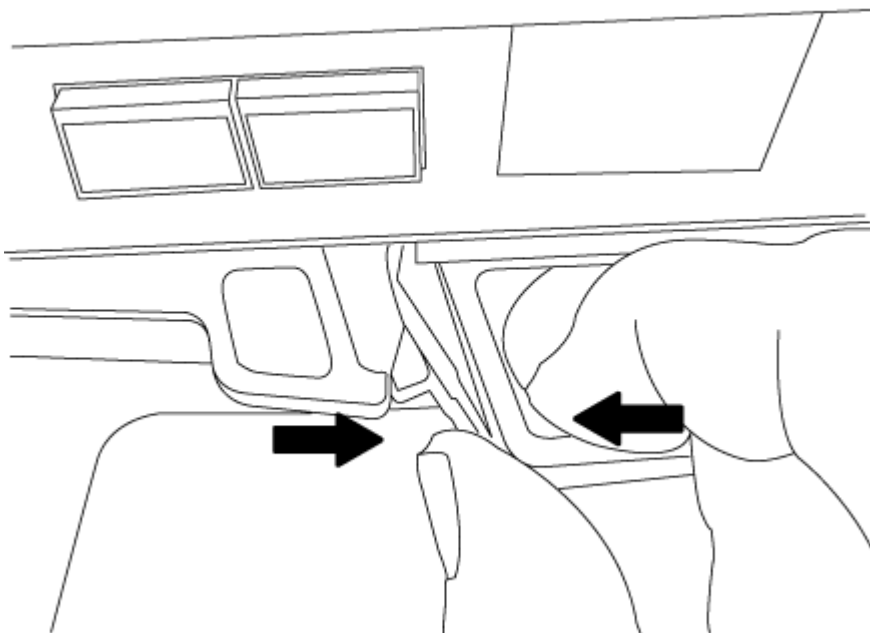

4. Set the controller module aside in a safe place, and repeat these steps if you have another controller module in the chassis.



### Step 3: Move drives to the new chassis

You need to move the drives from each bay opening in the old chassis to the same bay opening in the new chassis.

1. Gently remove the bezel from the front of the system.
2. Remove the drives:
  - a. Press the release button at the top of the carrier face below the LEDs.
  - b. Pull the cam handle to its fully open position to unseat the drive from the midplane, and then gently slide the drive out of the chassis.

The drive should disengage from the chassis, allowing it to slide free of the chassis.



When removing a drive, always use two hands to support its weight.



Drives are fragile. Handle them as little as possible to prevent damage to them.

3. Align the drive from the old chassis with the same bay opening in the new chassis.
4. Gently push the drive into the chassis as far as it will go.

The cam handle engages and begins to rotate upward.

5. Firmly push the drive the rest of the way into the chassis, and then lock the cam handle by pushing it up and against the drive holder.

Be sure to close the cam handle slowly so that it aligns correctly with the front of the drive carrier. It click when it is secure.

6. Repeat the process for the remaining drives in the system.

### Step 4: Replace a chassis from within the equipment rack or system cabinet

You must remove the existing chassis from the equipment rack or system cabinet before you can install the replacement chassis.

1. Remove the screws from the chassis mount points.
2. With the help of two or three people, slide the old chassis off the rack rails in a system cabinet or L brackets in an equipment rack, and then set it aside.
3. If you are not already grounded, properly ground yourself.
4. Using two or three people, install the replacement chassis into the equipment rack or system cabinet by guiding the chassis onto the rack rails in a system cabinet or L brackets in an equipment rack.
5. Slide the chassis all the way into the equipment rack or system cabinet.
6. Secure the front of the chassis to the equipment rack or system cabinet, using the screws you removed from the old chassis.
7. If you have not already done so, install the bezel.

### Step 5: Install the controller

After you install the controller module and any other components into the new chassis, boot it.



For HA pairs with two controller modules in the same chassis, the sequence in which you install the controller module is especially important because it attempts to reboot as soon as you completely seat it in the chassis.

1. Align the end of the controller module with the opening in the chassis, and then gently push the controller module halfway into the system.



Do not completely insert the controller module in the chassis until instructed to do so.

2. Recable the console to the controller module, and then reconnect the management port.
3. Repeat the preceding steps if there is a second controller to install in the new chassis.
4. Complete the installation of the controller module:

If your system is in...	Then perform these steps...
An HA pair	<ol style="list-style-type: none"> <li>a. With the cam handle in the open position, firmly push the controller module in until it meets the midplane and is fully seated, and then close the cam handle to the locked position.</li> </ol> <div style="margin-left: 40px;">  <p>Do not use excessive force when sliding the controller module into the chassis to avoid damaging the connectors.</p> </div> <ol style="list-style-type: none"> <li>b. If you have not already done so, reinstall the cable management device.</li> <li>c. Bind the cables to the cable management device with the hook and loop strap.</li> <li>d. Repeat the preceding steps for the second controller module in the new chassis.</li> </ol>
A stand-alone configuration	<ol style="list-style-type: none"> <li>a. With the cam handle in the open position, firmly push the controller module in until it meets the midplane and is fully seated, and then close the cam handle to the locked position.</li> </ol> <div style="margin-left: 40px;">  <p>Do not use excessive force when sliding the controller module into the chassis to avoid damaging the connectors.</p> </div> <ol style="list-style-type: none"> <li>b. If you have not already done so, reinstall the cable management device.</li> <li>c. Bind the cables to the cable management device with the hook and loop strap.</li> <li>d. Reinstall the blanking panel and then go to the next step.</li> </ol>

5. Connect the power supplies to different power sources, and then turn them on.
6. Boot each controller to Maintenance mode:
  - a. As each controller starts the booting, press `Ctrl-C` to interrupt the boot process when you see the message `Press Ctrl-C for Boot Menu`.



If you miss the prompt and the controller modules boot to ONTAP, enter `halt`, and then at the LOADER prompt enter `boot_ontap`, press `Ctrl-C` when prompted, and then repeat this step.

- b. From the boot menu, select the option for Maintenance mode.

## Restore and verify the configuration - ASA A150

You must verify the HA state of the chassis, switch back aggregates, and return the failed part to NetApp, as described in the RMA instructions shipped with the kit.

### Step 1: Verify and set the HA state of the chassis

You must verify the HA state of the chassis, and, if necessary, update the state to match your system configuration.

1. In Maintenance mode, from either controller module, display the HA state of the local controller module and chassis: `ha-config show`

The HA state should be the same for all components.

2. If the displayed system state for the chassis does not match your system configuration:
  - a. Set the HA state for the chassis: `ha-config modify chassis HA-state`

The value for HA-state can be one of the following:

- `ha`
- `mcc`
- `mcc-2n`
- `mccip`
- `non-ha`

- b. Confirm that the setting has changed: `ha-config show`
3. If you have not already done so, recable the rest of your system.
4. Reboot the system.

### Step 2: Switch back aggregates in a two-node MetroCluster configuration

After you have completed the FRU replacement in a two-node MetroCluster configuration, you can perform the MetroCluster switchback operation. This returns the configuration to its normal operating state, with the sync-source storage virtual machines (SVMs) on the formerly impaired site now active and serving data from the local disk pools.

This task only applies to two-node MetroCluster configurations.

#### Steps

1. Verify that all nodes are in the `enabled state`: `metrocluster node show`

```

cluster_B::> metrocluster node show

DR
Group Cluster Node          Configuration  DR
-----
-----
1      cluster_A
      controller_A_1 configured    enabled    heal roots
completed
      cluster_B
      controller_B_1 configured    enabled    waiting for
switchback recovery
2 entries were displayed.

```

2. Verify that resynchronization is complete on all SVMs: `metrocluster vserver show`
3. Verify that any automatic LIF migrations being performed by the healing operations were completed successfully: `metrocluster check lif show`
4. Perform the switchback by using the `metrocluster switchback` command from any node in the surviving cluster.
5. Verify that the switchback operation has completed: `metrocluster show`

The switchback operation is still running when a cluster is in the `waiting-for-switchback` state:

```

cluster_B::> metrocluster show
Cluster          Configuration State      Mode
-----
Local: cluster_B configured    switchover
Remote: cluster_A configured    waiting-for-switchback

```

The switchback operation is complete when the clusters are in the `normal` state.:

```

cluster_B::> metrocluster show
Cluster          Configuration State      Mode
-----
Local: cluster_B configured    normal
Remote: cluster_A configured    normal

```

If a switchback is taking a long time to finish, you can check on the status of in-progress baselines by using the `metrocluster config-replication resync-status show` command.

6. Reestablish any SnapMirror or SnapVault configurations.

### Step 3: Return the failed part to NetApp

Return the failed part to NetApp, as described in the RMA instructions shipped with the kit. See the [Part Return and Replacements](#) page for further information.

#### Controller

#### Overview of controller replacement - ASA A150

You must review the prerequisites for the replacement procedure and select the correct one for your version of the ONTAP operating system.

- All drive shelves must be working properly.
- If your system is in an HA pair, the healthy controller must be able to take over the controller that is being replaced (referred to in this procedure as the “impaired controller”).
- If your system is in a MetroCluster configuration, you must review the section [Choosing the correct recovery procedure](#) to determine whether you should use this procedure.

If this is the procedure you should use, note that the controller replacement procedure for a controller in a four or eight node MetroCluster configuration is the same as that in an HA pair. No MetroCluster-specific steps are required because the failure is restricted to an HA pair and storage failover commands can be used to provide nondisruptive operation during the replacement.

- This procedure includes steps for automatically or manually reassigning drives to the *replacement* controller, depending on your system’s configuration.

You should perform the drive reassignment as directed in the procedure.

- You must replace the failed component with a replacement FRU component you received from your provider.
- You must be replacing a controller module with a controller module of the same model type. You cannot upgrade your system by just replacing the controller module.
- You cannot change any drives or drive shelves as part of this procedure.
- In this procedure, the boot device is moved from the impaired controller to the *replacement* controller so that the *replacement* controller will boot up in the same version of ONTAP as the old controller module.
- It is important that you apply the commands in these steps on the correct systems:
  - The *impaired* controller is the controller that is being replaced.
  - The *replacement* controller is the new controller that is replacing the impaired controller.
  - The *healthy* controller is the surviving controller.
- You must always capture the controller’s console output to a text file.

This provides you a record of the procedure so that you can troubleshoot any issues that you might encounter during the replacement process.

#### Shut down the impaired controller - ASA A150

To shut down the impaired controller, you must determine the status of the controller and, if necessary, take over the controller so that the healthy controller continues to serve data from the impaired controller storage.

## About this task

- If you have a SAN system, you must have checked event messages (`cluster kernel-service show`) for the impaired controller SCSI blade. The `cluster kernel-service show` command (from `priv advanced` mode) displays the node name, quorum status of that node, availability status of that node, and operational status of that node.

Each SCSI-blade process should be in quorum with the other nodes in the cluster. Any issues must be resolved before you proceed with the replacement.

- If you have a cluster with more than two nodes, it must be in quorum. If the cluster is not in quorum or a healthy controller shows `false` for eligibility and health, you must correct the issue before shutting down the impaired controller; see [Synchronize a node with the cluster](#).

## Steps

1. If AutoSupport is enabled, suppress automatic case creation by invoking an AutoSupport message:  
`system node autosupport invoke -node * -type all -message MAINT=<# of hours>h`

The following AutoSupport message suppresses automatic case creation for two hours: `cluster1:>`  
`system node autosupport invoke -node * -type all -message MAINT=2h`

2. Disable automatic giveback from the console of the healthy controller: `storage failover modify -node local -auto-giveback false`



When you see *Do you want to disable auto-giveback?*, enter `y`.

3. Take the impaired controller to the LOADER prompt:

If the impaired controller is displaying...	Then...
The LOADER prompt	Go to the next step.
Waiting for giveback...	Press Ctrl-C, and then respond <code>y</code> when prompted.
System prompt or password prompt	Take over or halt the impaired controller from the healthy controller: <code>storage failover takeover -ofnode impaired_node_name</code>  When the impaired controller shows <code>Waiting for giveback...</code> , press Ctrl-C, and then respond <code>y</code> .

## Replace the controller - ASA A150

To replace the controller module hardware, you must remove the impaired controller, move FRU components to the replacement controller module, install the replacement controller module in the chassis, and then boot the system to Maintenance mode.

## Step 1: Remove controller module

To replace the controller module, you must first remove the old controller module from the chassis.

1. If you are not already grounded, properly ground yourself.
2. Loosen the hook and loop strap binding the cables to the cable management device, and then unplug the system cables and SFPs (if needed) from the controller module, keeping track of where the cables were connected.

Leave the cables in the cable management device so that when you reinstall the cable management device, the cables are organized.

3. Remove and set aside the cable management devices from the left and right sides of the controller module.

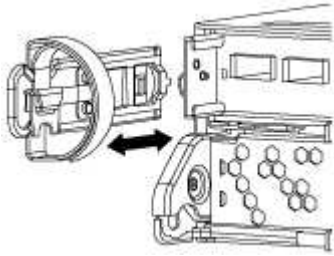

4. If you left the SFP modules in the system after removing the cables, move them to the new controller module.
5. Squeeze the latch on the cam handle until it releases, open the cam handle fully to release the controller module from the midplane, and then, using two hands, pull the controller module out of the chassis.

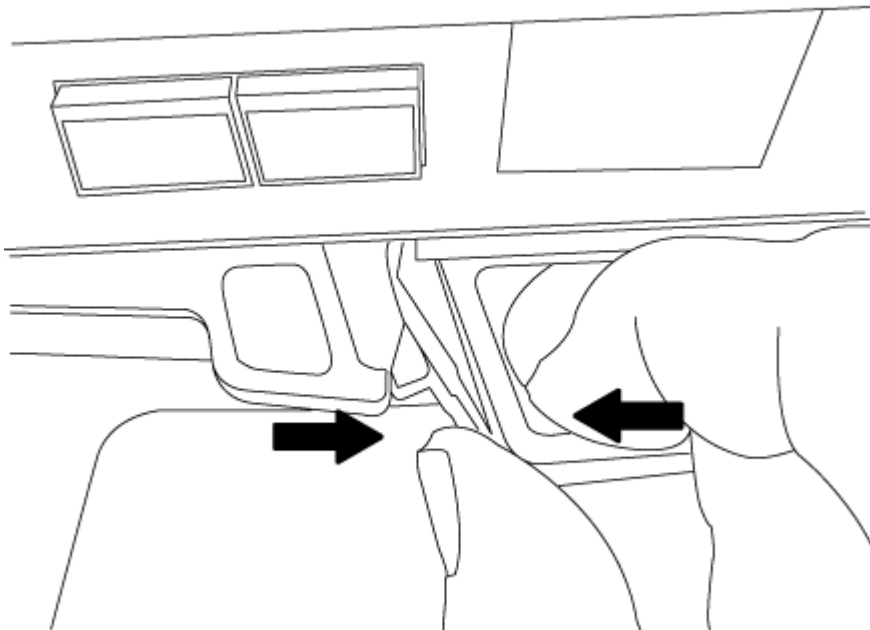

6. Turn the controller module over and place it on a flat, stable surface.
7. Open the cover by sliding in the blue tabs to release the cover, and then swing the cover up and open.

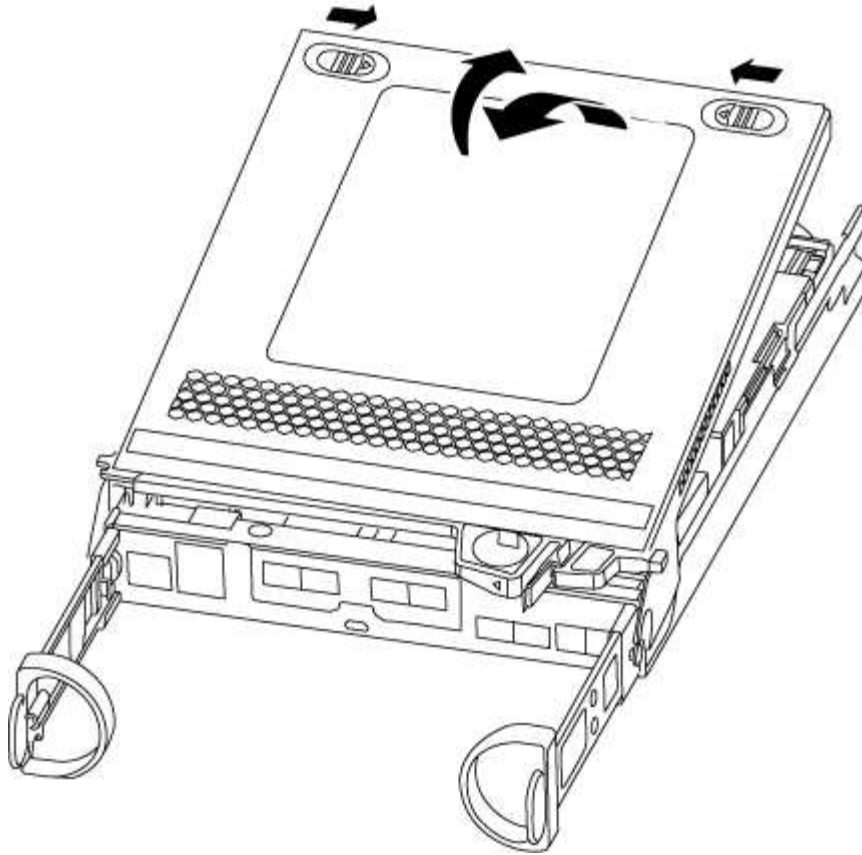

## Step 2: Move the NVMEM battery

To move the NVMEM battery from the old controller module to the new controller module, you must perform a specific sequence of steps.

### 1. Check the NVMEM LED:

- If your system is in an HA configuration, go to the next step.
- If your system is in a stand-alone configuration, cleanly shut down the controller module, and then check the NVRAM LED identified by the NV icon.



The NVRAM LED blinks while destaging contents to the flash memory when you halt the system. After the destage is complete, the LED turns off.

- If power is lost without a clean shutdown, the NVMEM LED flashes until the destage is complete, and then the LED turns off.
- If the LED is on and power is on, unwritten data is stored on NVMEM.

This typically occurs during an uncontrolled shutdown after ONTAP has successfully booted.

### 2. Locate the NVMEM battery in the controller module.



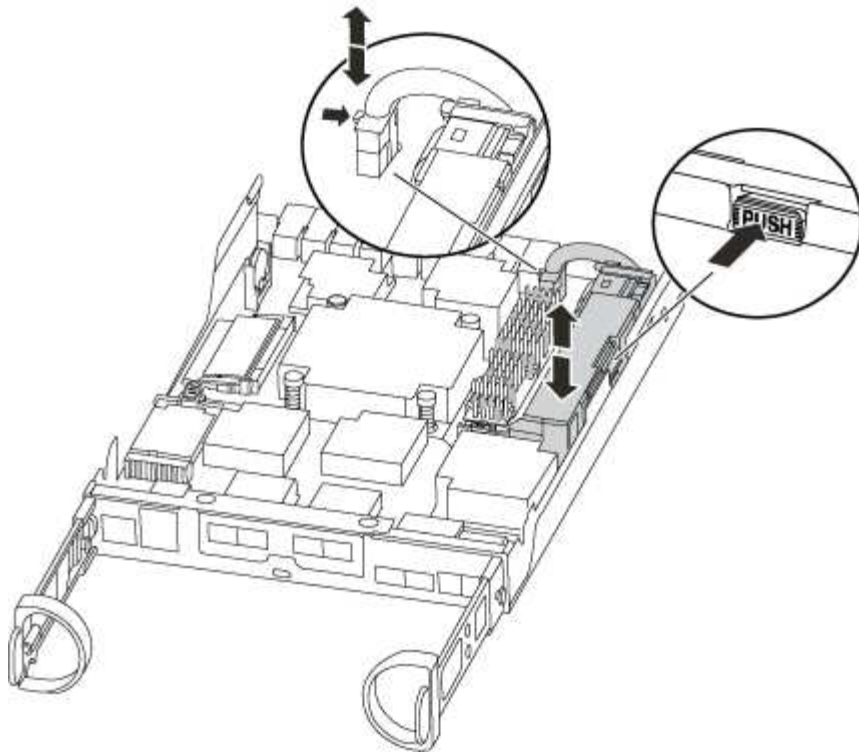

3. Locate the battery plug and squeeze the clip on the face of the battery plug to release the plug from the socket, and then unplug the battery cable from the socket.
4. Grasp the battery and press the blue locking tab marked PUSH, and then lift the battery out of the holder and controller module.
5. Move the battery to the replacement controller module.
6. Loop the battery cable around the cable channel on the side of the battery holder.
7. Position the battery pack by aligning the battery holder key ribs to the “V” notches on the sheet metal side wall.
8. Slide the battery pack down along the sheet metal side wall until the support tabs on the side wall hook into the slots on the battery pack, and the battery pack latch engages and clicks into the opening on the side wall.

### **Step 3: Move the boot media**

You must locate the boot media and follow the directions to remove it from the old controller module and insert it in the new controller module.

1. Locate the boot media using the following illustration or the FRU map on the controller module:

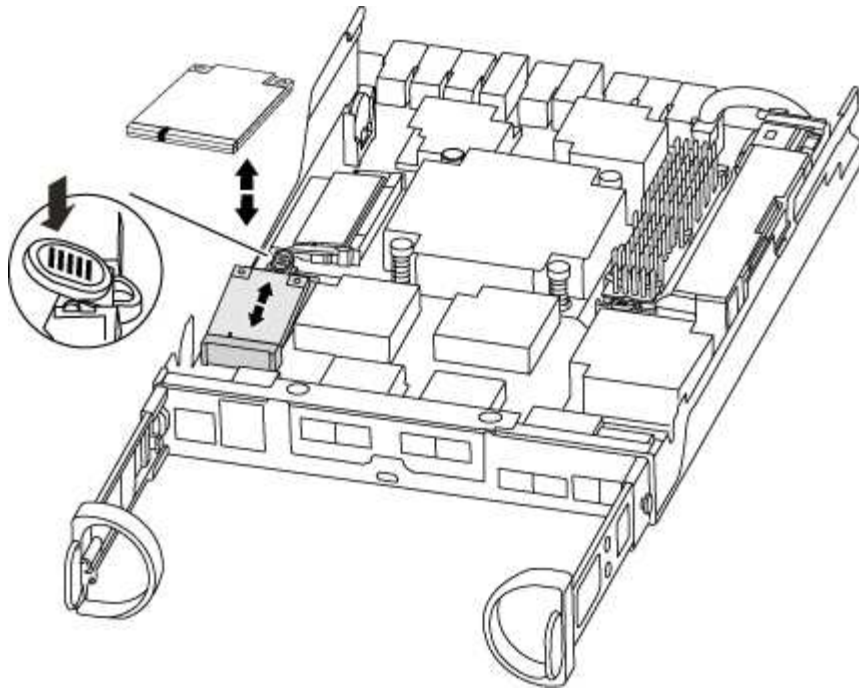

2. Press the blue button on the boot media housing to release the boot media from its housing, and then gently pull it straight out of the boot media socket.



Do not twist or pull the boot media straight up, because this could damage the socket or the boot media.

3. Move the boot media to the new controller module, align the edges of the boot media with the socket housing, and then gently push it into the socket.
4. Check the boot media to make sure that it is seated squarely and completely in the socket.

If necessary, remove the boot media and reseal it into the socket.

5. Push the boot media down to engage the locking button on the boot media housing.

#### Step 4: Move the DIMMs

To move the DIMMs, you must follow the directions to locate and move them from the old controller module into the replacement controller module.

You must have the new controller module ready so that you can move the DIMMs directly from the impaired controller module to the corresponding slots in the replacement controller module.

1. Locate the DIMMs on your controller module.
2. Note the orientation of the DIMM in the socket so that you can insert the DIMM in the replacement controller module in the proper orientation.
3. Eject the DIMM from its slot by slowly pushing apart the two DIMM ejector tabs on either side of the DIMM, and then slide the DIMM out of the slot.



Carefully hold the DIMM by the edges to avoid pressure on the components on the DIMM circuit board.

The number and placement of system DIMMs depends on the model of your system.

The following illustration shows the location of system DIMMs:

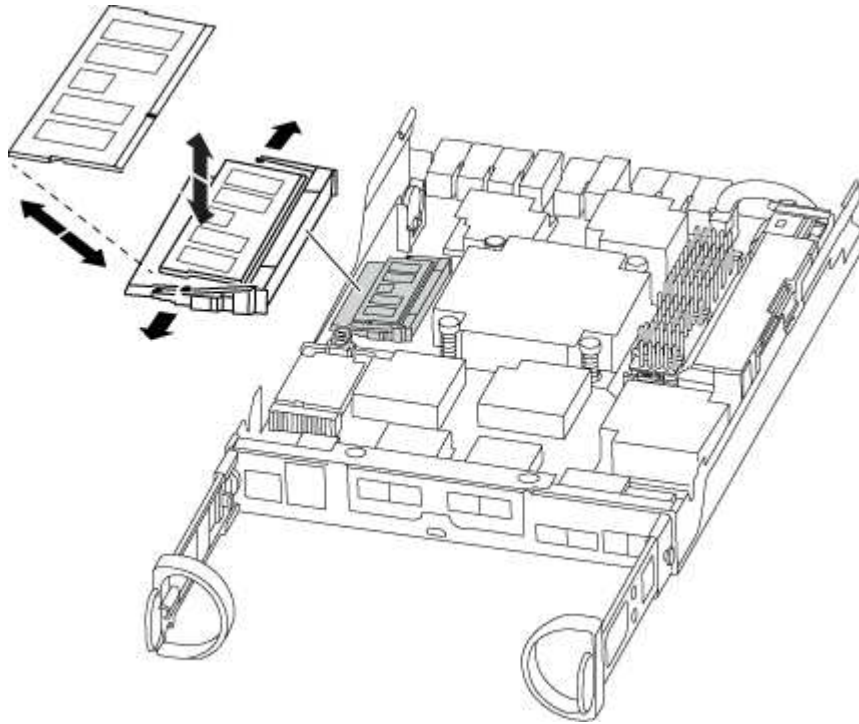

4. Repeat these steps to remove additional DIMMs as needed.
5. Verify that the NVMEM battery is not plugged into the new controller module.
6. Locate the slot where you are installing the DIMM.
7. Make sure that the DIMM ejector tabs on the connector are in the open position, and then insert the DIMM squarely into the slot.

The DIMM fits tightly in the slot, but should go in easily. If not, realign the DIMM with the slot and reinsert it.



Visually inspect the DIMM to verify that it is evenly aligned and fully inserted into the slot.

8. Repeat these steps for the remaining DIMMs.
9. Locate the NVMEM battery plug socket, and then squeeze the clip on the face of the battery cable plug to insert it into the socket.

Make sure that the plug locks down onto the controller module.

### **Step 5: Move a caching module, if present**

If your AFF A220 or FAS2700 system has a caching module, you need to move the caching module from the old controller module to the replacement controller module. The caching module is referred to as the “M.2 PCIe card” on the controller module label.

You must have the new controller module ready so that you can move the caching module directly from the old controller module to the corresponding slot in the new one. All other components in the storage system must be functioning properly; if not, you must contact technical support.

1. Locate the caching module at the rear of the controller module and remove it.

- a. Press the release tab.
- b. Remove the heatsink.

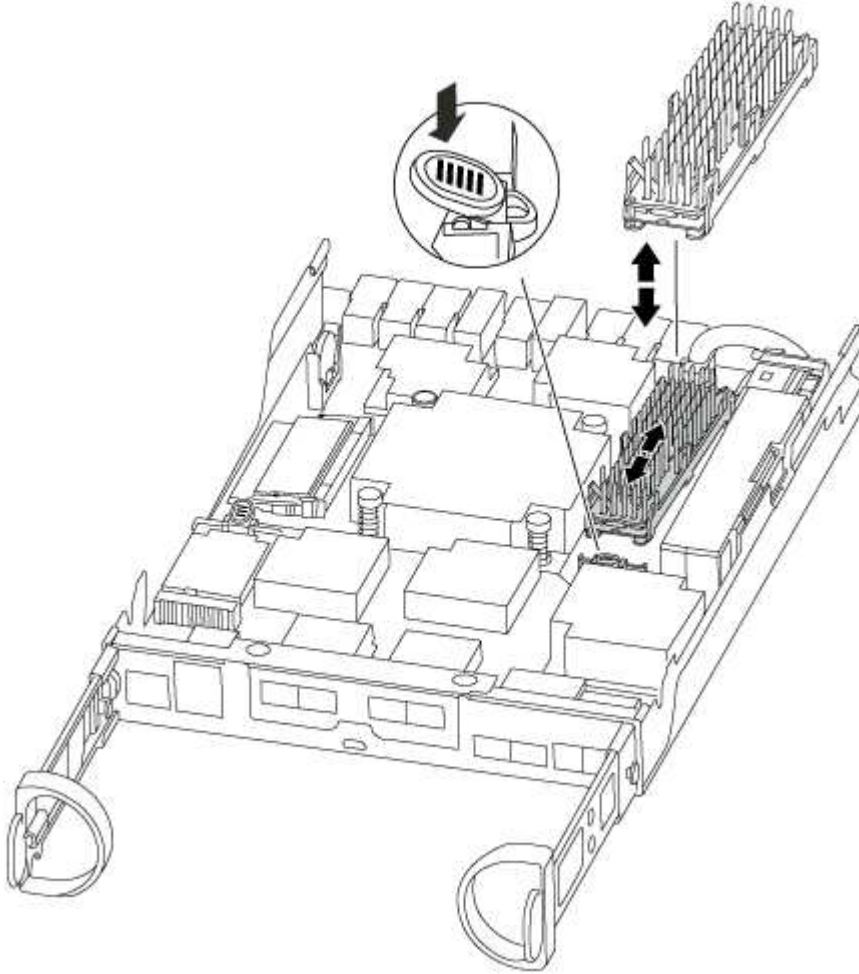

2. Gently pull the caching module straight out of the housing.
3. Move the caching module to the new controller module, and then align the edges of the caching module with the socket housing and gently push it into the socket.
4. Verify that the caching module is seated squarely and completely in the socket.

If necessary, remove the caching module and reseat it into the socket.

5. Reseat and push the heatsink down to engage the locking button on the caching module housing.
6. Close the controller module cover, as needed.

### Step 6: Install the controller

After you install the components from the old controller module into the new controller module, you must install the new controller module into the system chassis and boot the operating system.

For HA pairs with two controller modules in the same chassis, the sequence in which you install the controller module is especially important because it attempts to reboot as soon as you completely seat it in the chassis.



The system might update system firmware when it boots. Do not abort this process. The procedure requires you to interrupt the boot process, which you can typically do at any time after prompted to do so. However, if the system updates the system firmware when it boots, you must wait until after the update is complete before interrupting the boot process.

1. If you are not already grounded, properly ground yourself.
2. If you have not already done so, replace the cover on the controller module.
3. Align the end of the controller module with the opening in the chassis, and then gently push the controller module halfway into the system.





Do not completely insert the controller module in the chassis until instructed to do so.



4. Cable the management and console ports only, so that you can access the system to perform the tasks in the following sections.



You will connect the rest of the cables to the controller module later in this procedure.

5. Complete the reinstallation of the controller module:

If your system is in...	Then perform these steps...
An HA pair	<p>The controller module begins to boot as soon as it is fully seated in the chassis. Be prepared to interrupt the boot process.</p> <ol style="list-style-type: none"> <li>a. With the cam handle in the open position, firmly push the controller module in until it meets the midplane and is fully seated, and then close the cam handle to the locked position.</li> </ol> <div style="border-left: 1px solid #ccc; padding-left: 10px; margin: 10px 0;">  Do not use excessive force when sliding the controller module into the chassis; you might damage the connectors. </div> <p>The controller begins to boot as soon as it is seated in the chassis.</p> <ol style="list-style-type: none"> <li>b. If you have not already done so, reinstall the cable management device.</li> <li>c. Bind the cables to the cable management device with the hook and loop strap.</li> <li>d. Interrupt the boot process <b>only</b> after determining the correct timing: <p>You must look for an Automatic firmware update console message. If the update message appears, do not press <code>Ctrl-C</code> to interrupt the boot process until after you see a message confirming that the update is complete.</p> <p>Only press <code>Ctrl-C</code> when you see the message <code>Press Ctrl-C for Boot Menu</code>.</p> <div style="border-left: 1px solid #ccc; padding-left: 10px; margin: 10px 0;">  If the firmware update is aborted, the boot process exits to the LOADER prompt. You must run the <code>update_flash</code> command and then exit LOADER and boot to Maintenance mode by pressing <code>Ctrl-C</code> when you see <code>Starting AUTOBOOT press Ctrl-C to abort</code>. </div> <p>If you miss the prompt and the controller module boots to ONTAP, enter <code>halt</code>, and then at the LOADER prompt enter <code>boot_ontap</code>, press <code>Ctrl-C</code> when prompted, and then boot to Maintenance mode.</p> </li> <li>e. Select the option to boot to Maintenance mode from the displayed menu.</li> </ol>

If your system is in...	Then perform these steps...
A stand-alone configuration	<p>a. With the cam handle in the open position, firmly push the controller module in until it meets the midplane and is fully seated, and then close the cam handle to the locked position.</p> <div style="border-left: 1px solid #ccc; padding-left: 10px; margin: 10px 0;">  Do not use excessive force when sliding the controller module into the chassis to avoid damaging the connectors. </div> <p>b. If you have not already done so, reinstall the cable management device.</p> <p>c. Bind the cables to the cable management device with the hook and loop strap.</p> <p>d. Reconnect the power cables to the power supplies and to the power sources, and then turn on the power to start the boot process.</p> <p>e. Interrupt the boot process <b>only</b> after determining the correct timing:</p> <p>You must look for an Automatic firmware update console message. If the update message appears, do not press <code>Ctrl-C</code> to interrupt the boot process until after you see a message confirming that the update is complete.</p> <p>Only press <code>Ctrl-C</code> after you see the <code>Press Ctrl-C for Boot Menu</code> message.</p> <div style="border-left: 1px solid #ccc; padding-left: 10px; margin: 10px 0;">  If the firmware update is aborted, the boot process exits to the LOADER prompt. You must run the <code>update_flash</code> command and then exit LOADER and boot to Maintenance mode by pressing <code>Ctrl-C</code> when you see <code>Starting AUTOBOOT</code> press <code>Ctrl-C</code> to abort. </div> <p>If you miss the prompt and the controller module boots to ONTAP, enter <code>halt</code>, and then at the LOADER prompt enter <code>boot_ontap</code>, press <code>Ctrl-C</code> when prompted, and then boot to Maintenance mode.</p> <p>f. From the boot menu, select the option for Maintenance mode.</p>

**Important:** During the boot process, you might see the following prompts:

- A prompt warning of a system ID mismatch and asking to override the system ID.
- A prompt warning that when entering Maintenance mode in an HA configuration you must ensure that the healthy controller remains down.  
You can safely respond `y` to these prompts.

## Restore and verify the system configuration - ASA A150

After completing the hardware replacement and booting to Maintenance mode, you verify the low-level system configuration of the replacement controller and reconfigure system settings as necessary.

### Step 1: Set and verify system time after replacing the controller

You should check the time and date on the replacement controller module against the healthy controller module in an HA pair, or against a reliable time server in a stand-alone configuration. If the time and date do not match, you must reset them on the replacement controller module to prevent possible outages on clients due to time differences.

#### About this task

It is important that you apply the commands in the steps on the correct systems:

- The *replacement* node is the new node that replaced the impaired node as part of this procedure.
- The *healthy* node is the HA partner of the *replacement* node.

#### Steps

1. If the *replacement* node is not at the LOADER prompt, halt the system to the LOADER prompt.
2. On the *healthy* node, check the system time: `cluster date show`

The date and time are based on the configured timezone.

3. At the LOADER prompt, check the date and time on the *replacement* node: `show date`

The date and time are given in GMT.

4. If necessary, set the date in GMT on the replacement node: `set date mm/dd/yyyy`

5. If necessary, set the time in GMT on the replacement node: `set time hh:mm:ss`

6. At the LOADER prompt, confirm the date and time on the *replacement* node: `show date`

The date and time are given in GMT.

### Step 2: Verify and set the HA state of the controller module

You must verify the HA state of the controller module and, if necessary, update the state to match your system configuration.

1. In Maintenance mode from the new controller module, verify that all components display the same HA state: `ha-config show`

The HA state should be the same for all components.

2. If the displayed system state for the chassis does not match your system configuration:

- a. Set the HA state for the chassis: `ha-config modify chassis HA-state`

The value for HA-state can be one of the following:



- ha
- mcc
- mcc-2n
- mccip
- non-ha

b. Confirm that the setting has changed: `ha-config show`

## Recable the system and reassign disks - ASA A150

To complete the replacement procedure and restore your system to full operation, you must recable the storage, confirm disk reassignment, restore the NetApp Storage Encryption configuration (if necessary), and install licenses for the new controller. You must complete a series of tasks before restoring your system to full operation.

### Step 1: Recable the system

Recable the controller module's storage and network connections.

#### Steps

1. Recable the the controller module to storage and network connections.
2. Verify that the cabling is correct by using [Active IQ Config Advisor](#).
  - a. Download and install Config Advisor.
  - b. Enter the information for the target system, and then click Collect Data.
  - c. Click the Cabling tab, and then examine the output. Make sure that all disk shelves are displayed and all disks appear in the output, correcting any cabling issues you find.
  - d. Check other cabling by clicking the appropriate tab, and then examining the output from Config Advisor.

### Step 2: Reassign disks

If the storage system is in an HA pair, the system ID of the new controller module is automatically assigned to the disks when the giveback occurs at the end of the procedure. In a stand-alone system, you must manually reassign the ID to the disks.

You must use the correct procedure for your configuration:

Controller redundancy	Then use this procedure...
HA pair	<a href="#">Option 1: Verify the system ID change on an HA system</a>
Stand-alone	<a href="#">Option 2: Manually reassign the system ID on a stand-alone system in ONTAP</a>
Two-node MetroCluster configuration	<a href="#">Option 3: Manually reassign the system ID on systems in a two-node MetroCluster configuration</a>

## Option 1: Verify the system ID change on an HA system

You must confirm the system ID change when you boot the *replacement* controller and then verify that the change was implemented.

This procedure applies only to systems running ONTAP in an HA pair.

1. If the *replacement* controller is in Maintenance mode (showing the `*>` prompt, exit Maintenance mode and go to the LOADER prompt: `halt`
2. From the LOADER prompt on the *replacement* controller, boot the controller, entering `y` if you are prompted to override the system ID due to a system ID mismatch: `boot_ontap`
3. Wait until the `Waiting for giveback...` message is displayed on the *replacement* controller console and then, from the healthy controller, verify that the new partner system ID has been automatically assigned: `storage failover show`

In the command output, you should see a message that the system ID has changed on the impaired controller, showing the correct old and new IDs. In the following example, `node2` has undergone replacement and has a new system ID of `151759706`.

```
node1> `storage failover show`
```

Node	Partner	Takeover Possible	State Description
node1	node2	false	System ID changed on partner (Old: 151759755, New: 151759706), In takeover
node2	node1	-	Waiting for giveback (HA mailboxes)

4. From the healthy controller, verify that any coredumps are saved:
  - a. Change to the advanced privilege level: `set -privilege advanced`

You can respond `y` when prompted to continue into advanced mode. The advanced mode prompt appears (`*>`).
  - b. Save any coredumps: `system node run -node local-node-name partner savecore`
  - c. Wait for the `savecore` command to complete before issuing the giveback.

You can enter the following command to monitor the progress of the `savecore` command: `system node run -node local-node-name partner savecore -s`
  - d. Return to the admin privilege level: `set -privilege admin`
5. If your storage system has Storage or Volume Encryption configured, you must restore Storage or Volume Encryption functionality by using one of the following procedures, depending on whether you are using onboard or external key management:

- [Restore onboard key management encryption keys](#)
- [Restore external key management encryption keys](#)

6. Give back the controller:

- a. From the healthy controller, give back the replaced controller's storage: `storage failover giveback -ofnode replacement_node_name`

The *replacement* controller takes back its storage and completes booting.

If you are prompted to override the system ID due to a system ID mismatch, you should enter *y*.



If the giveback is vetoed, you can consider overriding the vetoes.

[Find the High-Availability Configuration content for your version of ONTAP 9](#)

- b. After the giveback has been completed, confirm that the HA pair is healthy and that takeover is possible: `storage failover show`

The output from the `storage failover show` command should not include the System ID changed on partner message.

7. Verify that the disks were assigned correctly: `storage disk show -ownership`

The disks belonging to the *replacement* controller should show the new system ID. In the following example, the disks owned by node1 now show the new system ID, 1873775277:

```
node1> `storage disk show -ownership`

Disk Aggregate Home Owner DR Home Home ID Owner ID DR Home ID
Reserver Pool
-----
-----
-----
1.0.0 aggr0_1 node1 node1 - 1873775277 1873775277 -
1873775277 Pool0
1.0.1 aggr0_1 node1 node1 1873775277 1873775277 -
1873775277 Pool0
.
.
.
```

**Option 2: Manually reassign the system ID on a stand-alone system in ONTAP**

In a stand-alone system, you must manually reassign disks to the new controller's system ID before you return the system to normal operating condition.



**About this task**

This procedure applies only to systems that are in a stand-alone configuration.

## Steps

1. If you have not already done so, reboot the *replacement* node, interrupt the boot process by pressing Ctrl-C, and then select the option to boot to Maintenance mode from the displayed menu.
2. You must enter Y when prompted to override the system ID due to a system ID mismatch.
3. View the system IDs: `disk show -a`
4. You should make a note of the old system ID, which is displayed as part of the disk owner column.

The following example shows the old system ID of 118073209:

```
*> disk show -a
Local System ID: 118065481

  DISK          OWNER          POOL  SERIAL NUMBER  HOME
  -----
disk_name      system-1  (118073209)  Pool0  J8XJE9LC      system-1
(118073209)
disk_name      system-1  (118073209)  Pool0  J8Y478RC      system-1
(118073209)
.
.
.
```

5. Reassign disk ownership by using the system ID information obtained from the disk show command: `disk reassign -s old system ID disk reassign -s 118073209`
6. Verify that the disks were assigned correctly: `disk show -a`

The disks belonging to the replacement node should show the new system ID. The following example now show the disks owned by system-1 the new system ID, 118065481:

```
*> disk show -a
Local System ID: 118065481

  DISK          OWNER          POOL  SERIAL NUMBER  HOME
  -----
disk_name      system-1  (118065481)  Pool0  J8Y0TDZC      system-1
(118065481)
disk_name      system-1  (118065481)  Pool0  J8Y0TDZC      system-1
(118065481)
.
.
.
```

7. If your storage system has Storage or Volume Encryption configured, you must restore Storage or Volume Encryption functionality by using one of the following procedures, depending on whether you are using onboard or external key management:

- [Restore onboard key management encryption keys](#)
- [Restore external key management encryption keys](#)

8. Boot the node: `boot_ontap`

### Option 3: Manually reassign the system ID on systems in a two-node MetroCluster configuration

In a two-node MetroCluster configuration running ONTAP, you must manually reassign disks to the new controller's system ID before you return the system to normal operating condition.

#### About this task

This procedure applies only to systems in a two-node MetroCluster configuration running ONTAP.

You must be sure to issue the commands in this procedure on the correct node:

- The *impaired* node is the node on which you are performing maintenance.
- The *replacement* node is the new node that replaced the impaired node as part of this procedure.
- The *healthy* node is the DR partner of the impaired node.

#### Steps

1. If you have not already done so, reboot the *replacement* node, interrupt the boot process by entering `Ctrl-C`, and then select the option to boot to Maintenance mode from the displayed menu.

You must enter `Y` when prompted to override the system ID due to a system ID mismatch.

2. View the old system IDs from the healthy node: ``metrocluster node show -fields node-systemid,dr-partner-systemid``

In this example, the `Node_B_1` is the old node, with the old system ID of 118073209:

```
dr-group-id cluster          node          node-systemid dr-
partner-systemid
-----
1          Cluster_A          Node_A_1          536872914
118073209
1          Cluster_B          Node_B_1          118073209
536872914
2 entries were displayed.
```

3. View the new system ID at the Maintenance mode prompt on the impaired node: `disk show`

In this example, the new system ID is 118065481:

```
Local System ID: 118065481
...
...
```

4. Reassign disk ownership (for FAS systems) or LUN ownership (for FlexArray systems), by using the system ID information obtained from the disk show command: `disk reassign -s old system ID`

In the case of the preceding example, the command is: `disk reassign -s 118073209`

You can respond `Y` when prompted to continue.

5. Verify that the disks (or FlexArray LUNs) were assigned correctly: `disk show -a`

Verify that the disks belonging to the *replacement* node show the new system ID for the *replacement* node. In the following example, the disks owned by system-1 now show the new system ID, 118065481:

```
*> disk show -a
Local System ID: 118065481

  DISK          OWNER          POOL  SERIAL NUMBER  HOME
  -----          -
disk_name      system-1  (118065481) Pool0  J8Y0TDZC      system-1
(118065481)
disk_name      system-1  (118065481) Pool0  J8Y09DXC      system-1
(118065481)
.
.
.
```

6. From the healthy node, verify that any coredumps are saved:

- a. Change to the advanced privilege level: `set -privilege advanced`

You can respond `Y` when prompted to continue into advanced mode. The advanced mode prompt appears (`*>`).

- b. Verify that the coredumps are saved: `system node run -node local-node-name partner savecore`

If the command output indicates that `savecore` is in progress, wait for `savecore` to complete before issuing the giveback. You can monitor the progress of the `savecore` using the `system node run -node local-node-name partner savecore -s command.</info>`.

- c. Return to the admin privilege level: `set -privilege admin`

7. If the *replacement* node is in Maintenance mode (showing the `*>` prompt), exit Maintenance mode and go to the LOADER prompt: `halt`
8. Boot the *replacement* node: `boot_ontap`
9. After the *replacement* node has fully booted, perform a switchback: `metrocluster switchback`
10. Verify the MetroCluster configuration: `metrocluster node show - fields configuration-state`

```

node1_siteA::> metrocluster node show -fields configuration-state

dr-group-id          cluster node          configuration-state
-----
-----
1 node1_siteA        node1mcc-001         configured
1 node1_siteA        node1mcc-002         configured
1 node1_siteB        node1mcc-003         configured
1 node1_siteB        node1mcc-004         configured

4 entries were displayed.

```

11. Verify the operation of the MetroCluster configuration in Data ONTAP:

- a. Check for any health alerts on both clusters: `system health alert show`
- b. Confirm that the MetroCluster is configured and in normal mode: `metrocluster show`
- c. Perform a MetroCluster check: `metrocluster check run`
- d. Display the results of the MetroCluster check: `metrocluster check show`
- e. Run Config Advisor. Go to the Config Advisor page on the NetApp Support Site at [support.netapp.com/NOW/download/tools/config\\_advisor/](http://support.netapp.com/NOW/download/tools/config_advisor/).

After running Config Advisor, review the tool's output and follow the recommendations in the output to address any issues discovered.

12. Simulate a switchover operation:

- a. From any node's prompt, change to the advanced privilege level: `set -privilege advanced`

You need to respond with `y` when prompted to continue into advanced mode and see the advanced mode prompt (`*>`).

- b. Perform the switchover operation with the `-simulate` parameter: `metrocluster switchover -simulate`
- c. Return to the admin privilege level: `set -privilege admin`

### Complete system restoration - ASA A150

To restore your system to full operation, you must restore the NetApp Storage Encryption configuration (if necessary), and install licenses for the new controller, and return the failed part to NetApp, as described in the RMA instructions shipped with the kit.

#### Step 1: Install licenses for the replacement controller in ONTAP

You must install new licenses for the *replacement* node if the impaired node was using ONTAP features that require a standard (node-locked) license. For features with standard licenses, each node in the cluster should have its own key for the feature.

#### About this task

Until you install license keys, features requiring standard licenses continue to be available to the *replacement* node. However, if the impaired node was the only node in the cluster with a license for the feature, no configuration changes to the feature are allowed. Also, using unlicensed features on the node might put you out of compliance with your license agreement, so you should install the replacement license key or keys on the *replacement* node as soon as possible.

### Before you begin

The licenses keys must be in the 28-character format.

You have a 90-day grace period in which to install the license keys. After the grace period, all old licenses are invalidated. After a valid license key is installed, you have 24 hours to install all of the keys before the grace period ends.

### Steps

1. If you need new license keys, obtain replacement license keys on the [NetApp Support Site](#) in the My Support section under Software licenses.



The new license keys that you require are automatically generated and sent to the email address on file. If you fail to receive the email with the license keys within 30 days, you should contact technical support.

2. Install each license key: `system license add -license-code license-key, license-key...`
3. Remove the old licenses, if desired:
  - a. Check for unused licenses: `license clean-up -unused -simulate`
  - b. If the list looks correct, remove the unused licenses: `license clean-up -unused`

### Step 2: Verify LIFs and register the serial number

Before returning the *replacement* node to service, you should verify that the LIFs are on their home ports, and register the serial number of the *replacement* node if AutoSupport is enabled, and reset automatic giveback.

### Steps

1. Verify that the logical interfaces are reporting to their home server and ports: `network interface show -is-home false`  
  
If any LIFs are listed as false, revert them to their home ports: `network interface revert -vserver * -lif *`
2. Register the system serial number with NetApp Support.
  - If AutoSupport is enabled, send an AutoSupport message to register the serial number.
  - If AutoSupport is not enabled, call [NetApp Support](#) to register the serial number.
3. If an AutoSupport maintenance window was triggered, end it by using the `system node autosupport invoke -node * -type all -message MAINT=END` command.
4. If automatic giveback was disabled, reenable it: `storage failover modify -node local -auto-giveback true`

### Step 3: Switch back aggregates in a two-node MetroCluster configuration

After you have completed the FRU replacement in a two-node MetroCluster configuration, you can perform the



MetroCluster switchback operation. This returns the configuration to its normal operating state, with the sync-source storage virtual machines (SVMs) on the formerly impaired site now active and serving data from the local disk pools.

This task only applies to two-node MetroCluster configurations.

### Steps

1. Verify that all nodes are in the enabled state: `metrocluster node show`

```
cluster_B::> metrocluster node show

DR                               Configuration  DR
Group Cluster Node              State          Mirroring Mode
-----
1      cluster_A
      controller_A_1 configured      enabled      heal roots
completed
      cluster_B
      controller_B_1 configured      enabled      waiting for
switchback recovery
2 entries were displayed.
```

2. Verify that resynchronization is complete on all SVMs: `metrocluster vserver show`
3. Verify that any automatic LIF migrations being performed by the healing operations were completed successfully: `metrocluster check lif show`
4. Perform the switchback by using the `metrocluster switchback` command from any node in the surviving cluster.
5. Verify that the switchback operation has completed: `metrocluster show`

The switchback operation is still running when a cluster is in the `waiting-for-switchback` state:

```
cluster_B::> metrocluster show

Cluster          Configuration State      Mode
-----
Local: cluster_B configured      switchover
Remote: cluster_A configured      waiting-for-switchback
```

The switchback operation is complete when the clusters are in the `normal` state.:

```
cluster_B::> metrocluster show
Cluster          Configuration State      Mode
-----
Local: cluster_B configured      normal
Remote: cluster_A configured      normal
```

If a switchback is taking a long time to finish, you can check on the status of in-progress baselines by using the `metrocluster config-replication resync-status show` command.

6. Reestablish any SnapMirror or SnapVault configurations.

#### Step 4: Return the failed part to NetApp

Return the failed part to NetApp, as described in the RMA instructions shipped with the kit. See the [Part Return and Replacements](#) page for further information.

#### Replace the DIMM - ASA A150

You must replace a DIMM in the controller module when your system registers an increasing number of correctable error correction codes (ECC); failure to do so causes a system panic.

All other components in the system must be functioning properly; if not, you must contact technical support.

You must replace the failed component with a replacement FRU component you received from your provider.

#### Step 1: Shut down the impaired controller

To shut down the impaired controller, you must determine the status of the controller and, if necessary, take over the controller so that the healthy controller continues to serve data from the impaired controller storage.

#### About this task

- If you have a SAN system, you must have checked event messages (`cluster kernel-service show`) for the impaired controller SCSI blade. The `cluster kernel-service show` command (from `priv advanced mode`) displays the node name, quorum status of that node, availability status of that node, and operational status of that node.

Each SCSI-blade process should be in quorum with the other nodes in the cluster. Any issues must be resolved before you proceed with the replacement.

- If you have a cluster with more than two nodes, it must be in quorum. If the cluster is not in quorum or a healthy controller shows false for eligibility and health, you must correct the issue before shutting down the impaired controller; see [Synchronize a node with the cluster](#).

#### Steps

1. If AutoSupport is enabled, suppress automatic case creation by invoking an AutoSupport message:
 

```
system node autosupport invoke -node * -type all -message MAINT=<# of hours>h
```

The following AutoSupport message suppresses automatic case creation for two hours: `cluster1:>`

```
system node autosupport invoke -node * -type all -message MAINT=2h
```

2. Disable automatic giveback from the console of the healthy controller: `storage failover modify -node local -auto-giveback false`



When you see *Do you want to disable auto-giveback?*, enter *y*.

3. Take the impaired controller to the LOADER prompt:

If the impaired controller is displaying...	Then...
The LOADER prompt	Go to the next step.
Waiting for giveback...	Press Ctrl-C, and then respond <i>y</i> when prompted.
System prompt or password prompt	Take over or halt the impaired controller from the healthy controller: <code>storage failover takeover -ofnode impaired_node_name</code>  When the impaired controller shows Waiting for giveback..., press Ctrl-C, and then respond <i>y</i> .

4. If the system has only one controller module in the chassis, turn off the power supplies, and then unplug the impaired controller's power cords from the power source.

## Step 2: Remove controller module

To access components inside the controller, you must first remove the controller module from the system and then remove the cover on the controller module.

### Steps

1. If you are not already grounded, properly ground yourself.
2. Loosen the hook and loop strap binding the cables to the cable management device, and then unplug the system cables and SFPs (if needed) from the controller module, keeping track of where the cables were connected.

Leave the cables in the cable management device so that when you reinstall the cable management device, the cables are organized.

3. Remove and set aside the cable management devices from the left and right sides of the controller module.

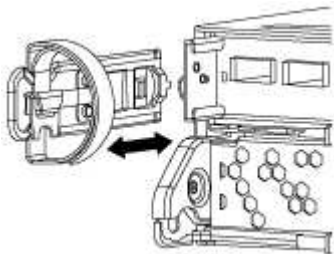

4. Squeeze the latch on the cam handle until it releases, open the cam handle fully to release the controller module from the midplane, and then, using two hands, pull the controller module out of the chassis.

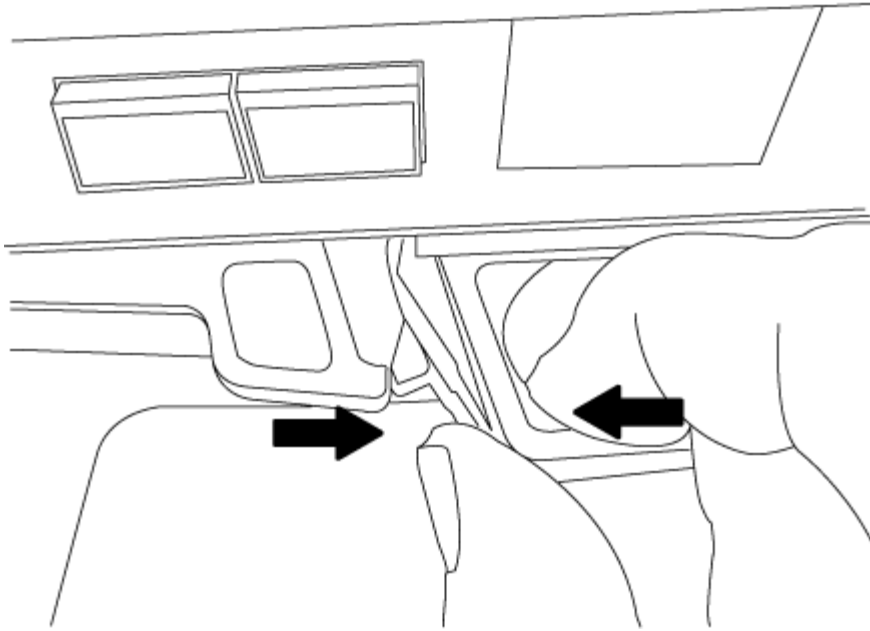

5. Turn the controller module over and place it on a flat, stable surface.
6. Open the cover by sliding in the blue tabs to release the cover, and then swing the cover up and open.

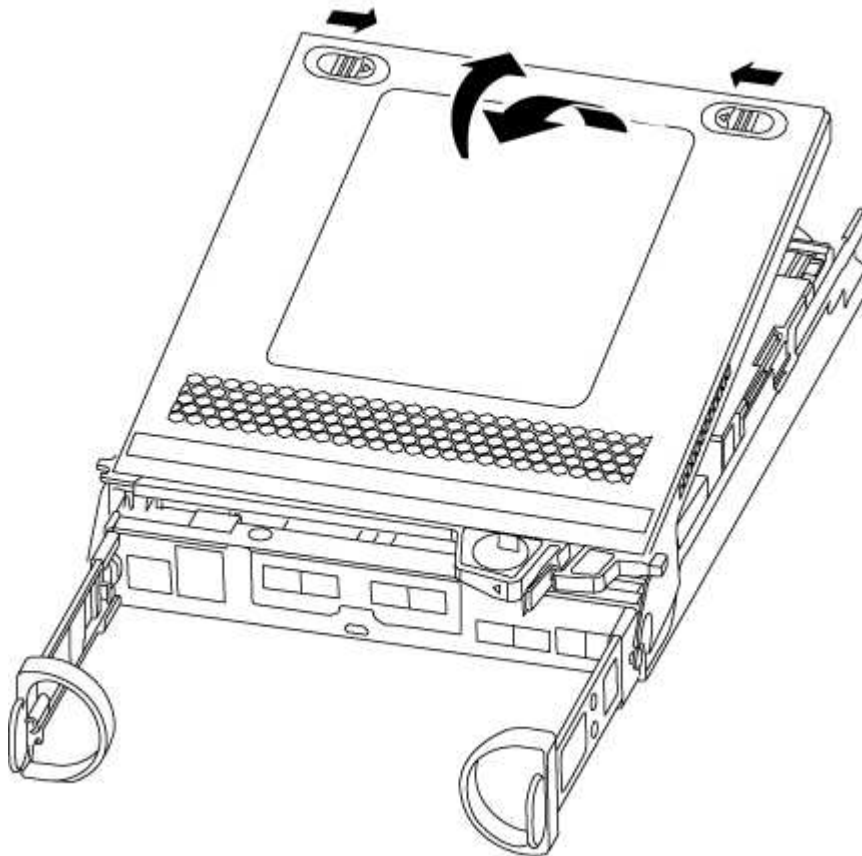

### Step 3: Replace the DIMMs

To replace the DIMMs, locate them inside the controller and follow the specific sequence of steps.

If you are replacing a DIMM, you need to remove it after you have unplugged the NVMEM battery from the controller module.

## Steps

1. If you are not already grounded, properly ground yourself.
2. Check the NVMEM LED on the back of controller module.

You must perform a clean system shutdown before replacing system components to avoid losing unwritten data in the nonvolatile memory (NVMEM). The LED is located on the back of the controller module. Look for the following icon:



3. If the NVMEM LED is not flashing, there is no content in the NVMEM; you can skip the following steps and proceed to the next task in this procedure.
4. If the NVMEM LED is flashing, there is data in the NVMEM and you must disconnect the battery to clear the memory:
  - a. Locate the battery, press the clip on the face of the battery plug to release the lock clip from the plug socket, and then unplug the battery cable from the socket.

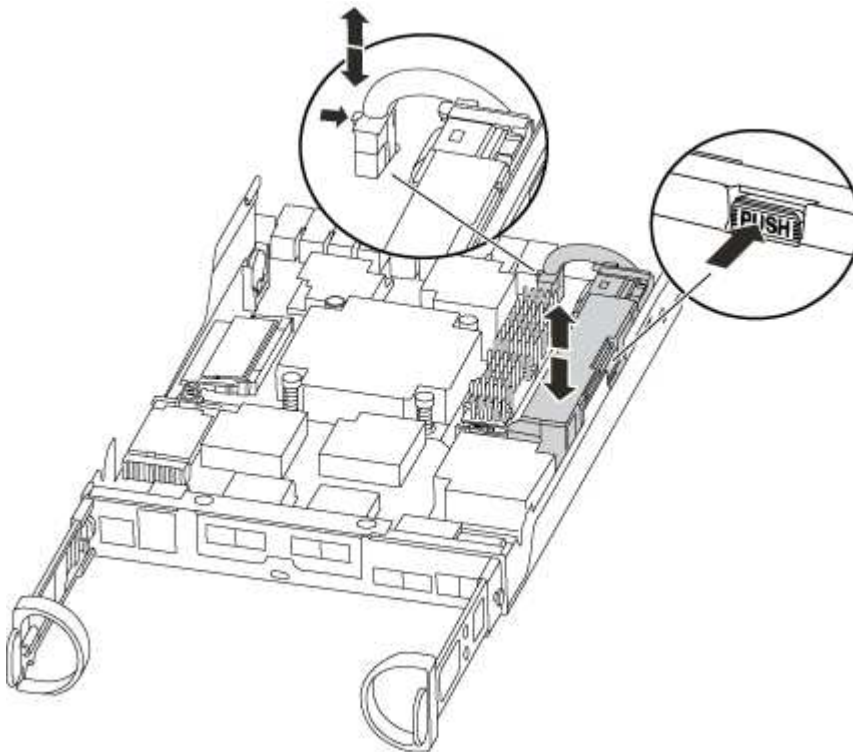

- b. Confirm that the NVMEM LED is no longer lit.
  - c. Reconnect the battery connector.
5. Return to [Step 3: Replace the DIMMs](#) of this procedure to recheck the NVMEM LED.
  6. Locate the DIMMs on your controller module.
  7. Note the orientation of the DIMM in the socket so that you can insert the replacement DIMM in the proper

orientation.

- Eject the DIMM from its slot by slowly pushing apart the two DIMM ejector tabs on either side of the DIMM, and then slide the DIMM out of the slot.



Carefully hold the DIMM by the edges to avoid pressure on the components on the DIMM circuit board.

The number and placement of system DIMMs depends on the model of your system.

The following illustration shows the location of system DIMMs:

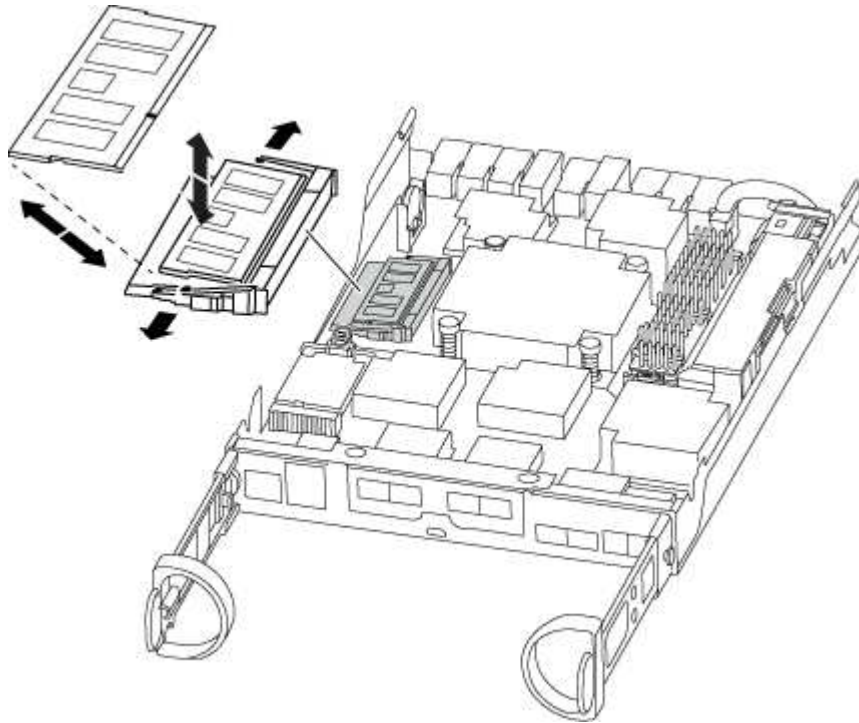

- Remove the replacement DIMM from the antistatic shipping bag, hold the DIMM by the corners, and align it to the slot.

The notch among the pins on the DIMM should line up with the tab in the socket.

- Make sure that the DIMM ejector tabs on the connector are in the open position, and then insert the DIMM squarely into the slot.

The DIMM fits tightly in the slot, but should go in easily. If not, realign the DIMM with the slot and reinsert it.



Visually inspect the DIMM to verify that it is evenly aligned and fully inserted into the slot.

- Push carefully, but firmly, on the top edge of the DIMM until the ejector tabs snap into place over the notches at the ends of the DIMM.
- Locate the NVMEM battery plug socket, and then squeeze the clip on the face of the battery cable plug to insert it into the socket.

Make sure that the plug locks down onto the controller module.

- Close the controller module cover.

## Step 4: Reinstall the controller module

After you replace components in the controller module, reinstall it into the chassis.

### Steps

1. If you are not already grounded, properly ground yourself.
2. If you have not already done so, replace the cover on the controller module.
3. Align the end of the controller module with the opening in the chassis, and then gently push the controller module halfway into the system.





Do not completely insert the controller module in the chassis until instructed to do so.

4. Recable the system, as needed.

If you removed the media converters (QSFPs or SFPs), remember to reinstall them if you are using fiber optic cables.

5. Complete the reinstallation of the controller module:

If your system is in...	Then perform these steps...
An HA pair	<p>The controller module begins to boot as soon as it is fully seated in the chassis.</p> <ol style="list-style-type: none"><li>a. With the cam handle in the open position, firmly push the controller module in until it meets the midplane and is fully seated, and then close the cam handle to the locked position.</li></ol> <p> Do not use excessive force when sliding the controller module into the chassis to avoid damaging the connectors.</p> <p>The controller begins to boot as soon as it is seated in the chassis.</p> <ol style="list-style-type: none"><li>b. If you have not already done so, reinstall the cable management device.</li><li>c. Bind the cables to the cable management device with the hook and loop strap.</li></ol>

If your system is in...	Then perform these steps...
A stand-alone configuration	<p>a. With the cam handle in the open position, firmly push the controller module in until it meets the midplane and is fully seated, and then close the cam handle to the locked position.</p> <div style="border: 1px solid gray; padding: 5px; margin: 10px 0;">  Do not use excessive force when sliding the controller module into the chassis to avoid damaging the connectors. </div> <p>b. If you have not already done so, reinstall the cable management device.</p> <p>c. Bind the cables to the cable management device with the hook and loop strap.</p> <p>d. Reconnect the power cables to the power supplies and to the power sources, then turn on the power to start the boot process.</p>

### Step 5: Switch back aggregates in a two-node MetroCluster configuration

After you have completed the FRU replacement in a two-node MetroCluster configuration, you can perform the MetroCluster switchback operation. This returns the configuration to its normal operating state, with the sync-source storage virtual machines (SVMs) on the formerly impaired site now active and serving data from the local disk pools.

This task only applies to two-node MetroCluster configurations.

#### Steps

1. Verify that all nodes are in the enabled state: `metrocluster node show`

```
cluster_B::> metrocluster node show

DR                               Configuration  DR
Group Cluster Node              State          Mirroring Mode
-----
1      cluster_A
      controller_A_1 configured    enabled    heal roots
completed
      cluster_B
      controller_B_1 configured    enabled    waiting for
switchback recovery
2 entries were displayed.
```

2. Verify that resynchronization is complete on all SVMs: `metrocluster vserver show`
3. Verify that any automatic LIF migrations being performed by the healing operations were completed successfully: `metrocluster check lif show`



4. Perform the switchback by using the `metrocluster switchback` command from any node in the surviving cluster.
5. Verify that the switchback operation has completed: `metrocluster show`

The switchback operation is still running when a cluster is in the `waiting-for-switchback` state:

```
cluster_B::> metrocluster show
Cluster           Configuration State      Mode
-----
Local: cluster_B configured      switchover
Remote: cluster_A configured     waiting-for-switchback
```

The switchback operation is complete when the clusters are in the `normal` state.:

```
cluster_B::> metrocluster show
Cluster           Configuration State      Mode
-----
Local: cluster_B configured      normal
Remote: cluster_A configured     normal
```

If a switchback is taking a long time to finish, you can check on the status of in-progress baselines by using the `metrocluster config-replication resync-status show` command.

6. Reestablish any SnapMirror or SnapVault configurations.

### Step 6: Return the failed part to NetApp

Return the failed part to NetApp, as described in the RMA instructions shipped with the kit. See the [Part Return and Replacements](#) page for further information.

#### Replace the SSD drive or HDD Drive - ASA 150

You can replace a failed drive nondisruptively while I/O is in progress. The procedure for replacing an SSD is meant for non-spinning drives and the procedure for replacing an HDD is meant for spinning drives.

When a drive fails, the platform logs a warning message to the system console indicating which drive has failed. In addition, both the fault LED on the operator display panel and the fault LED on the failed drive are illuminated.

#### Before you begin

- Follow best practice and install the current version of the Disk Qualification Package (DQP) before replacing a drive.
- Identify the failed drive by running the `storage disk show -broken` command from the system console.

The failed drive appears in the list of failed drives. If it does not, you should wait, and then run the

command again.



Depending on the type and capacity, it can take up to several hours for the drive to appear in the list of failed drives.

- Determine whether SED authentication is enabled.

How you replace the drive depends on how the drive is being used. If SED authentication is enabled, you must use the SED replacement instructions in the [ONTAP 9 NetApp Encryption Power Guide](#). These Instructions describe additional steps you must perform before and after replacing an SED.

- Make sure the replacement drive is supported by your platform. See the [NetApp Hardware Universe](#).
- Make sure all other components in the system are functioning properly; if not, you must contact technical support.

#### **About this task**

- Drive firmware is automatically updated (nondisruptively) on new drives that have non current firmware versions.
- When replacing a drive, you must wait one minute between the removal of the failed drive and the insertion of the replacement drive to allow the storage system to recognize the existence of the new drive.

## Option 1: Replace SSD

### Steps

1. If you want to manually assign drive ownership for the replacement drive, you need to disable automatic drive assignment replacement drive, if it is enabled



You manually assign drive ownership and then reenables automatic drive assignment later in this procedure.

- a. Verify whether automatic drive assignment is enabled: `storage disk option show`

You can enter the command on either controller module.

If automatic drive assignment is enabled, the output shows `on` in the “Auto Assign” column (for each controller module).

- b. If automatic drive assignment is enabled, disable it: `storage disk option modify -node node_name -autoassign off`

You must disable automatic drive assignment on both controller modules.

2. Properly ground yourself.
3. Physically identify the failed drive.

When a drive fails, the system logs a warning message to the system console indicating which drive failed. Additionally, the attention (amber) LED on the drive shelf operator display panel and the failed drive illuminate.



The activity (green) LED on a failed drive can be illuminated (solid), which indicates that the drive has power, but should not be blinking, which indicates I/O activity. A failed drive has no I/O activity.

4. Remove the failed drive:
  - a. Press the release button on the drive face to open the cam handle.
  - b. Slide the drive out of the shelf using the cam handle and supporting the drive with your other hand.

5. Wait a minimum of 70 seconds before inserting the replacement drive.

This allows the system to recognize that a drive was removed.

6. Insert the replacement drive:
  - a. With the cam handle in the open position, use both hands to insert the replacement drive.
  - b. Push until the drive stops.
  - c. Close the cam handle so that the drive is fully seated into the midplane and the handle clicks into place.

Be sure to close the cam handle slowly so that it aligns correctly with the face of the drive.

7. Verify that the drive’s activity (green) LED is illuminated.

When the drive's activity LED is solid, it means that the drive has power. When the drive's activity LED is blinking, it means that the drive has power and I/O is in progress. If the drive firmware is automatically updating, the LED blinks.

8. If you are replacing another drive, repeat Steps 3 through 7.
9. If you disabled automatic drive assignment in Step 1, then, manually assign drive ownership and then reenables automatic drive assignment if needed.

- a. Display all unowned drives: `storage disk show -container-type unassigned`

You can enter the command on either controller module.

- b. Assign each drive: `storage disk assign -disk disk_name -owner node_name`

You can enter the command on either controller module.

You can use the wildcard character to assign more than one drive at once.

- c. Reenable automatic drive assignment if needed: `storage disk option modify -node node_name -autoassign on`

You must reenables automatic drive assignment on both controller modules.

10. Return the failed part to NetApp, as described in the RMA instructions shipped with the kit.

Contact technical support at [NetApp Support](#), 888-463-8277 (North America), 00-800-44-638277 (Europe), or +800-800-80-800 (Asia/Pacific) if you need the RMA number or additional help with the replacement procedure.

## Option 2: Replace HDD

1. If you want to manually assign drive ownership for the replacement drive, you need to disable automatic drive assignment replacement drive, if it is enabled



You manually assign drive ownership and then reenables automatic drive assignment later in this procedure.

- a. Verify whether automatic drive assignment is enabled: `storage disk option show`

You can enter the command on either controller module.

If automatic drive assignment is enabled, the output shows `on` in the "Auto Assign" column (for each controller module).

- b. If automatic drive assignment is enabled, disable it: `storage disk option modify -node node_name -autoassign off`

You must disable automatic drive assignment on both controller modules.

2. Properly ground yourself.
3. Gently remove the bezel from the front of the platform.
4. Identify the failed disk drive from the system console warning message and the illuminated fault LED on the disk drive

5. Press the release button on the disk drive face.

Depending on the storage system, the disk drives have the release button located at the top or on the left of the disk drive face.

For example, the following illustration shows a disk drive with the release button located on the top of the disk drive face:

The cam handle on the disk drive springs open partially and the disk drive releases from the midplane.

6. Pull the cam handle to its fully open position to unseat the disk drive from the midplane.

7. Slide out the disk drive slightly and allow the disk to safely spin down, which can take less than one minute, and then, using both hands, remove the disk drive from the disk shelf.

8. With the cam handle in the open position, insert the replacement disk drive into the drive bay, firmly pushing until the disk drive stops.



Wait a minimum of 10 seconds before inserting a new disk drive. This allows the system to recognize that a disk drive was removed.



If your platform drive bays are not fully loaded with drives, it is important to place the replacement drive into the same drive bay from which you removed the failed drive.



Use two hands when inserting the disk drive, but do not place hands on the disk drive boards that are exposed on the underside of the disk carrier.

9. Close the cam handle so that the disk drive is fully seated into the midplane and the handle clicks into place.

Be sure to close the cam handle slowly so that it aligns correctly with the face of the disk drive..

10. If you are replacing another disk drive, repeat Steps 4 through 9.

11. Reinstall the bezel.

12. If you disabled automatic drive assignment in Step 1, then, manually assign drive ownership and then reenables automatic drive assignment if needed.

a. Display all unowned drives: `storage disk show -container-type unassigned`

You can enter the command on either controller module.

b. Assign each drive: `storage disk assign -disk disk_name -owner owner_name`

You can enter the command on either controller module.

You can use the wildcard character to assign more than one drive at once.

c. Reenable automatic drive assignment if needed: `storage disk option modify -node node_name -autoassign on`

You must reenable automatic drive assignment on both controller modules.

13. Return the failed part to NetApp, as described in the RMA instructions shipped with the kit.

Contact technical support at [NetApp Support](#), 888-463-8277 (North America), 00-800-44-638277 (Europe), or +800-800-80-800 (Asia/Pacific) if you need the RMA number or additional help with the replacement procedure.

### Replace the NVMEM battery - ASA A150

To replace an NVMEM battery in the system, you must remove the controller module from the system, open it, replace the battery, and close and replace the controller module.

All other components in the system must be functioning properly; if not, you must contact technical support.

#### Step 1: Shut down the impaired controller

To shut down the impaired controller, you must determine the status of the controller and, if necessary, take over the controller so that the healthy controller continues to serve data from the impaired controller storage.

#### About this task

- If you have a SAN system, you must have checked event messages (`cluster kernel-service show`) for the impaired controller SCSI blade. The `cluster kernel-service show` command (from `priv advanced mode`) displays the node name, quorum status of that node, availability status of that node, and operational status of that node.

Each SCSI-blade process should be in quorum with the other nodes in the cluster. Any issues must be resolved before you proceed with the replacement.

- If you have a cluster with more than two nodes, it must be in quorum. If the cluster is not in quorum or a healthy controller shows `false` for eligibility and health, you must correct the issue before shutting down the impaired controller; see [Synchronize a node with the cluster](#).

#### Steps

1. If AutoSupport is enabled, suppress automatic case creation by invoking an AutoSupport message:  

```
system node autosupport invoke -node * -type all -message MAINT=<# of hours>h
```

The following AutoSupport message suppresses automatic case creation for two hours: `cluster1:>`  

```
system node autosupport invoke -node * -type all -message MAINT=2h
```

2. Disable automatic giveback from the console of the healthy controller: 

```
storage failover modify -node local -auto-giveback false
```



When you see *Do you want to disable auto-giveback?*, enter *y*.

3. Take the impaired controller to the LOADER prompt:

If the impaired controller is displaying...	Then...
The LOADER prompt	Go to the next step.
Waiting for giveback...	Press Ctrl-C, and then respond <i>y</i> when prompted.
System prompt or password prompt	Take over or halt the impaired controller from the healthy controller: <pre>storage failover takeover -ofnode impaired_node_name</pre> When the impaired controller shows Waiting for giveback..., press Ctrl-C, and then respond <i>y</i> .

4. If the system has only one controller module in the chassis, turn off the power supplies, and then unplug the impaired controller's power cords from the power source.

## Step 2: Remove controller module

To access components inside the controller, you must first remove the controller module from the system and then remove the cover on the controller module.

### Steps

1. If you are not already grounded, properly ground yourself.
2. Loosen the hook and loop strap binding the cables to the cable management device, and then unplug the system cables and SFPs (if needed) from the controller module, keeping track of where the cables were connected.

Leave the cables in the cable management device so that when you reinstall the cable management device, the cables are organized.

3. Remove and set aside the cable management devices from the left and right sides of the controller module.

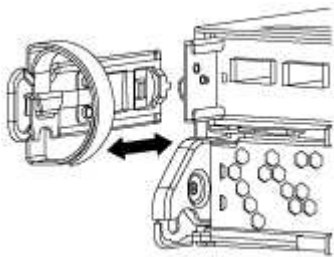

4. Squeeze the latch on the cam handle until it releases, open the cam handle fully to release the controller module from the midplane, and then, using two hands, pull the controller module out of the chassis.

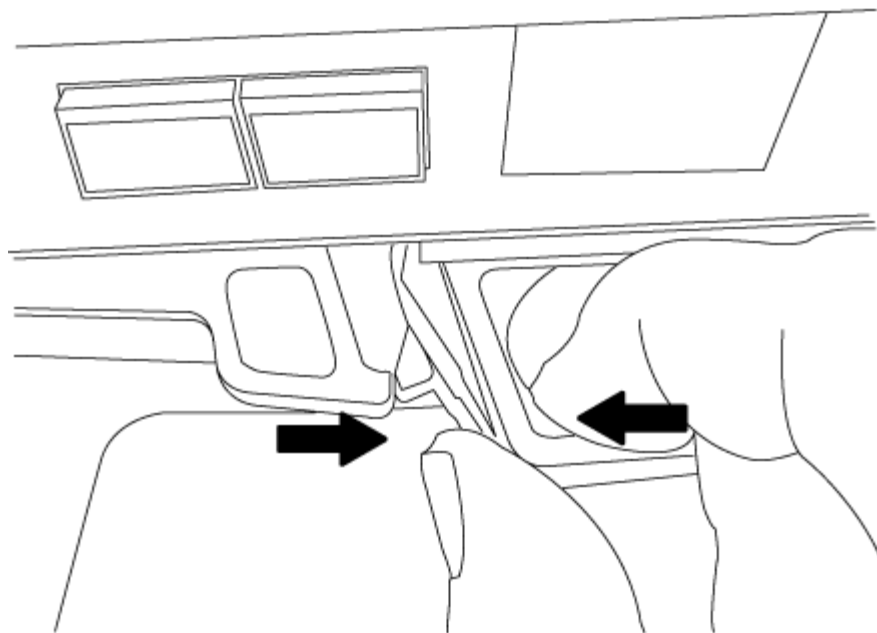

5. Turn the controller module over and place it on a flat, stable surface.
6. Open the cover by sliding in the blue tabs to release the cover, and then swing the cover up and open.

### Step 3: Replace the NVMEM battery

To replace the NVMEM battery in your system, you must remove the failed NVMEM battery from the system and replace it with a new NVMEM battery.

#### Steps

1. If you are not already grounded, properly ground yourself.
2. Check the NVMEM LED:
  - If your system is in an HA configuration, go to the next step.
  - If your system is in a stand-alone configuration, cleanly shut down the controller module, and then check the NVRAM LED identified by the NV icon.



The NVRAM LED blinks while destaging contents to the flash memory when you halt the system. After the destage is complete, the LED turns off.

- If power is lost without a clean shutdown, the NVMEM LED flashes until the destage is complete, and then the LED turns off.
- If the LED is on and power is on, unwritten data is stored on NVMEM.

This typically occurs during an uncontrolled shutdown after ONTAP has successfully booted.

3. Locate the NVMEM battery in the controller module.



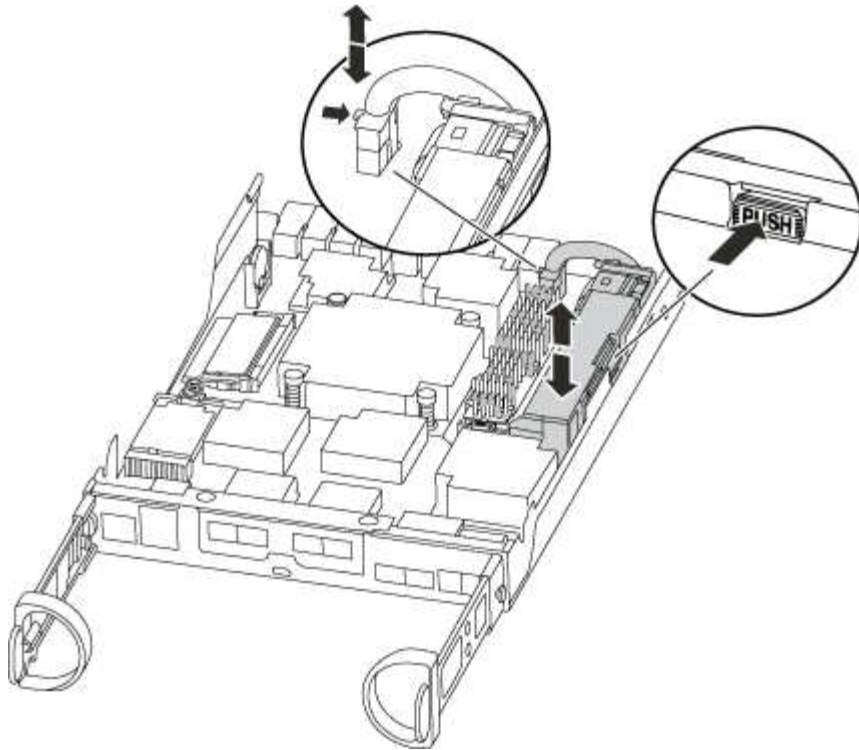

4. Locate the battery plug and squeeze the clip on the face of the battery plug to release the plug from the socket, and then unplug the battery cable from the socket.
5. Remove the battery from the controller module and set it aside.
6. Remove the replacement battery from its package.
7. Loop the battery cable around the cable channel on the side of the battery holder.
8. Position the battery pack by aligning the battery holder key ribs to the “V” notches on the sheet metal side wall.
9. Slide the battery pack down along the sheet metal side wall until the support tabs on the side wall hook into the slots on the battery pack, and the battery pack latch engages and clicks into the opening on the side wall.
10. Plug the battery plug back into the controller module.

#### Step 4: Reinstall the controller module

After you replace components in the controller module, reinstall it into the chassis.

##### Steps

1. If you are not already grounded, properly ground yourself.
2. If you have not already done so, replace the cover on the controller module.
3. Align the end of the controller module with the opening in the chassis, and then gently push the controller module halfway into the system.





Do not completely insert the controller module in the chassis until instructed to do so.

4. Recable the system, as needed.

If you removed the media converters (QSFPs or SFPs), remember to reinstall them if you are using fiber

optic cables.

5. Complete the reinstallation of the controller module:

If your system is in...	Then perform these steps...
An HA pair	<p>The controller module begins to boot as soon as it is fully seated in the chassis.</p> <ol style="list-style-type: none"><li>With the cam handle in the open position, firmly push the controller module in until it meets the midplane and is fully seated, and then close the cam handle to the locked position.</li></ol> <div data-bbox="703 552 756 604"></div> <div data-bbox="816 531 1360 632"><p>Do not use excessive force when sliding the controller module into the chassis to avoid damaging the connectors.</p></div> <p>The controller begins to boot as soon as it is seated in the chassis.</p> <ol style="list-style-type: none"><li>If you have not already done so, reinstall the cable management device.</li><li>Bind the cables to the cable management device with the hook and loop strap.</li></ol>
A stand-alone configuration	<ol style="list-style-type: none"><li>With the cam handle in the open position, firmly push the controller module in until it meets the midplane and is fully seated, and then close the cam handle to the locked position.</li></ol> <div data-bbox="703 1146 756 1199"></div> <div data-bbox="816 1125 1360 1226"><p>Do not use excessive force when sliding the controller module into the chassis to avoid damaging the connectors.</p></div> <ol style="list-style-type: none"><li>If you have not already done so, reinstall the cable management device.</li><li>Bind the cables to the cable management device with the hook and loop strap.</li><li>Reconnect the power cables to the power supplies and to the power sources, turn on the power to start the boot process.</li></ol>

**Step 5: Switch back aggregates in a two-node MetroCluster configuration**

After you have completed the FRU replacement in a two-node MetroCluster configuration, you can perform the MetroCluster switchback operation. This returns the configuration to its normal operating state, with the sync-source storage virtual machines (SVMs) on the formerly impaired site now active and serving data from the local disk pools.

This task only applies to two-node MetroCluster configurations.

## Steps

1. Verify that all nodes are in the enabled state: `metrocluster node show`

```
cluster_B::> metrocluster node show

DR                               Configuration  DR
Group Cluster Node              State          Mirroring Mode
-----
1      cluster_A
      controller_A_1 configured      enabled      heal roots
completed
      cluster_B
      controller_B_1 configured      enabled      waiting for
switchback recovery
2 entries were displayed.
```

2. Verify that resynchronization is complete on all SVMs: `metrocluster vserver show`
3. Verify that any automatic LIF migrations being performed by the healing operations were completed successfully: `metrocluster check lif show`
4. Perform the switchback by using the `metrocluster switchback` command from any node in the surviving cluster.
5. Verify that the switchback operation has completed: `metrocluster show`

The switchback operation is still running when a cluster is in the `waiting-for-switchback` state:

```
cluster_B::> metrocluster show
Cluster              Configuration State      Mode
-----
Local: cluster_B configured      switchover
Remote: cluster_A configured      waiting-for-switchback
```

The switchback operation is complete when the clusters are in the `normal` state.:

```
cluster_B::> metrocluster show
Cluster              Configuration State      Mode
-----
Local: cluster_B configured      normal
Remote: cluster_A configured      normal
```

If a switchback is taking a long time to finish, you can check on the status of in-progress baselines by using the `metrocluster config-replication resync-status show` command.

6. Reestablish any SnapMirror or SnapVault configurations.

### Step 6: Return the failed part to NetApp

Return the failed part to NetApp, as described in the RMA instructions shipped with the kit. See the [Part Return and Replacements](#) page for further information.

#### Swap out a power supply - ASA A150

Swapping out a power supply involves turning off, disconnecting, and removing the old power supply and installing, connecting, and turning on the replacement power supply.

All other components in the system must be functioning properly; if not, you must contact technical support.

- The power supplies are redundant and hot-swappable.
- This procedure is written for replacing one power supply at a time.



Cooling is integrated with the power supply, so you must replace the power supply within two minutes of removal to prevent overheating due to reduced airflow. Because the chassis provides a shared cooling configuration for the two HA nodes, a delay longer than two minutes will shut down all controller modules in the chassis. If both controller modules do shut down, make sure that both power supplies are inserted, turn both off for 30 seconds, and then turn both on.

- Power supplies are auto-ranging.

### Steps

1. Identify the power supply you want to replace, based on console error messages or through the LEDs on the power supplies.
2. If you are not already grounded, properly ground yourself.
3. Turn off the power supply and disconnect the power cables:
  - a. Turn off the power switch on the power supply.
  - b. Open the power cable retainer, and then unplug the power cable from the power supply.
  - c. Unplug the power cable from the power source.
4. Squeeze the latch on the power supply cam handle, and then open the cam handle to fully release the power supply from the mid plane.

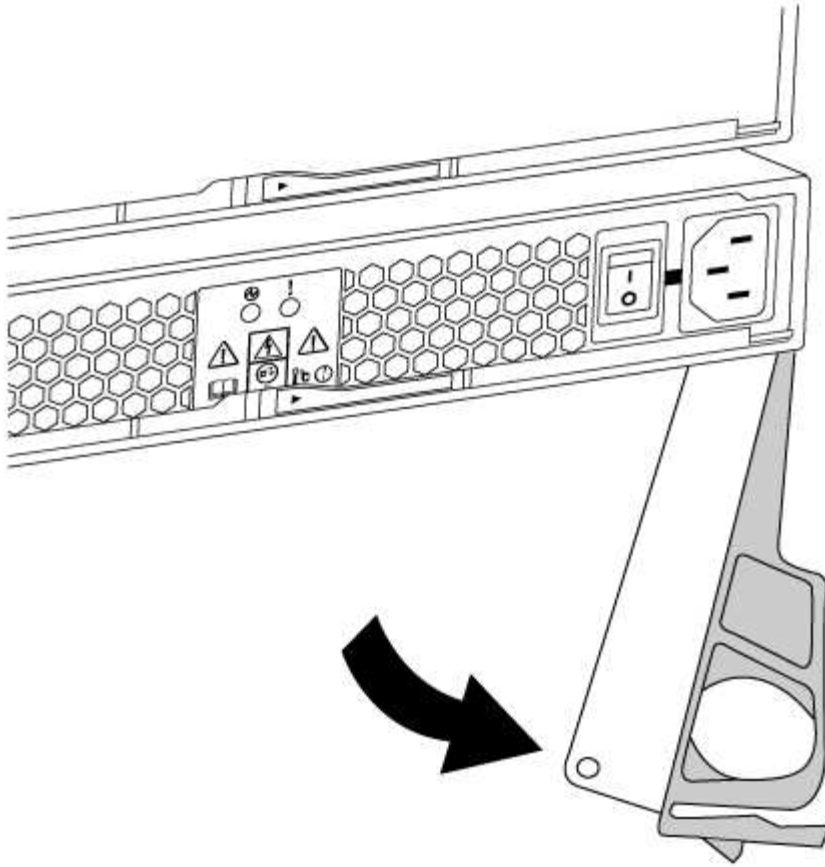

5. Use the cam handle to slide the power supply out of the system.



When removing a power supply, always use two hands to support its weight.

6. Make sure that the on/off switch of the new power supply is in the Off position.
7. Using both hands, support and align the edges of the power supply with the opening in the system chassis, and then gently push the power supply into the chassis using the cam handle.

The power supplies are keyed and can only be installed one way.



Do not use excessive force when sliding the power supply into the system. You can damage the connector.

8. Close the cam handle so that the latch clicks into the locked position and the power supply is fully seated.
9. Reconnect the power supply cabling:
- Reconnect the power cable to the power supply and the power source.
  - Secure the power cable to the power supply using the power cable retainer.

Once power is restored to the power supply, the status LED should be green.

10. Turn on the power to the new power supply, and then verify the operation of the power supply activity LEDs.

The power supply LEDs are lit when the power supply comes online.

11. Return the failed part to NetApp, as described in the RMA instructions shipped with the kit. See the [Part Return and Replacements](#) page for further information.

### Replace the real-time clock battery - ASA A150

You replace the real-time clock (RTC) battery in the controller module so that your system's services and applications that depend on accurate time synchronization continue to function.

- You can use this procedure with all versions of ONTAP supported by your system
- All other components in the system must be functioning properly; if not, you must contact technical support.

### Step 1: Shut down the impaired controller

To shut down the impaired controller, you must determine the status of the controller and, if necessary, take over the controller so that the healthy controller continues to serve data from the impaired controller storage.

#### About this task

- If you have a SAN system, you must have checked event messages (`cluster kernel-service show`) for the impaired controller SCSI blade. The `cluster kernel-service show` command (from `priv advanced` mode) displays the node name, quorum status of that node, availability status of that node, and operational status of that node.

Each SCSI-blade process should be in quorum with the other nodes in the cluster. Any issues must be resolved before you proceed with the replacement.

- If you have a cluster with more than two nodes, it must be in quorum. If the cluster is not in quorum or a healthy controller shows false for eligibility and health, you must correct the issue before shutting down the impaired controller; see [Synchronize a node with the cluster](#).

#### Steps

1. If AutoSupport is enabled, suppress automatic case creation by invoking an AutoSupport message:  
`system node autosupport invoke -node * -type all -message MAINT=<# of hours>h`

The following AutoSupport message suppresses automatic case creation for two hours: `cluster1:> system node autosupport invoke -node * -type all -message MAINT=2h`

2. Disable automatic giveback from the console of the healthy controller: `storage failover modify -node local -auto-giveback false`



When you see *Do you want to disable auto-giveback?*, enter *y*.

3. Take the impaired controller to the LOADER prompt:

If the impaired controller is displaying...	Then...
The LOADER prompt	Go to the next step.
Waiting for giveback...	Press Ctrl-C, and then respond <i>y</i> when prompted.

If the impaired controller is displaying...	Then...
System prompt or password prompt	<p>Take over or halt the impaired controller from the healthy controller:  <code>storage failover takeover -ofnode</code>  <code>impaired_node_name</code></p> <p>When the impaired controller shows Waiting for giveback..., press Ctrl-C, and then respond <code>y</code>.</p>

## Step 2: Remove controller module

To access components inside the controller, you must first remove the controller module from the system and then remove the cover on the controller module.

1. If you are not already grounded, properly ground yourself.
2. Loosen the hook and loop strap binding the cables to the cable management device, and then unplug the system cables and SFPs (if needed) from the controller module, keeping track of where the cables were connected.

Leave the cables in the cable management device so that when you reinstall the cable management device, the cables are organized.

3. Remove and set aside the cable management devices from the left and right sides of the controller module.

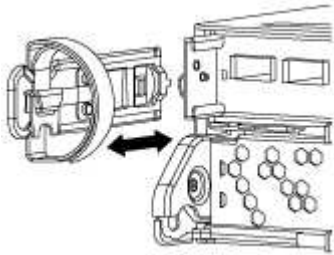

4. Squeeze the latch on the cam handle until it releases, open the cam handle fully to release the controller module from the midplane, and then, using two hands, pull the controller module out of the chassis.

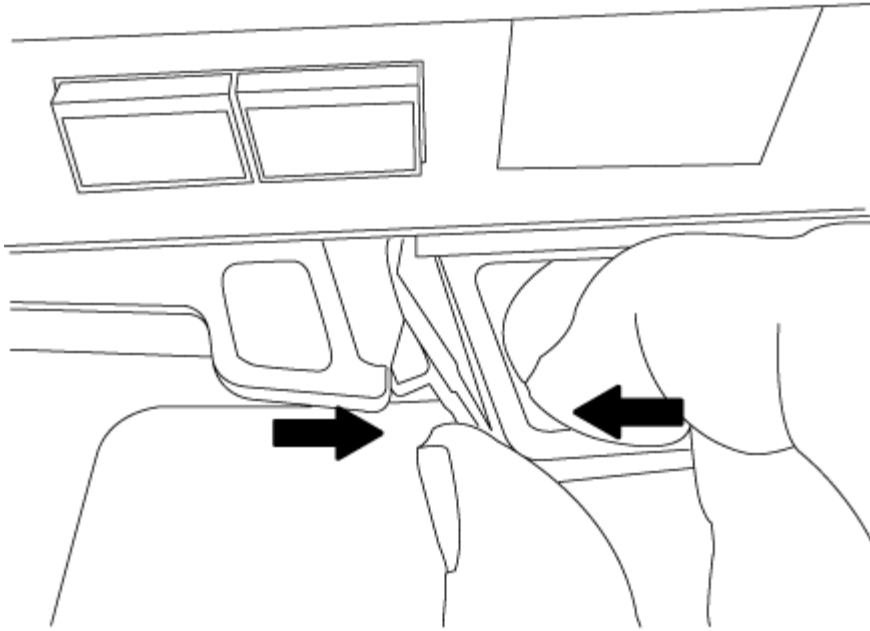

5. Turn the controller module over and place it on a flat, stable surface.
6. Open the cover by sliding in the blue tabs to release the cover, and then swing the cover up and open.

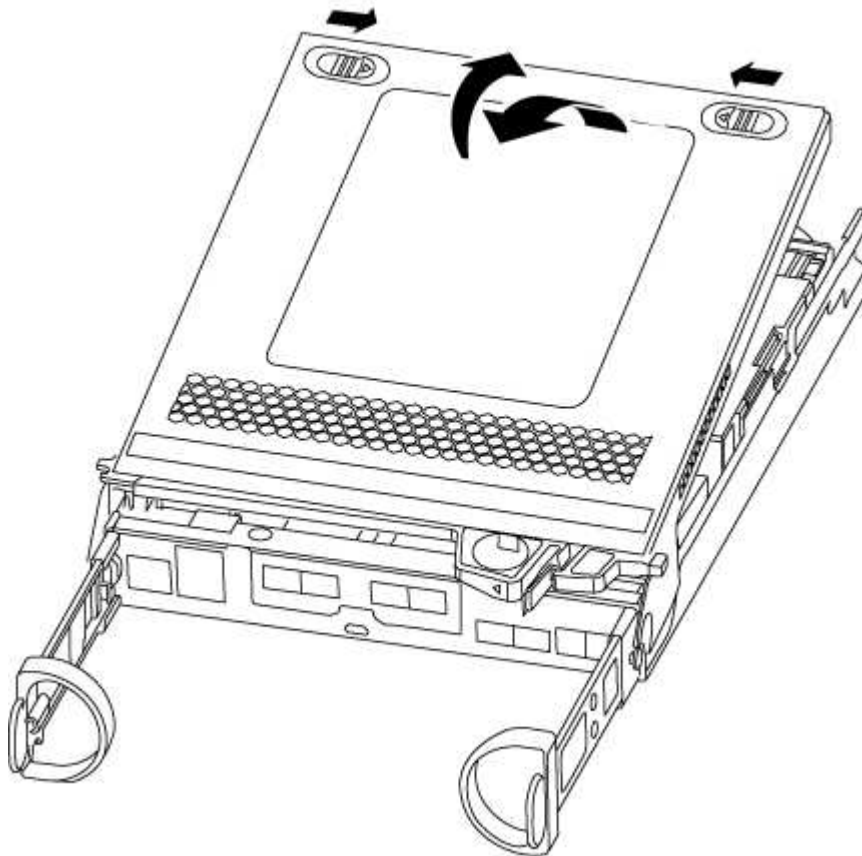

### Step 3: Replace the RTC battery

To replace the RTC battery, locate it inside the controller and follow the specific sequence of steps.



1. If you are not already grounded, properly ground yourself.
2. Locate the RTC battery.

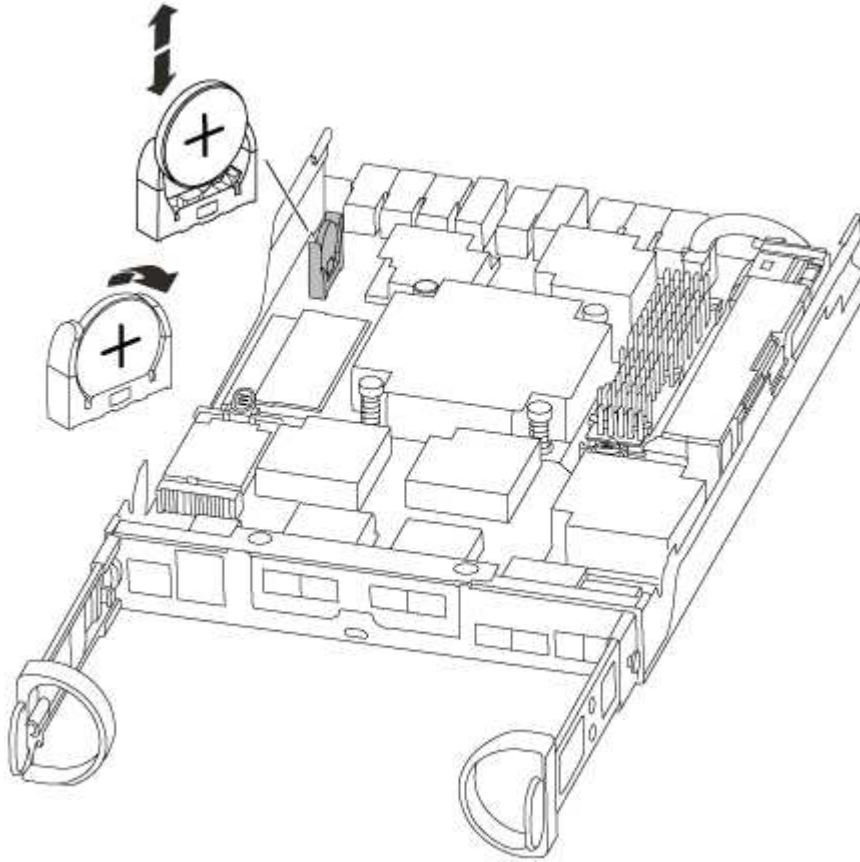

3. Gently push the battery away from the holder, rotate it away from the holder, and then lift it out of the holder.



Note the polarity of the battery as you remove it from the holder. The battery is marked with a plus sign and must be positioned in the holder correctly. A plus sign near the holder tells you how the battery should be positioned.

4. Remove the replacement battery from the antistatic shipping bag.
5. Locate the empty battery holder in the controller module.
6. Note the polarity of the RTC battery, and then insert it into the holder by tilting the battery at an angle and pushing down.
7. Visually inspect the battery to make sure that it is completely installed into the holder and that the polarity is correct.

#### **Step 4: Reinstall the controller module and set time/date after RTC battery replacement**

After you replace a component within the controller module, you must reinstall the controller module in the system chassis, reset the time and date on the controller, and then boot it.

1. If you have not already done so, close the air duct or controller module cover.
2. Align the end of the controller module with the opening in the chassis, and then gently push the controller module halfway into the system.

Do not completely insert the controller module in the chassis until instructed to do so.

3. Recable the system, as needed.

If you removed the media converters (QSFPs or SFPs), remember to reinstall them if you are using fiber optic cables.

4. If the power supplies were unplugged, plug them back in and reinstall the power cable retainers.
5. Complete the reinstallation of the controller module:

- a. With the cam handle in the open position, firmly push the controller module in until it meets the midplane and is fully seated, and then close the cam handle to the locked position.



Do not use excessive force when sliding the controller module into the chassis to avoid damaging the connectors.

- b. If you have not already done so, reinstall the cable management device.
  - c. Bind the cables to the cable management device with the hook and loop strap.
  - d. Reconnect the power cables to the power supplies and to the power sources, and then turn on the power to start the boot process.
  - e. Halt the controller at the LOADER prompt.
6. Reset the time and date on the controller:
    - a. Check the date and time on the healthy controller with the `show date` command.
    - b. At the LOADER prompt on the target controller, check the time and date.
    - c. If necessary, modify the date with the `set date mm/dd/yyyy` command.
    - d. If necessary, set the time, in GMT, using the `set time hh:mm:ss` command.
    - e. Confirm the date and time on the target controller.
  7. At the LOADER prompt, enter `bye` to reinitialize the PCIe cards and other components and let the controller reboot.
  8. Return the controller to normal operation by giving back its storage: `storage failover giveback -ofnode impaired_node_name`
  9. If automatic giveback was disabled, reenable it: `storage failover modify -node local -auto-giveback true`

## Step 5: Switch back aggregates in a two-node MetroCluster configuration

After you have completed the FRU replacement in a two-node MetroCluster configuration, you can perform the MetroCluster switchback operation. This returns the configuration to its normal operating state, with the sync-source storage virtual machines (SVMs) on the formerly impaired site now active and serving data from the local disk pools.

This task only applies to two-node MetroCluster configurations.

### Steps

1. Verify that all nodes are in the `enabled state`: `metrocluster node show`

```

cluster_B::> metrocluster node show

DR                               Configuration  DR
Group Cluster Node              State          Mirroring Mode
-----
1      cluster_A
      controller_A_1 configured      enabled      heal roots
completed
      cluster_B
      controller_B_1 configured      enabled      waiting for
switchback recovery
2 entries were displayed.

```

2. Verify that resynchronization is complete on all SVMs: `metrocluster vserver show`
3. Verify that any automatic LIF migrations being performed by the healing operations were completed successfully: `metrocluster check lif show`
4. Perform the switchback by using the `metrocluster switchback` command from any node in the surviving cluster.
5. Verify that the switchback operation has completed: `metrocluster show`

The switchback operation is still running when a cluster is in the `waiting-for-switchback` state:

```

cluster_B::> metrocluster show
Cluster              Configuration State      Mode
-----
Local: cluster_B configured      switchover
Remote: cluster_A configured      waiting-for-switchback

```

The switchback operation is complete when the clusters are in the `normal` state.:

```

cluster_B::> metrocluster show
Cluster              Configuration State      Mode
-----
Local: cluster_B configured      normal
Remote: cluster_A configured      normal

```

If a switchback is taking a long time to finish, you can check on the status of in-progress baselines by using the `metrocluster config-replication resync-status show` command.

6. Reestablish any SnapMirror or SnapVault configurations.

## Step 6: Return the failed part to NetApp

Return the failed part to NetApp, as described in the RMA instructions shipped with the kit. See the [Part Return and Replacements](#) page for further information.

## ASA A250 systems

### Install and setup

**Start here: Choose your installation and setup experience**

For most configurations, you can choose from different content formats.

- [Quick steps](#)

A printable PDF of step-by-step instructions with live links to additional content.

- [Video steps](#)

Video step-by-step instructions.

- [Detailed steps](#)

Online step-by-step instructions with live links to additional content.

If your system is in a MetroCluster IP configuration, see the [Install MetroCluster IP Configuration](#) instructions.

#### Quick steps - ASA A250

The Installation and Setup instructions give graphic instructions for a typical installation of your system, from racking and cabling, through initial system bring-up. Use this guide if you are familiar with installing NetApp systems.



The ASA A250 and ASA C250 use the same installation procedure as the AFF A250 system.

[AFF A250 Installation and Setup Instructions](#)

#### Video steps - ASA A250

The following video shows how to install and cable your new system.

[Animation - Installation and Setup of an AFF A250](#)



The ASA A250 uses the same installation procedure as the AFF A250 system.

#### Detailed steps - ASA A250

This page gives detailed step-by-step instructions for installing an ASA A250 system.

### Step 1: Prepare for installation

To install your system, you need to create an account and register the system. You also need to inventory the

appropriate number and type of cables for your system and collect specific network information.



Customers with specific power requirements must check HWU for their configuration options.

### Before you begin

- Make sure you have access to the [NetApp Hardware Universe](#) (HWU) for information about site requirements.
- Make sure you have access to the [Release Notes for your version of ONTAP](#) for more information about this system.
- You need to provide the following at your site:
  - Rack space for the storage system
  - Phillips #2 screwdriver
  - Additional networking cables to connect your system to your network switch and laptop or console with a Web browser

### Steps





1. Unpack the contents of all boxes.
2. Record the system serial number from the controllers.



3. Set up your account:
  - a. Log in to your existing account or create an account.
  - b. [Register](#) your system.
4. Download and install [NetApp Downloads: Config Advisor](#) on your laptop.
5. Inventory and make a note of the number and types of cables you received.

The following table identifies the types of cables you might receive. If you receive a cable not listed in the table, see the [NetApp Hardware Universe](#) to locate the cable and identify its use.

Type of cable...	Part number and length	Connector type	For...
25 GbE cable	X66240A-05 (112-00595), 0.5m; X66240-2 (112-00573), 2m		Cluster interconnect network
	X66240A-2 (112-00598), 2m; X66240A-5 (112-00600), 5m		Data
100 GbE cable	X66211-2 (112-00574), 2m; X66211-5 (112-00576), 5m		Storage

Type of cable...	Part number and length	Connector type	For...
RJ-45 (order dependent)	Not applicable		Management network (BMC and wrench port) and Ethernet data (e0a and e0b)
Fibre Channel	X66250-2 (112-00342) 2m; X66250-5 (112-00344) 5m; X66250-15 (112-00346) 15m; X66250-30 (112-00347) 30m		
Micro-USB console cable	Not applicable		Console connection during software setup
Power cables	Not applicable		Powering up the system

6. Review the [ONTAP Configuration Guide](#) and collect the required information listed in that guide.

## Step 2: Install the hardware

You need to install your system in a 4-post rack or NetApp system cabinet, as applicable.

### Steps

1. Install the rail kits, as needed.
2. Install and secure your system using the instructions included with the rail kit.



You need to be aware of the safety concerns associated with the weight of the system.

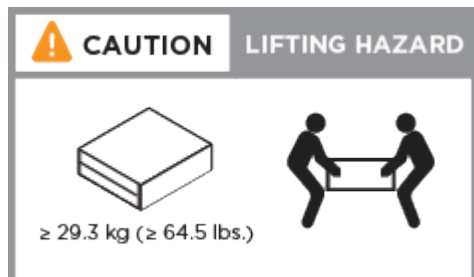

3. Identify and manage cables because this system does not have a cable management device.
4. Place the bezel on the front of the system.

## Step 3: Cable controllers to cluster

Cable the controllers to a cluster by using the two-node switchless cluster method or by using the cluster interconnect network method.

### Option 1: Two-node switchless cluster

The management, Fibre Channel, and data or host network ports on the controller modules are connected to switches. The cluster interconnect ports are cabled on both controller modules.

#### Before you begin

- Contact your network administrator for information about connecting the system to the switches.
- Be sure to check the illustration arrow for the proper cable connector pull-tab orientation.

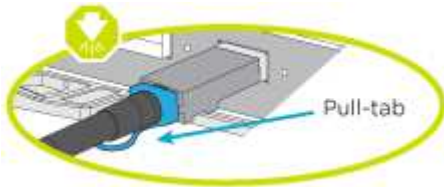

As you insert the connector, you should feel it click into place; if you do not feel it click, remove it, turn it around and try again.

#### About this task

Use the animation or the tabulated steps to complete the cabling between the controllers and the switches. Perform the steps on each controller.

#### Animation - Cable two-node switchless cluster

#### Steps

1. Use the the 25GbE cluster interconnect cable to connect the cluster interconnect ports e0c to e0c and e0d to e0d.

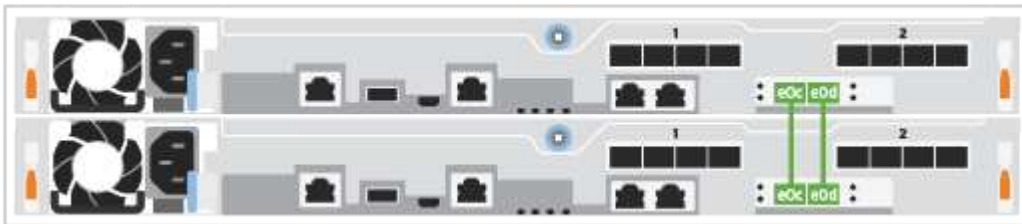

2. Cable the wrench ports to the management network switches with the RJ45 cables.

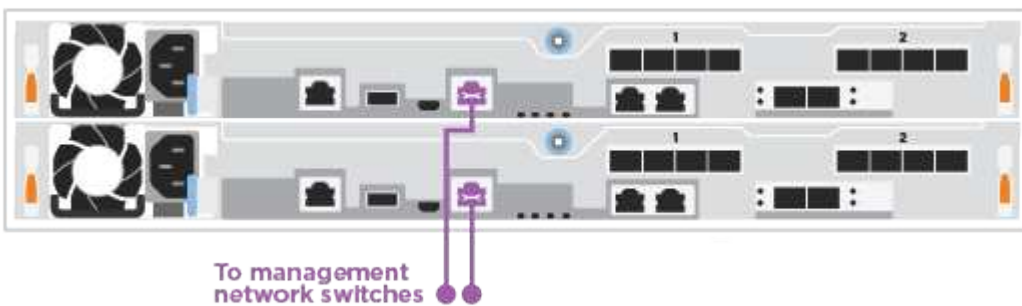

To management network switches



DO NOT plug in the power cords at this point.

## Option 2: Switched cluster

All ports on the controllers are connected to switches; cluster interconnect, management, Fibre Channel, and data or host network switches.

### Before you begin

- Contact your network administrator for information about connecting the system to the switches.
- Be sure to check the illustration arrow for the proper cable connector pull-tab orientation.

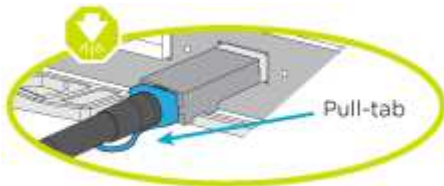

As you insert the connector, you should feel it click into place; if you do not feel it click, remove it, turn it around and try again.

### About this task

Use the animation or the steps to complete the cabling between the controllers and the switches. Perform the steps on each controller.

[Animation - Cable switched cluster](#)

### Steps

1. Cable the cluster interconnect ports e0c and e0d to the 25 GbE cluster interconnect switches.

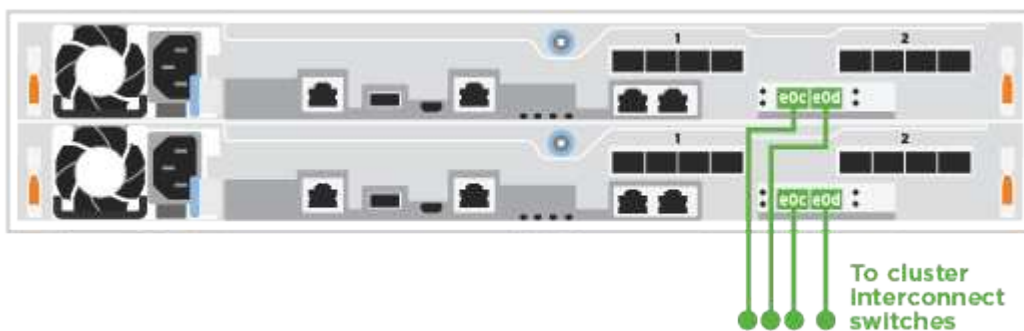

2. Cable the wrench ports to the management network switches with the RJ45 cables.



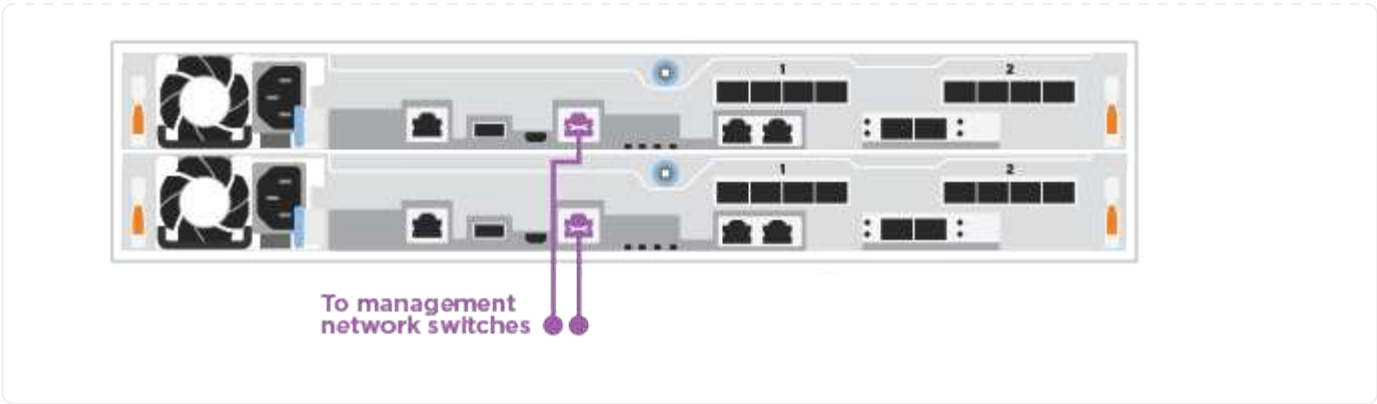

**Step 4: Cable to host network or storage (Optional)**

You have configuration-dependent optional cabling to the Fibre Channel or iSCSI host networks or direct-attached storage. This cabling is not exclusive; you can have cabling to a host network and storage.

### Option 1: Cable to Fibre Channel host network

Fibre Channel ports on the controllers are connected to Fibre Channel host network switches.

#### Before you begin

- Contact your network administrator for information about connecting the system to the switches.
- Be sure to check the illustration arrow for the proper cable connector pull-tab orientation.

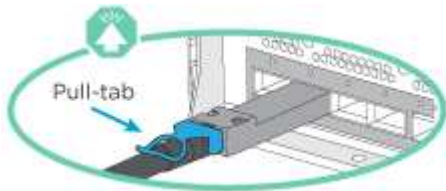

As you insert the connector, you should feel it click into place; if you do not feel it click, remove it, turn it around and try again..

#### About this task

Perform the following step on each controller module.

#### Steps

1. Cable ports 2a through 2d to the FC host switches.

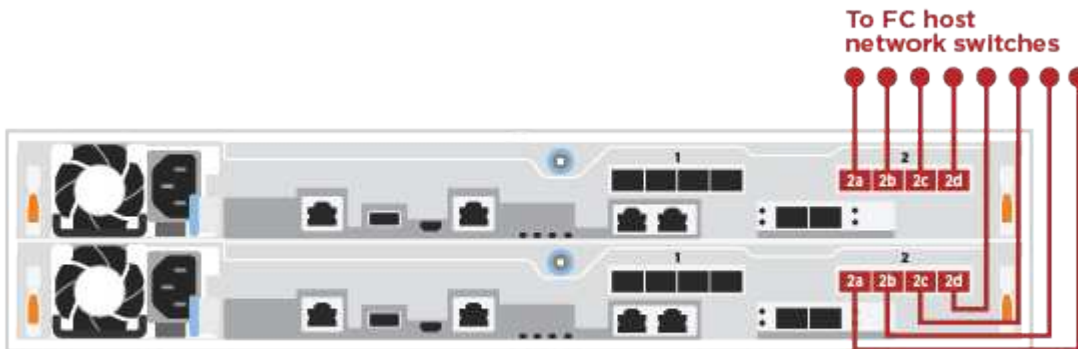

### Option 2: Cable to 25GbE data or host network

25GbE ports on the controllers are connected to 25GbE data or host network switches.

#### Before you begin

- Contact your network administrator for information about connecting the system to the switches.
- Be sure to check the illustration arrow for the proper cable connector pull-tab orientation.

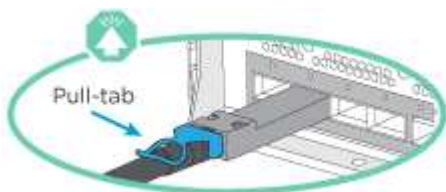



As you insert the connector, you should feel it click into place; if you do not feel it click, remove it, turn it around and try again.

### About this task

Perform the following step on each controller module.

### Steps

1. Cable ports e4a through e4d to the 10GbE host network switches.

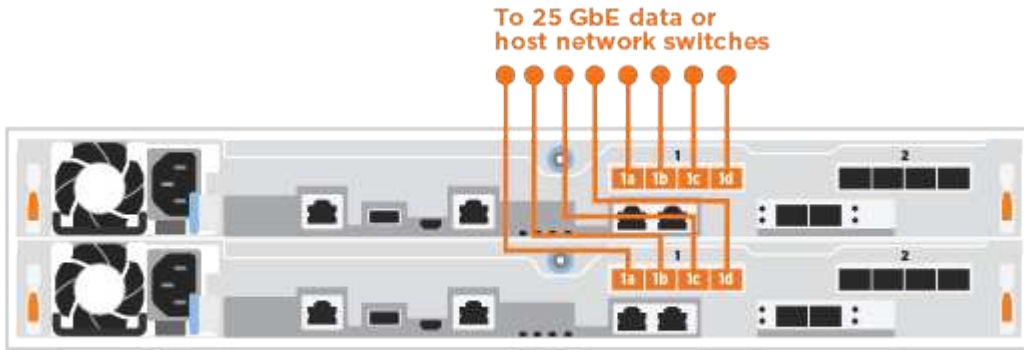

### Option 3: Cable controllers to single drive shelf

Cable each controller to the NSM modules on the NS224 drive shelf.

### Before you begin

Be sure to check the illustration arrow for the proper cable connector pull-tab orientation.

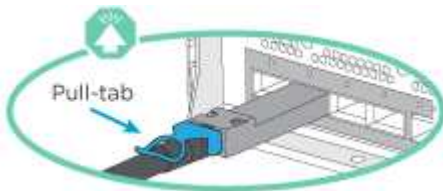

As you insert the connector, you should feel it click into place; if you do not feel it click, remove it, turn it around and try again.

### About this task

Use the animation or the tabulated steps to complete the cabling between the controllers and the single shelf. Perform the steps on each controller module.

[Animation - Cable the controllers to a single NS224](#)

### Steps

1. Cable controller A to the shelf.

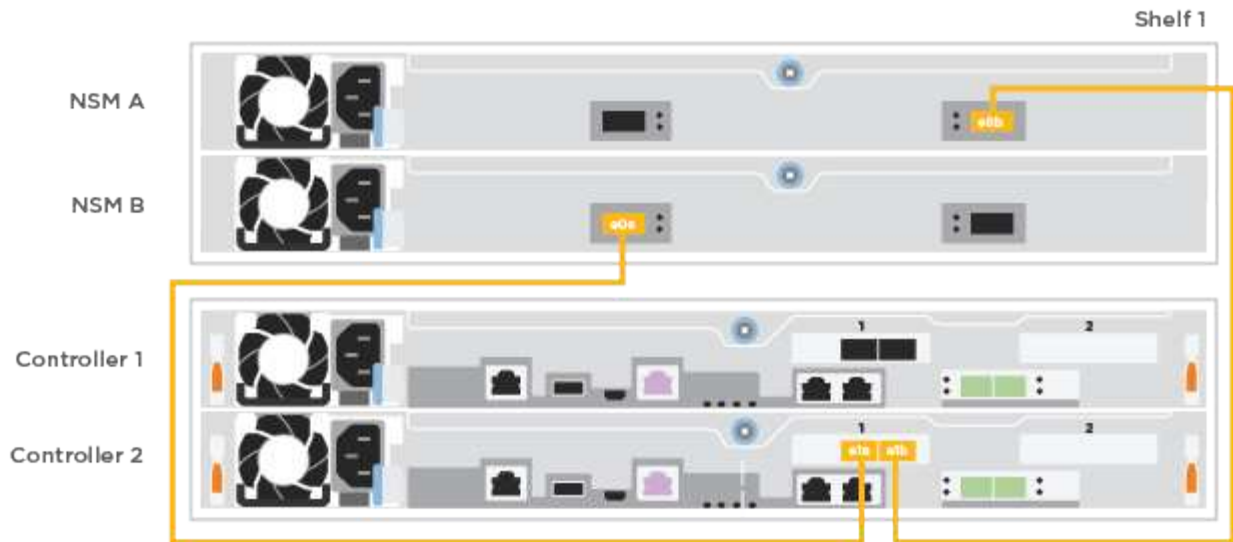

2. Cable controller B to the shelf.

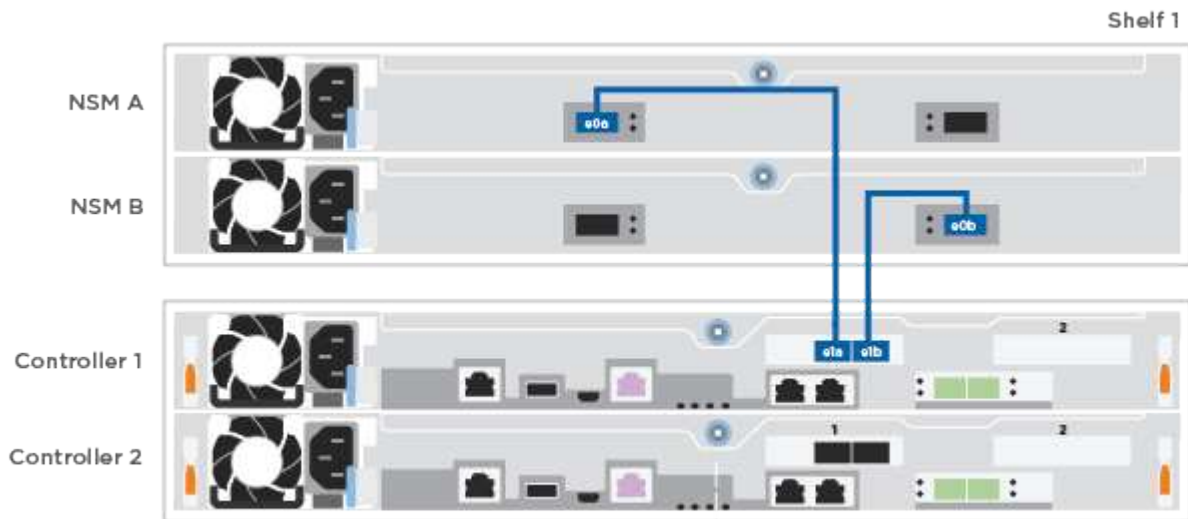

### Step 5: Complete system setup

Complete the system setup and configuration using cluster discovery with only a connection to the switch and laptop, or by connecting directly to a controller in the system and then connecting to the management switch.

### Option 1: If network discovery is enabled

If you have network discovery enabled on your laptop, you can complete system setup and configuration using automatic cluster discovery.

#### Steps

1. Plug the power cords into the controller power supplies, and then connect them to power sources on different circuits.

The system begins to boot. Initial booting may take up to eight minutes.

2. Make sure that your laptop has network discovery enabled.

See your laptop's online help for more information.

3. Use the animation to connect your laptop to the Management switch:

[Animation - Connect your laptop to the Management switch](#)

4. Select an ONTAP icon listed to discover:

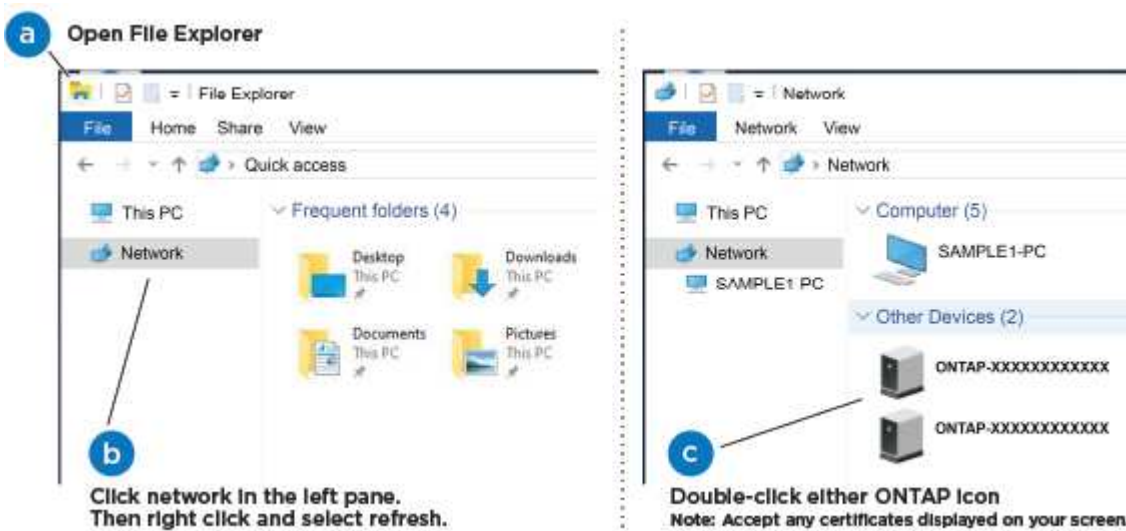

- a. Open File Explorer.
- b. Click **Network** in the left pane.
- c. Right-click and select **refresh**.
- d. Double-click either ONTAP icon and accept any certificates displayed on your screen.



XXXXX is the system serial number for the target node.

System Manager opens.

5. Use System Manager guided setup to configure your system using the data you collected in the [ONTAP Configuration Guide](#).
6. Verify the health of your system by running Config Advisor.
7. After you have completed the initial configuration, go to the [ONTAP & ONTAP System Manager](#)

[Documentation Resources](#) page for information about configuring additional features in ONTAP.

### Option 2: If network discovery is not enabled

If network discovery is not enabled on your laptop, you must complete the configuration and setup using this task.

#### Steps

1. Cable and configure your laptop or console:

a. Set the console port on the laptop or console to 115,200 baud with N-8-1.



See your laptop or console's online help for how to configure the console port.

b. Connect the laptop or console to the switch on the management subnet.



c. Assign a TCP/IP address to the laptop or console, using one that is on the management subnet.

2. Plug the power cords into the controller power supplies, and then connect them to power sources on different circuits.

The system begins to boot. Initial booting may take up to eight minutes.

3. Assign an initial node management IP address to one of the nodes.

If the management network has DHCP...	Then...
Configured	Record the IP address assigned to the new controllers.
Not configured	<p>a. Open a console session using PuTTY, a terminal server, or the equivalent for your environment.</p> <p> Check your laptop or console's online help if you do not know how to configure PuTTY.</p> <p>b. Enter the management IP address when prompted by the script.</p>

4. Using System Manager on your laptop or console, configure your cluster:

a. Point your browser to the node management IP address.



The format for the address is `https://x.x.x.x`.

- b. Configure the system using the data you collected in the [ONTAP Configuration Guide](#).
5. Verify the health of your system by running Config Advisor.
6. After you have completed the initial configuration, go to the [ONTAP & ONTAP System Manager Documentation Resources](#) page for information about configuring additional features in ONTAP.

## Maintain

### Maintain ASA A250 hardware

For the ASA A250 storage system, you can perform maintenance procedures on the following components.

#### Boot media

The boot media stores a primary and secondary set of boot image files that the system uses when it boots.

#### Chassis

The chassis is the physical enclosure housing all the controller components such as the controller/CPU unit, power supply, and I/O.

#### Controller

A controller consists of a board, firmware, and software. It controls the drives and implements the ONTAP functions.

#### DIMM

You must replace a DIMM (dual in-line memory module) when a memory mismatch is present, or you have a failed DIMM.

#### Drive

A drive is a device that provides the physical storage media for data.

#### Fan

The fan cools the controller.

#### Mezzanine card

A Mezzanine card is a printed circuit board that plugs directly into another plug-in card.

#### NVEM battery

A battery is included with the controller and preserves cached data if the AC power fails.

#### Power supply

A power supply provides a redundant power source in a controller shelf.

## Real time clock battery

A real time clock battery preserves system date and time information if the power is off.

## Boot media

### Overview and requirements ASA A250

The boot media stores a primary and secondary set of system (boot image) files that the system uses when it boots.

### Before you begin

- You must have a USB flash drive, formatted to MBR/FAT32, with the appropriate amount of storage to hold the `image_XXX.tgz` file.
- You also must copy the `image_XXX.tgz` file to the USB flash drive for later use in this procedure.

### About this task

- The nondisruptive and disruptive methods for replacing a boot media both require you to restore the `var` file system:
  - For nondisruptive replacement, the HA pair must be connected to a network to restore the `var` file system.
  - For disruptive replacement, you do not need a network connection to restore the `var` file system, but the process requires two reboots.
- You must replace the failed component with a replacement FRU component you received from your provider.
- It is important that you apply the commands in these steps on the correct controller:
  - The *impaired* node is the controller on which you are performing maintenance.
  - The *healthy* node is the HA partner of the impaired controller.

### Check onboard encryption keys - ASA A250

Prior to shutting down the impaired controller and checking the status of the onboard encryption keys, you must check the status of the impaired controller, disable automatic giveback, and check which version of ONTAP is running on the system.

If you have a cluster with more than two nodes, it must be in quorum. If the cluster is not in quorum or a healthy controller shows false for eligibility and health, you must correct the issue before shutting down the impaired controller; see the [Synchronize a node with the cluster](#).

### Steps

1. Check the status of the impaired controller:
  - If the impaired controller is at the login prompt, log in as `admin`.
  - If the impaired controller is at the LOADER prompt and is part of HA configuration, log in as `admin` on the healthy controller.
  - If the impaired controller is in a standalone configuration and at LOADER prompt, contact [mysupport.netapp.com](https://mysupport.netapp.com).
2. If AutoSupport is enabled, suppress automatic case creation by invoking an AutoSupport message:



```
system node autosupport invoke -node * -type all -message  
MAINT=number_of_hours_downh
```

The following AutoSupport message suppresses automatic case creation for two hours: `cluster1:*>`  
`system node autosupport invoke -node * -type all -message MAINT=2h`

3. Check the version of ONTAP the system is running on the impaired controller if up, or on the partner controller if the impaired controller is down, using the `version -v` command:
  - If `<Ino-DARE>` or `<1Ono-DARE>` is displayed in the command output, the system does not support NVE, proceed to shut down the controller.
  - If `<Ino-DARE>` is not displayed in the command output, and the system is running ONTAP 9.6 or later, go to the next section.
4. If the impaired controller is part of an HA configuration, disable automatic giveback from the healthy controller: `storage failover modify -node local -auto-giveback false` or `storage failover modify -node local -auto-giveback-after-panic false`

### Check NVE or NSE on systems running ONTAP 9.6 and later

Before shutting down the impaired controller, you need to verify whether the system has either NetApp Volume Encryption (NVE) or NetApp Storage Encryption (NSE) enabled. If so, you need to verify the configuration.

1. Verify whether NVE is in use for any volumes in the cluster: `volume show -is-encrypted true`

If any volumes are listed in the output, NVE is configured and you need to verify the NVE configuration. If no volumes are listed, check whether NSE is configured and in use.

2. Verify whether NSE is configured and in use: `storage encryption disk show`
  - If the command output lists the drive details with Mode & Key ID information, NSE is configured and you need to verify the NSE configuration and in use.
  - If no disks are shown, NSE is not configured.
  - If NVE and NSE are not configured, no drives are protected with NSE keys, it's safe to shut down the impaired controller.

### Verify NVE configuration

1. Display the key IDs of the authentication keys that are stored on the key management servers: `security key-manager key query`



After the ONTAP 9.6 release, you may have additional key manager types. The types are KMIP, AKV, and GCP. The process for confirming these types is the same as confirming `external` or `onboard` key manager types.

- If the `Key Manager` type displays `external` and the `Restored` column displays `yes`, it's safe to shut down the impaired controller.
- If the `Key Manager` type displays `onboard` and the `Restored` column displays `yes`, you need to complete some additional steps.
- If the `Key Manager` type displays `external` and the `Restored` column displays anything other than `yes`, you need to complete some additional steps.

- If the Key Manager type displays `onboard` and the Restored column displays anything other than `yes`, you need to complete some additional steps.
2. If the Key Manager type displays `onboard` and the Restored column displays `yes`, manually back up the OKM information:
    - a. Go to advanced privilege mode and enter `y` when prompted to continue: `set -priv advanced`
    - b. Enter the command to display the key management information: `security key-manager onboard show-backup`
    - c. Copy the contents of the backup information to a separate file or your log file. You'll need it in disaster scenarios where you might need to manually recover OKM.
    - d. Return to admin mode: `set -priv admin`
    - e. Shut down the impaired controller.
  3. If the Key Manager type displays `external` and the Restored column displays anything other than `yes`:
    - a. Restore the external key management authentication keys to all nodes in the cluster: `security key-manager external restore`  
  
If the command fails, contact NetApp Support.  
  
[mysupport.netapp.com](https://mysupport.netapp.com)
    - b. Verify that the Restored column equals `yes` for all authentication keys: `security key-manager key query`
    - c. Shut down the impaired controller.
  4. If the Key Manager type displays `onboard` and the Restored column displays anything other than `yes`:
    - a. Enter the onboard security key-manager sync command: `security key-manager onboard sync`  
  

 Enter the customer's 32 character, alphanumeric onboard key management passphrase at the prompt. If the passphrase cannot be provided, contact NetApp Support.  
[mysupport.netapp.com](https://mysupport.netapp.com)
    - b. Verify the Restored column shows `yes` for all authentication keys: `security key-manager key query`
    - c. Verify that the Key Manager type shows `onboard`, and then manually back up the OKM information.
    - d. Go to advanced privilege mode and enter `y` when prompted to continue: `set -priv advanced`
    - e. Enter the command to display the key management backup information: `security key-manager onboard show-backup`
    - f. Copy the contents of the backup information to a separate file or your log file. You'll need it in disaster scenarios where you might need to manually recover OKM.
    - g. Return to admin mode: `set -priv admin`
    - h. You can safely shut down the controller.

## Verify NSE configuration

1. Display the key IDs of the authentication keys that are stored on the key management servers: `security key-manager key query -key-type NSE-AK`



After the ONTAP 9.6 release, you may have additional key manager types. The types are KMIP, AKV, and GCP. The process for confirming these types is the same as confirming external or onboard key manager types.

- If the Key Manager type displays `external` and the Restored column displays `yes`, it's safe to shut down the impaired controller.
  - If the Key Manager type displays `onboard` and the Restored column displays `yes`, you need to complete some additional steps.
  - If the Key Manager type displays `external` and the Restored column displays anything other than `yes`, you need to complete some additional steps.
  - If the Key Manager type displays `external` and the Restored column displays anything other than `yes`, you need to complete some additional steps.
2. If the Key Manager type displays `onboard` and the Restored column displays `yes`, manually back up the OKM information:
    - a. Go to advanced privilege mode and enter `y` when prompted to continue: `set -priv advanced`
    - b. Enter the command to display the key management information: `security key-manager onboard show-backup`
    - c. Copy the contents of the backup information to a separate file or your log file. You'll need it in disaster scenarios where you might need to manually recover OKM.
    - d. Return to admin mode: `set -priv admin`
    - e. You can safely shut down the controller.
  3. If the Key Manager type displays `external` and the Restored column displays anything other than `yes`:
    - a. Restore the external key management authentication keys to all nodes in the cluster: `security key-manager external restore`  
  
If the command fails, contact NetApp Support.  
  
[mysupport.netapp.com](https://mysupport.netapp.com)
    - b. Verify that the Restored column equals `yes` for all authentication keys: `security key-manager key query`
    - c. You can safely shut down the controller.
  4. If the Key Manager type displays `onboard` and the Restored column displays anything other than `yes`:
    - a. Enter the onboard security key-manager sync command: `security key-manager onboard sync`  
  
Enter the customer's 32 character, alphanumeric onboard key management passphrase at the prompt. If the passphrase cannot be provided, contact NetApp Support.  
  
[mysupport.netapp.com](https://mysupport.netapp.com)

- b. Verify the `Restored` column shows `yes` for all authentication keys: `security key-manager key query`
- c. Verify that the `Key Manager` type shows `onboard`, and then manually back up the OKM information.
- d. Go to advanced privilege mode and enter `y` when prompted to continue: `set -priv advanced`
- e. Enter the command to display the key management backup information: `security key-manager onboard show-backup`
- f. Copy the contents of the backup information to a separate file or your log file. You'll need it in disaster scenarios where you might need to manually recover OKM.
- g. Return to admin mode: `set -priv admin`
- h. You can safely shut down the controller.

### Shut down the controller - ASA A250

Shut down or take over the impaired controller using the appropriate procedure for your configuration.

#### Option 1: Most systems

After completing the NVE or NSE tasks, you need to complete the shutdown of the impaired controller.

#### Steps

- a. Take the impaired controller to the LOADER prompt:

If the impaired controller displays...	Then...
The LOADER prompt	Go to Remove controller module.
<code>Waiting for giveback...</code>	Press <code>Ctrl-C</code> , and then respond <code>y</code> when prompted.
System prompt or password prompt (enter system password)	Take over or halt the impaired controller from the healthy controller: <code>storage failover takeover -ofnode impaired_node_name</code>  When the impaired controller shows <code>Waiting for giveback...</code> , press <code>Ctrl-C</code> , and then respond <code>y</code> .

- b. From the LOADER prompt, enter: `printenv` to capture all boot environmental variables. Save the output to your log file.



This command may not work if the boot device is corrupted or non-functional.

#### Option 2: Systems in a MetroCluster

After completing the NVE or NSE tasks, you need to complete the shutdown of the impaired controller.



Do not use this procedure if your system is in a two-node MetroCluster configuration.

To shut down the impaired controller, you must determine the status of the controller and, if necessary, take over the controller so that the healthy controller continues to serve data from the impaired controller storage.

- If you have a cluster with more than two nodes, it must be in quorum. If the cluster is not in quorum or a healthy controller shows false for eligibility and health, you must correct the issue before shutting down the impaired controller; see [Synchronize a node with the cluster](#).
- If you have a MetroCluster configuration, you must have confirmed that the MetroCluster Configuration State is configured and that the nodes are in an enabled and normal state (`metrocluster node show`).

### Steps

1. If AutoSupport is enabled, suppress automatic case creation by invoking an AutoSupport message:

```
system node autosupport invoke -node * -type all -message
MAINT=number_of_hours_downh
```

The following AutoSupport message suppresses automatic case creation for two hours: `cluster1:*>`

```
system node autosupport invoke -node * -type all -message MAINT=2h
```

2. Disable automatic giveback from the console of the healthy controller: `storage failover modify -node local -auto-giveback false`
3. Take the impaired controller to the LOADER prompt:

If the impaired controller is displaying...	Then...
The LOADER prompt	Go to the next step.
Waiting for giveback...	Press Ctrl-C, and then respond <code>y</code> when prompted.
System prompt or password prompt (enter system password)	Take over or halt the impaired controller from the healthy controller: <pre>storage failover takeover -ofnode impaired_node_name</pre> <p>When the impaired controller shows Waiting for giveback..., press Ctrl-C, and then respond <code>y</code>.</p>

## Replace the boot media - ASA A250

To replace the boot media, you must remove the impaired controller module, install the replacement boot media, and transfer the boot image to a USB flash drive.

### Step 1: Remove the controller module

To access components inside the controller module, you must first remove the controller module from the system, and then remove the cover on the controller module.

### Steps

1. If you are not already grounded, properly ground yourself.

2. Unplug the controller module power supplies from the source.
3. Release the power cable retainers, and then unplug the cables from the power supplies.
4. Insert your forefinger into the latching mechanism on either side of the controller module, press the lever with your thumb, and gently pull the controller a few inches out of the chassis.



If you have difficulty removing the controller module, place your index fingers through the finger holes from the inside (by crossing your arms).

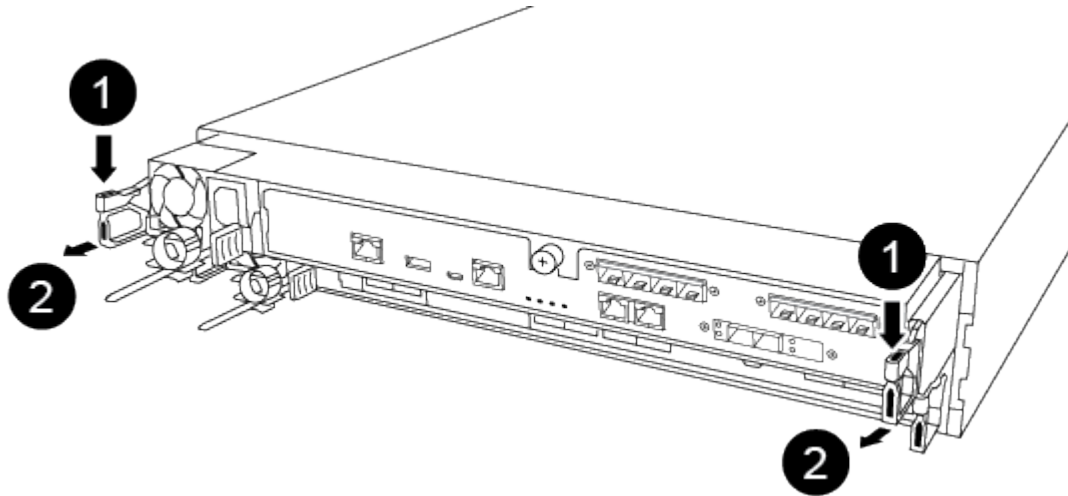

<b>1</b>	Lever
<b>2</b>	Latching mechanism

5. Using both hands, grasp the controller module sides and gently pull it out of the chassis and set it on a flat, stable surface.
6. Turn the thumbscrew on the front of the controller module anti-clockwise and open the controller module cover.

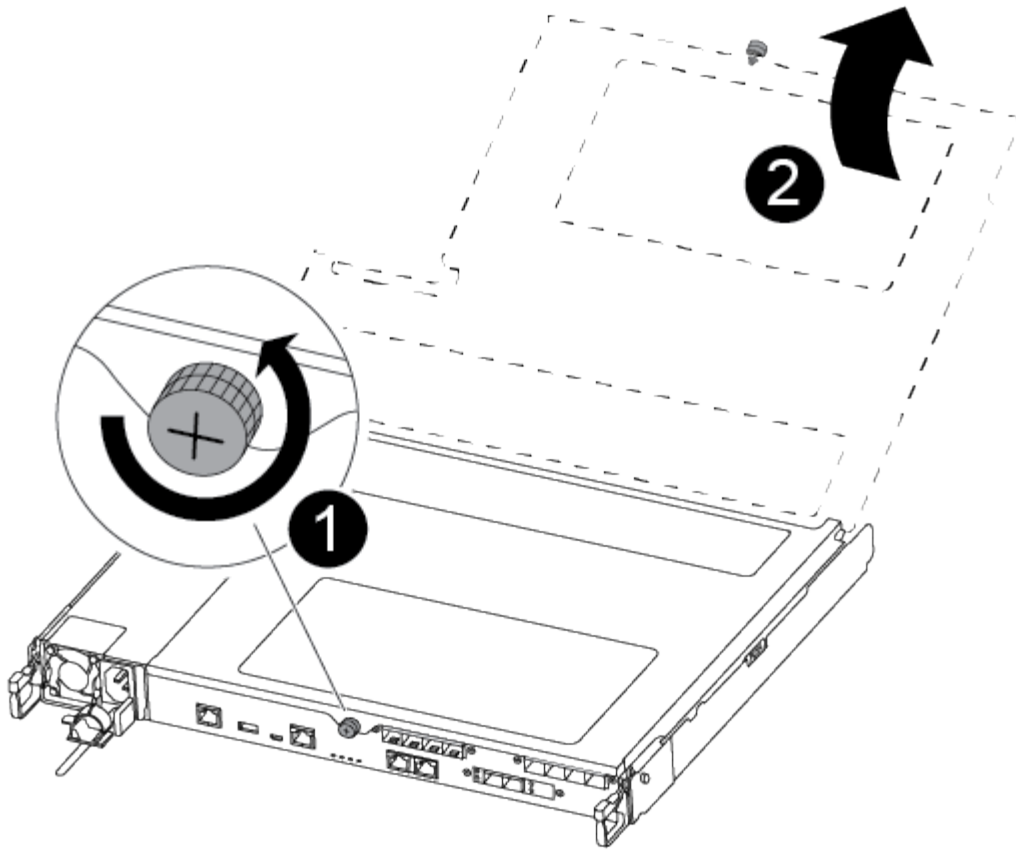

1	Thumbscrew
2	Controller module cover.

7. Lift out the air duct cover.

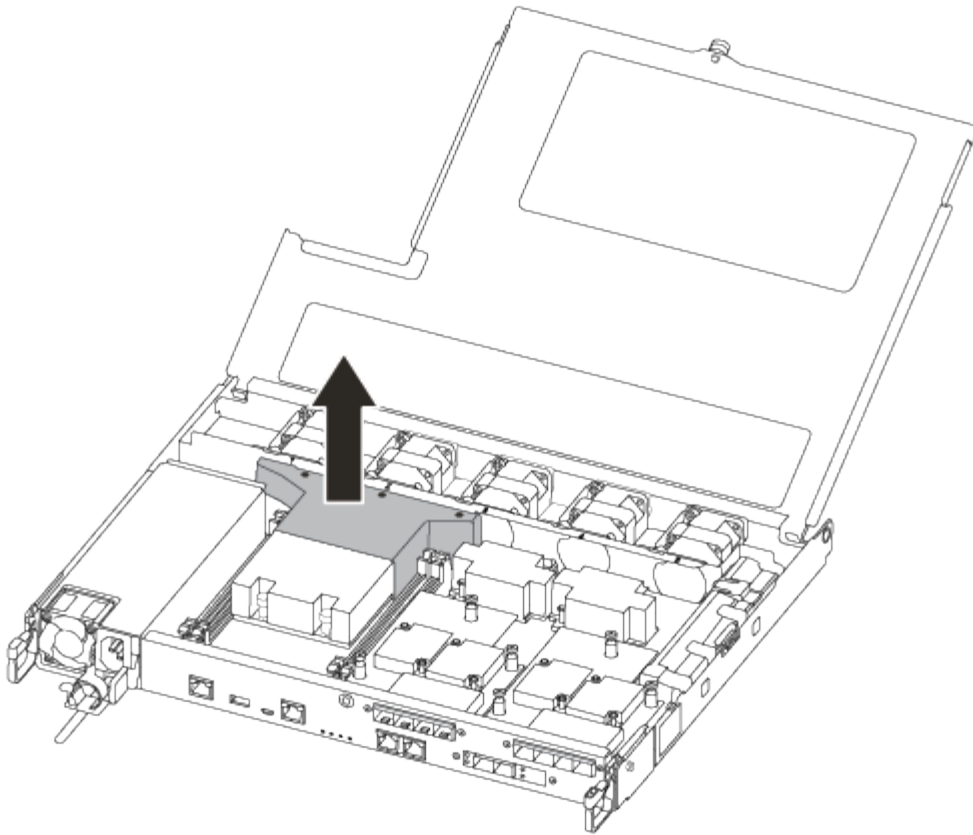

## Step 2: Replace the boot media

You locate the failed boot media in the controller module by removing the air duct on the controller module before you can replace the boot media.

You need a #1 magnetic Phillips head screwdriver to remove the screw that holds the boot media in place. Due to the space constraints within the controller module, you should also have a magnet to transfer the screw on to so that you do not lose it.

You can use the following video or the tabulated steps to replace the boot media:

[Animation - Replace the boot media](#)

1. Locate and replace the impaired boot media from the controller module.



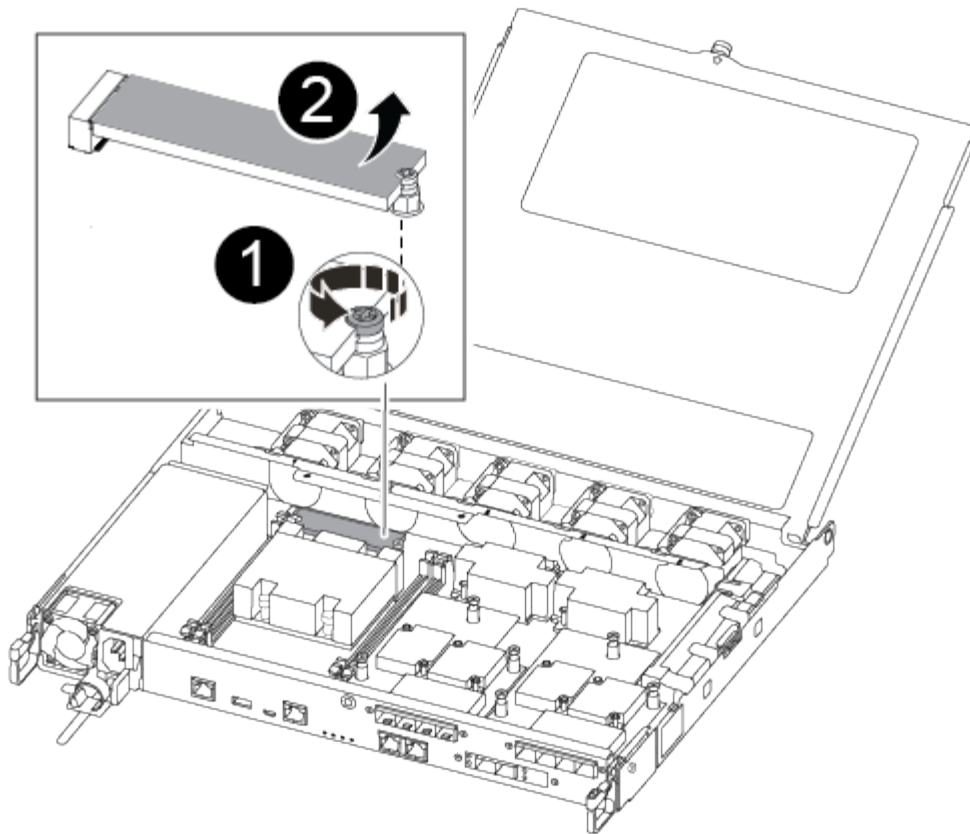

<p><b>1</b></p>	<p>Remove the screw securing the boot media to the motherboard in the controller module.</p>
<p><b>2</b></p>	<p>Lift the boot media out of the controller module.</p>

2. Using the #1 magnetic screwdriver, remove the screw from the impaired boot media, and set it aside safely on the magnet.
3. Gently lift the impaired boot media directly out of the socket and set it aside.
4. Remove the replacement boot media from the antistatic shipping bag and align it into place on the controller module.
5. Using the #1 magnetic screwdriver, insert and tighten the screw on the boot media.



Do not apply force when tightening the screw on the boot media; you might crack it.

### Step 3: Transfer the boot image to the boot media

The replacement boot media that you installed is without a boot image so you need to transfer a boot image using a USB flash drive.

- You must have a USB flash drive, formatted to MBR/FAT32, with at least 4GB capacity
- A copy of the same image version of ONTAP as what the impaired controller was running. You can download the appropriate image from the Downloads section on the NetApp Support Site
  - If NVE is enabled, download the image with NetApp Volume Encryption, as indicated in the download

button.

- If NVE is not enabled, download the image without NetApp Volume Encryption, as indicated in the download button.
- If your system is an HA pair, you must have a network connection.
- If your system is a stand-alone system you do not need a network connection, but you must perform an additional reboot when restoring the var file system.

1. Download and copy the appropriate service image from the NetApp Support Site to the USB flash drive.
2. Download the service image to your work space on your laptop.
3. Unzip the service image.



If you are extracting the contents using Windows, do not use winzip to extract the netboot image. Use another extraction tool, such as 7-Zip or WinRAR.

There are two folders in the unzipped service image file:

- boot
  - efi
4. Copy the efi folder to the top directory on the USB flash drive.

The USB flash drive should have the efi folder and the same Service Image (BIOS) version of what the impaired controller is running.

5. Remove the USB flash drive from your laptop.
6. If you have not already done so, install the air duct.

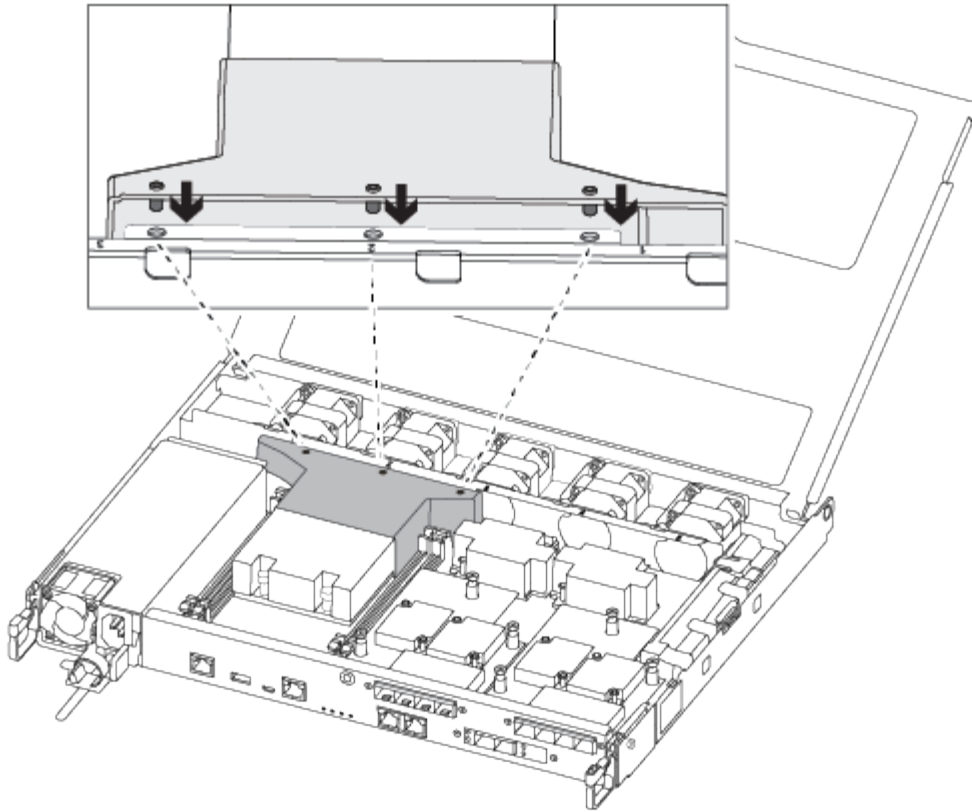

7. Close the controller module cover and tighten the thumbscrew.

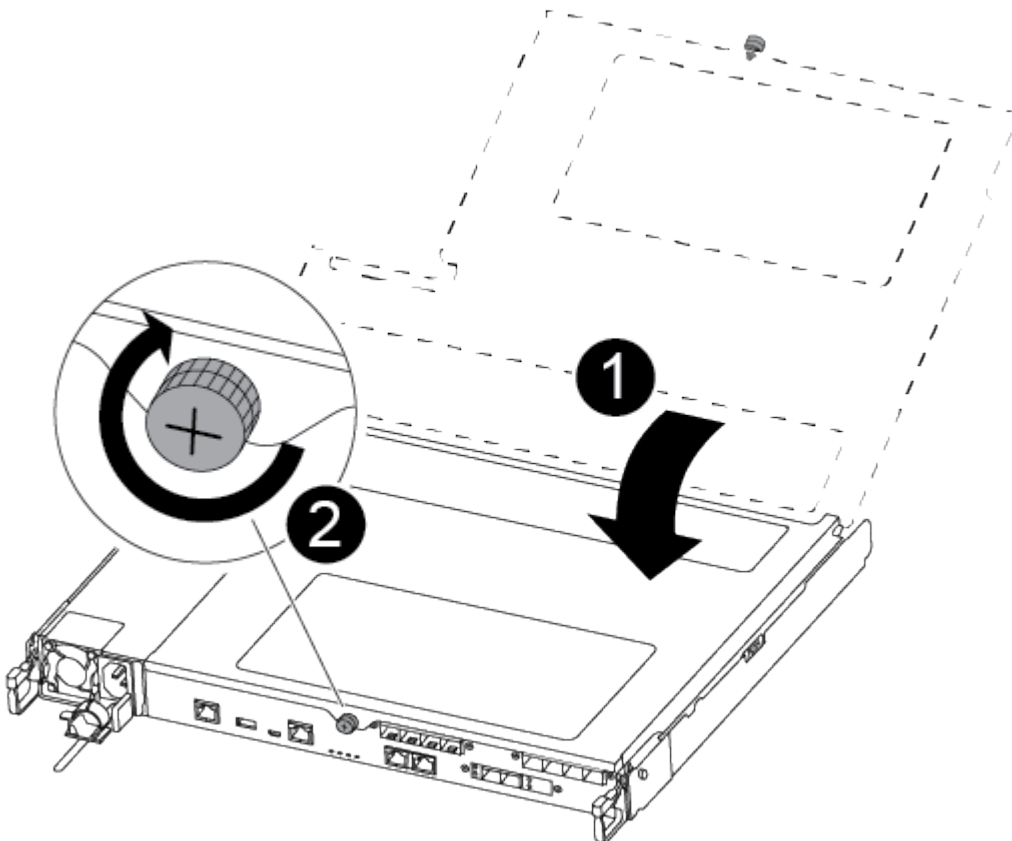

<b>1</b>	Controller module cover
<b>2</b>	Thumbscrew

8. Align the end of the controller module with the opening in the chassis, and then gently push the controller module halfway into the system.
9. Plug the power cable into the power supply and reinstall the power cable retainer.
10. Insert the USB flash drive into the USB slot on the controller module.

Make sure that you install the USB flash drive in the slot labeled for USB devices, and not in the USB console port.

11. Push the controller module all the way into the chassis:
12. Place your index fingers through the finger holes from the inside of the latching mechanism.
13. Press your thumbs down on the orange tabs on top of the latching mechanism and gently push the controller module over the stop.
14. Release your thumbs from the top of the latching mechanisms and continue pushing until the latching mechanisms snap into place.

The controller module begins to boot as soon as it is fully seated in the chassis. Be prepared to interrupt the boot process.

The controller module should be fully inserted and flush with the edges of the chassis.

15. Interrupt the boot process to stop at the LOADER prompt by pressing Ctrl-C when you see Starting AUTOBOOT press Ctrl-C to abort....

If you miss this message, press Ctrl-C, select the option to boot to Maintenance mode, and then halt the controller to boot to LOADER.

16. For systems with one controller in the chassis, reconnect the power and turn on the power supplies.

The system begins to boot and stops at the LOADER prompt.

17. Set your network connection type at the LOADER prompt:

- If you are configuring DHCP: `ifconfig e0a -auto`



The target port you configure is the target port you use to communicate with the impaired controller from the healthy controller during var file system restore with a network connection. You can also use the e0M port in this command.

- If you are configuring manual connections: `ifconfig e0a -addr=filer_addr -mask=netmask -gw=gateway-dns=dns_addr-domain=dns_domain`
  - `filer_addr` is the IP address of the storage system.
  - `netmask` is the network mask of the management network that is connected to the HA partner.
  - `gateway` is the gateway for the network.

- `dns_addr` is the IP address of a name server on your network.
- `dns_domain` is the Domain Name System (DNS) domain name.

If you use this optional parameter, you do not need a fully qualified domain name in the netboot server URL. You need only the server's host name.



Other parameters might be necessary for your interface. You can enter `help ifconfig` at the firmware prompt for details.

### Boot the recovery image - ASA A250

You must boot the ONTAP image from the USB drive, restore the file system, and verify the environmental variables.

1. From the LOADER prompt, boot the recovery image from the USB flash drive: `boot_recovery`

The image is downloaded from the USB flash drive.

2. When prompted, either enter the name of the image or accept the default image displayed inside the brackets on your screen.
3. Restore the `var` file system:

If your system has...	Then...
A network connection	<ol style="list-style-type: none"> <li>a. Press <code>y</code> when prompted to restore the backup configuration.</li> <li>b. Set the healthy controller to advanced privilege level: <code>set -privilege advanced</code></li> <li>c. Run the restore backup command: <code>system node restore-backup -node local -target-address <i>impaired_node_IP_address</i></code></li> <li>d. Return the controller to admin level: <code>set -privilege admin</code></li> <li>e. Press <code>y</code> when prompted to use the restored configuration.</li> <li>f. Press <code>y</code> when prompted to reboot the controller.</li> </ol>
No network connection	<ol style="list-style-type: none"> <li>a. Press <code>n</code> when prompted to restore the backup configuration.</li> <li>b. Reboot the system when prompted by the system.</li> <li>c. Select the <b>Update flash from backup config</b> (sync flash) option from the displayed menu.</li> </ol> <p>If you are prompted to continue with the update, press <code>y</code>.</p>

If your system has...	Then...
No network connection and is in a MetroCluster IP configuration	<p>a. Press <code>n</code> when prompted to restore the backup configuration.</p> <p>b. Reboot the system when prompted by the system.</p> <p>c. Wait for the iSCSI storage connections to connect.</p> <p>You can proceed after you see the following messages:</p> <pre data-bbox="672 394 1484 1255"> date-and-time [node- name:iscsi.session.stateChanged:notice]: iSCSI session state is changed to Connected for the target iSCSI-target (type: dr_auxiliary, address: ip-address). date-and-time [node- name:iscsi.session.stateChanged:notice]: iSCSI session state is changed to Connected for the target iSCSI-target (type: dr_partner, address: ip-address). date-and-time [node- name:iscsi.session.stateChanged:notice]: iSCSI session state is changed to Connected for the target iSCSI-target (type: dr_auxiliary, address: ip-address). date-and-time [node- name:iscsi.session.stateChanged:notice]: iSCSI session state is changed to Connected for the target iSCSI-target (type: dr_partner, address: ip-address). </pre> <p>d. Select the <b>Update flash from backup config</b> (sync flash) option from the displayed menu.</p> <p>If you are prompted to continue with the update, press <code>y</code>.</p>

4. Ensure that the environmental variables are set as expected:

- a. Take the controller to the `LOADER` prompt.
- b. Check the environment variable settings with the `printenv` command.
- c. If an environment variable is not set as expected, modify it with the `setenv environment_variable_name changed_value` command.
- d. Save your changes using the `saveenv` command.

5. The next depends on your system configuration:

- If your system has onboard keymanager, NSE or NVE configured, go to [Restore OKM, NSE, and NVE as needed](#)

- If your system does not have onboard keymanager, NSE or NVE configured, complete the steps in this section.

6. From the LOADER prompt, enter the `boot_ontap` command.

If you see...	Then...
The login prompt	Go to the next Step.
Waiting for giveback...	<ol style="list-style-type: none"> <li>Log into the partner controller.</li> <li>Confirm the target controller is ready for giveback with the <code>storage failover show</code> command.</li> </ol>

- Connect the console cable to the partner controller.
- Give back the controller using the `storage failover giveback -fromnode local` command.
- At the cluster prompt, check the logical interfaces with the `net int -is-home false` command.

If any interfaces are listed as "false", revert those interfaces back to their home port using the `net int revert` command.

- Move the console cable to the repaired controller and run the `version -v` command to check the ONTAP versions.
- Restore automatic giveback if you disabled it by using the `storage failover modify -node local -auto-giveback true` command.

### Restore OKM, NSE, and NVE as needed - ASA A250

Once environment variables are checked, you must complete steps specific to systems that have Onboard Key Manager (OKM), NetApp Storage Encryption (NSE) or NetApp Volume Encryption (NVE) enabled.

- Determine which section you should use to restore your OKM, NSE, or NVE configurations: If NSE or NVE are enabled along with Onboard Key Manager you must restore settings you captured at the beginning of this procedure.
  - If NSE or NVE are enabled and Onboard Key Manager is enabled, go to [Restore NVE or NSE when Onboard Key Manager is enabled](#).
  - If NSE or NVE are enabled for ONTAP 9.6, go to [Restore NSE/NVE on systems running ONTAP 9.6 and later](#).

### Restore NVE or NSE when Onboard Key Manager is enabled

#### Steps

- Connect the console cable to the target controller.
- Use the `boot_ontap` command at the LOADER prompt to boot the controller.
- Check the console output:

If the console displays...	Then...
The LOADER prompt	Boot the controller to the boot menu: <code>boot_ontap menu</code>
Waiting for giveback....	<ol style="list-style-type: none"> <li>Enter <code>Ctrl-C</code> at the prompt</li> <li>At the message: Do you wish to halt this node rather than wait [y/n]? , enter: <code>y</code></li> <li>At the LOADER prompt, enter the <code>boot_ontap menu</code> command.</li> </ol>

- At the Boot Menu, enter the hidden command, `recover_onboard_keymanager` and reply `y` at the prompt
- Enter the passphrase for the onboard key manager you obtained from the customer at the beginning of this procedure.
- When prompted to enter the backup data, paste the backup data you captured at the beginning of this procedure, when asked. Paste the output of `security key-manager backup show` OR `security key-manager onboard show-backup` command



The data is output from either `security key-manager backup show` or `security key-manager onboard show-backup` command.

Example of backup data:

```

-----BEGIN BACKUP-----
TmV0QXBwIEtleSBCbG9iAAEAAAAEAAAAcAEAAAAAADuD+byAAAAACEAAAAAAAAA
QAAAAAAAAABvOIH0AAAAAMh7qDLRyH1DBz12piVdy9ATSFMT0C0TIYFss4PDjTaV
dzRYkLd1PhQLxAWJwOlyqSr8qY1SEBgm1IWgE5DLRqkiAAAAAAAACgAAAAAAAA
3WTh7gAAAAAAAAAAAAAAAAAIAAAAAAAgAZJEIWvdeHr5RCAvHGclo+wAAAAAAAA
lgAAAAAAAAAoAAAAAAAAAEOTcR0AAAAAAAAAAAAAAAAAAAAAAAJAGr3tJA/
LRzUQRHwv+1aWvAAAAAAAAAACQAAAAAAAAAgAAAAAAAAACdhTcvAAAAAJ1PXeBf
ml4NBsSyV1B4jc4A7cvWEFY6ILG6hc6tbKLAHZuvfQ4rlbYAAAAAAAAAAAAAAAA
AAAAAAAAAAAAAAAAAAAAAAAAAAAAAAAAAAAAAAAAAAAAAAAAAAAAAAAAAAAAAA
AAAAAAAAAAAAAAAAAAAAAAAAAAAAAAAAAAAAAAAAAAAAAAAAAAAAAAAAAAAAAA
.
.
.
.
H4nPQM0nrDRYRa9SCv8AAAAAAAAAAAAAAAAAAAAAAAAAAAAAAAAAAAAAAAAAAAA
AAAAAAAAAAAAAAAAAAAAAAAAAAAAAAAAAAAAAAAAAAAAAAAAAAAAAAAAAAAAAA
AAAAAAA
-----END BACKUP-----

```

- At the Boot Menu select the option for Normal Boot.  
The system boots to Waiting for giveback... prompt.
- Confirm the target controller is ready for giveback with the `storage failover show` command.



9. Giveback only the CFO aggregates with the `storage failover giveback -fromnode local -only-cfo-aggregates true` command.
  - If the command fails because of a failed disk, physically disengage the failed disk, but leave the disk in the slot until a replacement is received.
  - If the command fails because of an open CIFS sessions, check with customer how to close out CIFS sessions.



Terminating CIFS can cause loss of data.

- If the command fails because the partner "not ready", wait 5 minutes for the NVMEMs to synchronize.
  - If the command fails because of an NDMP, SnapMirror, or SnapVault process, disable the process. See the appropriate Documentation Center for more information.
10. Once the giveback completes, check the failover and giveback status with the `storage failover show` and ``storage failover show-giveback`` commands.

Only the CFO aggregates (root aggregate and CFO style data aggregates) will be shown.

11. Move the console cable to the target controller.
  - a. If you are running ONTAP 9.6 or later, run the security key-manager onboard sync:
  - b. Run the `security key-manager onboard sync` command and then enter the passphrase when prompted.
  - c. Enter the `security key-manager key query` command to see a detailed view of all keys stored in the onboard key manager and verify that the `Restored` column = `yes/true` for all authentication keys.



If the `Restored` column = anything other than `yes/true`, contact Customer Support.

- d. Wait 10 minutes for the key to synchronize across the cluster.
12. Move the console cable to the partner controller.
13. Give back the target controller using the `storage failover giveback -fromnode local` command.
14. Check the giveback status, 3 minutes after it reports complete, using the `storage failover show` command.

If giveback is not complete after 20 minutes, contact Customer Support.

15. At the clustershell prompt, enter the `net int show -is-home false` command to list the logical interfaces that are not on their home controller and port.

If any interfaces are listed as `false`, revert those interfaces back to their home port using the `net int revert -vserver Cluster -lif nodename` command.

16. Move the console cable to the target controller and run the `version -v` command to check the ONTAP versions.
17. Restore automatic giveback if you disabled it by using the `storage failover modify -node local -auto-giveback true` command.

## Restore NSE/NVE on systems running ONTAP 9.6 and later

### Steps

1. Connect the console cable to the target controller.
2. Use the `boot_ontap` command at the LOADER prompt to boot the controller.
3. Check the console output:

If the console displays...	Then...
The login prompt	Go to Step 7.
Waiting for giveback...	<ol style="list-style-type: none"><li>a. Log into the partner controller.</li><li>b. Confirm the target controller is ready for giveback with the <code>storage failover show</code> command.</li></ol>

4. Move the console cable to the partner controller and give back the target controller storage using the `storage failover giveback -fromnode local -only-cfo-aggregates true local` command.
  - If the command fails because of a failed disk, physically disengage the failed disk, but leave the disk in the slot until a replacement is received.
  - If the command fails because of an open CIFS sessions, check with customer how to close out CIFS sessions.



Terminating CIFS can cause loss of data.

- If the command fails because the partner "not ready", wait 5 minutes for the NVMEMs to synchronize.
  - If the command fails because of an NDMP, SnapMirror, or SnapVault process, disable the process. See the appropriate Documentation Center for more information.
5. Wait 3 minutes and check the failover status with the `storage failover show` command.
  6. At the clustershell prompt, enter the `net int show -is-home false` command to list the logical interfaces that are not on their home controller and port.

If any interfaces are listed as `false`, revert those interfaces back to their home port using the `net int revert -vserver Cluster -lif nodename` command.
  7. Move the console cable to the target controller and run the `version -v` command to check the ONTAP versions.
  8. Restore automatic giveback if you disabled it by using the `storage failover modify -node local -auto-giveback true` command.
  9. Use the `storage encryption disk show` at the clustershell prompt, to review the output.
  10. Use the `security key-manager key query` command to display the key IDs of the authentication keys that are stored on the key management servers.
    - If the `Restored` column = `yes/true`, you are done and can proceed to complete the replacement process.

- If the `Key Manager type = external` and the `Restored` column = anything other than `yes/true`, use the `security key-manager external restore` command to restore the key IDs of the authentication keys.



If the command fails, contact Customer Support.

- If the `Key Manager type = onboard` and the `Restored` column = anything other than `yes/true`, use the `security key-manager onboard sync` command to re-sync the Key Manager type.

Use the `security key-manager key query` command to verify that the `Restored` column = `yes/true` for all authentication keys.

11. Connect the console cable to the partner controller.
12. Give back the controller using the `storage failover giveback -fromnode local` command.
13. Restore automatic giveback if you disabled it by using the `storage failover modify -node local -auto-giveback true` command.

### Return the failed part to NetApp - ASA A250

Return the failed part to NetApp, as described in the RMA instructions shipped with the kit. See the [Part Return and Replacements](#) page for further information.

### Chassis

#### Overview of chassis replacement - ASA A250

To replace the chassis, you must move the bezel, controller modules, and NVMe drives from the impaired chassis to the replacement chassis, and then remove the impaired chassis from the equipment rack or system cabinet and install the replacement chassis in its place.

#### About this task

- All other components in the system must be functioning properly; if not, you must contact technical support.
- You can use this procedure with all versions of ONTAP supported by your system.
- This procedure is written with the assumption that you are moving the bezel, NVMe drives, and controller modules to the new chassis, and that the replacement chassis is a new component from NetApp.
- This procedure is disruptive. For a two-node cluster, you will have a complete service outage and a partial outage in a multi-node cluster.

#### Shut down the controllers - ASA A250

This procedure is for 2-node, non-MetroCluster configurations only. If you have a system with more than two nodes, see [How to perform a graceful shutdown and power up of one HA pair in a 4-node cluster](#).

#### Before you begin

You need:

- Local administrator credentials for ONTAP.
- NetApp onboard key management (OKM) cluster-wide passphrase if using storage encryption or NVE/NAE.
- BMC accessibility for each controller.
- Stop all clients/host from accessing data on the NetApp system.
- Suspend external backup jobs.
- Necessary tools and equipment for the replacement.



If the system is a NetApp StorageGRID or ONTAP S3 used as FabricPool cloud tier, refer to the [Gracefully shutdown and power up your storage system Resolution Guide](#) after performing this procedure.



If using SSDs, refer to [SU490: \(Impact: Critical\) SSD Best Practices: Avoid risk of drive failure and data loss if powered off for more than two months](#)

As a best practice before shutdown, you should:

- Perform additional [system health checks](#).
- Upgrade ONTAP to a recommended release for the system.
- Resolve any [Active IQ Wellness Alerts and Risks](#).  
Make note of any faults presently on the system, such as LEDs on the system components.

### Steps

1. Log into the cluster through SSH or log in from any node in the cluster using a local console cable and a laptop/console.
2. Turn off AutoSupport and indicate how long you expect the system to be offline:

```
system node autosupport invoke -node * -type all -message "MAINT=8h Power Maintenance"
```

3. Identify the SP/BMC address of all nodes:

```
system service-processor show -node * -fields address
```

4. Exit the cluster shell: `exit`
5. Log into SP/BMC over SSH using the IP address of any of the nodes listed in the output from the previous step.

If you're using a console/laptop, log into the controller using the same cluster administrator credentials.



Open an SSH session to every SP/BMC connection so that you can monitor progress.

6. Halt the 2 nodes located in the impaired chassis:

```
system node halt -node <node>,<node2> -skip-lif-migration-before-shutdown true -ignore-quorum-warnings true -inhibit-takeover true
```



For clusters using SnapMirror synchronous operating in StrictSync mode: `system node halt -node <node>, <node2> -skip-lif-migration-before-shutdown true -ignore-quorum-warnings true -inhibit-takeover true -ignore-strict-sync-warnings true`

7. Enter **y** for each controller in the cluster when you see *Warning: Are you sure you want to halt node "cluster <node-name> number"?*  
{y|n}:
8. Wait for each controller to halt and display the LOADER prompt.

## Replace chassis - ASA A250

To replace the chassis, you move the power supplies, hard drives, and controller module from the impaired chassis to the new chassis, and swap out the impaired chassis from with the new chassis of the same model as the impaired chassis.

### Step 1: Remove the controller modules

To replace the chassis, you must remove the controller modules from the old chassis.

Use the following video or the tabulated steps to replace the chassis; it assumes the removal and replacement of the bezel:

#### [Animation - Replace the chassis](#)

1. If you are not already grounded, properly ground yourself.
2. Unplug the controller module power supplies from the source.
3. Release the power cable retainers, and then unplug the cables from the power supplies.
4. Insert your forefinger into the latching mechanism on either side of the controller module, press the lever with your thumb, and gently pull the controller a few inches out of the chassis.



If you have difficulty removing the controller module, place your index fingers through the finger holes from the inside (by crossing your arms).

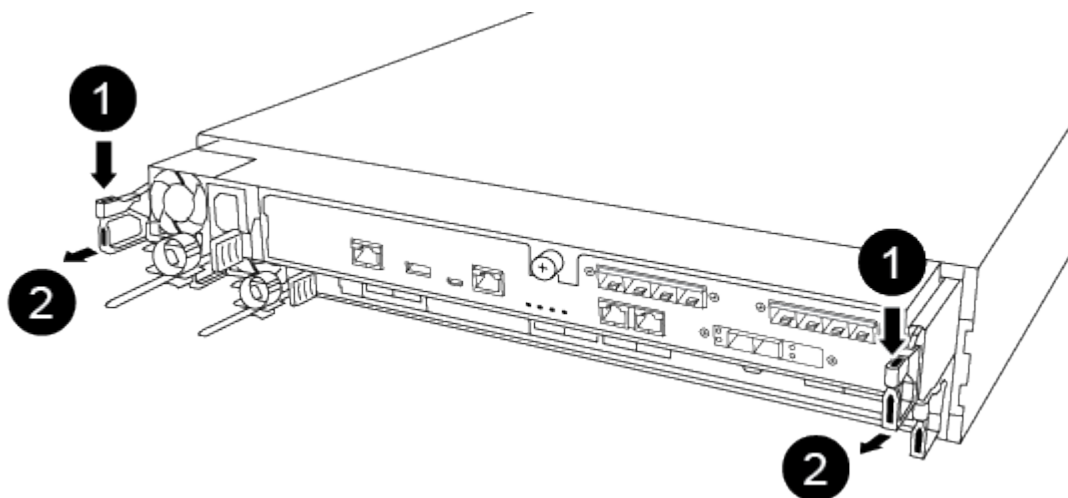

<b>1</b>	Lever
<b>2</b>	Latching mechanism

5. Using both hands, grasp the controller module sides and gently pull it out of the chassis and set it on a flat, stable surface.
6. Set the controller module aside in a safe place, and repeat these steps for the other controller module in the chassis.

## Step 2: Move drives to the new chassis

You need to move the drives from each bay opening in the old chassis to the same bay opening in the new chassis.

1. Gently remove the bezel from the front of the system.
2. Remove the drives:
  - a. Press the release button at the top of the carrier face below the LEDs.
  - b. Pull the cam handle to its fully open position to unseat the drive from the midplane, and then gently slide the drive out of the chassis.

The drive should disengage from the chassis, allowing it to slide free of the chassis.



When removing a drive, always use two hands to support its weight.



Drives are fragile. Handle them as little as possible to prevent damage to them.

3. Align the drive from the old chassis with the same bay opening in the new chassis.
4. Gently push the drive into the chassis as far as it will go.

The cam handle engages and begins to rotate upward.

5. Firmly push the drive the rest of the way into the chassis, and then lock the cam handle by pushing it up and against the drive holder.

Be sure to close the cam handle slowly so that it aligns correctly with the front of the drive carrier. It clicks when it is secure.

6. Repeat the process for the remaining drives in the system.

## Step 3: Replace a chassis from within the equipment rack or system cabinet

You must remove the existing chassis from the equipment rack or system cabinet before you can install the replacement chassis.

1. Remove the screws from the chassis mount points.
2. With two people, slide the old chassis off the rack rails in a system cabinet or equipment rack, and then set it aside.

3. If you are not already grounded, properly ground yourself.
4. Using two people, install the replacement chassis into the equipment rack or system cabinet by guiding the chassis onto the rack rails in a system cabinet or equipment rack.
5. Slide the chassis all the way into the equipment rack or system cabinet.
6. Secure the front of the chassis to the equipment rack or system cabinet, using the screws you removed from the old chassis.
7. If you have not already done so, install the bezel.

#### Step 4: Install the controller modules

After you install the controller modules into the new chassis, you need to boot the system.

For HA pairs with two controller modules in the same chassis, the sequence in which you install the controller module is especially important because it attempts to reboot as soon as you completely seat it in the chassis.

1. Align the end of the controller module with the opening in the chassis, and then gently push the controller module halfway into the system.



Do not completely insert the controller module in the chassis until instructed to do so.

2. Recable the console to the controller module, and then reconnect the management port.
3. Plug the power cables into the power supplies and reinstall the power cable retainers.
4. Insert the controller module into the chassis:
  - a. Ensure the latching mechanism arms are locked in the fully extended position.
  - b. Using both hands, align and gently slide the controller module into the latching mechanism arms until it stops.
  - c. Place your index fingers through the finger holes from the inside of the latching mechanism.
  - d. Press your thumbs down on the orange tabs on top of the latching mechanism and gently push the controller module over the stop.
  - e. Release your thumbs from the top of the latching mechanisms and continue pushing until the latching mechanisms snap into place.

The controller module begins to boot as soon as it is fully seated in the chassis. Be prepared to interrupt the boot process.

The controller module should be fully inserted and flush with the edges of the chassis.

5. Repeat the preceding steps to install the second controller into the new chassis.

#### Complete the restoration and replacement process - ASA A250

You must verify the HA state of the chassis, and return the failed part to NetApp, as described in the RMA instructions shipped with the kit.

#### Step 1: Verify and set the HA state of the chassis

You must verify the HA state of the chassis, and, if necessary, update the state to match your system configuration.

1. In Maintenance mode, from either controller module, display the HA state of the local controller module and chassis: `ha-config show`

The HA state should be the same for all components.

2. If the displayed system state for the chassis does not match your system configuration:

- a. Set the HA state for the chassis: `ha-config modify chassis HA-state`

The value for HA-state can be one of the following:

- `ha`
- `mcc`
- `mccip`
- `non-ha`

- b. Confirm that the setting has changed: `ha-config show`

3. If you have not already done so, recable the rest of your system.
4. Reinstall the bezel on the front of the system.

## Step 2: Return the failed part to NetApp

Return the failed part to NetApp, as described in the RMA instructions shipped with the kit. See the [Part Return and Replacements](#) page for further information.

### Controller

#### Overview of controller module replacement- ASA A250

You must review the prerequisites for the replacement procedure and select the correct one for your version of the ONTAP operating system.

- All drive shelves must be working properly.
- If your system is in a MetroCluster configuration, you must review the section [Choosing the correct recovery procedure](#) to determine whether you should use this procedure.
- You must replace the failed component with a replacement FRU component you received from your provider.
- You must be replacing a controller module with a controller module of the same model type. You cannot upgrade your system by just replacing the controller module.
- You cannot change any drives or drive shelves as part of this procedure.
- In this procedure, the boot device is moved from the impaired controller to the *replacement* controller so that the *replacement* controller will boot up in the same version of ONTAP as the old controller module.
- It is important that you apply the commands in these steps on the correct systems:
  - The *impaired* controller is the controller that is being replaced.
  - The *replacement* controller is the new controller that is replacing the impaired controller.
  - The *healthy* controller is the surviving controller.
- You must always capture the controller's console output to a text file.



This provides you a record of the procedure so that you can troubleshoot any issues that you might encounter during the replacement process.

## Shut down the impaired controller module - ASA A250

To shut down the impaired controller, you must determine the status of the controller and, if necessary, take over the controller so that the healthy controller continues to serve data from the impaired controller storage.

### About this task

- If you have a SAN system, you must have checked event messages (`cluster kernel-service show`) for the impaired controller SCSI blade. The `cluster kernel-service show` command (from `priv advanced` mode) displays the node name, quorum status of that node, availability status of that node, and operational status of that node.

Each SCSI-blade process should be in quorum with the other nodes in the cluster. Any issues must be resolved before you proceed with the replacement.

- If you have a cluster with more than two nodes, it must be in quorum. If the cluster is not in quorum or a healthy controller shows false for eligibility and health, you must correct the issue before shutting down the impaired controller; see [Synchronize a node with the cluster](#).

### Steps

1. If AutoSupport is enabled, suppress automatic case creation by invoking an AutoSupport message:  
`system node autosupport invoke -node * -type all -message MAINT=<# of hours>h`

The following AutoSupport message suppresses automatic case creation for two hours: `cluster1:> system node autosupport invoke -node * -type all -message MAINT=2h`

2. Disable automatic giveback from the console of the healthy controller: `storage failover modify -node local -auto-giveback false`



When you see *Do you want to disable auto-giveback?*, enter *y*.

3. Take the impaired controller to the LOADER prompt:

If the impaired controller is displaying...	Then...
The LOADER prompt	Go to the next step.
Waiting for giveback...	Press Ctrl-C, and then respond <i>y</i> when prompted.
System prompt or password prompt	Take over or halt the impaired controller from the healthy controller: <code>storage failover takeover -ofnode impaired_node_name</code>  When the impaired controller shows Waiting for giveback..., press Ctrl-C, and then respond <i>y</i> .

## Replace controller - ASA A250

To replace the controller module hardware, you must remove the impaired controller, move FRU components to the replacement controller module, install the replacement controller module in the chassis, and then boot the system to Maintenance mode.

### Step 1: Remove the controller module

You must remove the controller module from the chassis when you replace a component inside the controller module.

Make sure that you label the cables so that you know where they came from.

Use the following video or the tabulated steps to replace a controller module:

#### [Animation - Replace a controller module](#)

1. If you are not already grounded, properly ground yourself.
2. Unplug the controller module power supplies from the source.
3. Release the power cable retainers, and then unplug the cables from the power supplies.
4. Insert your forefinger into the latching mechanism on either side of the controller module, press the lever with your thumb, and gently pull the controller a few inches out of the chassis.



If you have difficulty removing the controller module, place your index fingers through the finger holes from the inside (by crossing your arms).

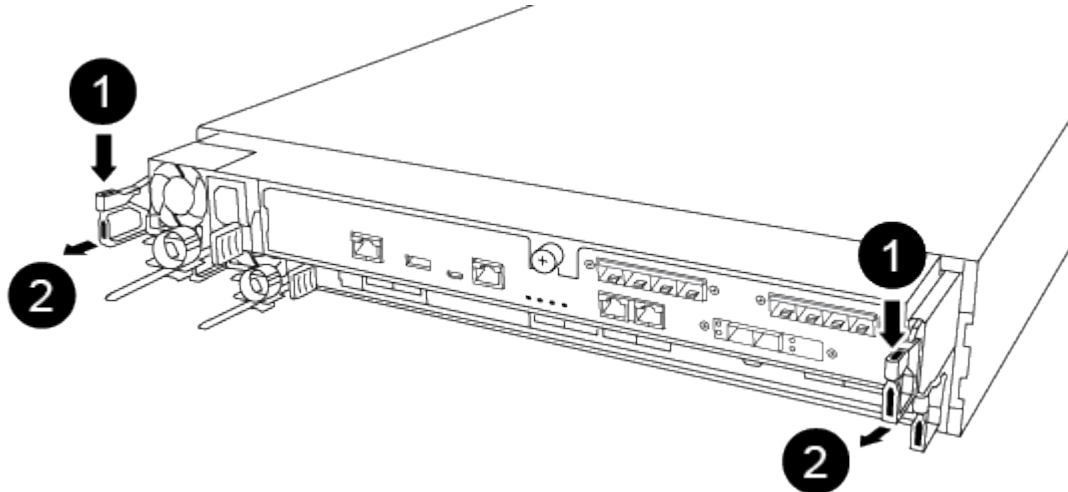

<b>1</b>	Lever
<b>2</b>	Latching mechanism

5. Using both hands, grasp the controller module sides and gently pull it out of the chassis and set it on a flat, stable surface.
6. Turn the thumbscrew on the front of the controller module anti-clockwise and open the controller module

cover.

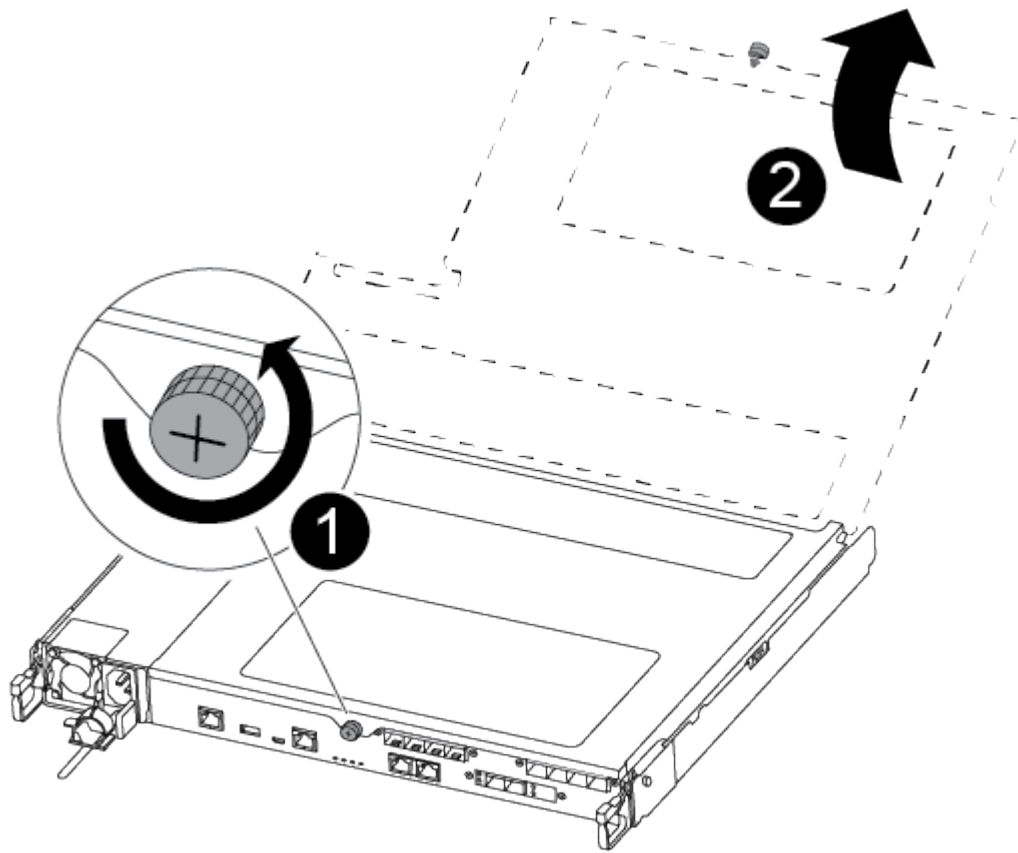

<b>1</b>	Thumbscrew
<b>2</b>	Controller module cover.

7. Lift out the air duct cover.

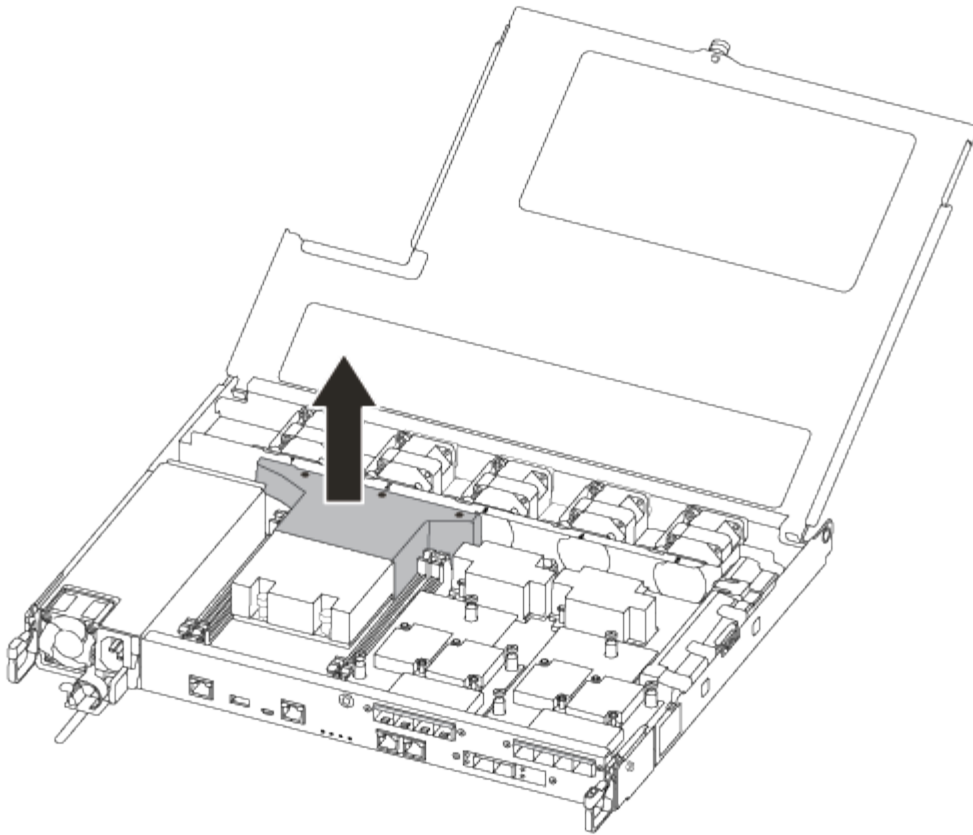

## Step 2: Move the power supply

You must move the power supply from the impaired controller module to the replacement controller module when you replace a controller module.

1. Disconnect the power supply.
2. Open the power cable retainer, and then unplug the power cable from the power supply.
3. Unplug the power cable from the power source.
4. Rotate the cam handle such that it can be used to pull power supply out of the controller module while pressing the locking tab.



Do not use excessive force when sliding the controller module into the chassis to avoid damaging the connectors.

The power supply is short. Always use two hands to support it when removing it from the controller module so that it does not suddenly swing free from the controller module and injure you.

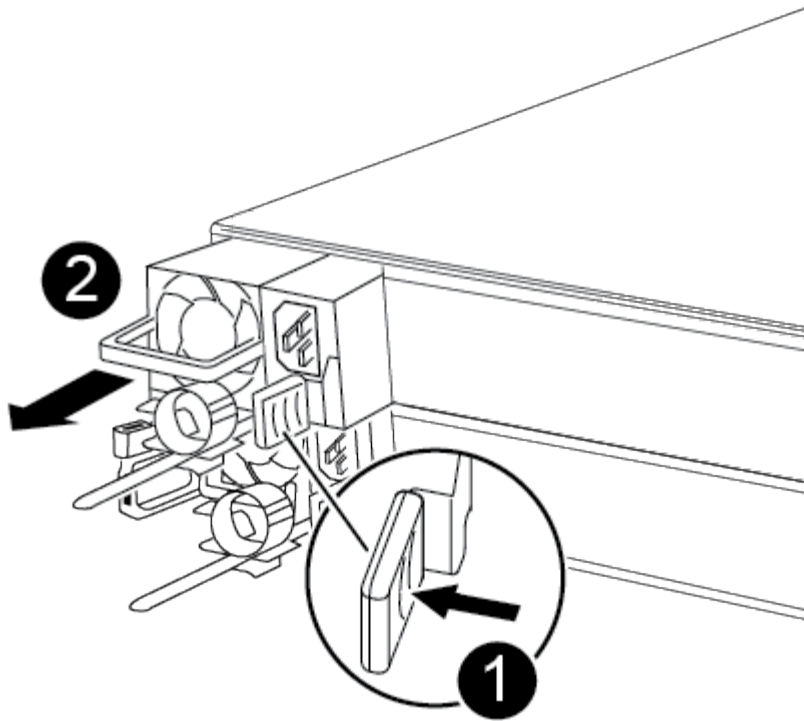

1	Blue power supply locking tab
2	Power supply

5. Move the power supply to the new controller module, and then install it.
6. Using both hands, support and align the edges of the power supply with the opening in the controller module, and then gently push the power supply into the controller module until the locking tab clicks into place.

The power supplies will only properly engage with the internal connector and lock in place one way.



To avoid damaging the internal connector, do not use excessive force when sliding the power supply into the system.

### Step 3: Move the fans

You must move the fans from the impaired controller module to the replacement module when replacing a failed controller module.

1. Remove the fan module by pinching the side of the fan module, and then lifting the fan module straight out of the controller module.

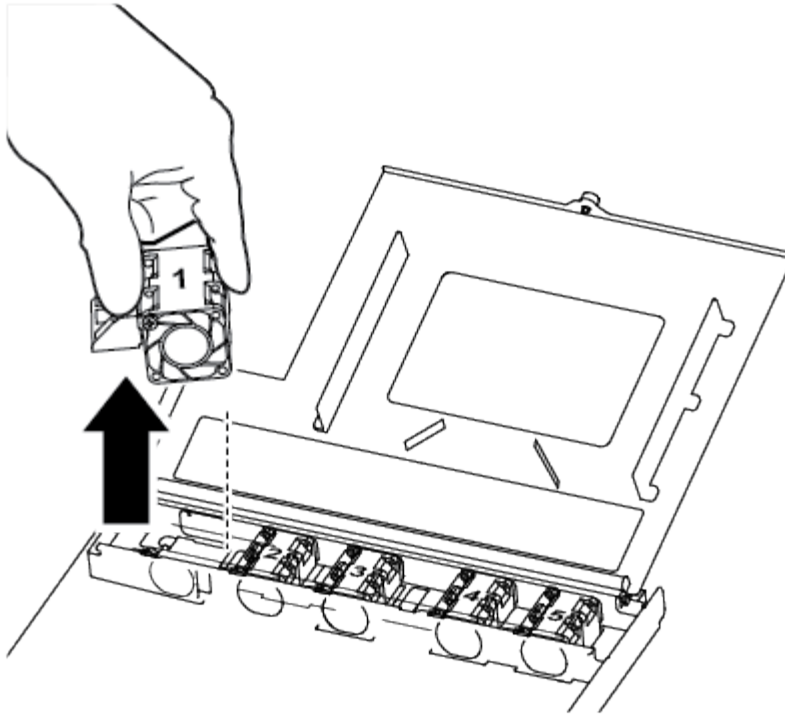

1

Fan module

2. Move the fan module to the replacement controller module, and align the edges of the fan module with the opening in the controller module, and then slide the fan module in.
3. Repeat these steps for the remaining fan modules.

#### Step 4: Move the boot media

You must move the boot media device from the impaired controller module to the replacement controller module.

You need a #1 magnetic Phillips head screwdriver to remove the screw that holds the boot media in place. Due to the space constraints within the controller module, you should also have a magnet to transfer the screw on to so that you do not lose it.

1. Locate and move the boot media from the impaired controller module to the replacement controller module.

The boot media is located under the air duct cover you removed earlier in this procedure.

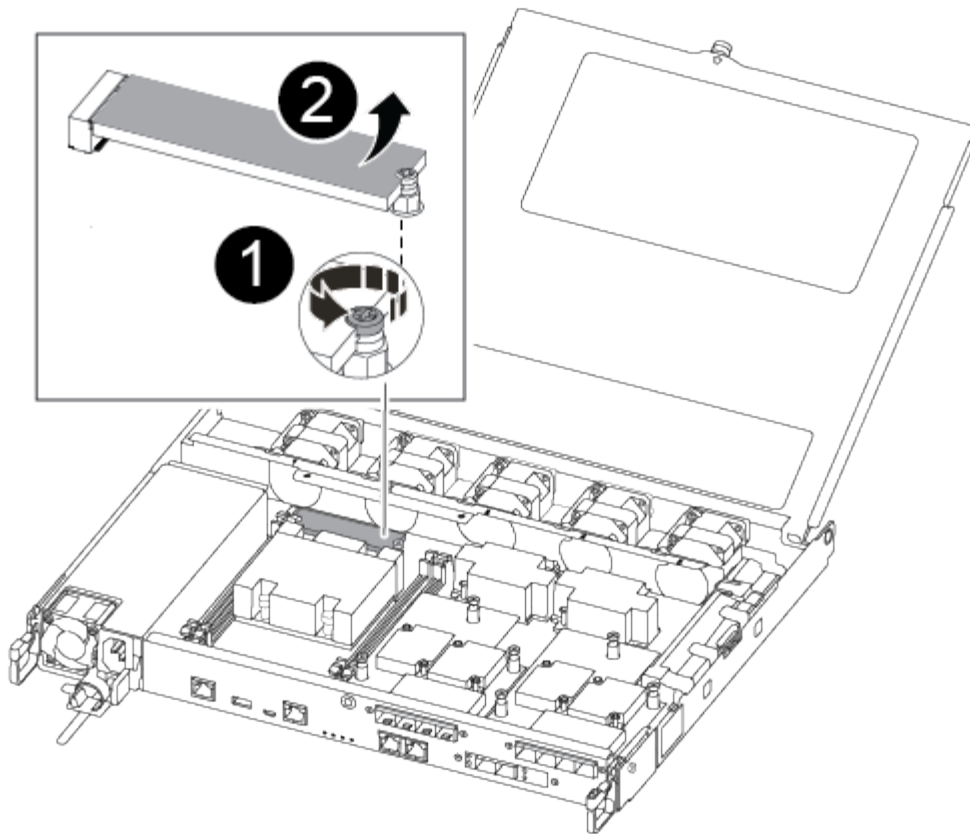

1	Remove the screw securing the boot media to the motherboard in the impaired controller module.
2	Lift the boot media out of the impaired controller module.

2. Using the #1 magnetic screwdriver, remove the screw from the boot media, and set it aside safely on the magnet.
3. Gently lift the boot media directly out of the socket and align it into place in the replacement controller module.
4. Using the #1 magnetic screwdriver, insert and tighten the screw on the boot media.



Do not apply force when tightening the screw on the boot media; you might crack it.

### Step 5: Move the DIMMs

To move the DIMMs, locate and move them from the impaired controller into the replacement controller and follow the specific sequence of steps.

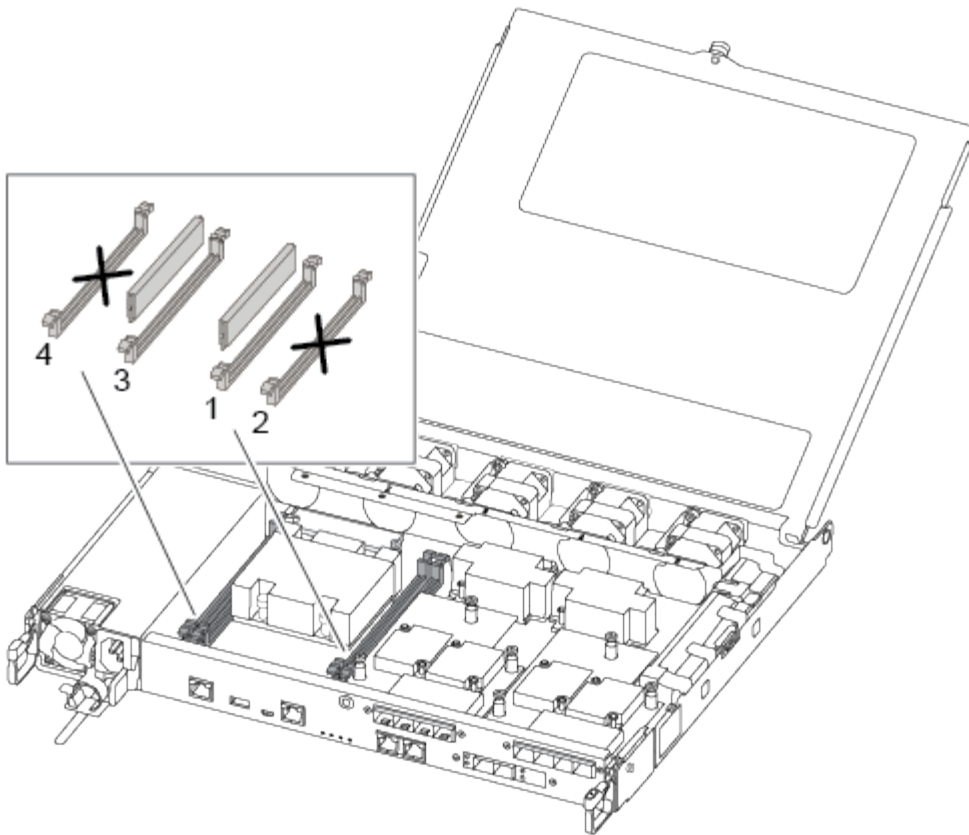

Install each DIMM into the same slot it occupied in the impaired controller module.

1. Slowly push apart the DIMM ejector tabs on either side of the DIMM, and slide the DIMM out of the slot.



Hold the DIMM by the edges to avoid pressure on the components on the DIMM circuit board.

2. Locate the corresponding DIMM slot on the replacement controller module.
3. Make sure that the DIMM ejector tabs on the DIMM socket are in the open position, and then insert the DIMM squarely into the socket.

The DIMMs fit tightly in the socket. If not, reinsert the DIMM to realign it with the socket.

4. Visually inspect the DIMM to verify that it is evenly aligned and fully inserted into the socket.
5. Repeat these steps for the remaining DIMM.

### Step 6: Move a mezzanine card

To move a mezzanine card, you must remove the cabling and any QSFPs and SFPs from the ports, move the mezzanine card to the replacement controller, reinstall any QSFPs and SFPs onto the ports, and cable the ports.

1. Locate and move the mezzanine cards from your impaired controller module.



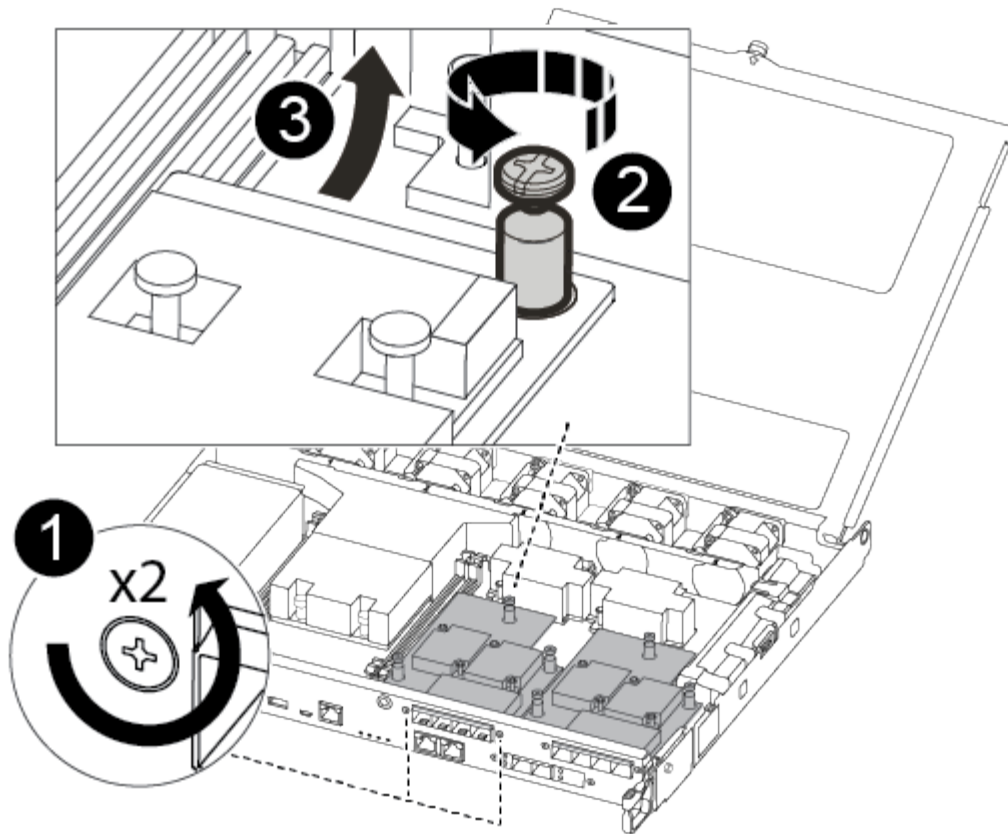

1	Remove screws on the face of the controller module.
2	Loosen the screw in the controller module.
3	Move the mezzanine card.

2. Unplug any cabling associated with the mezzanine card.

Make sure that you label the cables so that you know where they came from.

- a. Remove any SFP or QSFP modules that might be in the mezzanine card and set it aside.
- b. Using the #1 magnetic screwdriver, remove the screws from the face of the impaired controller module and from the mezzanine card, and set them aside safely on the magnet.
- c. Gently lift the mezzanine card out of the socket and move it to the same position in the replacement controller.
- d. Gently align the mezzanine card into place in the replacement controller.
- e. Using the #1 magnetic screwdriver, insert and tighten the screws on the face of the replacement controller module and on the mezzanine card.



Do not apply force when tightening the screw on the mezzanine card; you might crack it.

3. Repeat these steps if there is another mezzanine card in the impaired controller module.

4. Insert the SFP or QSFP modules that were removed onto the mezzanine card.

### Step 7: Move the NV battery

When replacing the controller module, you must move the NV battery from the impaired controller module to the replacement controller module.

1. Locate and move the NVMEM battery from your impaired controller module to the replacement controller module.

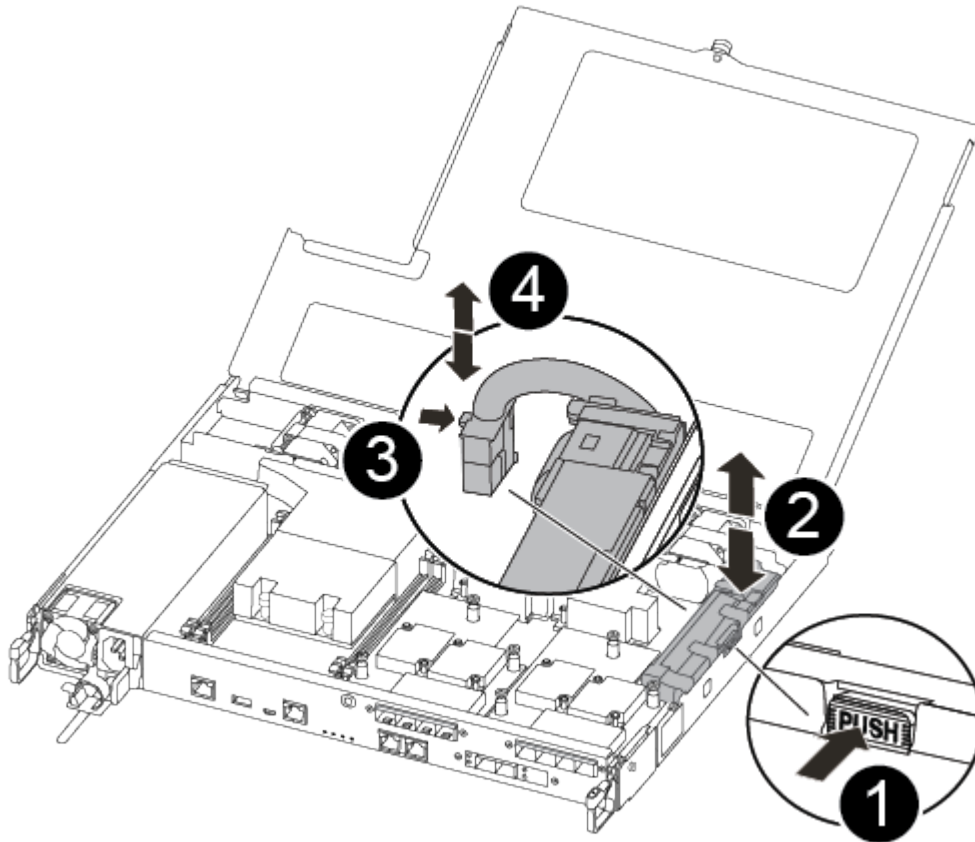

1	Squeeze the clip on the face of the battery plug.
2	Unplug the battery cable from the socket.
3	Grasp the battery and press the blue locking tab marked PUSH.
4	Lift the battery out of the holder and controller module.

2. Locate the battery plug and squeeze the clip on the face of the battery plug to release the plug from the socket.
3. Grasp the battery and press the blue locking tab marked PUSH, and then lift the battery out of the holder and controller module.

4. Locate the corresponding NV battery holder on the replacement controller module and align the NV battery to the battery holder.
5. Insert the NV battery plug into the socket.
6. Slide the battery pack down along the sheet metal side wall until the support tabs on the side wall hook into the slots on the battery pack, and the battery pack latch engages and clicks into the opening on the side wall.
7. Press firmly down on the battery pack to make sure that it is locked into place.

### Step 8: Install the controller module

After all of the components have been moved from the impaired controller module to the replacement controller module, you must install the replacement controller module into the chassis, and then boot it to Maintenance mode.

You can use the following illustrations or the written steps to install the replacement controller module in the chassis.

1. If you have not already done so, install the air duct.

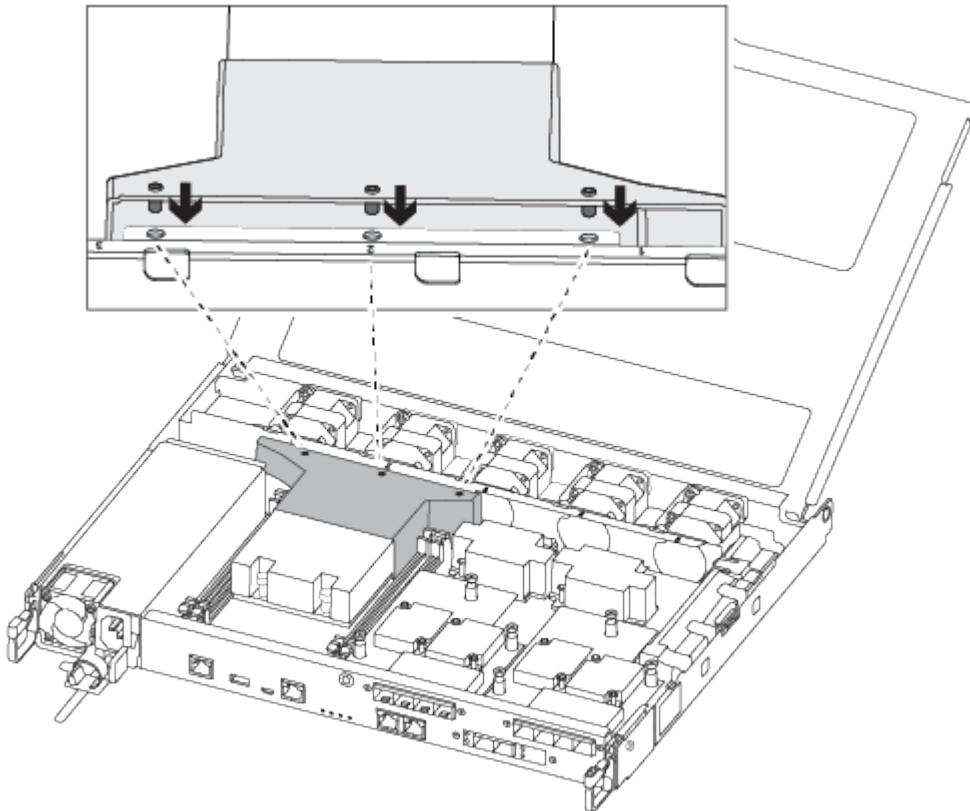

2. Close the controller module cover and tighten the thumbscrew.

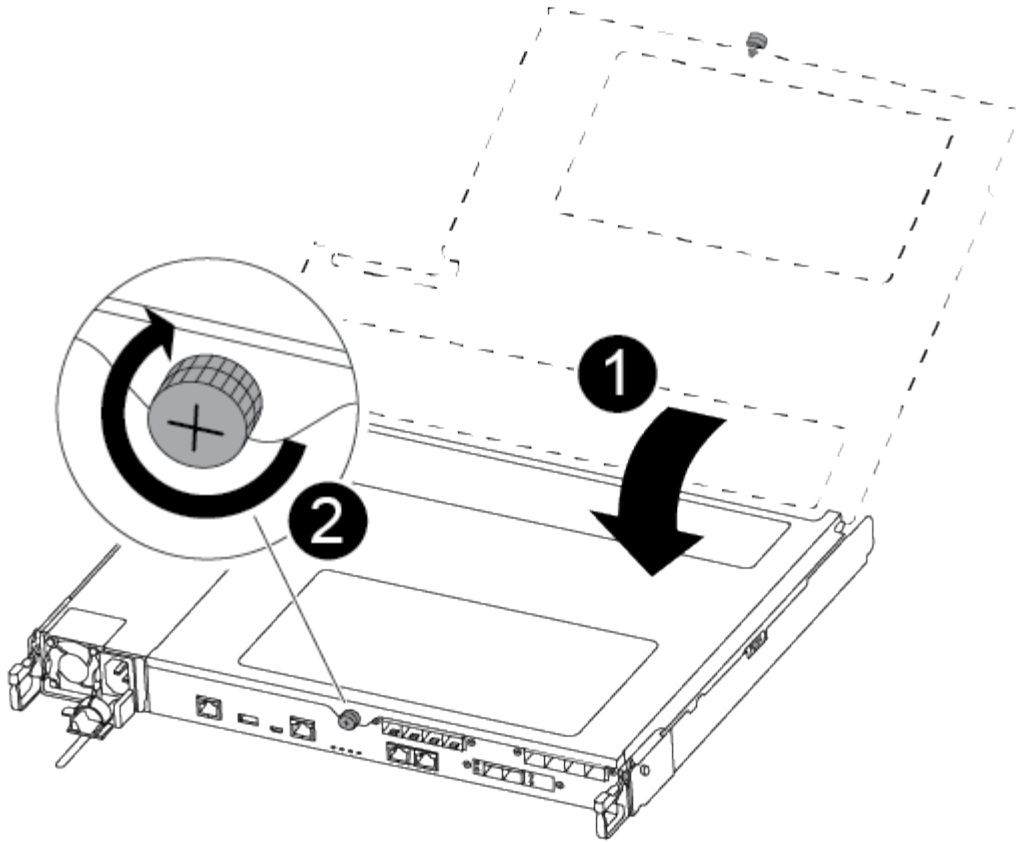

1	Controller module cover
2	Thumbscrew

3. Align the end of the controller module with the opening in the chassis, and then gently push the controller module halfway into the system.

 Do not completely insert the controller module in the chassis until instructed to do so.

4. Cable the management and console ports only, so that you can access the system to perform the tasks in the following sections.

 You will connect the rest of the cables to the controller module later in this procedure.

5. Insert the controller module into the chassis:

6. Ensure the latching mechanism arms are locked in the fully extended position.

7. Using both hands, align and gently slide the controller module into the latching mechanism arms until it stops.

8. Place your index fingers through the finger holes from the inside of the latching mechanism.

9. Press your thumbs down on the orange tabs on top of the latching mechanism and gently push the controller module over the stop.

10. Release your thumbs from the top of the latching mechanisms and continue pushing until the latching

mechanisms snap into place.

The controller module begins to boot as soon as it is fully seated in the chassis. Be prepared to interrupt the boot process.

The controller module should be fully inserted and flush with the edges of the chassis.

## Restore and verify the system configuration - ASA A250

After completing the hardware replacement and booting to Maintenance mode, you verify the low-level system configuration of the replacement controller and reconfigure system settings as necessary.

### Step 1: Set and verify system time after replacing the controller

You should check the time and date on the replacement controller module against the healthy controller module in an HA pair, or against a reliable time server in a stand-alone configuration. If the time and date do not match, you must reset them on the replacement controller module to prevent possible outages on clients due to time differences.

#### About this task

It is important that you apply the commands in the steps on the correct systems:

- The *replacement* node is the new node that replaced the impaired node as part of this procedure.
- The *healthy* node is the HA partner of the *replacement* node.

#### Steps

1. If the *replacement* node is not at the LOADER prompt, halt the system to the LOADER prompt.
2. On the *healthy* node, check the system time: `cluster date show`

The date and time are based on the configured timezone.

3. At the LOADER prompt, check the date and time on the *replacement* node: `show date`

The date and time are given in GMT.

4. If necessary, set the date in GMT on the replacement node: `set date mm/dd/yyyy`
5. If necessary, set the time in GMT on the replacement node: `set time hh:mm:ss`
6. At the LOADER prompt, confirm the date and time on the *replacement* node: `show date`

The date and time are given in GMT.

### Step 2: Verify and set the HA state of the controller

You must verify the HA state of the controller module and, if necessary, update the state to match your system configuration.

1. In Maintenance mode from the new controller module, verify that all components display the same HA state: `ha-config show`

The HA state should be the same for all components.

2. If the displayed system state of the controller module does not match your system configuration, set the HA state for the controller module: `ha-config modify controller ha-state`

The value for HA-state can be one of the following:

- ha
- mcc
- mccip
- non-ha

3. If the displayed system state of the controller module does not match your system configuration, set the HA state for the controller module: `ha-config modify controller ha-state`
4. Confirm that the setting has changed: `ha-config show`

## Recable the system and reassign disks - ASA A250

Continue the replacement procedure by recabling the storage and confirming disk reassignment.

### Step 1: Recable the system

Recable the controller module's storage and network connections.

#### Steps

1. Recable the the controller module to storage and network connections.
2. Verify that the cabling is correct by using [Active IQ Config Advisor](#).
  - a. Download and install Config Advisor.
  - b. Enter the information for the target system, and then click Collect Data.
  - c. Click the Cabling tab, and then examine the output. Make sure that all disk shelves are displayed and all disks appear in the output, correcting any cabling issues you find.
  - d. Check other cabling by clicking the appropriate tab, and then examining the output from Config Advisor.

### Step 2: Reassign disks

If the storage system is in an HA pair, the system ID of the new controller module is automatically assigned to the disks when the giveback occurs at the end of the procedure. You must confirm the system ID change when you boot the *replacement* controller and then verify that the change was implemented.

This procedure applies only to systems running ONTAP in an HA pair.

1. If the *replacement* controller is in Maintenance mode (showing the `*>` prompt, exit Maintenance mode and go to the LOADER prompt: `halt`
2. From the LOADER prompt on the *replacement* controller, boot the controller, entering `y` if you are prompted to override the system ID due to a system ID mismatch:
3. Wait until the `Waiting for giveback...` message is displayed on the *replacement* controller console and then, from the healthy controller, verify that the new partner system ID has been automatically assigned: `storage failover show`

In the command output, you should see a message that the system ID has changed on the impaired controller, showing the correct old and new IDs. In the following example, node2 has undergone replacement and has a new system ID of 151759706.

```
node1> `storage failover show`

Node                Partner                Takeover
-----                -----                -
node1                node2                false
partner (Old:
151759706), In takeover
node2                node1                -
(HA mailboxes)                Waiting for giveback

State Description
-----
System ID changed on
151759755, New:
151759706)
```

4. From the healthy controller, verify that any coredumps are saved:

a. Change to the advanced privilege level: `set -privilege advanced`

You can respond `y` when prompted to continue into advanced mode. The advanced mode prompt appears (`*>`).

b. Save any coredumps: `system node run -node local-node-name partner savecore`

c. Wait for the `savecore` command to complete before issuing the giveback.

You can enter the following command to monitor the progress of the `savecore` command: `system node run -node local-node-name partner savecore -s`

d. Return to the admin privilege level: `set -privilege admin`

5. If your storage system has Storage or Volume Encryption configured, you must restore Storage or Volume Encryption functionality by using one of the following procedures, depending on whether you are using onboard or external key management:

- [Restore onboard key management encryption keys](#)
- [Restore external key management encryption keys](#)

6. Give back the controller:

a. From the healthy controller, give back the replaced controller's storage: `storage failover giveback -ofnode replacement_node_name`

The *replacement* controller takes back its storage and completes booting.

If you are prompted to override the system ID due to a system ID mismatch, you should enter `y`.



If the giveback is vetoed, you can consider overriding the vetoes.

[Find the High-Availability Configuration content for your version of ONTAP 9](#)

- b. After the giveback has been completed, confirm that the HA pair is healthy and that takeover is possible: `storage failover show`

The output from the `storage failover show` command should not include the System ID changed on partner message.

7. Verify that the disks were assigned correctly: `storage disk show -ownership`

The disks belonging to the *replacement* controller should show the new system ID. In the following example, the disks owned by node1 now show the new system ID, 1873775277:

```
node1> `storage disk show -ownership`

Disk  Aggregate Home  Owner  DR Home  Home ID      Owner ID      DR Home ID
Reserver Pool
-----
-----
-----
1.0.0  aggr0_1  node1 node1  -        1873775277  1873775277  -
1873775277 Pool10
1.0.1  aggr0_1  node1 node1  -        1873775277  1873775277  -
1873775277 Pool10
.
.
.
```

8. If the system is in a MetroCluster configuration, monitor the status of the controller: `metrocluster node show`

The MetroCluster configuration takes a few minutes after the replacement to return to a normal state, at which time each controller will show a configured state, with DR Mirroring enabled and a mode of normal. The `metrocluster node show -fields node-systemid` command output displays the old system ID until the MetroCluster configuration returns to a normal state.

9. If the controller is in a MetroCluster configuration, depending on the MetroCluster state, verify that the DR home ID field shows the original owner of the disk if the original owner is a controller on the disaster site.

This is required if both of the following are true:

- The MetroCluster configuration is in a switchover state.
- The *replacement* controller is the current owner of the disks on the disaster site.

[Disk ownership changes during HA takeover and MetroCluster switchover in a four-node MetroCluster configuration](#)

10. If your system is in a MetroCluster configuration, verify that each controller is configured: `metrocluster node show - fields configuration-state`



```

node1_siteA::> metrocluster node show -fields configuration-state

dr-group-id          cluster node          configuration-state
-----
-----
1 node1_siteA        node1mcc-001         configured
1 node1_siteA        node1mcc-002         configured
1 node1_siteB        node1mcc-003         configured
1 node1_siteB        node1mcc-004         configured

4 entries were displayed.

```

11. Verify that the expected volumes are present for each controller: `vol show -node node-name`
12. If you disabled automatic takeover on reboot, enable it from the healthy controller: `storage failover modify -node replacement-node-name -onreboot true`

### Complete system restoration - ASA A250

To restore your system to full operation, you must restore the NetApp Storage Encryption configuration (if necessary), and install licenses for the new controller, and return the failed part to NetApp, as described in the RMA instructions shipped with the kit.

#### Step 1: Install licenses for the replacement controller in ONTAP

You must install new licenses for the *replacement* node if the impaired node was using ONTAP features that require a standard (node-locked) license. For features with standard licenses, each node in the cluster should have its own key for the feature.

#### About this task

Until you install license keys, features requiring standard licenses continue to be available to the *replacement* node. However, if the impaired node was the only node in the cluster with a license for the feature, no configuration changes to the feature are allowed. Also, using unlicensed features on the node might put you out of compliance with your license agreement, so you should install the replacement license key or keys on the *replacement* node as soon as possible.

#### Before you begin

The licenses keys must be in the 28-character format.

You have a 90-day grace period in which to install the license keys. After the grace period, all old licenses are invalidated. After a valid license key is installed, you have 24 hours to install all of the keys before the grace period ends.

#### Steps

1. If you need new license keys, obtain replacement license keys on the [NetApp Support Site](#) in the My Support section under Software licenses.



The new license keys that you require are automatically generated and sent to the email address on file. If you fail to receive the email with the license keys within 30 days, you should contact technical support.

2. Install each license key: `system license add -license-code license-key, license-key...`
3. Remove the old licenses, if desired:
  - a. Check for unused licenses: `license clean-up -unused -simulate`
  - b. If the list looks correct, remove the unused licenses: `license clean-up -unused`

## Step 2: Verify LIFs and registering the serial number

Before returning the *replacement* node to service, you should verify that the LIFs are on their home ports, and register the serial number of the *replacement* node if AutoSupport is enabled, and reset automatic giveback.

### Steps

1. Verify that the logical interfaces are reporting to their home server and ports: `network interface show -is-home false`  
  
If any LIFs are listed as false, revert them to their home ports: `network interface revert -vserver * -lif *`
2. Register the system serial number with NetApp Support.
  - If AutoSupport is enabled, send an AutoSupport message to register the serial number.
  - If AutoSupport is not enabled, call [NetApp Support](#) to register the serial number.
3. If an AutoSupport maintenance window was triggered, end it by using the `system node autosupport invoke -node * -type all -message MAINT=END` command.
4. If automatic giveback was disabled, reenabling it: `storage failover modify -node local -auto-giveback true`

## Step 3: Return the failed part to NetApp

Return the failed part to NetApp, as described in the RMA instructions shipped with the kit. See the [Part Return and Replacements](#) page for further information.

### Replace a DIMM - ASA A250

You must replace a DIMM in the controller module when your system registers an increasing number of correctable error correction codes (ECC); failure to do so causes a system panic.

#### About this task

All other components in the system must be functioning properly; if not, you must contact technical support.

You must replace the failed component with a replacement FRU component you received from your provider.

## Step 1: Shut down the impaired controller

To shut down the impaired controller, you must determine the status of the controller and, if necessary, take

over the controller so that the healthy controller continues to serve data from the impaired controller storage.

### About this task

- If you have a SAN system, you must have checked event messages (`cluster kernel-service show`) for the impaired controller SCSI blade. The `cluster kernel-service show` command (from `priv advanced mode`) displays the node name, quorum status of that node, availability status of that node, and operational status of that node.

Each SCSI-blade process should be in quorum with the other nodes in the cluster. Any issues must be resolved before you proceed with the replacement.

- If you have a cluster with more than two nodes, it must be in quorum. If the cluster is not in quorum or a healthy controller shows false for eligibility and health, you must correct the issue before shutting down the impaired controller; see [Synchronize a node with the cluster](#).

### Steps

1. If AutoSupport is enabled, suppress automatic case creation by invoking an AutoSupport message:  
`system node autosupport invoke -node * -type all -message MAINT=<# of hours>h`

The following AutoSupport message suppresses automatic case creation for two hours: `cluster1:>`  
`system node autosupport invoke -node * -type all -message MAINT=2h`

2. Disable automatic giveback from the console of the healthy controller: `storage failover modify -node local -auto-giveback false`



When you see *Do you want to disable auto-giveback?*, enter *y*.

3. Take the impaired controller to the LOADER prompt:

If the impaired controller is displaying...	Then...
The LOADER prompt	Go to the next step.
Waiting for giveback...	Press Ctrl-C, and then respond <i>y</i> when prompted.
System prompt or password prompt	Take over or halt the impaired controller from the healthy controller: <code>storage failover takeover -ofnode impaired_node_name</code>  When the impaired controller shows Waiting for giveback..., press Ctrl-C, and then respond <i>y</i> .

### Step 2: Remove the controller module

You must remove the controller module from the chassis when you replace a component inside the controller module.

Make sure that you label the cables so that you know where they came from.

1. If you are not already grounded, properly ground yourself.

2. Unplug the controller module power supplies from the source.
3. Release the power cable retainers, and then unplug the cables from the power supplies.
4. Insert your forefinger into the latching mechanism on either side of the controller module, press the lever with your thumb, and gently pull the controller a few inches out of the chassis.



If you have difficulty removing the controller module, place your index fingers through the finger holes from the inside (by crossing your arms).

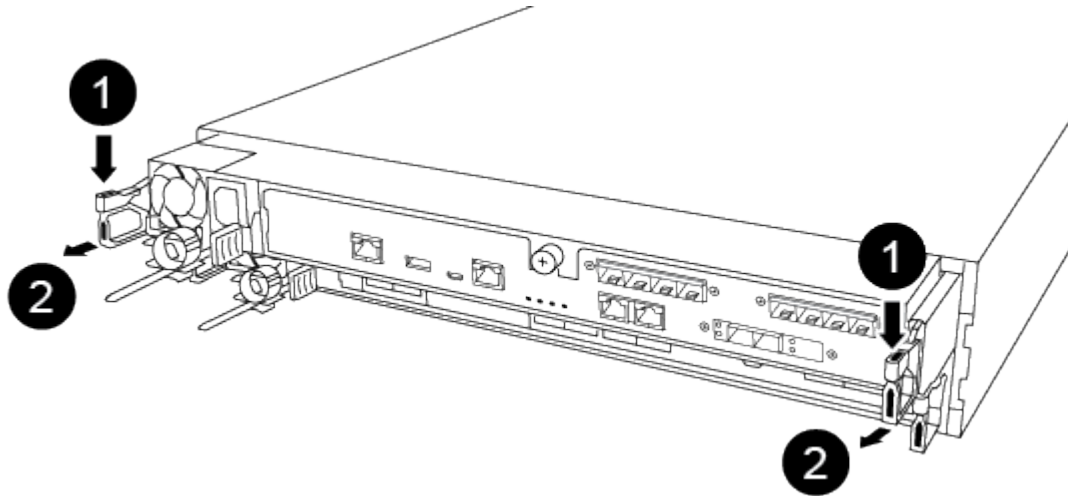

<b>1</b>	Lever
<b>2</b>	Latching mechanism

5. Using both hands, grasp the controller module sides and gently pull it out of the chassis and set it on a flat, stable surface.
6. Turn the thumbscrew on the front of the controller module anti-clockwise and open the controller module cover.

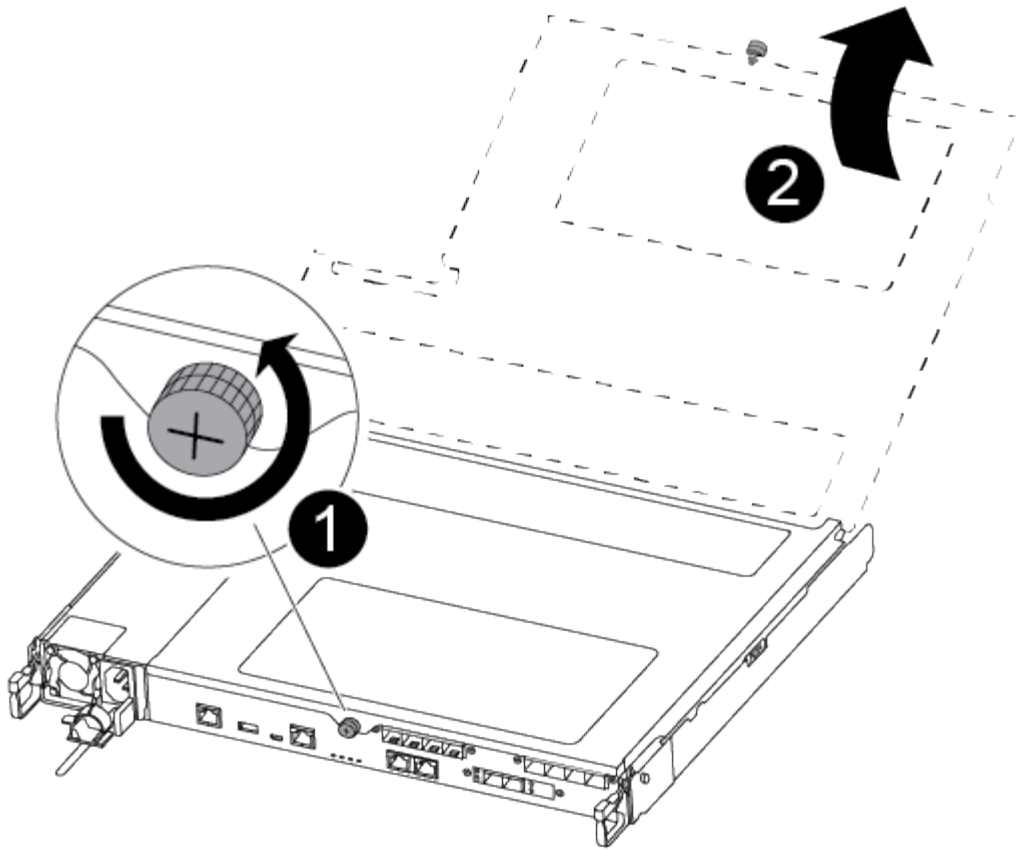

1	Thumbscrew
2	Controller module cover.

7. Lift out the air duct cover.

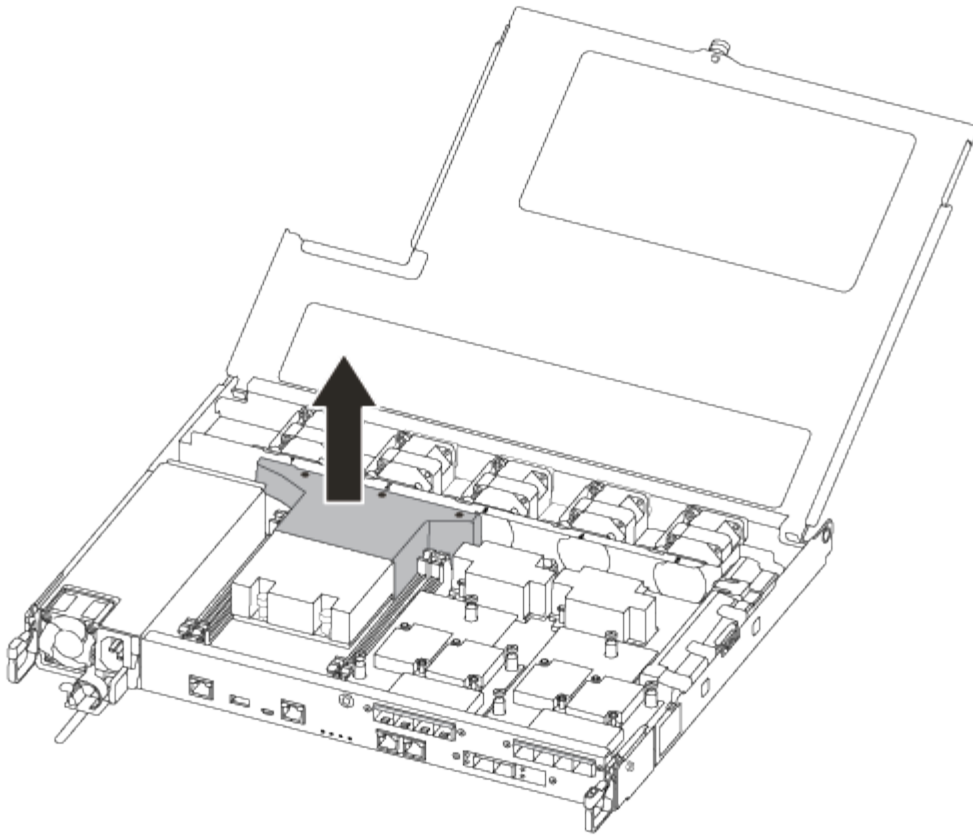

### Step 3: Replace a DIMM

To replace a DIMM, you must locate it in the controller module using the DIMM map label on top of the air duct and then replace it following the specific sequence of steps.

Use the following video or the tabulated steps to replace a DIMM:

[Animation - Replace a DIMM](#)

1. Replace the impaired DIMM on your controller module.

The DIMMs are in slot 3 or 1 on the motherboard. Slot 2 and 4 are left empty. Do not attempt to install DIMMs into these slots.

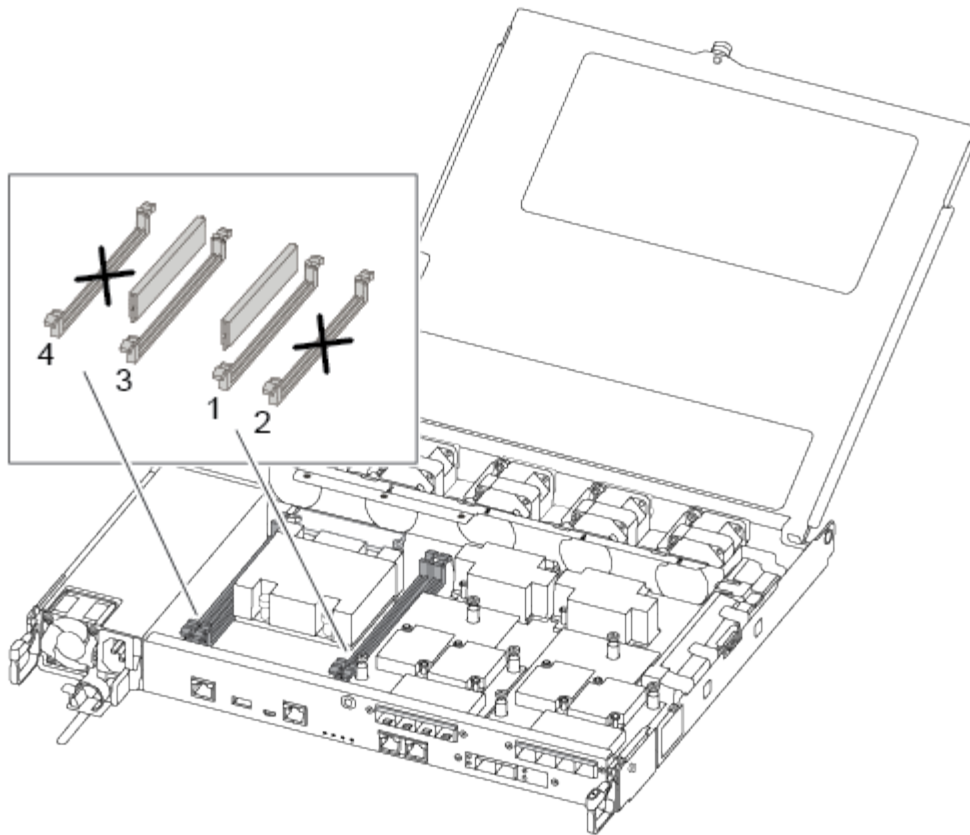

2. Note the orientation of the DIMM in the socket so that you can insert the replacement DIMM in the proper orientation.
3. Slowly push apart the DIMM ejector tabs on either side of the DIMM, and slide the DIMM out of the slot.
4. Leave DIMM ejector tabs on the connector in the open position.
5. Remove the replacement DIMM from the antistatic shipping bag, hold the DIMM by the corners, and align it to the slot.



Hold the DIMM by the edges to avoid pressure on the components on the DIMM circuit board.

6. Insert the replacement DIMM squarely into the slot.

The DIMMs fit tightly in the socket. If not, reinsert the DIMM to realign it with the socket.

7. Visually inspect the DIMM to verify that it is evenly aligned and fully inserted into the socket.

#### Step 4: Install the controller module

After you have replaced the component in the controller module, you must reinstall the controller module into the chassis, and then boot it.

You can use the following illustrations or the written steps to install the replacement controller module in the chassis.

1. If you have not already done so, install the air duct.

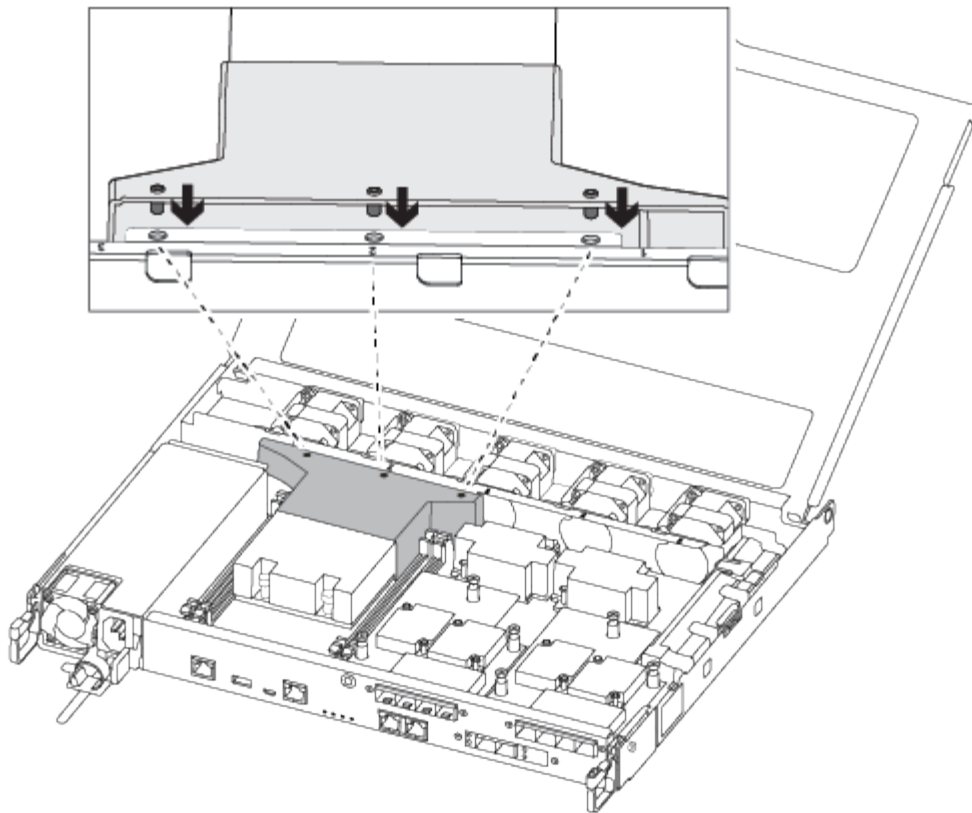

2. Close the controller module cover and tighten the thumbscrew.

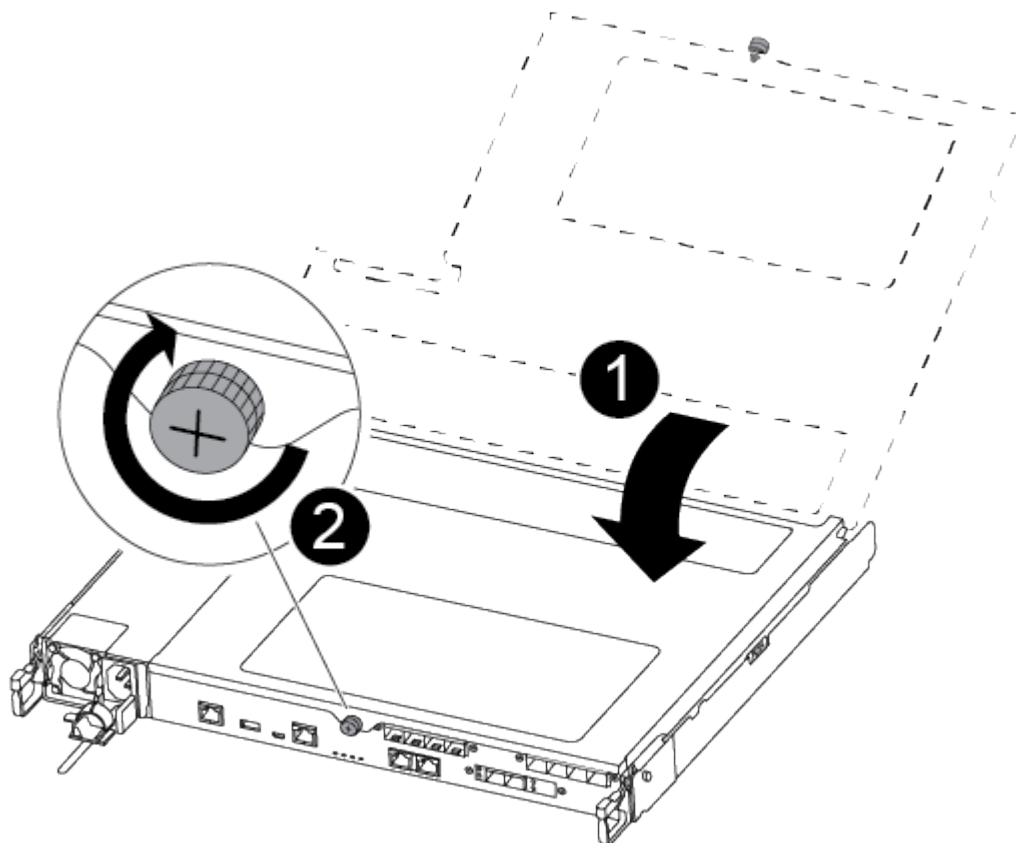



<b>1</b>	Controller module cover
<b>2</b>	Thumbscrew

3. Insert the controller module into the chassis:

- a. Ensure the latching mechanism arms are locked in the fully extended position.
- b. Using both hands, align and gently slide the controller module into the latching mechanism arms until it stops.
- c. Place your index fingers through the finger holes from the inside of the latching mechanism.
- d. Press your thumbs down on the orange tabs on top of the latching mechanism and gently push the controller module over the stop.
- e. Release your thumbs from the top of the latching mechanisms and continue pushing until the latching mechanisms snap into place.

The controller module begins to boot as soon as it is fully seated in the chassis.

The controller module should be fully inserted and flush with the edges of the chassis.

4. Cable the management and console ports only, so that you can access the system to perform the tasks in the following sections.



You will connect the rest of the cables to the controller module later in this procedure.

### Step 5: Return the failed part to NetApp

Return the failed part to NetApp, as described in the RMA instructions shipped with the kit. See the [Part Return and Replacements](#) page for further information.

#### Replace SSD Drive or HDD Drive - ASA A250

You can replace a failed drive nondisruptively while I/O is in progress. The procedure for replacing an SSD is meant for non-spinning drives and the procedure for replacing an HDD is meant for spinning drives.

When a drive fails, the platform logs a warning message to the system console indicating which drive has failed. In addition, both the fault LED on the operator display panel and the fault LED on the failed drive are illuminated.

#### Before you begin

- Follow best practice and install the current version of the Disk Qualification Package (DQP) before replacing a drive.
- Identify the failed drive by running the `storage disk show -broken` command from the system console.

The failed drive appears in the list of failed drives. If it does not, you should wait, and then run the command again.



Depending on the type and capacity, it can take up to several hours for the drive to appear in the list of failed drives.

- Determine whether SED authentication is enabled.

How you replace the drive depends on how the drive is being used. If SED authentication is enabled, you must use the SED replacement instructions in the [ONTAP 9 NetApp Encryption Power Guide](#). These Instructions describe additional steps you must perform before and after replacing an SED.

- Make sure the replacement drive is supported by your platform. See the [NetApp Hardware Universe](#).
- Make sure all other components in the system are functioning properly; if not, you must contact technical support.

#### **About this task**

- Drive firmware is automatically updated (nondisruptively) on new drives that have non current firmware versions.
- When replacing a drive, you must wait one minute between the removal of the failed drive and the insertion of the replacement drive to allow the storage system to recognize the existence of the new drive.

## Option 1: Replace SSD

### Steps

1. If you want to manually assign drive ownership for the replacement drive, you need to disable automatic drive assignment replacement drive, if it is enabled



You manually assign drive ownership and then reenables automatic drive assignment later in this procedure.

- a. Verify whether automatic drive assignment is enabled: `storage disk option show`

You can enter the command on either controller module.

If automatic drive assignment is enabled, the output shows `on` in the “Auto Assign” column (for each controller module).

- b. If automatic drive assignment is enabled, disable it: `storage disk option modify -node node_name -autoassign off`

You must disable automatic drive assignment on both controller modules.

2. Properly ground yourself.
3. Physically identify the failed drive.

When a drive fails, the system logs a warning message to the system console indicating which drive failed. Additionally, the attention (amber) LED on the drive shelf operator display panel and the failed drive illuminate.



The activity (green) LED on a failed drive can be illuminated (solid), which indicates that the drive has power, but should not be blinking, which indicates I/O activity. A failed drive has no I/O activity.

4. Remove the failed drive:
  - a. Press the release button on the drive face to open the cam handle.
  - b. Slide the drive out of the shelf using the cam handle and supporting the drive with your other hand.

5. Wait a minimum of 70 seconds before inserting the replacement drive.

This allows the system to recognize that a drive was removed.

6. Insert the replacement drive:
  - a. With the cam handle in the open position, use both hands to insert the replacement drive.
  - b. Push until the drive stops.
  - c. Close the cam handle so that the drive is fully seated into the midplane and the handle clicks into place.

Be sure to close the cam handle slowly so that it aligns correctly with the face of the drive.

7. Verify that the drive's activity (green) LED is illuminated.

When the drive's activity LED is solid, it means that the drive has power. When the drive's activity LED is blinking, it means that the drive has power and I/O is in progress. If the drive firmware is automatically updating, the LED blinks.

8. If you are replacing another drive, repeat Steps 3 through 7.
9. If you disabled automatic drive assignment in Step 1, then, manually assign drive ownership and then reenables automatic drive assignment if needed.

- a. Display all unowned drives: `storage disk show -container-type unassigned`

You can enter the command on either controller module.

- b. Assign each drive: `storage disk assign -disk disk_name -owner node_name`

You can enter the command on either controller module.

You can use the wildcard character to assign more than one drive at once.

- c. Reenable automatic drive assignment if needed: `storage disk option modify -node node_name -autoassign on`

You must reenables automatic drive assignment on both controller modules.

10. Return the failed part to NetApp, as described in the RMA instructions shipped with the kit.

Contact technical support at [NetApp Support](#), 888-463-8277 (North America), 00-800-44-638277 (Europe), or +800-800-80-800 (Asia/Pacific) if you need the RMA number or additional help with the replacement procedure.

## Option 2: Replace HDD

1. If you want to manually assign drive ownership for the replacement drive, you need to disable automatic drive assignment replacement drive, if it is enabled



You manually assign drive ownership and then reenables automatic drive assignment later in this procedure.

- a. Verify whether automatic drive assignment is enabled: `storage disk option show`

You can enter the command on either controller module.

If automatic drive assignment is enabled, the output shows `on` in the "Auto Assign" column (for each controller module).

- b. If automatic drive assignment is enabled, disable it: `storage disk option modify -node node_name -autoassign off`

You must disable automatic drive assignment on both controller modules.

2. Properly ground yourself.
3. Gently remove the bezel from the front of the platform.
4. Identify the failed disk drive from the system console warning message and the illuminated fault LED on the disk drive

5. Press the release button on the disk drive face.

Depending on the storage system, the disk drives have the release button located at the top or on the left of the disk drive face.

For example, the following illustration shows a disk drive with the release button located on the top of the disk drive face:

The cam handle on the disk drive springs open partially and the disk drive releases from the midplane.

6. Pull the cam handle to its fully open position to unseat the disk drive from the midplane.

7. Slide out the disk drive slightly and allow the disk to safely spin down, which can take less than one minute, and then, using both hands, remove the disk drive from the disk shelf.

8. With the cam handle in the open position, insert the replacement disk drive into the drive bay, firmly pushing until the disk drive stops.



Wait a minimum of 10 seconds before inserting a new disk drive. This allows the system to recognize that a disk drive was removed.



If your platform drive bays are not fully loaded with drives, it is important to place the replacement drive into the same drive bay from which you removed the failed drive.



Use two hands when inserting the disk drive, but do not place hands on the disk drive boards that are exposed on the underside of the disk carrier.

9. Close the cam handle so that the disk drive is fully seated into the midplane and the handle clicks into place.

Be sure to close the cam handle slowly so that it aligns correctly with the face of the disk drive..

10. If you are replacing another disk drive, repeat Steps 4 through 9.

11. Reinstall the bezel.

12. If you disabled automatic drive assignment in Step 1, then, manually assign drive ownership and then reenables automatic drive assignment if needed.

a. Display all unowned drives: `storage disk show -container-type unassigned`

You can enter the command on either controller module.

b. Assign each drive: `storage disk assign -disk disk_name -owner owner_name`

You can enter the command on either controller module.

You can use the wildcard character to assign more than one drive at once.

c. Reenable automatic drive assignment if needed: `storage disk option modify -node node_name -autoassign on`

You must reenable automatic drive assignment on both controller modules.

13. Return the failed part to NetApp, as described in the RMA instructions shipped with the kit.

Contact technical support at [NetApp Support](#), 888-463-8277 (North America), 00-800-44-638277 (Europe), or +800-800-80-800 (Asia/Pacific) if you need the RMA number or additional help with the replacement procedure.

## Replace a fan - ASA A250

To replace a fan, remove the failed fan module and replace it with a new fan module.

### Step 1: Shut down the impaired controller

To shut down the impaired controller, you must determine the status of the controller and, if necessary, take over the controller so that the healthy controller continues to serve data from the impaired controller storage.

#### About this task

- If you have a SAN system, you must have checked event messages (`cluster kernel-service show`) for the impaired controller SCSI blade. The `cluster kernel-service show` command (from `priv advanced` mode) displays the node name, quorum status of that node, availability status of that node, and operational status of that node.

Each SCSI-blade process should be in quorum with the other nodes in the cluster. Any issues must be resolved before you proceed with the replacement.

- If you have a cluster with more than two nodes, it must be in quorum. If the cluster is not in quorum or a healthy controller shows `false` for eligibility and health, you must correct the issue before shutting down the impaired controller; see [Synchronize a node with the cluster](#).

#### Steps

1. If AutoSupport is enabled, suppress automatic case creation by invoking an AutoSupport message:  

```
system node autosupport invoke -node * -type all -message MAINT=<# of hours>h
```

The following AutoSupport message suppresses automatic case creation for two hours: `cluster1:>`  

```
system node autosupport invoke -node * -type all -message MAINT=2h
```

2. Disable automatic giveback from the console of the healthy controller: 

```
storage failover modify -node local -auto-giveback false
```



When you see *Do you want to disable auto-giveback?*, enter `y`.

3. Take the impaired controller to the LOADER prompt:

If the impaired controller is displaying...	Then...
The LOADER prompt	Go to the next step.
Waiting for giveback...	Press Ctrl-C, and then respond <code>y</code> when prompted.

If the impaired controller is displaying...	Then...
System prompt or password prompt	Take over or halt the impaired controller from the healthy controller: <pre>storage failover takeover -ofnode impaired_node_name</pre> When the impaired controller shows Waiting for giveback..., press Ctrl-C, and then respond <i>y</i> .

## Step 2: Remove the controller module

You must remove the controller module from the chassis when you replace a component inside the controller module.

Make sure that you label the cables so that you know where they came from.

1. If you are not already grounded, properly ground yourself.
2. Unplug the controller module power supplies from the source.
3. Release the power cable retainers, and then unplug the cables from the power supplies.
4. Insert your forefinger into the latching mechanism on either side of the controller module, press the lever with your thumb, and gently pull the controller a few inches out of the chassis.



If you have difficulty removing the controller module, place your index fingers through the finger holes from the inside (by crossing your arms).

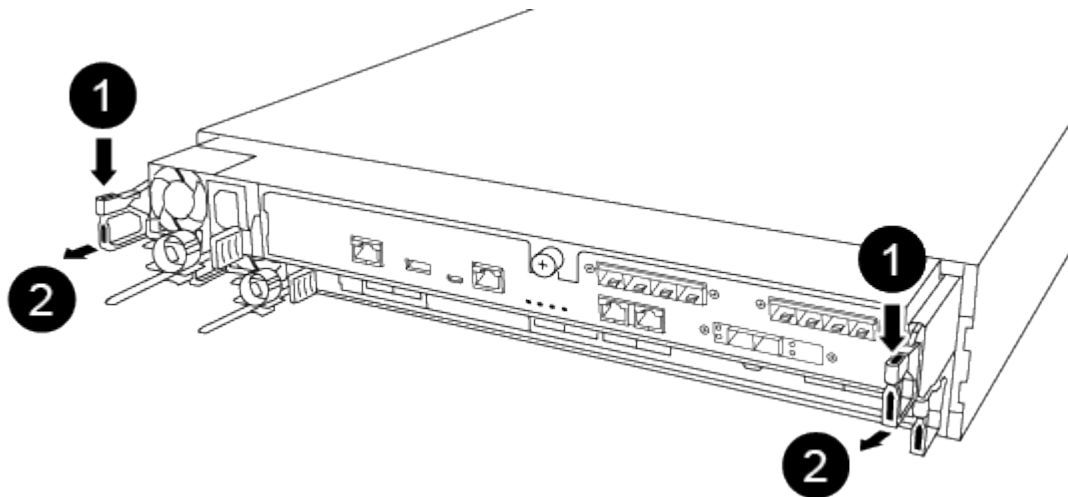

1	Lever
2	Latching mechanism

5. Using both hands, grasp the controller module sides and gently pull it out of the chassis and set it on a flat, stable surface.

6. Turn the thumbscrew on the front of the controller module anti-clockwise and open the controller module cover.

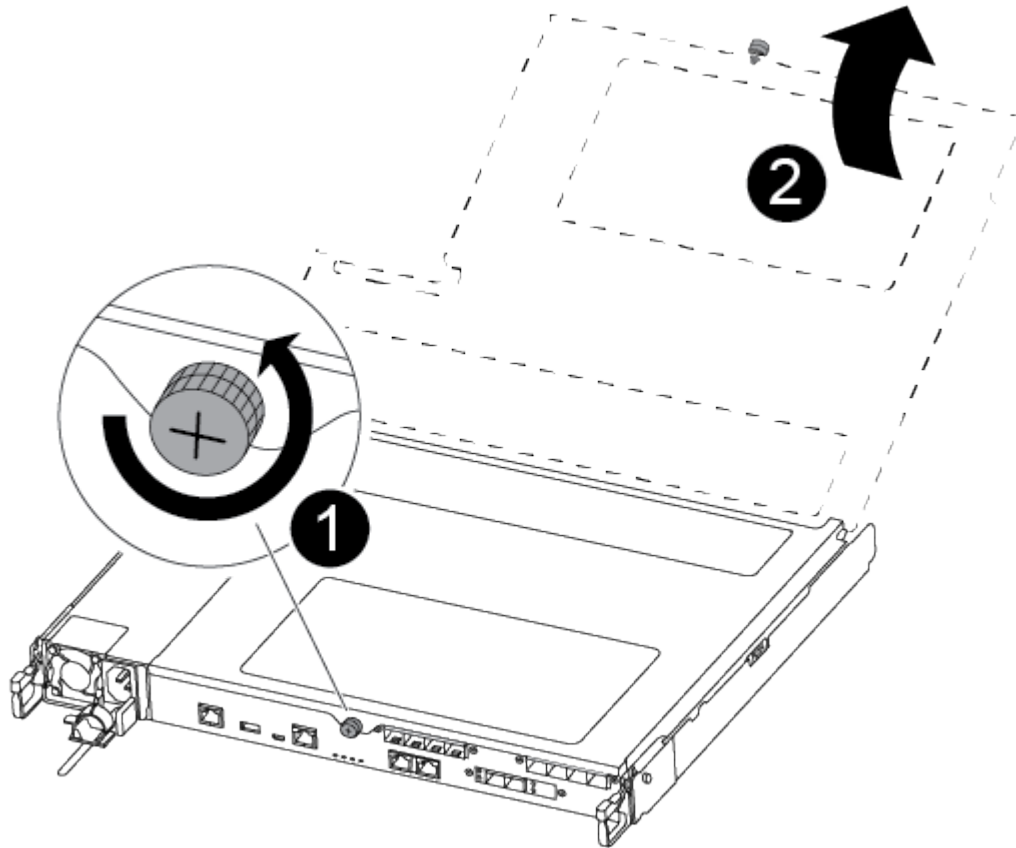

1	Thumbscrew
2	Controller module cover

### Step 3: Replace a fan

To replace a fan, remove the failed fan module and replace it with a new fan module.

Use the following video or the tabulated steps to replace a fan:

#### [Animation - Replace a fan](#)

1. Identify the fan module that you must replace by checking the console error messages or by locating the lit LED for the fan module on the motherboard.
2. Remove the fan module by pinching the side of the fan module, and then lifting the fan module straight out of the controller module.



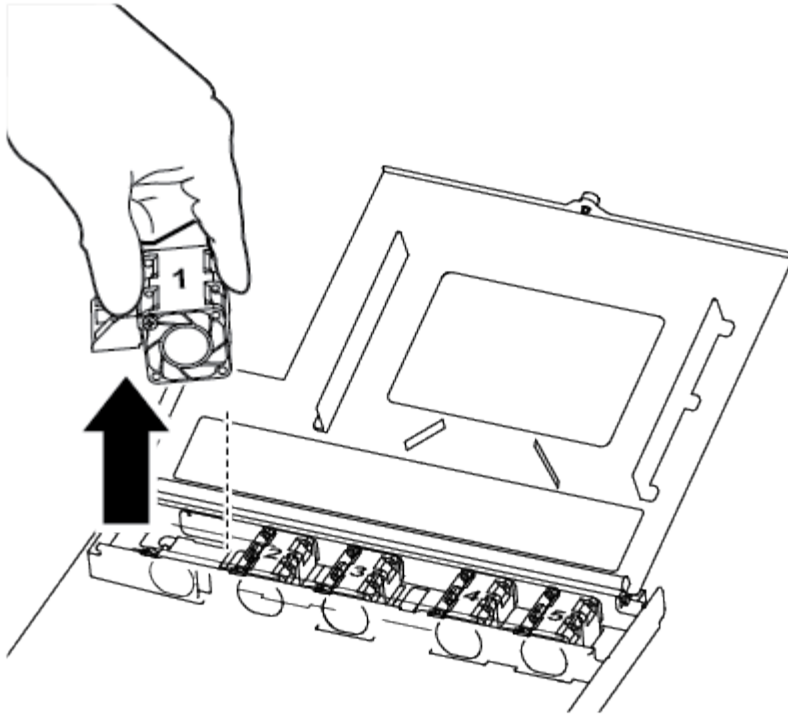

<b>1</b>	Fan module
----------	------------

3. Align the edges of the replacement fan module with the opening in the controller module, and then slide the replacement fan module into the controller module.

#### **Step 4: Reinstall the controller module**

After you replace a component within the controller module, you must reinstall the controller module in the system chassis and boot it.

1. Close the controller module cover and tighten the thumbscrew.

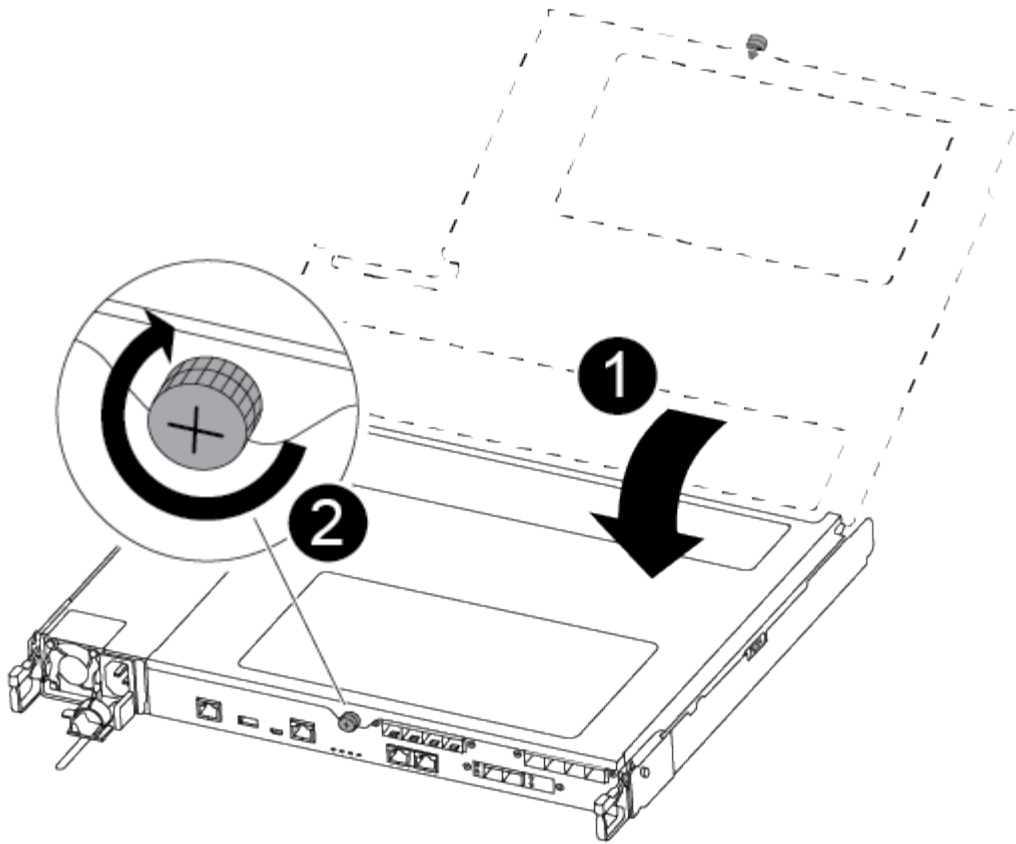

1	Controller module cover
2	Thumbscrew

2. Insert the controller module into the chassis:

- a. Ensure the latching mechanism arms are locked in the fully extended position.
- b. Using both hands, align and gently slide the controller module into the latching mechanism arms until it stops.
- c. Place your index fingers through the finger holes from the inside of the latching mechanism.
- d. Press your thumbs down on the orange tabs on top of the latching mechanism and gently push the controller module over the stop.
- e. Release your thumbs from the top of the latching mechanisms and continue pushing until the latching mechanisms snap into place.

The controller module begins to boot as soon as it is fully seated in the chassis. Be prepared to interrupt the boot process.

The controller module should be fully inserted and flush with the edges of the chassis.

3. Recable the system, as needed.

4. Return the controller to normal operation by giving back its storage: `storage failover giveback -ofnode impaired_node_name`

5. If automatic giveback was disabled, reenable it: 

```
storage failover modify -node local -auto-giveback true
```

### Step 5: Return the failed part to NetApp

Return the failed part to NetApp, as described in the RMA instructions shipped with the kit. See the [Part Return and Replacements](#) page for further information.

#### Replace or install a mezzanine card - ASA A250

To replace a failed mezzanine card, you must remove the cables and any SFP or QSFP modules, replace the card, reinstall the SFP or QSFP modules and recable the cards. To install a new mezzanine card, you must have the appropriate cables and SFP or QSFP modules.

#### About this task

- You can use this procedure with all versions of ONTAP supported by your system
- All other components in the system must be functioning properly; if not, you must contact technical support.

### Step 1: Shut down the impaired controller

To shut down the impaired controller, you must determine the status of the controller and, if necessary, take over the controller so that the healthy controller continues to serve data from the impaired controller storage.

#### About this task

- If you have a SAN system, you must have checked event messages (`cluster kernel-service show`) for the impaired controller SCSI blade. The `cluster kernel-service show` command (from `priv advanced mode`) displays the node name, quorum status of that node, availability status of that node, and operational status of that node.

Each SCSI-blade process should be in quorum with the other nodes in the cluster. Any issues must be resolved before you proceed with the replacement.

- If you have a cluster with more than two nodes, it must be in quorum. If the cluster is not in quorum or a healthy controller shows `false` for eligibility and health, you must correct the issue before shutting down the impaired controller; see [Synchronize a node with the cluster](#).

#### Steps

1. If AutoSupport is enabled, suppress automatic case creation by invoking an AutoSupport message:  

```
system node autosupport invoke -node * -type all -message MAINT=<# of hours>h
```

The following AutoSupport message suppresses automatic case creation for two hours: `cluster1:>`  

```
system node autosupport invoke -node * -type all -message MAINT=2h
```

2. Disable automatic giveback from the console of the healthy controller: 

```
storage failover modify -node local -auto-giveback false
```



When you see *Do you want to disable auto-giveback?*, enter *y*.

3. Take the impaired controller to the LOADER prompt:

If the impaired controller is displaying...	Then...
The LOADER prompt	Go to the next step.
Waiting for giveback...	Press Ctrl-C, and then respond <code>y</code> when prompted.
System prompt or password prompt	Take over or halt the impaired controller from the healthy controller: <pre>storage failover takeover -ofnode impaired_node_name</pre> When the impaired controller shows Waiting for giveback..., press Ctrl-C, and then respond <code>y</code> .

## Step 2: Remove the controller module

Remove the controller module from the chassis when you replace a component inside the controller module.

Make sure that you label the cables so that you know where they came from.

1. If you are not already grounded, properly ground yourself.
2. Unplug the controller module power supplies from the source.
3. Release the power cable retainers, and then unplug the cables from the power supplies.
4. Insert your forefinger into the latching mechanism on either side of the controller module, press the lever with your thumb, and gently pull the controller a few inches out of the chassis.



If you have difficulty removing the controller module, place your index fingers through the finger holes from the inside (by crossing your arms).

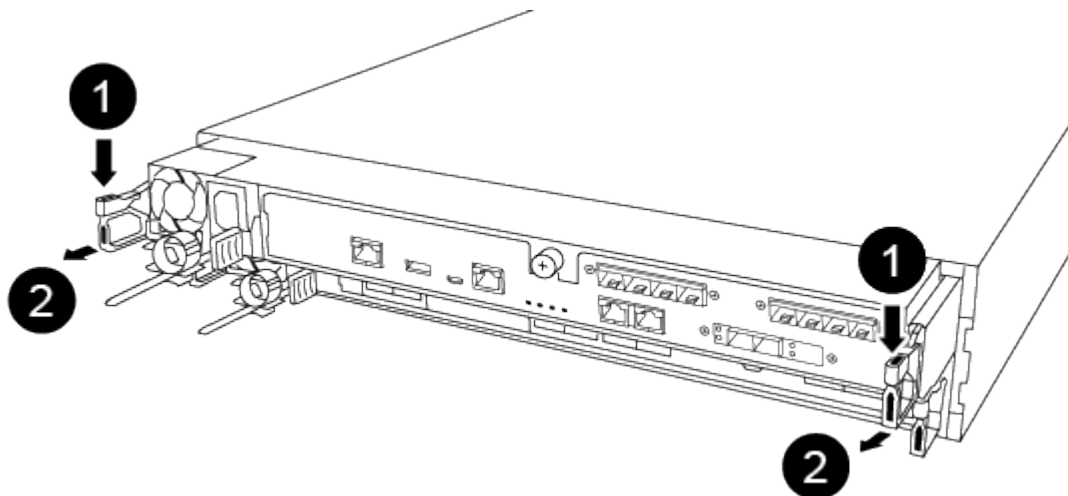

1	Lever
---	-------

2	Latching mechanism
---	--------------------

- Using both hands, grasp the controller module sides and gently pull it out of the chassis and set it on a flat, stable surface.
- Turn the thumbscrew on the front of the controller module anti-clockwise and open the controller module cover.

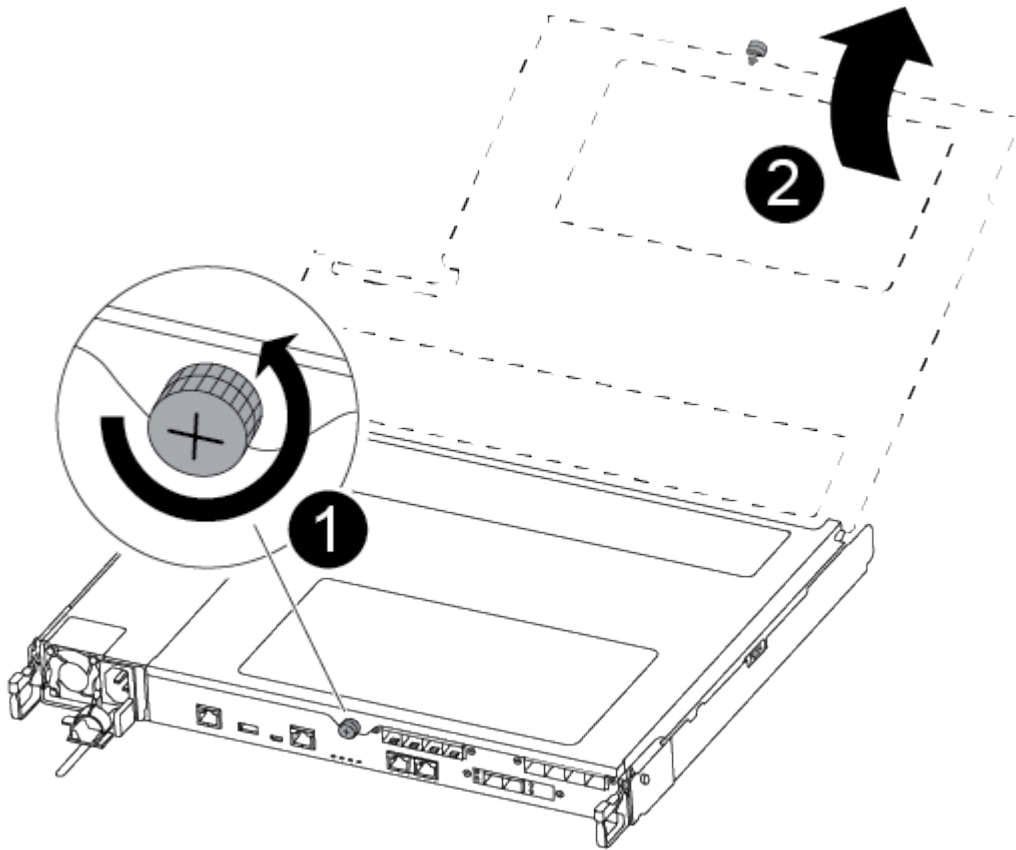

1	Thumbscrew
2	Controller module cover.

### Step 3: Replace or install a mezzanine card

To replace a mezzanine card, you must remove the impaired card and install the replacement card; to install a mezzanine card, you must remove the faceplate and install the new card.

Use the following video or the tabulated steps to replace a mezzanine card:

[Animation - Replace a mezzanine card](#)

- To replace a mezzanine card:
- Locate and replace the impaired mezzanine card on your controller module.

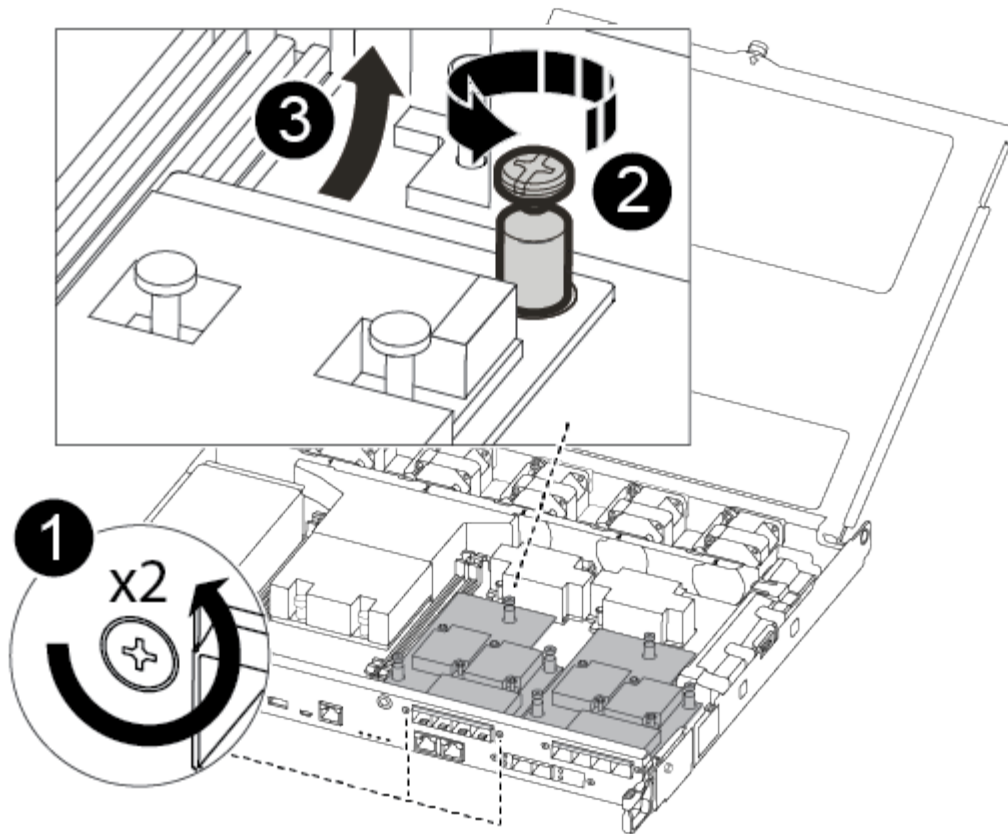

1	Remove screws on the face of the controller module.
2	Loosen the screw in the controller module.
3	Remove the mezzanine card.

a. Unplug any cabling associated with the impaired mezzanine card.

Make sure that you label the cables so that you know where they came from.

b. Remove any SFP or QSFP modules that might be in the impaired mezzanine card and set it aside.

c. Using the #1 magnetic screwdriver, remove the screws from the face of the controller module and set them aside safely on the magnet.

d. Using the #1 magnetic screwdriver, loosen the screw on the impaired mezzanine card.

e. Using the #1 magnetic screwdriver, gently lift the impaired mezzanine card directly out of the socket and set it aside.

f. Remove the replacement mezzanine card from the antistatic shipping bag and align it to the inside face of the controller module.

g. Gently align the replacement mezzanine card into place.

h. Using the #1 magnetic screwdriver, insert and tighten the screws on the face of the controller module and on the mezzanine card.



Do not apply force when tightening the screw on the mezzanine card; you might crack it.

- i. Insert any SFP or QSFP modules that were removed from the impaired mezzanine card to the replacement mezzanine card.

3. To install a mezzanine card:

4. You install a new mezzanine card if your system does not have one.

- a. Using the #1 magnetic screwdriver, remove the screws from the face of the controller module and the faceplate covering the mezzanine card slot, and set them aside safely on the magnet.
- b. Remove the mezzanine card from the antistatic shipping bag and align it to the inside face of the controller module.
- c. Gently align the mezzanine card into place.
- d. Using the #1 magnetic screwdriver, insert and tighten the screws on the face of the controller module and on the mezzanine card.



Do not apply force when tightening the screw on the mezzanine card; you might crack it.

#### Step 4: Reinstall the controller module

After you replace a component within the controller module, you must reinstall the controller module in the system chassis and boot it.

1. Close the controller module cover and tighten the thumbscrew.

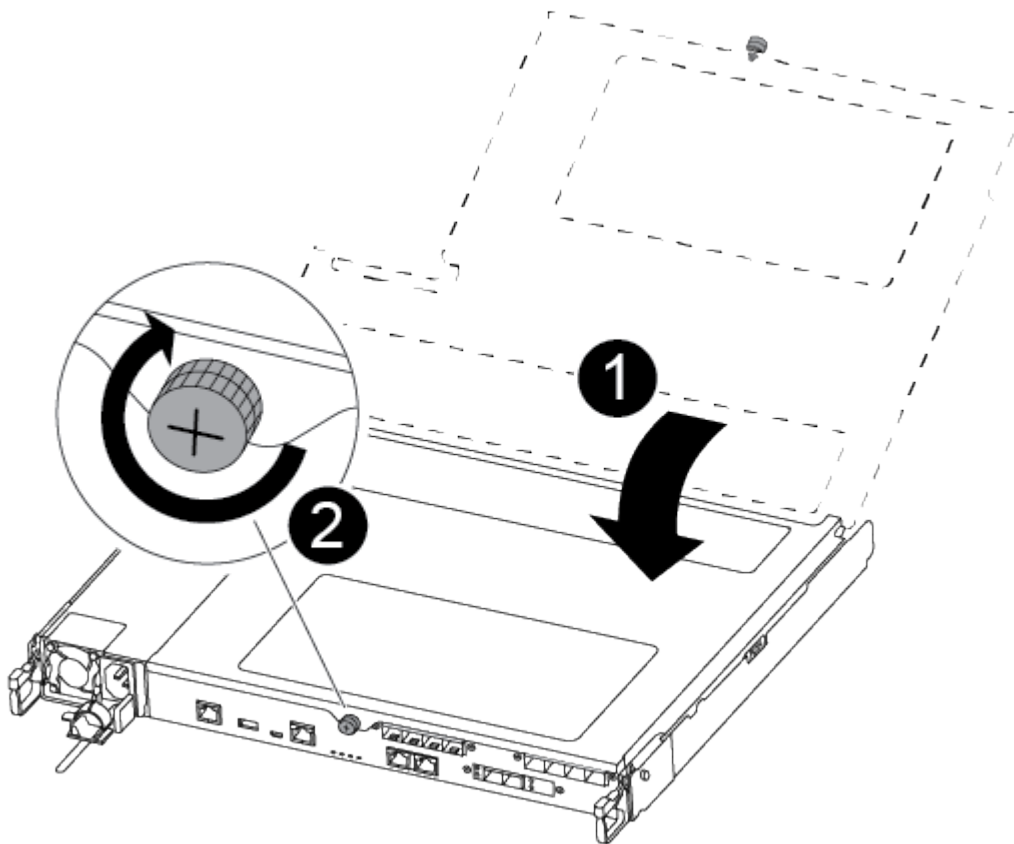

1	Controller module cover
2	Thumbscrew

2. Insert the controller module into the chassis:

- a. Ensure the latching mechanism arms are locked in the fully extended position.
- b. Using both hands, align and gently slide the controller module into the latching mechanism arms until it stops.
- c. Place your index fingers through the finger holes from the inside of the latching mechanism.
- d. Press your thumbs down on the orange tabs on top of the latching mechanism and gently push the controller module over the stop.
- e. Release your thumbs from the top of the latching mechanisms and continue pushing until the latching mechanisms snap into place.

The controller module begins to boot as soon as it is fully seated in the chassis. Be prepared to interrupt the boot process.

The controller module should be fully inserted and flush with the edges of the chassis.

3. Recable the system, as needed.

4. Return the controller to normal operation by giving back its storage: `storage failover giveback -ofnode impaired_node_name`

5. If automatic giveback was disabled, reenable it: `storage failover modify -node local -auto -giveback true`

### Step 5: Return the failed part to NetApp

Return the failed part to NetApp, as described in the RMA instructions shipped with the kit. See the [Part Return and Replacements](#) page for further information.

#### Replace the NVMEM battery - ASA A250

To replace an NVMEM battery in the system, you must remove the controller module from the system, open it, replace the battery, and close and replace the controller module.

All other components in the system must be functioning properly; if not, you must contact technical support.

### Step 1: Shut down the impaired controller

To shut down the impaired controller, you must determine the status of the controller and, if necessary, take over the controller so that the healthy controller continues to serve data from the impaired controller storage.

#### About this task

- If you have a SAN system, you must have checked event messages (`cluster kernel-service show`) for the impaired controller SCSI blade. The `cluster kernel-service show` command (from `priv advanced mode`) displays the node name, quorum status of that node, availability status of that node, and operational status of that node.



Each SCSI-blade process should be in quorum with the other nodes in the cluster. Any issues must be resolved before you proceed with the replacement.

- If you have a cluster with more than two nodes, it must be in quorum. If the cluster is not in quorum or a healthy controller shows false for eligibility and health, you must correct the issue before shutting down the impaired controller; see [Synchronize a node with the cluster](#).

### Steps

1. If AutoSupport is enabled, suppress automatic case creation by invoking an AutoSupport message:  
`system node autosupport invoke -node * -type all -message MAINT=<# of hours>h`

The following AutoSupport message suppresses automatic case creation for two hours: `cluster1:>`  
`system node autosupport invoke -node * -type all -message MAINT=2h`

2. Disable automatic giveback from the console of the healthy controller: `storage failover modify -node local -auto-giveback false`



When you see *Do you want to disable auto-giveback?*, enter *y*.

3. Take the impaired controller to the LOADER prompt:

If the impaired controller is displaying...	Then...
The LOADER prompt	Go to the next step.
Waiting for giveback...	Press Ctrl-C, and then respond <i>y</i> when prompted.
System prompt or password prompt	Take over or halt the impaired controller from the healthy controller: <code>storage failover takeover -ofnode <i>impaired_node_name</i></code>  When the impaired controller shows Waiting for giveback..., press Ctrl-C, and then respond <i>y</i> .

### Step 2: Remove the controller module

You must remove the controller module from the chassis when you replace a component inside the controller module.

Make sure that you label the cables so that you know where they came from.

1. If you are not already grounded, properly ground yourself.
2. Unplug the controller module power supplies from the source.
3. Release the power cable retainers, and then unplug the cables from the power supplies.
4. Insert your forefinger into the latching mechanism on either side of the controller module, press the lever with your thumb, and gently pull the controller a few inches out of the chassis.



If you have difficulty removing the controller module, place your index fingers through the finger holes from the inside (by crossing your arms).

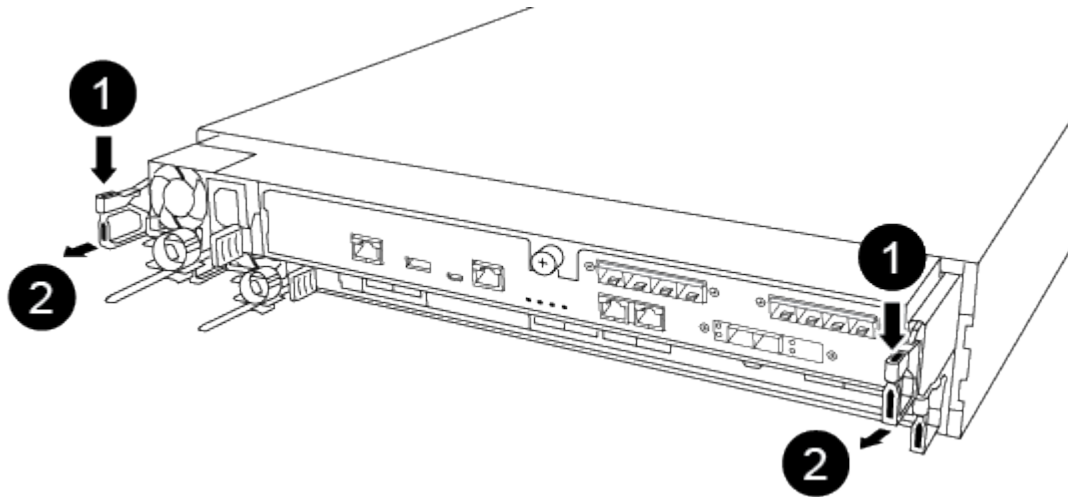

1	Lever
2	Latching mechanism

- Using both hands, grasp the controller module sides and gently pull it out of the chassis and set it on a flat, stable surface.
- Turn the thumbscrew on the front of the controller module anti-clockwise and open the controller module cover.

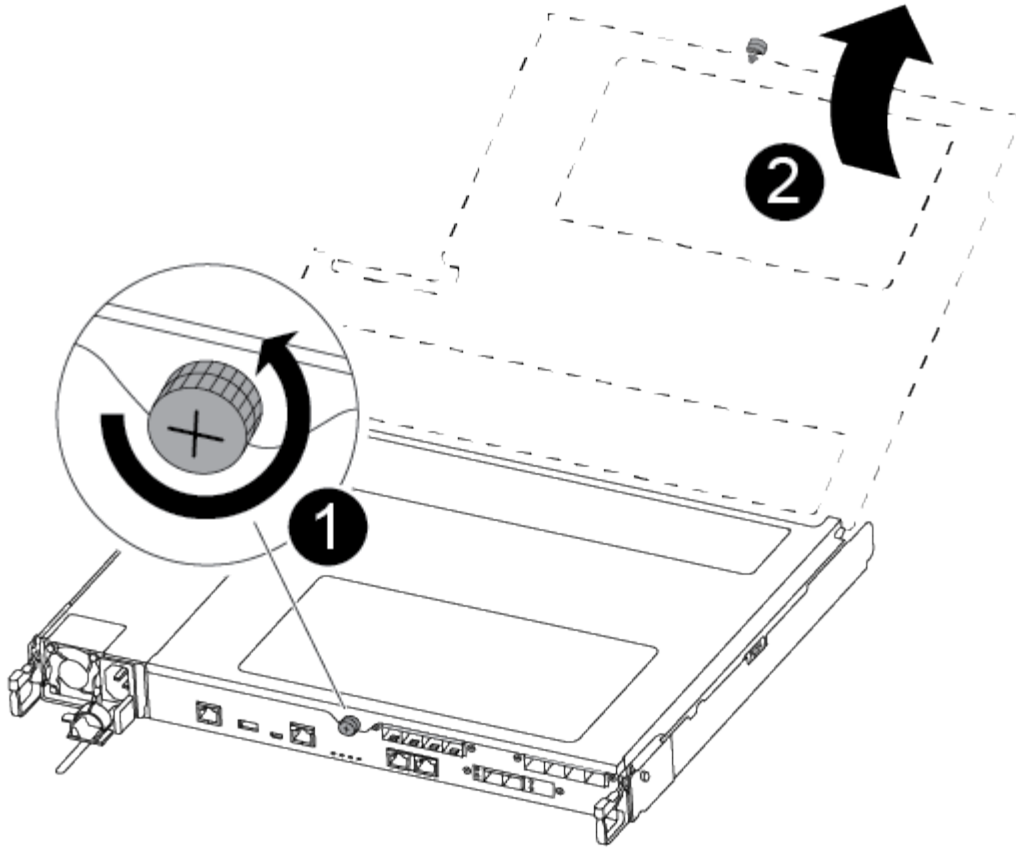

1	Thumbscrew
2	Controller module cover.

### Step 3: Replace the NVMEM battery

To replace the NVMEM battery, you must remove the failed battery from the controller module and install the replacement battery into the controller module.

Use the following video or the tabulated steps to replace the NVMEM battery:

[Animation - Replace the NVMEM battery](#)

1. Locate and replace the impaired NVMEM battery on your controller module.



It is recommended that you follow the illustrated instructions in the order listed.

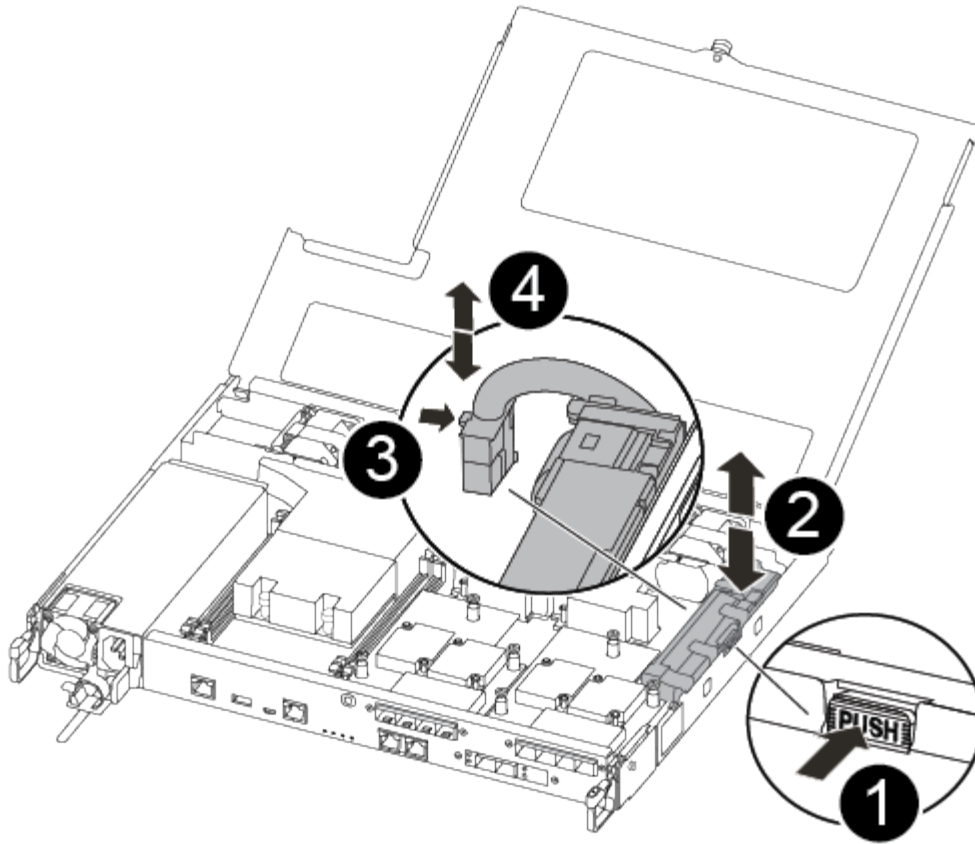

1	Squeeze the clip on the face of the battery plug.
2	Unplug the battery cable from the socket.
3	Grasp the battery and press the blue locking tab marked PUSH.
4	Lift the battery out of the holder and controller module.

2. Locate the battery plug and squeeze the clip on the face of the battery plug to release the plug from the socket.
3. Grasp the battery and press the blue locking tab marked PUSH, and then lift the battery out of the holder and controller module and set it aside.
4. Remove the replacement NV battery from the antistatic shipping bag and align it to the battery holder.
5. Insert the replacement NV battery plug into the socket.
6. Slide the battery pack down along the sheet metal side wall until the support tabs on the side wall hook into the slots on the battery pack, and the battery pack latch engages and clicks into the opening on the side wall.
7. Press firmly down on the battery pack to make sure that it is locked into place.

#### Step 4: Install the controller module

After you have replaced the component in the controller module, you must reinstall the controller module into the chassis, and then boot it.

You can use the following illustration or the written steps to install the replacement controller module in the chassis.

1. Close the controller module cover and tighten the thumbscrew.

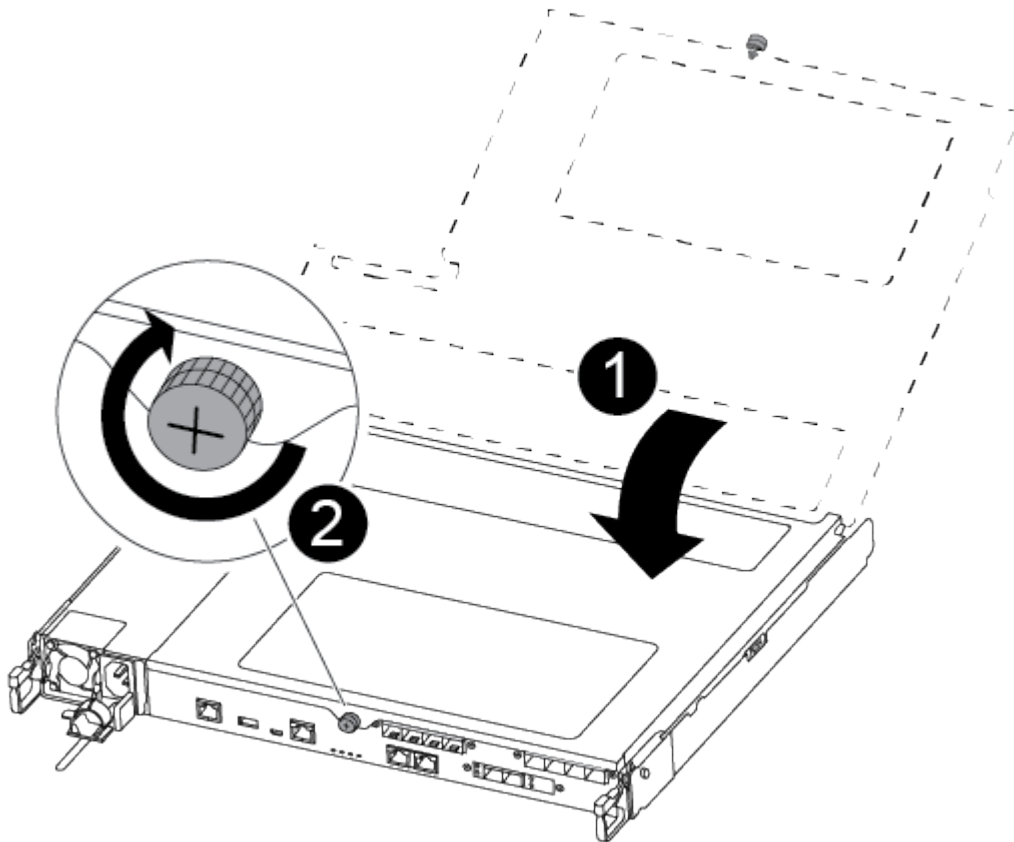

1	Controller module cover
2	Thumbscrew

2. Insert the controller module into the chassis:

- a. Ensure the latching mechanism arms are locked in the fully extended position.
- b. Using both hands, align and gently slide the controller module into the latching mechanism arms until it stops.
- c. Place your index fingers through the finger holes from the inside of the latching mechanism.
- d. Press your thumbs down on the orange tabs on top of the latching mechanism and gently push the controller module over the stop.
- e. Release your thumbs from the top of the latching mechanisms and continue pushing until the latching mechanisms snap into place.

The controller module begins to boot as soon as it is fully seated in the chassis.

The controller module should be fully inserted and flush with the edges of the chassis.

3. Cable the management and console ports only, so that you can access the system to perform the tasks in the following sections.



You will connect the rest of the cables to the controller module later in this procedure.

### Step 5: Return the failed part to NetApp

Return the failed part to NetApp, as described in the RMA instructions shipped with the kit. See the [Part Return and Replacements](#) page for further information.

#### Replace a power supply - ASA A250

Replacing a power supply (PSU) involves disconnecting the target PSU from the power source, unplugging the power cable, removing the old PSU and installing the replacement PSU, and then reconnecting it to the power source.

- The power supplies are redundant and hot-swappable.
- This procedure is written for replacing one PSU at a time.



It is a best practice to replace the PSU within two minutes of removing it from the chassis. The system continues to function, but ONTAP sends messages to the console about the degraded PSU until the PSU is replaced.

- Power supplies are auto-ranging.



Do not mix PSUs with different efficiency ratings. Always replace like for like.

Use the appropriate procedure for your type of PSU; AC or DC.

### Option 1: Replace an AC PSU

Use the following video or the tabulated steps to replace the PSU:

#### Animation - Replace the AC PSU

1. If you are not already grounded, properly ground yourself.
2. Identify the PSU you want to replace, based on console error messages or through the red Fault LED on the PSU.
3. Disconnect the PSU:
  - a. Open the power cable retainer, and then unplug the power cable from the PSU.
4. Remove the PSU by rotating the handle up, press the locking tab, and then pull the PSU out of the controller module.



The PSU is short. Always use two hands to support it when removing it from the controller module so that it does not suddenly swing free from the controller module and injure you.

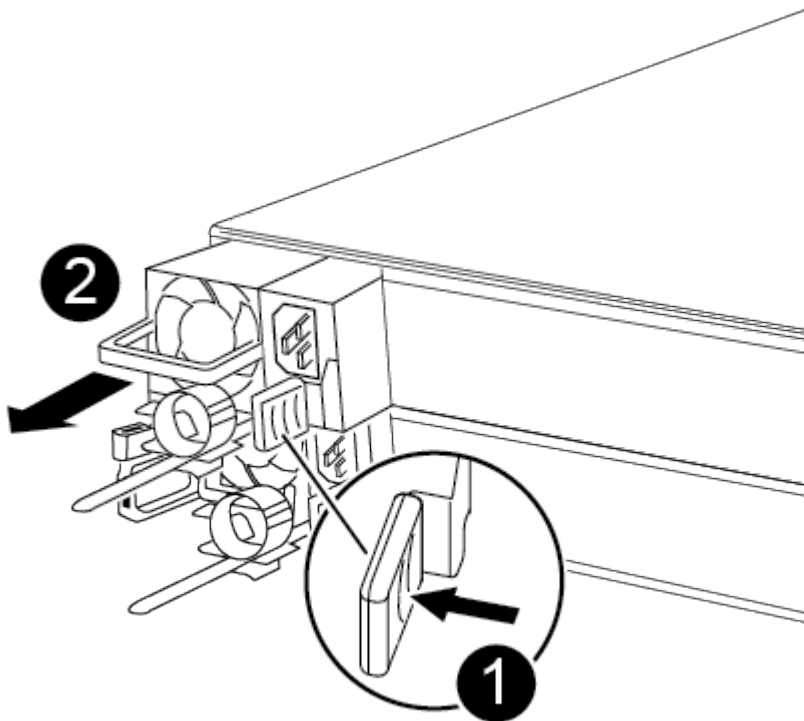

<b>1</b>	Blue PSU locking tab
<b>2</b>	Power supply

5. Install the replacement PSU in the controller module:
  - a. Using both hands, support and align the edges of the PSU with the opening in the controller module.

- b. Gently push the PSU into the controller module until the locking tab clicks into place.

The power supplies will only properly engage with the internal connector and lock in place one way.



To avoid damaging the internal connector, do not use excessive force when sliding the PSU into the system.

6. Reconnect the PSU cabling:
  - a. Reconnect the power cable to the PSU.
  - b. Secure the power cable to the PSU using the power cable retainer.

Once power is restored to the PSU, the status LED should be green.

7. Return the failed part to NetApp, as described in the RMA instructions shipped with the kit. See the [Part Return and Replacements](#) page for further information.

### Option 2: Replace a DC PSU

To replace a DC PSU, complete the following steps.

1. If you are not already grounded, properly ground yourself.
2. Identify the PSU you want to replace, based on console error messages or through the red Fault LED on the PSU.
3. Disconnect the PSU:
  - a. Unscrew the D-SUB DC power cable connector using the thumb screws on the plug.
  - b. Unplug the power cable from the PSU and set it aside.
4. Remove the PSU by rotating the handle up, press the locking tab, and then pull PSU out of the controller module.



The PSU is short. Always use two hands to support it when removing it from the controller module so that it does not suddenly swing free from the controller module and injure you.

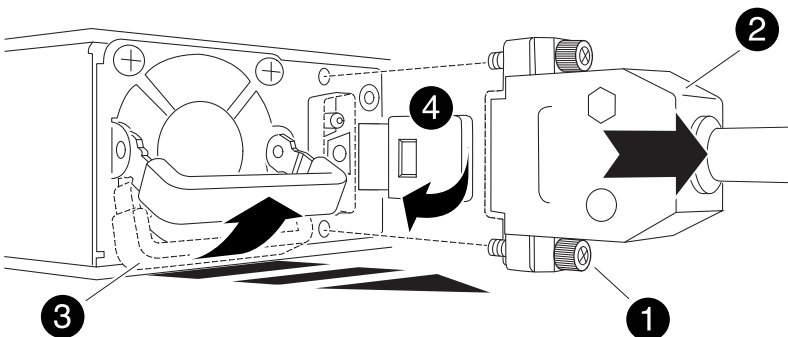

1	Thumb screws
2	D-SUB DC power cable connector



3	Power supply handle
4	Blue PSU locking tab

5. Install the replacement PSU in the controller module:

- a. Using both hands, support and align the edges of the PSU with the opening in the controller module.
- b. Gently push the PSU into the controller module until the locking tab clicks into place.

The power supplies will only properly engage with the internal connector and lock in place one way.



To avoid damaging the internal connector, do not use excessive force when sliding the PSU into the system.

6. Reconnect the D-SUB DC power cable:

- a. Plug the power cable connector into the PSU.
- b. Secure the power cable to the PSU with the thumbscrews.

Once power is restored to the PSU, the status LED should be green.

7. Return the failed part to NetApp, as described in the RMA instructions shipped with the kit. See the [Part Return and Replacements](#) page for further information.

### Replace the real-time clock battery - ASA A250

You replace the real-time clock (RTC) battery in the controller module so that your system's services and applications that depend on accurate time synchronization continue to function.

- You can use this procedure with all versions of ONTAP supported by your system
- All other components in the system must be functioning properly; if not, you must contact technical support.

#### Step 1: Shut down the impaired controller

To shut down the impaired controller, you must determine the status of the controller and, if necessary, take over the controller so that the healthy controller continues to serve data from the impaired controller storage.

#### About this task

- If you have a SAN system, you must have checked event messages (`cluster kernel-service show`) for the impaired controller SCSI blade. The `cluster kernel-service show` command (from `priv advanced mode`) displays the node name, quorum status of that node, availability status of that node, and operational status of that node.

Each SCSI-blade process should be in quorum with the other nodes in the cluster. Any issues must be resolved before you proceed with the replacement.

- If you have a cluster with more than two nodes, it must be in quorum. If the cluster is not in quorum or a

healthy controller shows false for eligibility and health, you must correct the issue before shutting down the impaired controller; see [Synchronize a node with the cluster](#).

## Steps

1. If AutoSupport is enabled, suppress automatic case creation by invoking an AutoSupport message:  
`system node autosupport invoke -node * -type all -message MAINT=<# of hours>h`

The following AutoSupport message suppresses automatic case creation for two hours: `cluster1:>`  
`system node autosupport invoke -node * -type all -message MAINT=2h`

2. Disable automatic giveback from the console of the healthy controller: `storage failover modify -node local -auto-giveback false`



When you see *Do you want to disable auto-giveback?*, enter *y*.

3. Take the impaired controller to the LOADER prompt:

If the impaired controller is displaying...	Then...
The LOADER prompt	Go to the next step.
Waiting for giveback...	Press Ctrl-C, and then respond <i>y</i> when prompted.
System prompt or password prompt	Take over or halt the impaired controller from the healthy controller: <code>storage failover takeover -ofnode impaired_node_name</code>  When the impaired controller shows Waiting for giveback..., press Ctrl-C, and then respond <i>y</i> .

## Step 2: Remove the controller module

You must remove the controller module from the chassis when you replace a component inside the controller module.

Make sure that you label the cables so that you know where they came from.

1. If you are not already grounded, properly ground yourself.
2. Unplug the controller module power supplies from the source.
3. Release the power cable retainers, and then unplug the cables from the power supplies.
4. Insert your forefinger into the latching mechanism on either side of the controller module, press the lever with your thumb, and gently pull the controller a few inches out of the chassis.



If you have difficulty removing the controller module, place your index fingers through the finger holes from the inside (by crossing your arms).

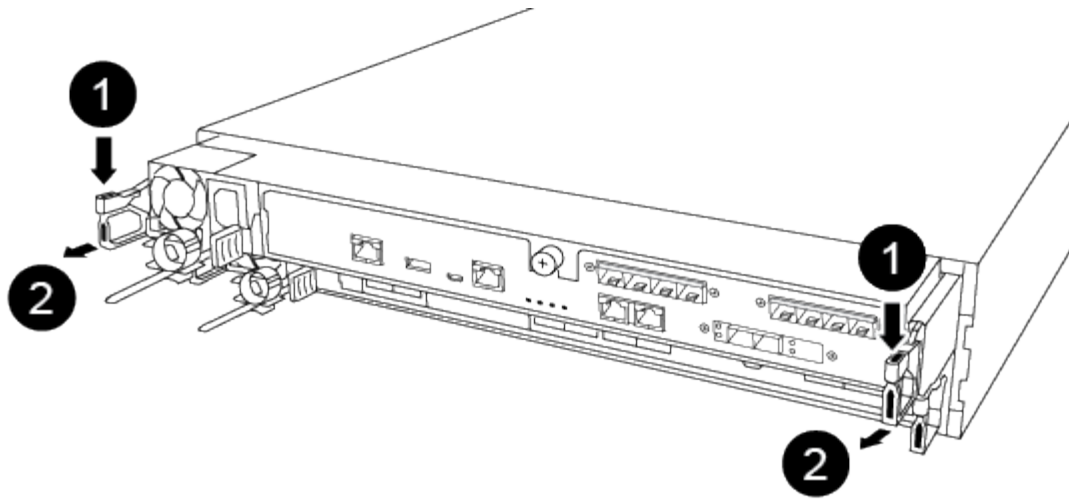

1	Lever
2	Latching mechanism

5. Using both hands, grasp the controller module sides and gently pull it out of the chassis and set it on a flat, stable surface.
6. Turn the thumbscrew on the front of the controller module anti-clockwise and open the controller module cover.

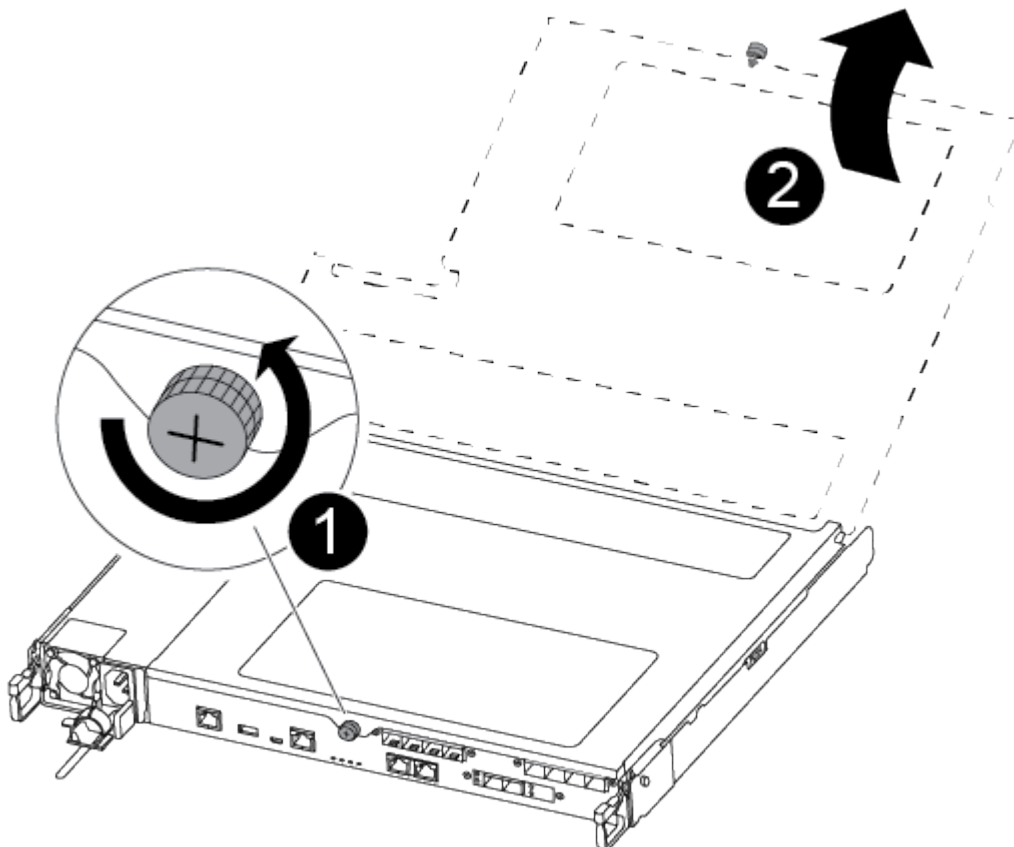

1	Thumbscrew
2	Controller module cover.

7. Lift out the air duct cover.

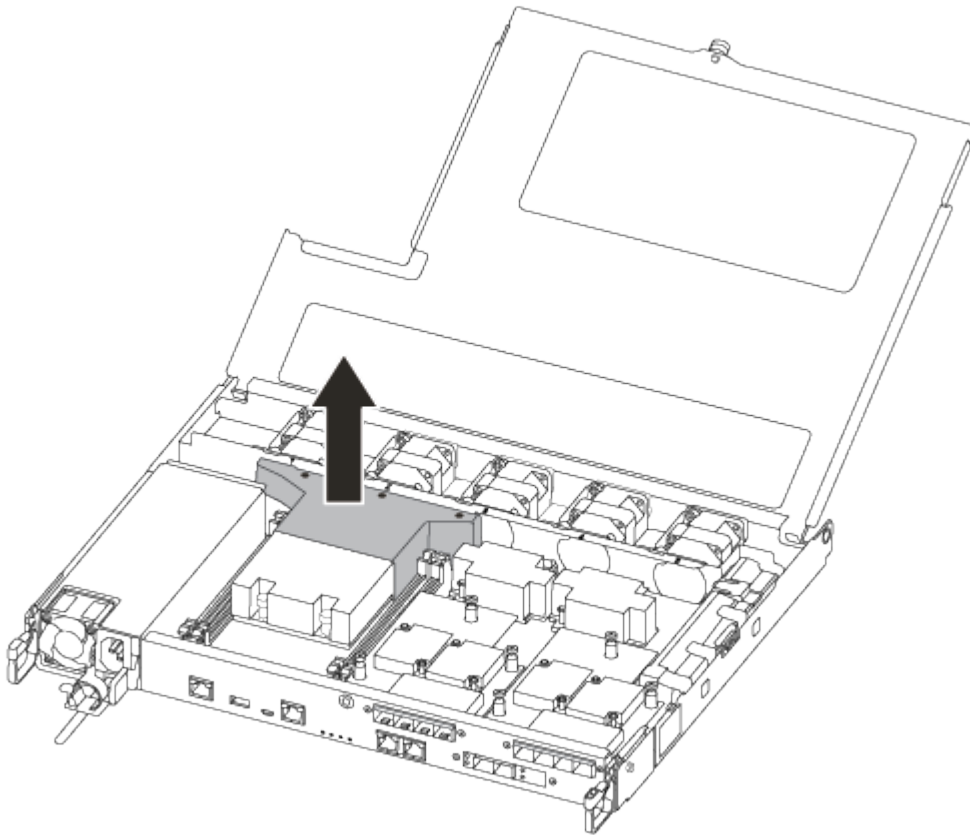

### Step 3: Replace the RTC battery

To replace the RTC battery, locate it inside the controller and follow the specific sequence of steps.

Use the following video or the tabulated steps to replace the RTC battery:

[Animation - Replace the RTC battery](#)

1. Locate the RTC battery between the heatsink and the midplane and remove it exactly as shown in the graphic.

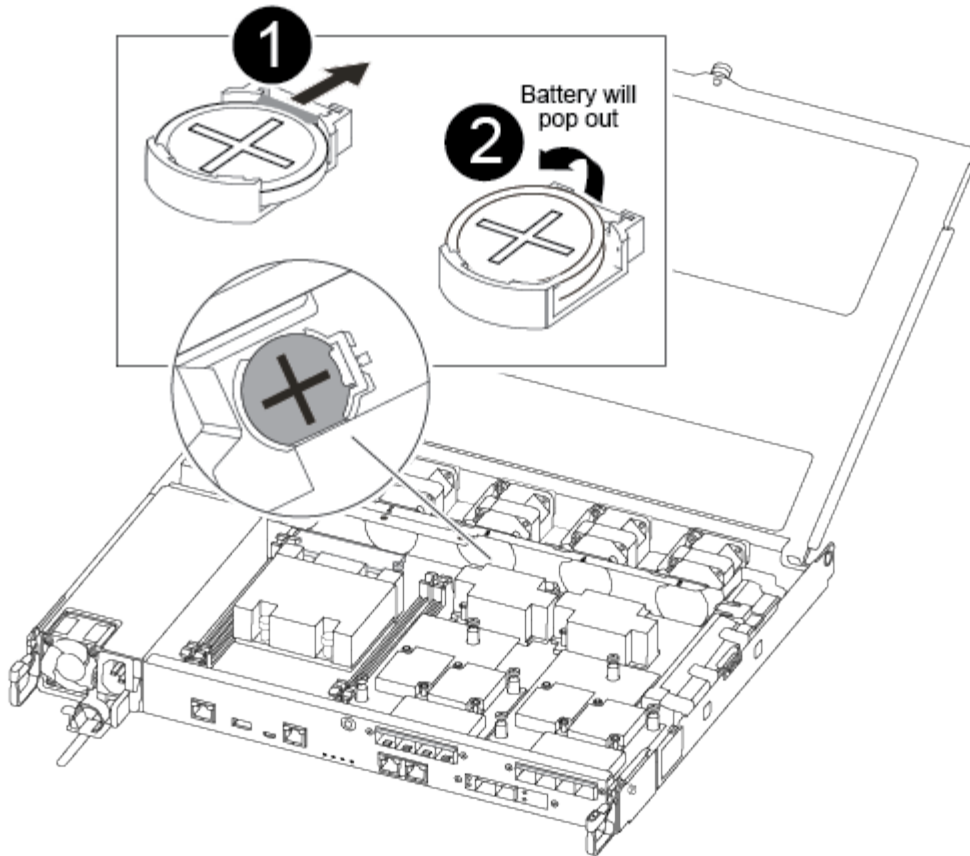

<p><b>1</b></p>	<p>Gently pull tab away from the battery housing.  <b>Attention:</b> Pulling it away aggressively might displace the tab.</p>
<p><b>2</b></p>	<p>Lift the battery up.  <b>Note:</b> Make a note of the polarity of the battery.</p>
<p><b>3</b></p>	<p>The battery should eject out.</p>

The battery will be ejected out.

2. Remove the replacement battery from the antistatic shipping bag.
3. Locate the RTC battery holder between the heatsink and the midplane and insert it exactly as shown in the graphic.

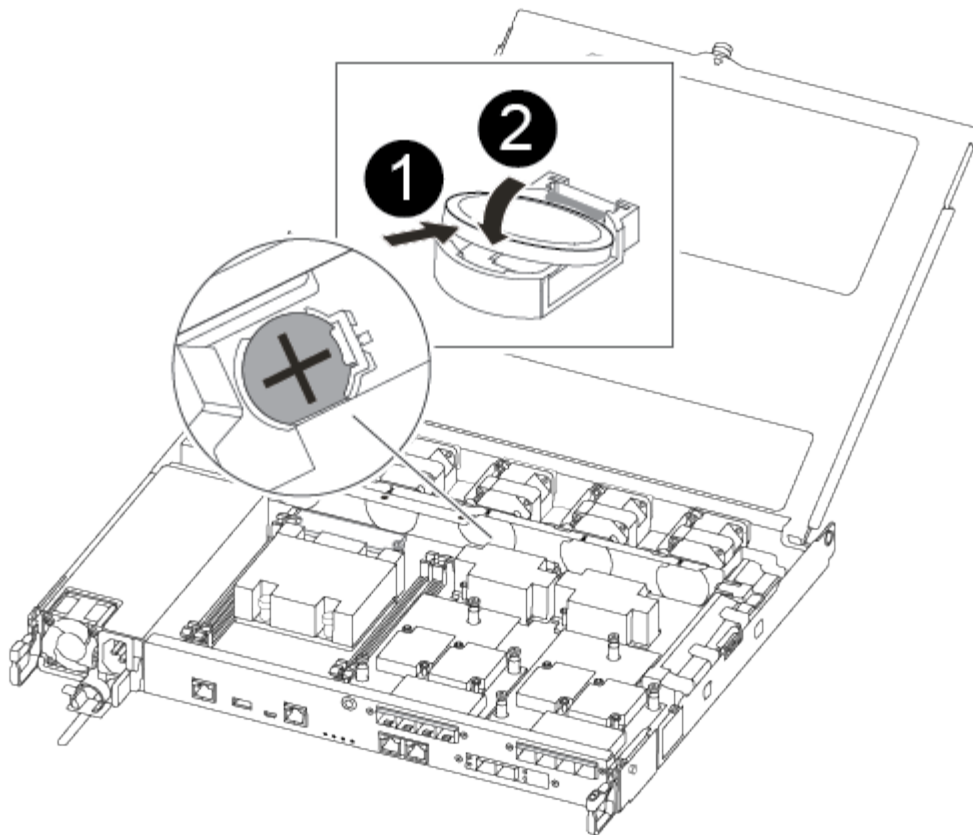

<p><b>1</b></p>	<p>With positive polarity face up, slide the battery under the tab of the battery housing.</p>
<p><b>2</b></p>	<p>Push the battery gently into place and make sure the tab secures it to the housing.</p> <p> Pushing it in aggressively might cause the battery to eject out again.</p>

4. Visually inspect the battery to make sure that it is completely installed into the holder and that the polarity is correct.

#### Step 4: Reinstall the controller module and setting time/date after RTC battery replacement

After you replace a component within the controller module, you must reinstall the controller module in the system chassis, reset the time and date on the controller, and then boot it.

1. If you have not already done so, close the air duct or controller module cover.
2. Align the end of the controller module with the opening in the chassis, and then gently push the controller module halfway into the system.

Do not completely insert the controller module in the chassis until instructed to do so.

3. Recable the system, as needed.

If you removed the media converters (QSFPs or SFPs), remember to reinstall them if you are using fiber

optic cables.

4. If the power supplies were unplugged, plug them back in and reinstall the power cable retainers.
5. Insert the controller module into the chassis:
  - a. Ensure the latching mechanism arms are locked in the fully extended position.
  - b. Using both hands, align and gently slide the controller module into the latching mechanism arms until it stops.
  - c. Place your index fingers through the finger holes from the inside of the latching mechanism.
  - d. Press your thumbs down on the orange tabs on top of the latching mechanism and gently push the controller module over the stop.
  - e. Release your thumbs from the top of the latching mechanisms and continue pushing until the latching mechanisms snap into place.

The controller module begins to boot as soon as it is fully seated in the chassis. Be prepared to interrupt the boot process.

- f. Halt the controller at the `LOADER` prompt.

The controller module should be fully inserted and flush with the edges of the chassis.

6. Reset the time and date on the controller:
  - a. Check the date and time on the healthy controller with the `show date` command.
  - b. At the `LOADER` prompt on the target controller, check the time and date.
  - c. If necessary, modify the date with the `set date mm/dd/yyyy` command.
  - d. If necessary, set the time, in GMT, using the `set time hh:mm:ss` command.
  - e. Confirm the date and time on the target controller.
7. At the `LOADER` prompt, enter `bye` to reinitialize the PCIe cards and other components and let the controller reboot.
8. Return the controller to normal operation by giving back its storage: `storage failover giveback -ofnode impaired_node_name`
9. If automatic giveback was disabled, reenable it: `storage failover modify -node local -auto -giveback true`

## Step 5: Return the failed part to NetApp

Return the failed part to NetApp, as described in the RMA instructions shipped with the kit. See the [Part Return and Replacements](#) page for further information.

## ASA A400 systems

### Install and setup

**Start here:** Choose your installation and setup experience

For most configurations, you can choose from different content formats.

- [Quick steps](#)

A printable PDF of step-by-step instructions with live links to additional content.

- [Video steps](#)

Video step-by-step instructions.

- [Detailed steps](#)

Online step-by-step instructions with live links to additional content.

For MetroCluster configurations, see either:

- [Install MetroCluster IP configuration](#)
- [Install MetroCluster Fabric-Attached configuration](#)

#### Quick guide - ASA A400

The Installation and Setup instructions give graphic instructions for a typical installation of your system, from racking and cabling, through initial system bring-up. Use this guide if you are familiar with installing NetApp systems.

Use the links: [AFF A400 Installation and Setup Instructions](#).



The ASA A400 uses the same installation procedure as the AFF A400 system.

#### Video steps - ASA A400

The following video shows how to install and cable your new system.

[Animation - AFF A400 Installation and setup instructions](#)



The ASA A400 uses the same installation procedure as the AFF A400 system.

#### Detailed guide - ASA A400

This page provides detailed step-by-step instructions for installing a typical NetApp system. Use this guide if you want more detailed installation instructions.

#### Step 1: Prepare for installation

To install your system, you need to create an account, register the system, and get license keys. You also need to inventory the appropriate number and type of cables for your system and collect specific network information.

#### Before you begin

You need to have access to the Hardware Universe for information about site requirements as well as additional information on your configured system. You might also want to have access to the Release Notes for your version of ONTAP for more information about this system.

[NetApp Hardware Universe](#)

[Find the Release Notes for your version of ONTAP 9](#)



You need to provide the following at your site:

- Rack space for the storage system
- Phillips #2 screwdriver
- Additional networking cables to connect your system to your network switch and laptop or console with a Web browser

### Steps





1. Unpack the contents of all boxes.
2. Record the system serial number from the controllers.







3. Inventory and make a note of the number and types of cables you received.

The following table identifies the types of cables you might receive. If you receive a cable not listed in the table, see the Hardware Universe to locate the cable and identify its use.

[NetApp Hardware Universe](#)

Type of cable...	Part number and length	Connector type	For...
100 GbE cable (QSFP28)	X66211A-05 (112-00595), 0.5m X66211A-1 (112-00573), 1m X66211A-2 (112-00574), 2m X66211A-5 (112-00574), 5m		Storage, cluster interconnect/HA, and Ethernet data (order-dependent)
25 GbE cable (SFP28s)	X66240-2 (112-00598), 2m X66240-5 (112-00639), 5m		GbE network connection (order-dependent)
32 Gb FC (SFP+ Op)	X66250-2 (112-00342), 2m X66250-5 (112-00344), 5m X66250-15 (112-00346), 15m		FC network connection
Storage Cables	X66030A (112-00435), .5m X66031A (112-00436), 1m X66032A (112-00437), 2m X66033A (112-00438), 3m		mini-SAS HD to mini-SAS HD cables (order-dependent)

Type of cable...	Part number and length	Connector type	For...
Optical cables	X66250-2-N-C (112-00342)		16 Gb FC or 25GbE cables for mezzanine cards (order-dependent)
RJ-45 (order dependent)	X6585-R6 (112-00291), 3m X6562-R6 (112-00196), 5m		Management network
Micro-USB console cable	Not applicable		Console connection used during software setup if laptop or console does not support network discovery.
Power cables	Not applicable		Powering up the system

4. Review the *NetApp ONTAP Configuration Guide* and collect the required information listed in that guide.

[ONTAP Configuration Guide](#)

## Step 2: Install the hardware

You need to install your system in a 4-post rack or NetApp system cabinet, as applicable.

1. Install the rail kits, as needed.
2. Install and secure your system using the instructions included with the rail kit.



You need to be aware of the safety concerns associated with the weight of the system.

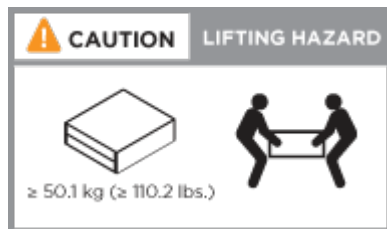

3. Attach cable management devices (as shown).

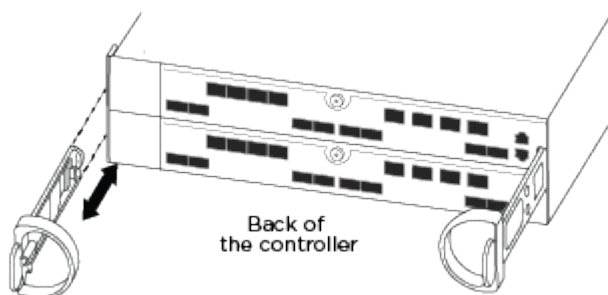

4. Place the bezel on the front of the system.

### Step 3: Cable controllers to your network

You can cable the controllers to your network by using the two-node switchless cluster method or by using the cluster interconnect network.



If the port labels on the card are not visible, check the card installation orientation (the PCIe connector socket is on the left side of the card slot in the A400 and FAS8300/8700), and then look for the card, by part number, in the [NetApp Hardware Universe](#) for a graphic of the bezel which will show the port labels. The card part number can be found using the `sysconfig -a` command or on the system packing list.



If you are cabling an MetroCluster IP configuration, ports e0a/e0b are available for hosting data LIFs (usually in Default IPspace).

#### Option 1: Cable a two-node switchless cluster

The optional data ports, optional NIC cards, and management ports on the controller modules are connected to switches. The cluster interconnect and HA ports are cabled on both controller modules.

You must have contacted your network administrator for information about connecting the system to the switches.

Be sure to check the direction of the cable pull-tabs when inserting the cables in the ports. Cable pull-tabs are up for all onboard ports and down for expansion (NIC) cards.

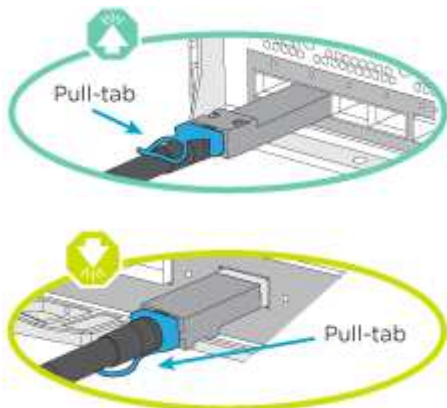

As you insert the connector, you should feel it click into place; if you do not feel it click, remove it, turn it around and try again.

#### Steps

1. Use the animation or illustration to complete the cabling between the controllers and to the switches:

[Animation - Two-node switchless cluster cabling](#)

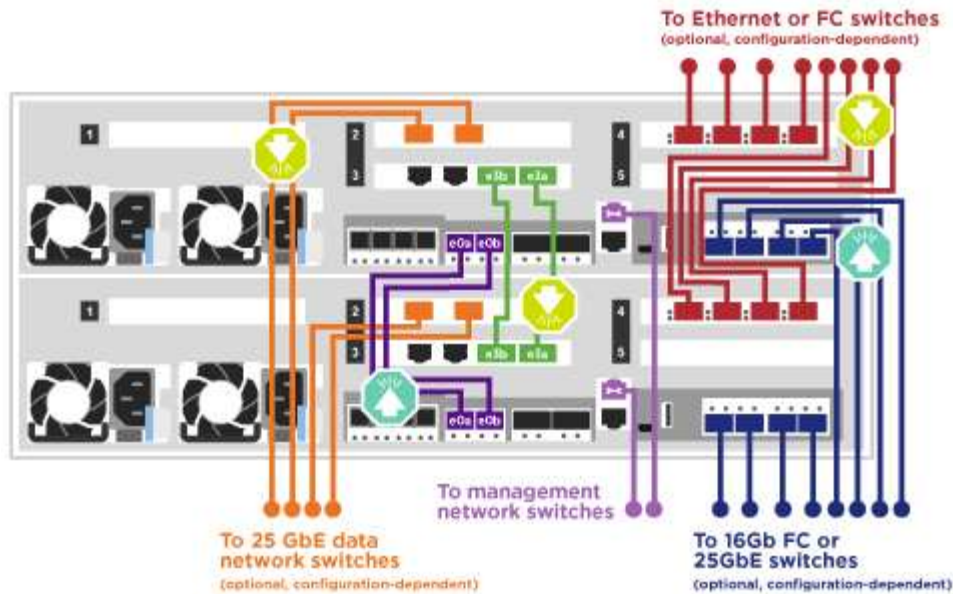

2. Go to [Step 4: Cable controllers to drive shelves](#) for drive shelf cabling instructions.

### Option 2: Cable a switched cluster

The optional data ports, optional NIC cards, mezzanine cards, and management ports on the controller modules are connected to switches. The cluster interconnect and HA ports are cabled on to the cluster/HA switch.

You must have contacted your network administrator for information about connecting the system to the switches.

Be sure to check the direction of the cable pull-tabs when inserting the cables in the ports. Cable pull-tabs are up for all onboard ports and down for expansion (NIC) cards.

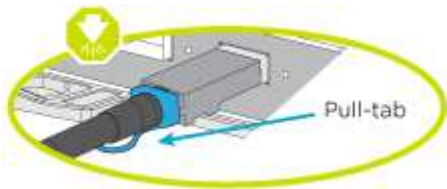
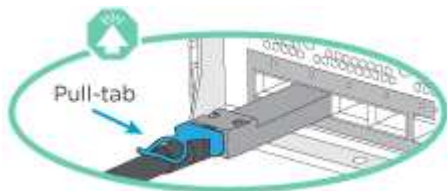

As you insert the connector, you should feel it click into place; if you do not feel it click, remove it, turn it around and try again.

### Steps

1. Use the animation or illustration to complete the cabling between the controllers and to the switches:

[Animation - Switched cluster cabling](#)

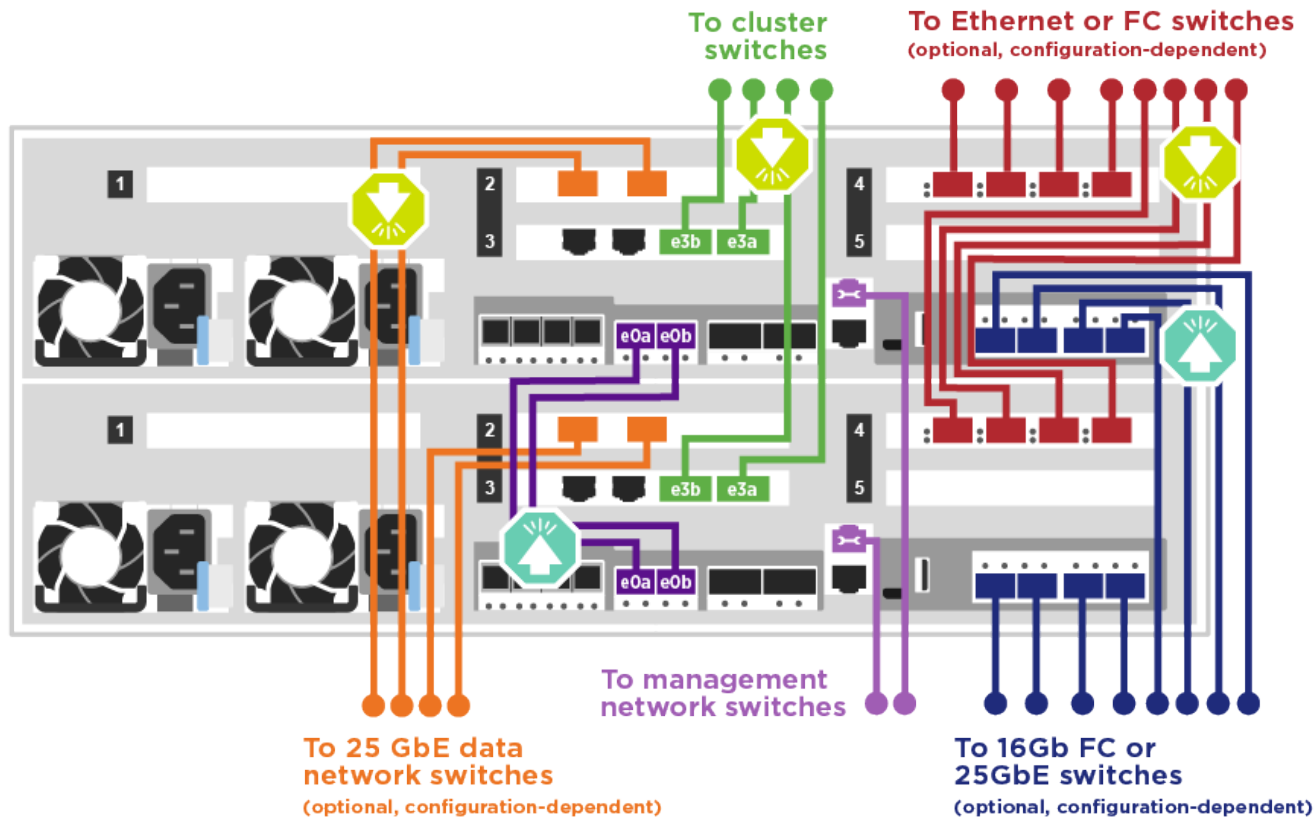

2. Go to [Step 4: Cable controllers to drive shelves](#) for drive shelf cabling instructions.

#### Step 4: Cable controllers to drive shelves

You can cable either NSS224 or SAS shelves to you system.

##### Option 1: Cable the controllers to a single drive shelf

You must cable each controller to the NSM modules on the NS224 drive shelf.

Be sure to check the illustration arrow for the proper cable connector pull-tab orientation. The cable pull-tab for the NS224 are up.

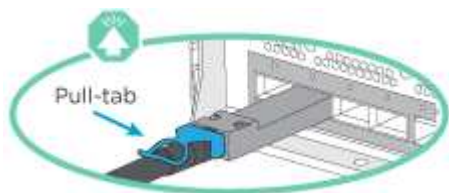

As you insert the connector, you should feel it click into place; if you do not feel it click, remove it, turn it around and try again.

#### Steps

1. Use the following animation or illustration to cable your controllers to a single drive shelf.

[Animation - Cable the controllers to one NS224 drive shelf](#)

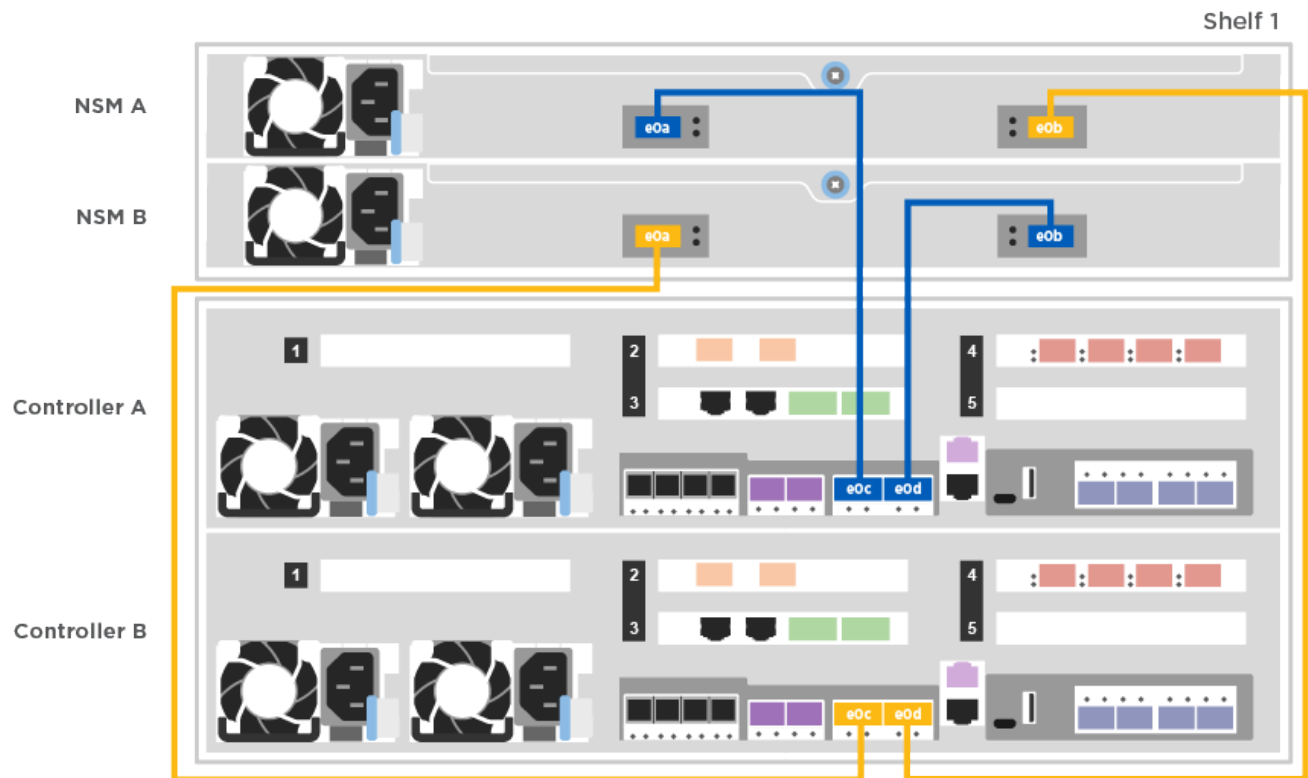

2. Go to [Step 5: Complete system setup and configuration](#) to complete system setup and configuration.

### Option 2: Cable the controllers to two drive shelves

You must cable each controller to the NSM modules on both NS224 drive shelves.

Be sure to check the illustration arrow for the proper cable connector pull-tab orientation. The cable pull-tab for the NS224 are up.

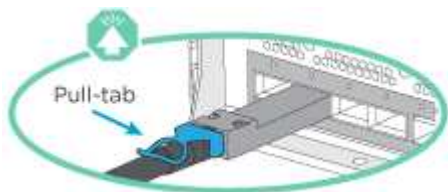

As you insert the connector, you should feel it click into place; if you do not feel it click, remove it, turn it around and try again.

### Steps

1. Use the following animation or illustration to cable your controllers to two drive shelves.

[Animation - Cable the controllers to one NS224 drive shelf](#)

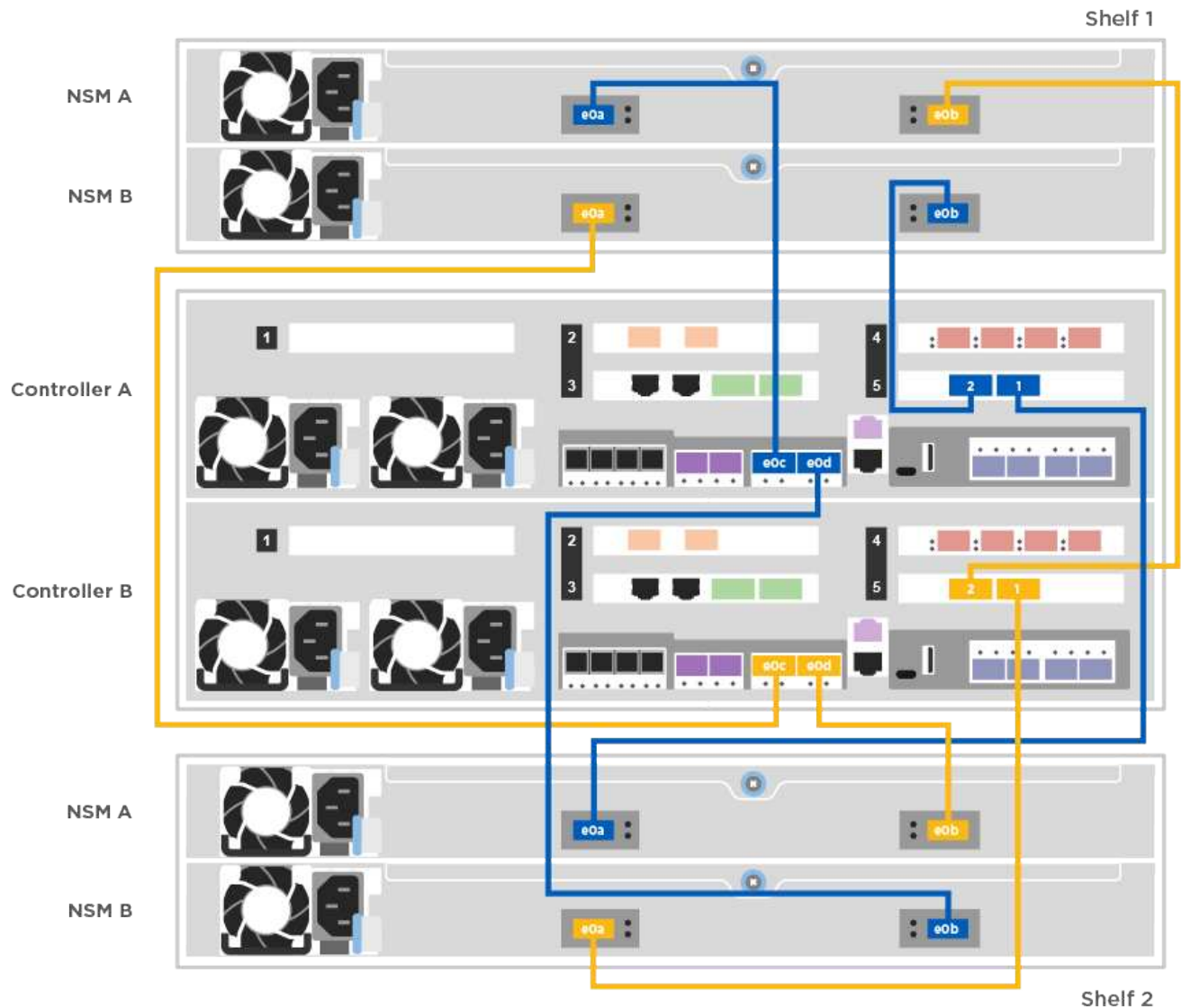

2. Go to [Step 5: Complete system setup and configuration](#) to complete system setup and configuration.

### Option 3: Cable the controllers to SAS drive shelves

You must cable each controller to the IOM modules on both SAS drive shelves.

Be sure to check the illustration arrow for the proper cable connector pull-tab orientation. The cable pull-tab for the DS224-C are down.

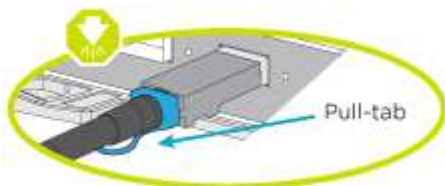

As you insert the connector, you should feel it click into place; if you do not feel it click, remove it, turn it around and try again.

### Steps

1. Use the following illustration to cable your controllers to two drive shelves.

[Animation - Cable the controllers to SAS drive shelves](#)

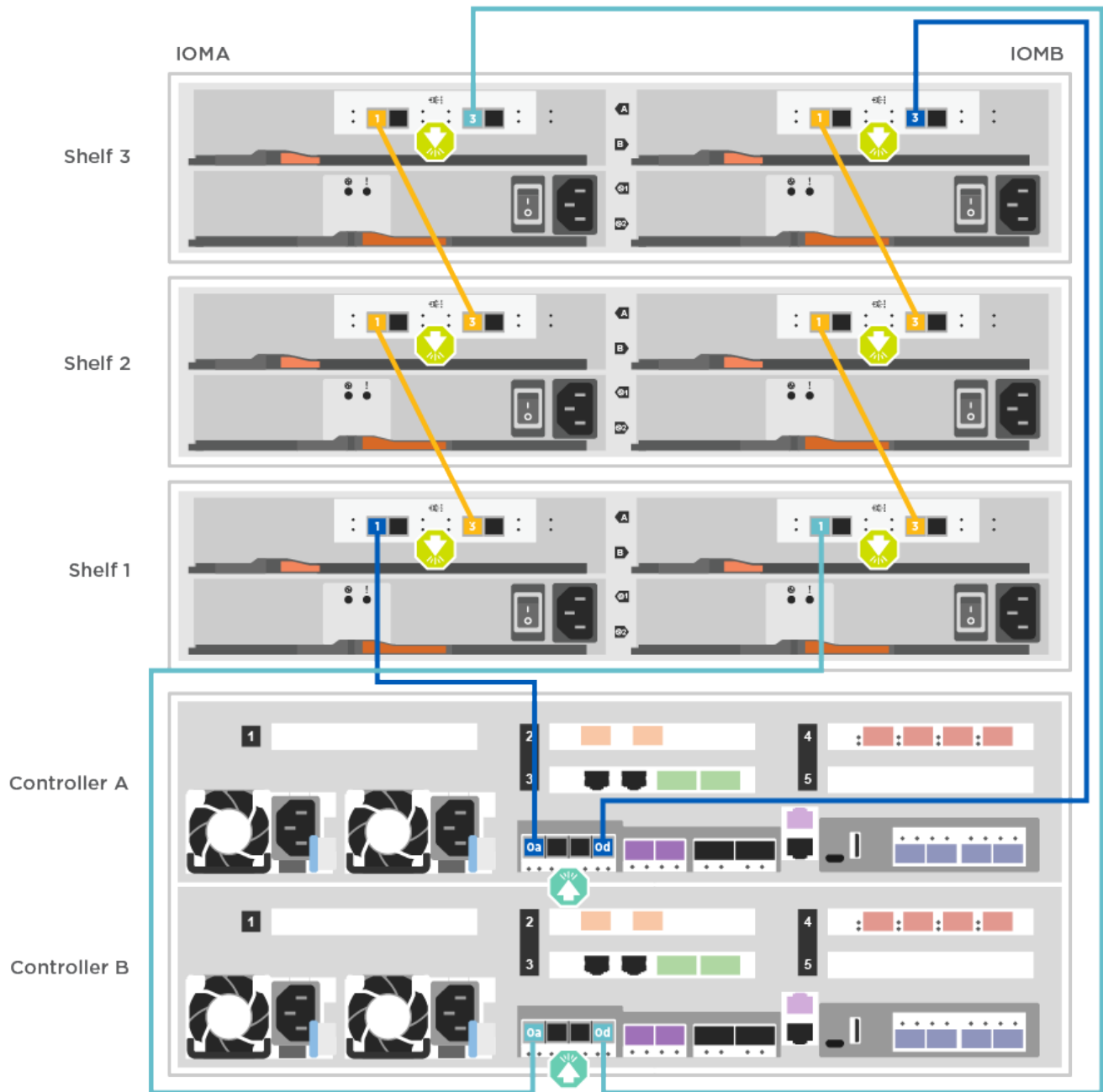

2. Go to [Step 5: Complete system setup and configuration](#) to complete system setup and configuration.

### Step 5: Complete system setup and configuration

You can complete the system setup and configuration using cluster discovery with only a connection to the switch and laptop, or by connecting directly to a controller in the system and then connecting to the management switch.

#### Option 1: Completing system setup and configuration if network discovery is enabled

If you have network discovery enabled on your laptop, you can complete system setup and configuration using



automatic cluster discovery.

1. Use the following animation to set one or more drive shelf IDs:

If your system has NS224 drive shelves, the shelves are pre-set to shelf ID 00 and 01. If you want to change the shelf IDs, you must create a tool to insert into the hole where button is located.

[Animation - Set drive shelf IDs](#)

2. Plug the power cords into the controller power supplies, and then connect them to power sources on different circuits.
3. Make sure that your laptop has network discovery enabled.

See your laptop's online help for more information.

4. Use the following animation to connect your laptop to the Management switch.

[Animation - Connect your laptop to the Management switch](#)

5. Select an ONTAP icon listed to discover:

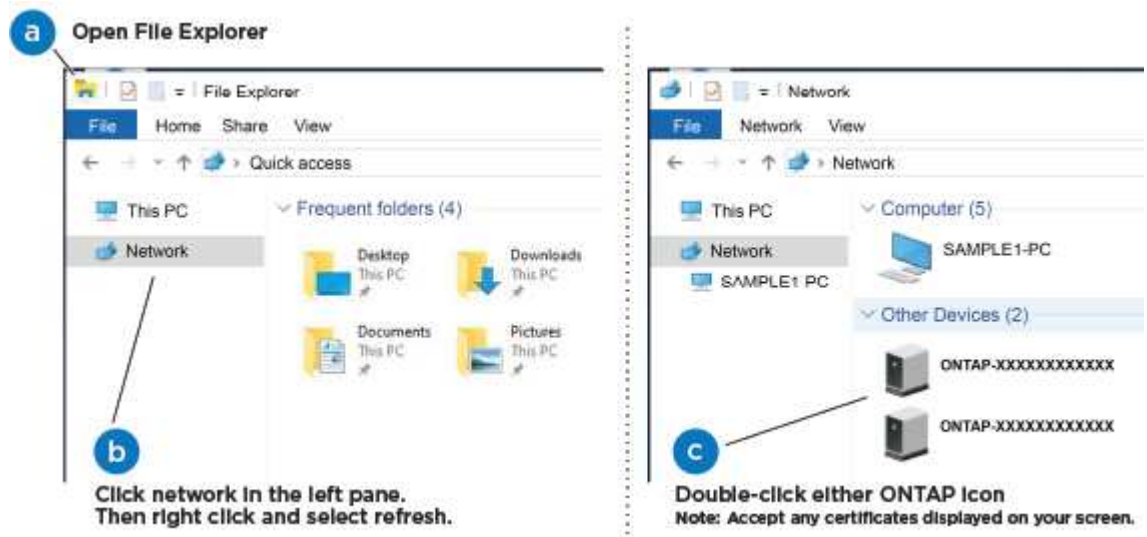

- a. Open File Explorer.
- b. Click network in the left pane.
- c. Right click and select refresh.
- d. Double-click either ONTAP icon and accept any certificates displayed on your screen.

 XXXXX is the system serial number for the target node.

System Manager opens.

6. Use System Manager guided setup to configure your system using the data you collected in the *NetApp ONTAP Configuration Guide*.

[ONTAP Configuration Guide](#)

7. Set up your account and download Active IQ Config Advisor:

- a. Log in to your existing account or create an account.

[NetApp Support Registration](#)

- b. Register your system.

[NetApp Product Registration](#)

- c. Download Active IQ Config Advisor.

[NetApp Downloads: Config Advisor](#)

8. Verify the health of your system by running Config Advisor.

9. After you have completed the initial configuration, go to the [ONTAP & ONTAP System Manager Documentation Resources](#) page for information about configuring additional features in ONTAP.

## Option 2: Completing system setup and configuration if network discovery is not enabled

If network discovery is not enabled on your laptop, you must complete the configuration and setup using this task.

1. Cable and configure your laptop or console:

- a. Set the console port on the laptop or console to 115,200 baud with N-8-1.



See your laptop or console's online help for how to configure the console port.

- b. Connect the console cable to the laptop or console using the console cable that came with your system, and then connect the laptop to the management switch on the management subnet .

- c. Assign a TCP/IP address to the laptop or console, using one that is on the management subnet.

2. Use the following animation to set one or more drive shelf IDs:

[Animation - Set drive shelf IDs](#)

If your system has NS224 drive shelves, the shelves are pre-set to shelf ID 00 and 01. If you want to change the shelf IDs, you must create a tool to insert into the hole where button is located.

[Animation - Set drive shelf IDs](#)

3. Plug the power cords into the controller power supplies, and then connect them to power sources on different circuits.



FAS8300 and FAS8700 shown.

[Animation - Power on the controllers](#)



Initial booting may take up to eight minutes.

4. Assign an initial node management IP address to one of the nodes.

If the management network has DHCP...	Then...
Configured	Record the IP address assigned to the new controllers.
Not configured	<p>a. Open a console session using PuTTY, a terminal server, or the equivalent for your environment.</p> <div style="display: flex; align-items: center; margin: 10px 0;">  <p>Check your laptop or console's online help if you do not know how to configure PuTTY.</p> </div> <p>b. Enter the management IP address when prompted by the script.</p>

5. Using System Manager on your laptop or console, configure your cluster:

- a. Point your browser to the node management IP address.



The format for the address is https://x.x.x.x.

- b. Configure the system using the data you collected in the *NetApp ONTAP Configuration guide*.

[ONTAP Configuration Guide](#)

6. Set up your account and download Active IQ Config Advisor:

- a. Log in to your existing account or create an account.

[NetApp Support Registration](#)

- b. Register your system.

[NetApp Product Registration](#)

- c. Download Active IQ Config Advisor.

[NetApp Downloads: Config Advisor](#)

7. Verify the health of your system by running Config Advisor.

8. After you have completed the initial configuration, go to the [ONTAP & ONTAP System Manager Documentation Resources](#) page for information about configuring additional features in ONTAP.

## Maintain

### Maintain ASA A400 hardware

For the ASA A400 storage system, you can perform maintenance procedures on the following components.

### Boot media

The boot media stores a primary and secondary set of boot image files that the system uses when it boots.

## Chassis

The chassis is the physical enclosure housing all the controller components such as the controller/CPU unit, power supply, and I/O.

## Controller

A controller consists of a board, firmware, and software. It controls the drives and implements the ONTAP functions.

## DIMM

You must replace a DIMM (dual in-line memory module) when a memory mismatch is present, or you have a failed DIMM.

## Fan

The fan cools the controller.

## NVDIMM battery

A NVDIMM battery is responsible for maintaining power to the NVDIMM module.

## NVDIMM

The NVDIMM (non-volatile dual in-line memory module) manages the data transfer from the volatile memory to the non-volatile storage, and maintains data integrity in the event of a power loss or system shutdown.

## PCIe or Mezzanine card

A PCIe (peripheral component interconnect express) card is an expansion card that plugs into the PCIe slot on the motherboard.

A Mezzanine card is an expansion card that is designed to be inserted into a specialized slot on the motherboard.

## Power supply

A power supply provides a redundant power source in a controller shelf.

## Real time clock battery

A real time clock battery preserves system date and time information if the power is off.

## Boot media

### Overview of boot media replacement - ASA A400

The boot media stores a primary and secondary set of system (boot image) files that the system uses when it boots. Depending on your network configuration, you can perform either a nondisruptive or disruptive replacement.

You must have a USB flash drive, formatted to FAT32, with the appropriate amount of storage to hold the `image_XXX.tgz` file.

You also must copy the `image_XXX.tgz` file to the USB flash drive for later use in this procedure.

- The nondisruptive and disruptive methods for replacing a boot media both require you to restore the `var` file system:
  - For nondisruptive replacement, the HA pair must be connected to a network to restore the `var` file system.
  - For disruptive replacement, you do not need a network connection to restore the `var` file system, but the process requires two reboots.
- You must replace the failed component with a replacement FRU component you received from your provider.
- It is important that you apply the commands in these steps on the correct node:
  - The *impaired* node is the node on which you are performing maintenance.
  - The *healthy node* is the HA partner of the impaired node.

### Check onboard encryption - ASA A400

Prior to shutting down the impaired controller and checking the status of the onboard encryption keys, you must check the status of the impaired controller, disable automatic giveback, and check which version of ONTAP is running on the system.

If you have a cluster with more than two nodes, it must be in quorum. If the cluster is not in quorum or a healthy controller shows false for eligibility and health, you must correct the issue before shutting down the impaired controller; see the [Synchronize a node with the cluster](#).

### Steps

1. Check the status of the impaired controller:
  - If the impaired controller is at the login prompt, log in as `admin`.
  - If the impaired controller is at the `LOADER` prompt and is part of HA configuration, log in as `admin` on the healthy controller.
  - If the impaired controller is in a standalone configuration and at `LOADER` prompt, contact [mysupport.netapp.com](http://mysupport.netapp.com).
2. If AutoSupport is enabled, suppress automatic case creation by invoking an AutoSupport message:

```
system node autosupport invoke -node * -type all -message  
MAINT=number_of_hours_downh
```

The following AutoSupport message suppresses automatic case creation for two hours: `cluster1:*>`

```
system node autosupport invoke -node * -type all -message MAINT=2h
```
3. Check the version of ONTAP the system is running on the impaired controller if up, or on the partner controller if the impaired controller is down, using the `version -v` command:
  - If `<Ino-DARE>` or `<1Ono-DARE>` is displayed in the command output, the system does not support NVE, proceed to shut down the controller.
  - If `<Ino-DARE>` is not displayed in the command output, and the system is running ONTAP 9.6 or later, go to the next section.

4. If the impaired controller is part of an HA configuration, disable automatic giveback from the healthy controller: `storage failover modify -node local -auto-giveback false` or `storage failover modify -node local -auto-giveback-after-panic false`

### Check NVE or NSE on systems running ONTAP 9.6 and later

Before shutting down the impaired controller, you need to verify whether the system has either NetApp Volume Encryption (NVE) or NetApp Storage Encryption (NSE) enabled. If so, you need to verify the configuration.

1. Verify whether NVE is in use for any volumes in the cluster: `volume show -is-encrypted true`

If any volumes are listed in the output, NVE is configured and you need to verify the NVE configuration. If no volumes are listed, check whether NSE is configured and in use.

2. Verify whether NSE is configured and in use: `storage encryption disk show`
  - If the command output lists the drive details with Mode & Key ID information, NSE is configured and you need to verify the NSE configuration and in use.
  - If no disks are shown, NSE is not configured.
  - If NVE and NSE are not configured, no drives are protected with NSE keys, it's safe to shut down the impaired controller.

### Verify NVE configuration

1. Display the key IDs of the authentication keys that are stored on the key management servers: `security key-manager key query`



After the ONTAP 9.6 release, you may have additional key manager types. The types are KMIP, AKV, and GCP. The process for confirming these types is the same as confirming external or onboard key manager types.

- If the Key Manager type displays `external` and the Restored column displays `yes`, it's safe to shut down the impaired controller.
  - If the Key Manager type displays `onboard` and the Restored column displays `yes`, you need to complete some additional steps.
  - If the Key Manager type displays `external` and the Restored column displays anything other than `yes`, you need to complete some additional steps.
  - If the Key Manager type displays `onboard` and the Restored column displays anything other than `yes`, you need to complete some additional steps.
2. If the Key Manager type displays `onboard` and the Restored column displays `yes`, manually back up the OKM information:
    - a. Go to advanced privilege mode and enter `y` when prompted to continue: `set -priv advanced`
    - b. Enter the command to display the key management information: `security key-manager onboard show-backup`
    - c. Copy the contents of the backup information to a separate file or your log file. You'll need it in disaster scenarios where you might need to manually recover OKM.
    - d. Return to admin mode: `set -priv admin`

- e. Shut down the impaired controller.
3. If the `Key Manager` type displays `external` and the `Restored` column displays anything other than `yes`:
    - a. Restore the external key management authentication keys to all nodes in the cluster: `security key-manager external restore`

If the command fails, contact NetApp Support.

[mysupport.netapp.com](https://mysupport.netapp.com)

    - b. Verify that the `Restored` column equals `yes` for all authentication keys: `security key-manager key query`
    - c. Shut down the impaired controller.
  4. If the `Key Manager` type displays `onboard` and the `Restored` column displays anything other than `yes`:
    - a. Enter the onboard security key-manager sync command: `security key-manager onboard sync`



Enter the customer's 32 character, alphanumeric onboard key management passphrase at the prompt. If the passphrase cannot be provided, contact NetApp Support.

[mysupport.netapp.com](https://mysupport.netapp.com)

- b. Verify the `Restored` column shows `yes` for all authentication keys: `security key-manager key query`
- c. Verify that the `Key Manager` type shows `onboard`, and then manually back up the OKM information.
- d. Go to advanced privilege mode and enter `y` when prompted to continue: `set -priv advanced`
- e. Enter the command to display the key management backup information: `security key-manager onboard show-backup`
- f. Copy the contents of the backup information to a separate file or your log file. You'll need it in disaster scenarios where you might need to manually recover OKM.
- g. Return to admin mode: `set -priv admin`
- h. You can safely shut down the controller.

## Verify NSE configuration

1. Display the key IDs of the authentication keys that are stored on the key management servers: `security key-manager key query -key-type NSE-AK`



After the ONTAP 9.6 release, you may have additional key manager types. The types are `KMIP`, `AKV`, and `GCP`. The process for confirming these types is the same as confirming `external` or `onboard` key manager types.

- If the `Key Manager` type displays `external` and the `Restored` column displays `yes`, it's safe to shut down the impaired controller.
- If the `Key Manager` type displays `onboard` and the `Restored` column displays `yes`, you need to complete some additional steps.
- If the `Key Manager` type displays `external` and the `Restored` column displays anything other than

yes, you need to complete some additional steps.

- If the Key Manager type displays `external` and the Restored column displays anything other than `yes`, you need to complete some additional steps.

2. If the Key Manager type displays `onboard` and the Restored column displays `yes`, manually back up the OKM information:
  - a. Go to advanced privilege mode and enter `y` when prompted to continue: `set -priv advanced`
  - b. Enter the command to display the key management information: `security key-manager onboard show-backup`
  - c. Copy the contents of the backup information to a separate file or your log file. You'll need it in disaster scenarios where you might need to manually recover OKM.
  - d. Return to admin mode: `set -priv admin`
  - e. You can safely shut down the controller.
3. If the Key Manager type displays `external` and the Restored column displays anything other than `yes`:
  - a. Restore the external key management authentication keys to all nodes in the cluster: `security key-manager external restore`  
  
If the command fails, contact NetApp Support.  
  
[mysupport.netapp.com](https://mysupport.netapp.com)
  - b. Verify that the Restored column equals `yes` for all authentication keys: `security key-manager key query`
  - c. You can safely shut down the controller.
4. If the Key Manager type displays `onboard` and the Restored column displays anything other than `yes`:
  - a. Enter the onboard security key-manager sync command: `security key-manager onboard sync`  
  
Enter the customer's 32 character, alphanumeric onboard key management passphrase at the prompt. If the passphrase cannot be provided, contact NetApp Support.  
  
[mysupport.netapp.com](https://mysupport.netapp.com)
  - b. Verify the Restored column shows `yes` for all authentication keys: `security key-manager key query`
  - c. Verify that the Key Manager type shows `onboard`, and then manually back up the OKM information.
  - d. Go to advanced privilege mode and enter `y` when prompted to continue: `set -priv advanced`
  - e. Enter the command to display the key management backup information: `security key-manager onboard show-backup`
  - f. Copy the contents of the backup information to a separate file or your log file. You'll need it in disaster scenarios where you might need to manually recover OKM.
  - g. Return to admin mode: `set -priv admin`
  - h. You can safely shut down the controller.



## Shut down the impaired controller - ASA A400

After completing the NVE or NSE tasks, you need to complete the shutdown of the impaired controller. Shut down or take over the impaired controller using the appropriate procedure for your configuration.

### Option 1: Most configurations

After completing the NVE or NSE tasks, you need to complete the shutdown of the impaired controller.

#### Steps

- a. Take the impaired controller to the LOADER prompt:

If the impaired controller displays...	Then...
The LOADER prompt	Go to Remove controller module.
Waiting for giveback...	Press Ctrl-C, and then respond <code>y</code> when prompted.
System prompt or password prompt (enter system password)	Take over or halt the impaired controller from the healthy controller: <code>storage failover takeover -ofnode impaired_node_name</code>  When the impaired controller shows Waiting for giveback..., press Ctrl-C, and then respond <code>y</code> .

- b. From the LOADER prompt, enter: `printenv` to capture all boot environmental variables. Save the output to your log file.



This command may not work if the boot device is corrupted or non-functional.

### Option 2: Controller is in a MetroCluster configuration



Do not use this procedure if your system is in a two-node MetroCluster configuration.

To shut down the impaired controller, you must determine the status of the controller and, if necessary, take over the controller so that the healthy controller continues to serve data from the impaired controller storage.

- If you have a cluster with more than two nodes, it must be in quorum. If the cluster is not in quorum or a healthy controller shows false for eligibility and health, you must correct the issue before shutting down the impaired controller; see [Synchronize a node with the cluster](#).
- If you have a MetroCluster configuration, you must have confirmed that the MetroCluster Configuration State is configured and that the nodes are in an enabled and normal state (`metrocluster node show`).

#### Steps

1. If AutoSupport is enabled, suppress automatic case creation by invoking an AutoSupport message:  
`system node autosupport invoke -node * -type all -message  
MAINT=number_of_hours_downh`

The following AutoSupport message suppresses automatic case creation for two hours: `cluster1:*> system node autosupport invoke -node * -type all -message MAINT=2h`

2. Disable automatic giveback from the console of the healthy controller: `storage failover modify -node local -auto-giveback false`
3. Take the impaired controller to the LOADER prompt:

If the impaired controller is displaying...	Then...
The LOADER prompt	Go to the next step.
Waiting for giveback...	Press Ctrl-C, and then respond <code>y</code> when prompted.
System prompt or password prompt (enter system password)	Take over or halt the impaired controller from the healthy controller: <code>storage failover takeover -ofnode <i>impaired_node_name</i></code>  When the impaired controller shows Waiting for giveback..., press Ctrl-C, and then respond <code>y</code> .

### Option 3: Controller is in a two-node Metrocluster

To shut down the impaired controller, you must determine the status of the controller and, if necessary, switch over the controller so that the healthy controller continues to serve data from the impaired controller storage.

#### About this task

- You must leave the power supplies turned on at the end of this procedure to provide power to the healthy controller.

#### Steps

1. Check the MetroCluster status to determine whether the impaired controller has automatically switched over to the healthy controller: `metrocluster show`
2. Depending on whether an automatic switchover has occurred, proceed according to the following table:

If the impaired controller...	Then...
Has automatically switched over	Proceed to the next step.
Has not automatically switched over	Perform a planned switchover operation from the healthy controller: <code>metrocluster switchover</code>
Has not automatically switched over, you attempted switchover with the <code>metrocluster switchover</code> command, and the switchover was vetoed	Review the veto messages and, if possible, resolve the issue and try again. If you are unable to resolve the issue, contact technical support.

3. Resynchronize the data aggregates by running the `metrocluster heal -phase aggregates` command from the surviving cluster.

```
controller_A_1::> metrocluster heal -phase aggregates
[Job 130] Job succeeded: Heal Aggregates is successful.
```

If the healing is vetoed, you have the option of reissuing the `metrocluster heal` command with the `-override-vetoes` parameter. If you use this optional parameter, the system overrides any soft vetoes that prevent the healing operation.

4. Verify that the operation has been completed by using the `metrocluster operation show` command.

```
controller_A_1::> metrocluster operation show
Operation: heal-aggregates
State: successful
Start Time: 7/25/2016 18:45:55
End Time: 7/25/2016 18:45:56
Errors: -
```

5. Check the state of the aggregates by using the `storage aggregate show` command.

```
controller_A_1::> storage aggregate show
Aggregate      Size Available Used% State   #Vols  Nodes           RAID
Status
-----
...
aggr_b2       227.1GB   227.1GB   0% online    0 mcc1-a2
raid_dp, mirrored, normal...
```

6. Heal the root aggregates by using the `metrocluster heal -phase root-aggregates` command.

```
mcc1A::> metrocluster heal -phase root-aggregates
[Job 137] Job succeeded: Heal Root Aggregates is successful
```

If the healing is vetoed, you have the option of reissuing the `metrocluster heal` command with the `-override-vetoes` parameter. If you use this optional parameter, the system overrides any soft vetoes that prevent the healing operation.

7. Verify that the heal operation is complete by using the `metrocluster operation show` command on the destination cluster:

```
mccl1A::> metrocluster operation show
Operation: heal-root-aggregates
State: successful
Start Time: 7/29/2016 20:54:41
End Time: 7/29/2016 20:54:42
Errors: -
```

8. On the impaired controller module, disconnect the power supplies.

### Replace the boot media - ASA A400

To replace the boot media, you must remove the impaired controller module, install the replacement boot media, and transfer the boot image to a USB flash drive.

#### Step 1: Remove the controller module

To access components inside the controller module, you must remove the controller module from the chassis.

##### Steps

1. If you are not already grounded, properly ground yourself.
2. Release the power cable retainers, and then unplug the cables from the power supplies.
3. Loosen the hook and loop strap binding the cables to the cable management device, and then unplug the system cables and SFPs (if needed) from the controller module, keeping track of where the cables were connected.

Leave the cables in the cable management device so that when you reinstall the cable management device, the cables are organized.

4. Remove the cable management device from the controller module and set it aside.
5. Press down on both of the locking latches, and then rotate both latches downward at the same time.

The controller module moves slightly out of the chassis.

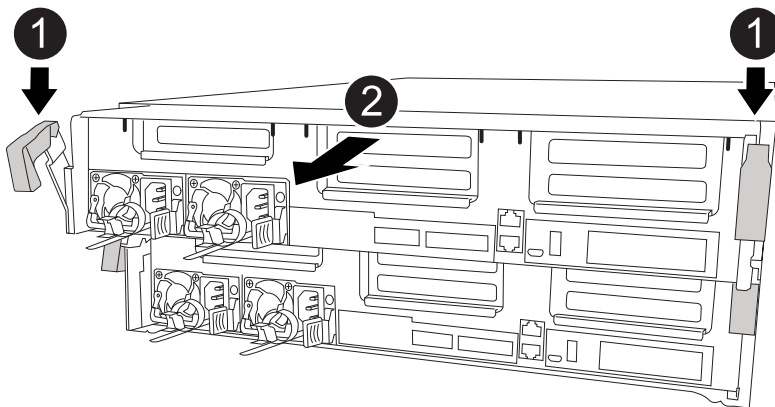

**1** Locking latches

<b>2</b>	Controller moves slightly out of chassis
----------	--

6. Slide the controller module out of the chassis.

Make sure that you support the bottom of the controller module as you slide it out of the chassis.

7. Place the controller module on a stable, flat surface.

## Step 2: Replace the boot media

You must locate the boot media in the controller module (see the FRU map on the controller module), and then follow the directions to replace it.

### Before you begin

Although the contents of the boot media is encrypted, it is a best practice to erase the contents of the boot media before replacing it. For more information, see the [Statement of Volatility](#) for your system on the NetApp Support Site.



You must log into the NetApp Support Site to display the *Statement of Volatility* for your system.

You can use the following animation, illustration, or the written steps to replace the boot media.

### Animation - Replace the boot media

#### Steps

1. Open the air duct:

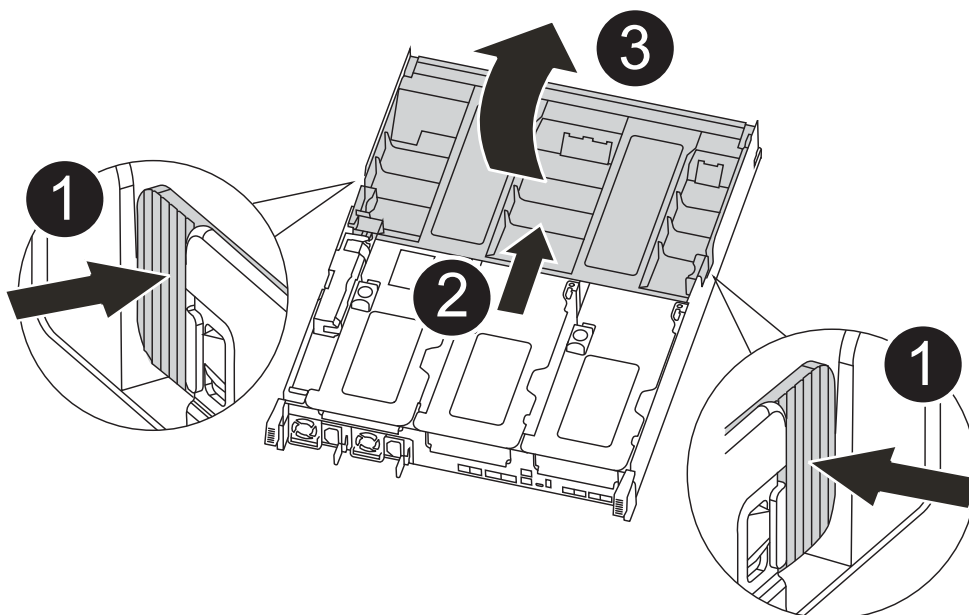

<b>1</b>	Locking tabs
----------	--------------

<b>2</b>	Slide air duct toward back of controller
<b>3</b>	Rotate air duct up

- a. Press the locking tabs on the sides of the air duct in toward the middle of the controller module.
- b. Slide the air duct toward the back of the controller module, and then rotate it upward to its completely open position.

2. Locate and remove the boot media from the controller module:

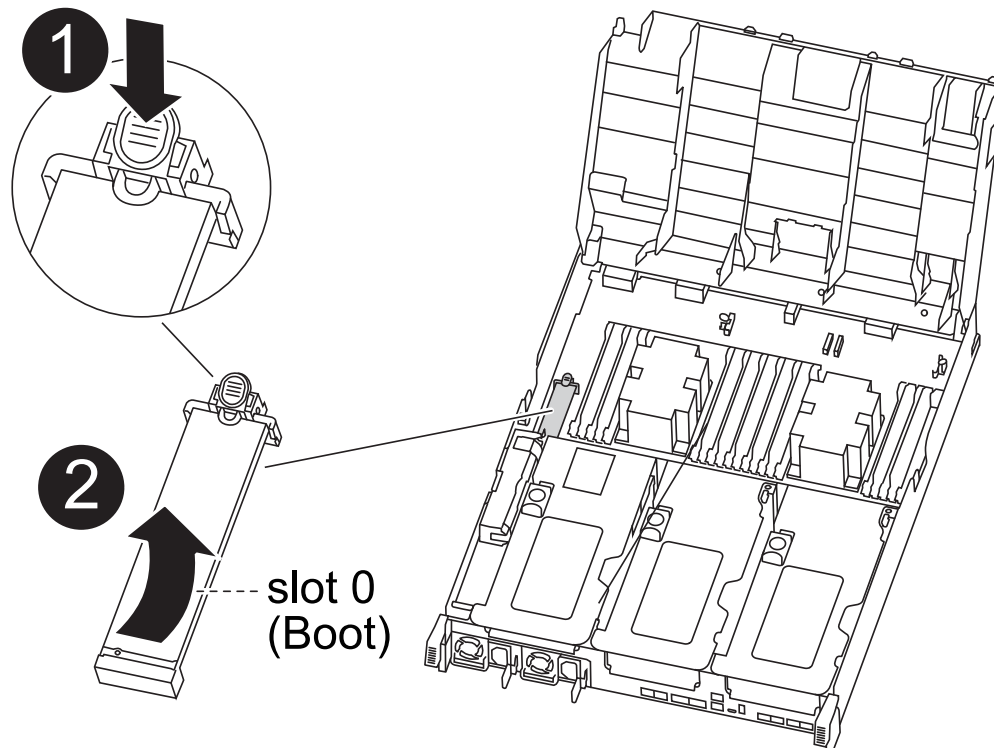

<b>1</b>	Press blue button
<b>2</b>	Rotate boot media up and remove from socket

- a. Press the blue button at the end of the boot media until the lip on the boot media clears the blue button.
  - b. Rotate the boot media up and gently pull the boot media out of the socket.
3. Align the edges of the replacement boot media with the boot media socket, and then gently push it into the socket.
  4. Check the boot media to make sure that it is seated squarely and completely in the socket.

If necessary, remove the boot media and reseal it into the socket.

5. Lock the boot media in place:
  - a. Rotate the boot media down toward the motherboard.

- b. Placing a finger at the end of the boot media by the blue button, push down on the boot media end to engage the blue locking button.
  - c. While pushing down on the boot media, lift the blue locking button to lock the boot media in place.
6. Close the air duct.

### Step 3: Transfer the boot image to the boot media

The replacement boot media that you installed does not have a boot image, so you need to transfer a boot image using a USB flash drive.

#### Before you begin

- You must have a USB flash drive, formatted to MBR/FAT32, with at least 4GB capacity
- A copy of the same image version of ONTAP as what the impaired controller was running. You can download the appropriate image from the Downloads section on the NetApp Support Site
  - If NVE is enabled, download the image with NetApp Volume Encryption, as indicated in the download button.
  - If NVE is not enabled, download the image without NetApp Volume Encryption, as indicated in the download button.
- If your system is an HA pair, you must have a network connection.
- If your system is a stand-alone system you do not need a network connection, but you must perform an additional reboot when restoring the `var` file system.

#### Steps

1. Download and copy the appropriate service image from the NetApp Support Site to the USB flash drive.
  - a. Download the service image to your work space on your laptop.
  - b. Unzip the service image.



If you are extracting the contents using Windows, do not use WinZip to extract the netboot image. Use another extraction tool, such as 7-Zip or WinRAR.

There are two folders in the unzipped service image file:

- `boot`
- `efi`

- c. Copy the `efi` folder to the top directory on the USB flash drive.

The USB flash drive should have the `efi` folder and the same Service Image (BIOS) version of what the impaired controller is running.

- d. Remove the USB flash drive from your laptop.
2. If you have not already done so, close the air duct.
3. Align the end of the controller module with the opening in the chassis, and then gently push the controller module halfway into the system.
4. Reinstall the cable management device and recable the system, as needed.

When recabling, remember to reinstall the media converters (SFPs or QSFPs) if they were removed.

5. Plug the power cable into the power supply and reinstall the power cable retainer.
6. Insert the USB flash drive into the USB slot on the controller module.

Make sure that you install the USB flash drive in the slot labeled for USB devices, and not in the USB console port.

7. Complete the installation of the controller module:
  - a. Plug the power cord into the power supply, reinstall the power cable locking collar, and then connect the power supply to the power source.
  - b. Firmly push the controller module into the chassis until it meets the midplane and is fully seated.

The locking latches rise when the controller module is fully seated.



Do not use excessive force when sliding the controller module into the chassis to avoid damaging the connectors.

The controller module begins to boot as soon as it is fully seated in the chassis. Be prepared to interrupt the boot process.

- c. Rotate the locking latches upward, tilting them so that they clear the locking pins, and then lower them into the locked position.
  - d. If you have not already done so, reinstall the cable management device.
8. Interrupt the boot process by pressing Ctrl-C to stop at the LOADER prompt.

If you miss this message, press Ctrl-C, select the option to boot to Maintenance mode, and then `halt` the controller to boot to LOADER.

9. If the controller is in a stretch or fabric-attached MetroCluster, you must restore the FC adapter configuration:
  - a. Boot to Maintenance mode: `boot_ontap maint`
  - b. Set the MetroCluster ports as initiators: `ucadmin modify -m fc -t initiator adapter_name`
  - c. Halt to return to Maintenance mode: `halt`

The changes will be implemented when the system is booted.

## Boot the recovery image - ASA A400

The procedure for booting the impaired controller from the recovery image depends on whether the system is in a two-node MetroCluster configuration.

### Option 1: Most systems

You must boot the ONTAP image from the USB drive, restore the file system, and verify the environmental variables.

This procedure applies to systems that are not in a two-node MetroCluster configuration.

### Steps

1. From the LOADER prompt, boot the recovery image from the USB flash drive: `boot_recovery`



The image is downloaded from the USB flash drive.

2. When prompted, either enter the name of the image or accept the default image displayed inside the brackets on your screen.
3. Restore the `var` file system:

If your system has...	Then...
A network connection	<ol style="list-style-type: none"> <li>a. Press <code>y</code> when prompted to restore the backup configuration.</li> <li>b. Set the healthy controller to advanced privilege level: <code>set -privilege advanced</code></li> <li>c. Run the restore backup command: <code>system node restore-backup -node local -target-address <i>impaired_node_IP_address</i></code></li> <li>d. Return the controller to admin level: <code>set -privilege admin</code></li> <li>e. Press <code>y</code> when prompted to use the restored configuration.</li> <li>f. Press <code>y</code> when prompted to reboot the controller.</li> </ol>
No network connection	<ol style="list-style-type: none"> <li>a. Press <code>n</code> when prompted to restore the backup configuration.</li> <li>b. Reboot the system when prompted by the system.</li> <li>c. Select the <b>Update flash from backup config</b> (sync flash) option from the displayed menu.</li> </ol> <p>If you are prompted to continue with the update, press <code>y</code>.</p>

4. Ensure that the environmental variables are set as expected:
  - a. Take the controller to the LOADER prompt.
  - b. Check the environment variable settings with the `printenv` command.
  - c. If an environment variable is not set as expected, modify it with the `setenv environment-variable-name changed-value` command.
  - d. Save your changes using the `savenv` command.
5. The next depends on your system configuration:
  - If your system has onboard keymanager, NSE or NVE configured, go to [Restore OKM, NSE, and NVE as needed](#)
  - If your system does not have onboard keymanager, NSE or NVE configured, complete the steps in this section.
6. From the LOADER prompt, enter the `boot_ontap` command.

*If you see...	Then...*
The login prompt	Go to the next Step.

*If you see...	Then...*
Waiting for giveback...	<ol style="list-style-type: none"> <li>a. Log into the partner controller.</li> <li>b. Confirm the target controller is ready for giveback with the <code>storage failover show</code> command.</li> </ol>

7. Connect the console cable to the partner controller.
8. Give back the controller using the `storage failover giveback -fromnode local` command.
9. At the cluster prompt, check the logical interfaces with the `net int -is-home false` command.

If any interfaces are listed as "false", revert those interfaces back to their home port using the `net int revert` command.

10. Move the console cable to the repaired controller and run the `version -v` command to check the ONTAP versions.
11. Restore automatic giveback if you disabled it by using the `storage failover modify -node local -auto-giveback true` command.

## Option 2: Controller is in a two-node MetroCluster

You must boot the ONTAP image from the USB drive and verify the environmental variables.

This procedure applies to systems in a two-node MetroCluster configuration.

### Steps

1. From the LOADER prompt, boot the recovery image from the USB flash drive: `boot_recovery`

The image is downloaded from the USB flash drive.

2. When prompted, either enter the name of the image or accept the default image displayed inside the brackets on your screen.
3. After the image is installed, start the restoration process:
  - a. Press `n` when prompted to restore the backup configuration.
  - b. Press `y` when prompted to reboot to start using the newly installed software.

You should be prepared to interrupt the boot process when prompted.

4. As the system boots, press `Ctrl-C` after you see the `Press Ctrl-C for Boot Menu message.`, and when the Boot Menu is displayed select option 6.
5. Verify that the environmental variables are set as expected.
  - a. Take the node to the LOADER prompt.
  - b. Check the environment variable settings with the `printenv` command.
  - c. If an environment variable is not set as expected, modify it with the `setenv environment-variable-name changed-value` command.
  - d. Save your changes using the `savenv` command.

- e. Reboot the node.

## Switch back aggregates in a two-node MetroCluster configuration - ASA A400

After you have completed the FRU replacement in a two-node MetroCluster configuration, you can perform the MetroCluster switchback operation. This returns the configuration to its normal operating state, with the sync-source storage virtual machines (SVMs) on the formerly impaired site now active and serving data from the local disk pools.

This task only applies to two-node MetroCluster configurations.

### Steps

1. Verify that all nodes are in the enabled state: `metrocluster node show`

```
cluster_B::> metrocluster node show

DR
Group Cluster Node          Configuration  DR
-----
-----
1      cluster_A
      controller_A_1 configured    enabled    heal roots
completed
      cluster_B
      controller_B_1 configured    enabled    waiting for
switchback recovery
2 entries were displayed.
```

2. Verify that resynchronization is complete on all SVMs: `metrocluster vserver show`
3. Verify that any automatic LIF migrations being performed by the healing operations were completed successfully: `metrocluster check lif show`
4. Perform the switchback by using the `metrocluster switchback` command from any node in the surviving cluster.
5. Verify that the switchback operation has completed: `metrocluster show`

The switchback operation is still running when a cluster is in the `waiting-for-switchback` state:

```
cluster_B::> metrocluster show
Cluster          Configuration State      Mode
-----
Local: cluster_B configured    switchover
Remote: cluster_A configured    waiting-for-switchback
```

The switchback operation is complete when the clusters are in the `normal` state.:

```
cluster_B::> metrocluster show
Cluster                Configuration State      Mode
-----
Local: cluster_B configured      normal
Remote: cluster_A configured     normal
```

If a switchback is taking a long time to finish, you can check on the status of in-progress baselines by using the `metrocluster config-replication resync-status show` command.

6. Reestablish any SnapMirror or SnapVault configurations.

### Restore OKM, NSE, and NVE - ASA A400

Once environment variables are checked, you must complete steps specific to systems that have Onboard Key Manager (OKM), NetApp Storage Encryption (NSE) or NetApp Volume Encryption (NVE) enabled.

1. Determine which section you should use to restore your OKM, NSE, or NVE configurations: If NSE or NVE are enabled along with Onboard Key Manager you must restore settings you captured at the beginning of this procedure.
  - If NSE or NVE are enabled and Onboard Key Manager is enabled, go to [Restore NVE or NSE when Onboard Key Manager is enabled](#).
  - If NSE or NVE are enabled for ONTAP 9.6, go to [Restore NSE/NVE on systems running ONTAP 9.6 and later](#).

### Restore NVE or NSE when Onboard Key Manager is enabled

#### Steps

1. Connect the console cable to the target controller.
2. Use the `boot_ontap` command at the LOADER prompt to boot the controller.
3. Check the console output:

If the console displays...	Then...
The LOADER prompt	Boot the controller to the boot menu: <code>boot_ontap menu</code>
Waiting for giveback....	<ol style="list-style-type: none"><li>a. Enter <code>Ctrl-C</code> at the prompt</li><li>b. At the message: Do you wish to halt this node rather than wait [y/n]? , enter: <code>y</code></li><li>c. At the LOADER prompt, enter the <code>boot_ontap menu</code> command.</li></ol>

4. At the Boot Menu, enter the hidden command, `recover_onboard_keymanager` and reply `y` at the prompt

5. Enter the passphrase for the onboard key manager you obtained from the customer at the beginning of this procedure.
6. When prompted to enter the backup data, paste the backup data you captured at the beginning of this procedure, when asked. Paste the output of `security key-manager backup show` OR `security key-manager onboard show-backup` command



The data is output from either `security key-manager backup show` or `security key-manager onboard show-backup` command.

Example of backup data:

```
-----BEGIN BACKUP-----
TmV0QXBwIEtleSBCbG9iAAEAAAAEAAAAcAEAAAAAADuD+byAAAAACEAAAAAAAA
QAAAAAAAAABvOIH0AAAAAMh7qDLRyH1DBz12piVdy9ATSFMT0C0TIYFss4PDjTaV
dzRYkLd1PhQLxAWJwOlyqSr8qY1SEBgm1IWgE5DLRqkiAAAAAAAAACgAAAAAAAA
3WTh7gAAAAAAAAAAAAAAAAIAAAAAAgAZJEIWvdeHr5RCAvHGclo+wAAAAAAAA
lgAAAAAAAAAoAAAAAAAAEOTcR0AAAAAAAAAAAAAAAACAAAAAAJAGr3tJA/
LRzUQRHwv+1aWvAAAAAAAAACQAAAAAAAAAgAAAAAAAAACdhTcvAAAAAJ1PXeBf
ml4NBsSyV1B4jc4A7cvWEFY6ILG6hc6tbKLAHZuvfQ4rlbYAAAAAAAAAAAAAAAA
AAAAAAAAAAAAAAAAAAAAAAAAAAAAAAAAAAAAAAAAAAAAAAAAAAAAAAAAAAAAAA
AAAAAAAAAAAAAAAAAAAAAAAAAAAAAAAAAAAAAAAAAAAAAAAAAAAAAAAAAAAAAA
.
.
.
.
H4nPQM0nrDRYRa9SCv8AAAAAAAAAAAAAAAAAAAAAAAAAAAAAAAAAAAAAAAAAAAA
AAAAAAAAAAAAAAAAAAAAAAAAAAAAAAAAAAAAAAAAAAAAAAAAAAAAAAAAAAAAAA
AAAAAAAA
-----END BACKUP-----
```

7. At the Boot Menu select the option for Normal Boot.  
The system boots to Waiting for giveback... prompt.
8. Confirm the target controller is ready for giveback with the `storage failover show` command.
9. Giveback only the CFO aggregates with the `storage failover giveback -fromnode local -only-cfo-aggregates true` command.
  - If the command fails because of a failed disk, physically disengage the failed disk, but leave the disk in the slot until a replacement is received.
  - If the command fails because of an open CIFS sessions, check with customer how to close out CIFS sessions.



Terminating CIFS can cause loss of data.

- If the command fails because the partner "not ready", wait 5 minutes for the NVMEMs to synchronize.
- If the command fails because of an NDMP, SnapMirror, or SnapVault process, disable the process. See the appropriate Documentation Center for more information.

10. Once the giveback completes, check the failover and giveback status with the `storage failover show` and ``storage failover show-giveback`` commands.

Only the CFO aggregates (root aggregate and CFO style data aggregates) will be shown.

11. Move the console cable to the target controller.
  - a. If you are running ONTAP 9.6 or later, run the security key-manager onboard sync:
  - b. Run the `security key-manager onboard sync` command and then enter the passphrase when prompted.
  - c. Enter the `security key-manager key query` command to see a detailed view of all keys stored in the onboard key manager and verify that the `Restored` column = `yes/true` for all authentication keys.



If the `Restored` column = anything other than `yes/true`, contact Customer Support.

- d. Wait 10 minutes for the key to synchronize across the cluster.
12. Move the console cable to the partner controller.
13. Give back the target controller using the `storage failover giveback -fromnode local` command.
14. Check the giveback status, 3 minutes after it reports complete, using the `storage failover show` command.

If giveback is not complete after 20 minutes, contact Customer Support.

15. At the clustershell prompt, enter the `net int show -is-home false` command to list the logical interfaces that are not on their home controller and port.

If any interfaces are listed as `false`, revert those interfaces back to their home port using the `net int revert -vserver Cluster -lif nodename` command.

16. Move the console cable to the target controller and run the `version -v` command to check the ONTAP versions.
17. Restore automatic giveback if you disabled it by using the `storage failover modify -node local -auto-giveback true` command.

## Restore NSE/NVE on systems running ONTAP 9.6 and later

### Steps

1. Connect the console cable to the target controller.
2. Use the `boot_ontap` command at the LOADER prompt to boot the controller.
3. Check the console output:

If the console displays...	Then...
The login prompt	Go to Step 7.

Waiting for giveback...

- a. Log into the partner controller.
- b. Confirm the target controller is ready for giveback with the `storage failover show` command.

4. Move the console cable to the partner controller and give back the target controller storage using the `storage failover giveback -fromnode local -only-cfo-aggregates true local` command.
  - If the command fails because of a failed disk, physically disengage the failed disk, but leave the disk in the slot until a replacement is received.
  - If the command fails because of an open CIFS sessions, check with customer how to close out CIFS sessions.



Terminating CIFS can cause loss of data.

- If the command fails because the partner "not ready", wait 5 minutes for the NVMEMs to synchronize.
  - If the command fails because of an NDMP, SnapMirror, or SnapVault process, disable the process. See the appropriate Documentation Center for more information.
5. Wait 3 minutes and check the failover status with the `storage failover show` command.
  6. At the clustershell prompt, enter the `net int show -is-home false` command to list the logical interfaces that are not on their home controller and port.

If any interfaces are listed as `false`, revert those interfaces back to their home port using the `net int revert -vserver Cluster -lif nodename` command.

7. Move the console cable to the target controller and run the `version -v` command to check the ONTAP versions.
8. Restore automatic giveback if you disabled it by using the `storage failover modify -node local -auto-giveback true` command.
9. Use the `storage encryption disk show` at the clustershell prompt, to review the output.
10. Use the `security key-manager key query` command to display the key IDs of the authentication keys that are stored on the key management servers.
  - If the `Restored` column = `yes/true`, you are done and can proceed to complete the replacement process.
  - If the `Key Manager type` = `external` and the `Restored` column = anything other than `yes/true`, use the `security key-manager external restore` command to restore the key IDs of the authentication keys.



If the command fails, contact Customer Support.

- If the `Key Manager type` = `onboard` and the `Restored` column = anything other than `yes/true`, use the `security key-manager onboard sync` command to re-sync the Key Manager type.

Use the `security key-manager key query` command to verify that the `Restored` column = `yes/true` for all authentication keys.

11. Connect the console cable to the partner controller.
12. Give back the controller using the `storage failover giveback -fromnode local` command.
13. Restore automatic giveback if you disabled it by using the `storage failover modify -node local -auto-giveback true` command.

## Return the failed part to NetApp - ASA A400

Return the failed part to NetApp, as described in the RMA instructions shipped with the kit. See the [Part Return and Replacements](#) page for further information.

### Chassis

#### Overview of chassis replacement - ASA A400

To replace the chassis, you must move the fans and controller modules from the impaired chassis to the new chassis of the same model as the impaired chassis.

All other components in the system must be functioning properly; if not, you must contact technical support.

- You can use this procedure with all versions of ONTAP supported by your system.
- This procedure is disruptive. For a two-node cluster, you will have a complete service outage and a partial outage in a multinode cluster.

#### Shut down the controllers - ASA A400

Shut down or take over the impaired controller using the appropriate procedure for your configuration.

#### Option 1: Shut down the controllers when replacing a chassis

This procedure is for 2-node, non-MetroCluster configurations only. If you have a system with more than two nodes, see [How to perform a graceful shutdown and power up of one HA pair in a 4-node cluster](#).

#### Before you begin

You need:

- Local administrator credentials for ONTAP.
- NetApp onboard key management (OKM) cluster-wide passphrase if using storage encryption or NVE/NAE.
- BMC accessibility for each controller.
- Stop all clients/host from accessing data on the NetApp system.
- Suspend external backup jobs.
- Necessary tools and equipment for the replacement.



If the system is a NetApp StorageGRID or ONTAP S3 used as FabricPool cloud tier, refer to the [Gracefully shutdown and power up your storage system Resolution Guide](#) after performing this procedure.





If using SSDs, refer to [SU490: \(Impact: Critical\) SSD Best Practices: Avoid risk of drive failure and data loss if powered off for more than two months](#)

As a best practice before shutdown, you should:

- Perform additional [system health checks](#).
- Upgrade ONTAP to a recommended release for the system.
- Resolve any [Active IQ Wellness Alerts and Risks](#).  
Make note of any faults presently on the system, such as LEDs on the system components.

### Steps

1. Log into the cluster through SSH or log in from any node in the cluster using a local console cable and a laptop/console.
2. Turn off AutoSupport and indicate how long you expect the system to be offline:

```
system node autosupport invoke -node * -type all -message "MAINT=8h Power Maintenance"
```

3. Identify the SP/BMC address of all nodes:

```
system service-processor show -node * -fields address
```

4. Exit the cluster shell: `exit`
5. Log into SP/BMC over SSH using the IP address of any of the nodes listed in the output from the previous step.

If you're using a console/laptop, log into the controller using the same cluster administrator credentials.



Open an SSH session to every SP/BMC connection so that you can monitor progress.

6. Halt the 2 nodes located in the impaired chassis:

```
system node halt -node <node>,<node2> -skip-lif-migration-before-shutdown true -ignore-quorum-warnings true -inhibit-takeover true
```



For clusters using SnapMirror synchronous operating in StrictSync mode: `system node halt -node <node>,<node2> -skip-lif-migration-before-shutdown true -ignore-quorum-warnings true -inhibit-takeover true -ignore-strict-sync-warnings true`

7. Enter **y** for each controller in the cluster when you see *Warning: Are you sure you want to halt node "cluster <node-name> number"?*  
{y|n}:
8. Wait for each controller to halt and display the LOADER prompt.

### Option 2: Shut down a controller in a two-node MetroCluster configuration

To shut down the impaired controller, you must determine the status of the controller and, if necessary, switch over the controller so that the healthy controller continues to serve data from the impaired controller storage.

## About this task

- You must leave the power supplies turned on at the end of this procedure to provide power to the healthy controller.

## Steps

1. Check the MetroCluster status to determine whether the impaired controller has automatically switched over to the healthy controller: `metrocluster show`
2. Depending on whether an automatic switchover has occurred, proceed according to the following table:

If the impaired controller...	Then...
Has automatically switched over	Proceed to the next step.
Has not automatically switched over	Perform a planned switchover operation from the healthy controller: <code>metrocluster switchover</code>
Has not automatically switched over, you attempted switchover with the <code>metrocluster switchover</code> command, and the switchover was vetoed	Review the veto messages and, if possible, resolve the issue and try again. If you are unable to resolve the issue, contact technical support.

3. Resynchronize the data aggregates by running the `metrocluster heal -phase aggregates` command from the surviving cluster.

```
controller_A_1::> metrocluster heal -phase aggregates
[Job 130] Job succeeded: Heal Aggregates is successful.
```

If the healing is vetoed, you have the option of reissuing the `metrocluster heal` command with the `-override-vetoes` parameter. If you use this optional parameter, the system overrides any soft vetoes that prevent the healing operation.

4. Verify that the operation has been completed by using the `metrocluster operation show` command.

```
controller_A_1::> metrocluster operation show
  Operation: heal-aggregates
  State: successful
Start Time: 7/25/2016 18:45:55
  End Time: 7/25/2016 18:45:56
  Errors: -
```

5. Check the state of the aggregates by using the `storage aggregate show` command.

```

controller_A_1::> storage aggregate show
Aggregate      Size Available Used% State   #Vols  Nodes           RAID
Status
-----
...
aggr_b2       227.1GB   227.1GB   0% online    0 mcc1-a2
raid_dp, mirrored, normal...

```

6. Heal the root aggregates by using the `metrocluster heal -phase root-aggregates` command.

```

mcc1A::> metrocluster heal -phase root-aggregates
[Job 137] Job succeeded: Heal Root Aggregates is successful

```

If the healing is vetoed, you have the option of reissuing the `metrocluster heal` command with the `-override-vetoes` parameter. If you use this optional parameter, the system overrides any soft vetoes that prevent the healing operation.

7. Verify that the heal operation is complete by using the `metrocluster operation show` command on the destination cluster:

```

mcc1A::> metrocluster operation show
Operation: heal-root-aggregates
State: successful
Start Time: 7/29/2016 20:54:41
End Time: 7/29/2016 20:54:42
Errors: -

```

8. On the impaired controller module, disconnect the power supplies.

## Replace hardware - ASA A400

Move the fans, hard drives, and controller module from the impaired chassis to the new chassis, and swap out the impaired chassis with the new chassis of the same model as the impaired chassis.

### Step 1: Remove the controller modules

To replace the chassis, you must remove the controller modules from the old chassis.

1. If you are not already grounded, properly ground yourself.
2. Release the power cable retainers, and then unplug the cables from the power supplies.
3. Loosen the hook and loop strap binding the cables to the cable management device, and then unplug the system cables and SFPs (if needed) from the controller module, keeping track of where the cables were connected.

Leave the cables in the cable management device so that when you reinstall the cable management device, the cables are organized.

4. Remove and set aside the cable management devices from the left and right sides of the controller module.
5. Press down on both of the locking latches, and then rotate both latches downward at the same time.

The controller module moves slightly out of the chassis.

6. Slide the controller module out of the chassis.

Make sure that you support the bottom of the controller module as you slide it out of the chassis.

7. Set the controller module aside in a safe place, and repeat these steps for the other controller module in the chassis.

## Step 2: Move the fans

To move the fan modules to the replacement chassis when replacing the chassis, you must perform a specific sequence of tasks.

1. If you are not already grounded, properly ground yourself.
2. Remove the bezel (if necessary) with two hands, by grasping the openings on each side of the bezel, and then pulling it toward you until the bezel releases from the ball studs on the chassis frame.
3. Press down the release latch on the fan module cam handle, and then rotate the cam handle downward.

The fan module moves a little bit away from the chassis.

4. Pull the fan module straight out from the chassis, making sure that you support it with your free hand so that it does not swing out of the chassis.



The fan modules are short. Always support the bottom of the fan module with your free hand so that it does not suddenly drop free from the chassis and injure you.

5. Set the fan module aside.
6. Repeat the preceding steps for any remaining fan modules.
7. Insert the fan module into the replacement chassis by aligning it with the opening, and then sliding it into the chassis.
8. Push firmly on the fan module cam handle so that it is seated all the way into the chassis.

The cam handle raises slightly when the fan module is completely seated.

9. Swing the cam handle up to its closed position, making sure that the cam handle release latch clicks into the locked position.
10. Repeat these steps for the remaining fan modules.

## Step 3: Replace a chassis from within the equipment rack or system cabinet

You must remove the existing chassis from the equipment rack or system cabinet before you can install the replacement chassis.

1. Remove the screws from the chassis mount points.

2. With two people, slide the old chassis off the rack rails in a system cabinet or equipment rack, and then set it aside.
3. If you are not already grounded, properly ground yourself.
4. Using two people, install the replacement chassis into the equipment rack or system cabinet by guiding the chassis onto the rack rails in a system cabinet or equipment rack.
5. Slide the chassis all the way into the equipment rack or system cabinet.
6. Secure the front of the chassis to the equipment rack or system cabinet, using the screws you removed from the old chassis.
7. If you have not already done so, install the bezel.

#### Step 4: Install the controller modules

After you install the controller modules into the new chassis, you need to boot it.

For HA pairs with two controller modules in the same chassis, the sequence in which you install the controller module is especially important because it attempts to reboot as soon as you completely seat it in the chassis.

1. Align the end of the controller module with the opening in the chassis, and then gently push the controller module halfway into the system.



Do not completely insert the controller module in the chassis until instructed to do so.

2. Recable the console to the controller module, and then reconnect the management port.
3. Complete the installation of the controller module:
  - a. Plug the power cord into the power supply, reinstall the power cable locking collar, and then connect the power supply to the power source.
  - b. Using the locking latches, firmly push the controller module into the chassis until the locking latches begin to rise.



Do not use excessive force when sliding the controller module into the chassis to avoid damaging the connectors.

- c. Fully seat the controller module in the chassis by rotating the locking latches upward, tilting them so that they clear the locking pins, gently push the controller all the way in, and then lower the locking latches into the locked position.

The controller module begins to boot as soon as it is fully seated in the chassis. Be prepared to interrupt the boot process.

- d. If you have not already done so, reinstall the cable management device.
- e. Interrupt the normal boot process and boot to LOADER by pressing `Ctrl-C`.



If your system stops at the boot menu, select the option to boot to LOADER.

- f. At the LOADER prompt, enter `bye` to reinitialize the PCIe cards and other components.
- g. Interrupt the boot process and boot to the LOADER prompt by pressing `Ctrl-C`.

If your system stops at the boot menu, select the option to boot to LOADER.

4. Repeat the preceding steps to install the second controller into the new chassis.

### Complete chassis replacement - ASA A400

You must verify the HA state of the chassis and return the failed part to NetApp, as described in the RMA instructions shipped with the kit.

#### Step 1: Verify and set the HA state of the chassis

You must verify the HA state of the chassis, and, if necessary, update the state to match your system configuration.

1. In Maintenance mode, from either controller module, display the HA state of the local controller module and chassis: `ha-config show`

The HA state should be the same for all components.

2. If the displayed system state for the chassis does not match your system configuration:

- a. Set the HA state for the chassis: `ha-config modify chassis HA-state`

The value for *HA-state* can be one of the following:

- `ha`
- `mcc`
- `mcc-2n`
- `mccip`
- `non-ha`

- b. Confirm that the setting has changed: `ha-config show`

3. If you have not already done so, recable the rest of your system.
4. Reinstall the bezel on the front of the system.

#### Step 2: Switch back aggregates in a two-node MetroCluster configuration

After you have completed the FRU replacement in a two-node MetroCluster configuration, you can perform the MetroCluster switchback operation. This returns the configuration to its normal operating state, with the sync-source storage virtual machines (SVMs) on the formerly impaired site now active and serving data from the local disk pools.

This task only applies to two-node MetroCluster configurations.

#### Steps

1. Verify that all nodes are in the `enabled state`: `metrocluster node show`

```

cluster_B::> metrocluster node show

DR
Group Cluster Node          Configuration State          DR
Mirroring Mode
-----
1      cluster_A
      controller_A_1 configured      enabled      heal roots
completed
      cluster_B
      controller_B_1 configured      enabled      waiting for
switchback recovery
2 entries were displayed.

```

2. Verify that resynchronization is complete on all SVMs: `metrocluster vserver show`
3. Verify that any automatic LIF migrations being performed by the healing operations were completed successfully: `metrocluster check lif show`
4. Perform the switchback by using the `metrocluster switchback` command from any node in the surviving cluster.
5. Verify that the switchback operation has completed: `metrocluster show`

The switchback operation is still running when a cluster is in the `waiting-for-switchback` state:

```

cluster_B::> metrocluster show
Cluster          Configuration State          Mode
-----
Local: cluster_B configured      switchover
Remote: cluster_A configured      waiting-for-switchback

```

The switchback operation is complete when the clusters are in the `normal` state.:

```

cluster_B::> metrocluster show
Cluster          Configuration State          Mode
-----
Local: cluster_B configured      normal
Remote: cluster_A configured      normal

```

If a switchback is taking a long time to finish, you can check on the status of in-progress baselines by using the `metrocluster config-replication resync-status show` command.

6. Reestablish any SnapMirror or SnapVault configurations.

### Step 3: Return the failed part to NetApp

Return the failed part to NetApp, as described in the RMA instructions shipped with the kit. See the [Part Return and Replacements](#) page for further information.

#### Controller

#### Overview of controller replacement - ASA A400

You must review the prerequisites for the replacement procedure and select the correct one for your version of the ONTAP operating system.

- All drive shelves must be working properly.
- If your system is in a MetroCluster configuration, you must review the section [Choosing the correct recovery procedure](#) to determine whether you should use this procedure.

If this is the procedure you should use, note that the controller replacement procedure for a controller in a four or eight node MetroCluster configuration is the same as that in an HA pair. No MetroCluster-specific steps are required because the failure is restricted to an HA pair and storage failover commands can be used to provide nondisruptive operation during the replacement.

- You must replace the failed component with a replacement FRU component you received from your provider.
- You must be replacing a controller module with a controller module of the same model type. You cannot upgrade your system by just replacing the controller module.
- You cannot change any drives or drive shelves as part of this procedure.
- In this procedure, the boot device is moved from the impaired controller to the *replacement* controller so that the *replacement* controller will boot up in the same version of ONTAP as the old controller module.
- It is important that you apply the commands in these steps on the correct systems:
  - The *impaired* controller is the controller that is being replaced.
  - The *replacement node* is the new controller that is replacing the impaired controller.
  - The *healthy* controller is the surviving controller.
- You must always capture the controller's console output to a text file.

This provides you a record of the procedure so that you can troubleshoot any issues that you might encounter during the replacement process.

#### Shut down the impaired controller - ASA A400

Shut down or take over the impaired controller using the appropriate procedure for your configuration.



## Option 1: Most systems

To shut down the impaired controller, you must determine the status of the controller and, if necessary, take over the controller so that the healthy controller continues to serve data from the impaired controller storage.

### About this task

- If you have a SAN system, you must have checked event messages (`cluster kernel-service show`) for the impaired controller SCSI blade. The `cluster kernel-service show` command (from `priv advanced` mode) displays the node name, quorum status of that node, availability status of that node, and operational status of that node.

Each SCSI-blade process should be in quorum with the other nodes in the cluster. Any issues must be resolved before you proceed with the replacement.

- If you have a cluster with more than two nodes, it must be in quorum. If the cluster is not in quorum or a healthy controller shows false for eligibility and health, you must correct the issue before shutting down the impaired controller; see [Synchronize a node with the cluster](#).

### Steps

1. If AutoSupport is enabled, suppress automatic case creation by invoking an AutoSupport message:

```
system node autosupport invoke -node * -type all -message MAINT=<# of hours>h
```

The following AutoSupport message suppresses automatic case creation for two hours: `cluster1:>`

```
system node autosupport invoke -node * -type all -message MAINT=2h
```

2. Disable automatic giveback from the console of the healthy controller: `storage failover modify -node local -auto-giveback false`



When you see *Do you want to disable auto-giveback?*, enter *y*.

3. Take the impaired controller to the LOADER prompt:

If the impaired controller is displaying...	Then...
The LOADER prompt	Go to the next step.
Waiting for giveback...	Press Ctrl-C, and then respond <i>y</i> when prompted.
System prompt or password prompt	Take over or halt the impaired controller from the healthy controller: <code>storage failover takeover -ofnode <i>impaired_node_name</i></code>  When the impaired controller shows Waiting for giveback..., press Ctrl-C, and then respond <i>y</i> .

## Option 2: Controller is in a two-node MetroCluster

To shut down the impaired controller, you must determine the status of the controller and, if necessary,

switch over the controller so that the healthy controller continues to serve data from the impaired controller storage.

### About this task

- You must leave the power supplies turned on at the end of this procedure to provide power to the healthy controller.

### Steps

1. Check the MetroCluster status to determine whether the impaired controller has automatically switched over to the healthy controller: `metrocluster show`
2. Depending on whether an automatic switchover has occurred, proceed according to the following table:

If the impaired controller...	Then...
Has automatically switched over	Proceed to the next step.
Has not automatically switched over	Perform a planned switchover operation from the healthy controller: <code>metrocluster switchover</code>
Has not automatically switched over, you attempted switchover with the <code>metrocluster switchover</code> command, and the switchover was vetoed	Review the veto messages and, if possible, resolve the issue and try again. If you are unable to resolve the issue, contact technical support.

3. Resynchronize the data aggregates by running the `metrocluster heal -phase aggregates` command from the surviving cluster.

```
controller_A_1::> metrocluster heal -phase aggregates
[Job 130] Job succeeded: Heal Aggregates is successful.
```

If the healing is vetoed, you have the option of reissuing the `metrocluster heal` command with the `-override-vetoes` parameter. If you use this optional parameter, the system overrides any soft vetoes that prevent the healing operation.

4. Verify that the operation has been completed by using the `metrocluster operation show` command.

```
controller_A_1::> metrocluster operation show
  Operation: heal-aggregates
  State: successful
Start Time: 7/25/2016 18:45:55
End Time: 7/25/2016 18:45:56
Errors: -
```

5. Check the state of the aggregates by using the `storage aggregate show` command.

```

controller_A_1::> storage aggregate show
Aggregate      Size Available Used% State   #Vols  Nodes
RAID Status
-----
...
aggr_b2       227.1GB   227.1GB   0% online    0 mcc1-a2
raid_dp, mirrored, normal...

```

6. Heal the root aggregates by using the `metrocluster heal -phase root-aggregates` command.

```

mcc1A::> metrocluster heal -phase root-aggregates
[Job 137] Job succeeded: Heal Root Aggregates is successful

```

If the healing is vetoed, you have the option of reissuing the `metrocluster heal` command with the `-override-vetoes` parameter. If you use this optional parameter, the system overrides any soft vetoes that prevent the healing operation.

7. Verify that the heal operation is complete by using the `metrocluster operation show` command on the destination cluster:

```

mcc1A::> metrocluster operation show
Operation: heal-root-aggregates
State: successful
Start Time: 7/29/2016 20:54:41
End Time: 7/29/2016 20:54:42
Errors: -

```

8. On the impaired controller module, disconnect the power supplies.

## Replace the controller - ASA A400

To replace the controller module hardware, you must remove the impaired controller, move FRU components to the replacement controller module, install the replacement controller module in the chassis, and then boot the system to Maintenance mode.

### Step 1: Remove the controller module

To access components inside the controller module, you must remove the controller module from the chassis.

1. If you are not already grounded, properly ground yourself.
2. Release the power cable retainers, and then unplug the cables from the power supplies.
3. Loosen the hook and loop strap binding the cables to the cable management device, and then unplug the

system cables and SFPs (if needed) from the controller module, keeping track of where the cables were connected.

Leave the cables in the cable management device so that when you reinstall the cable management device, the cables are organized.

4. Remove the cable management device from the controller module and set it aside.
5. Press down on both of the locking latches, and then rotate both latches downward at the same time.

The controller module moves slightly out of the chassis.

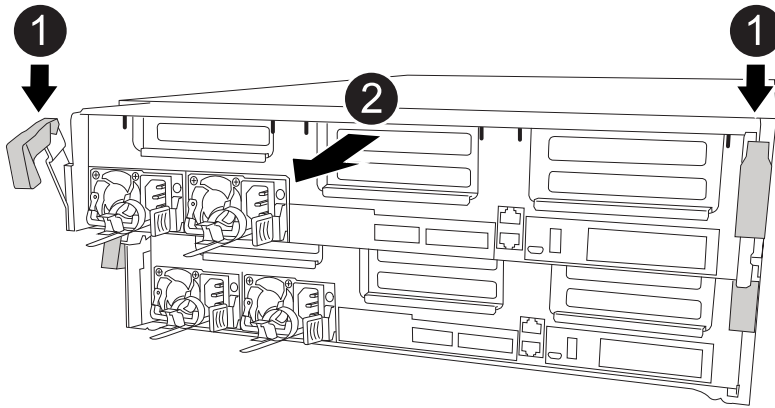

<b>1</b>	Locking latches
<b>2</b>	Controller moves slightly out of chassis

6. Slide the controller module out of the chassis.

Make sure that you support the bottom of the controller module as you slide it out of the chassis.

7. Place the controller module on a stable, flat surface.
8. On the replacement controller module, open the air duct and remove the empty risers from the controller module using the animation, illustration, or the written steps:

[Animation - Remove the empty risers from the replacement controller module](#)

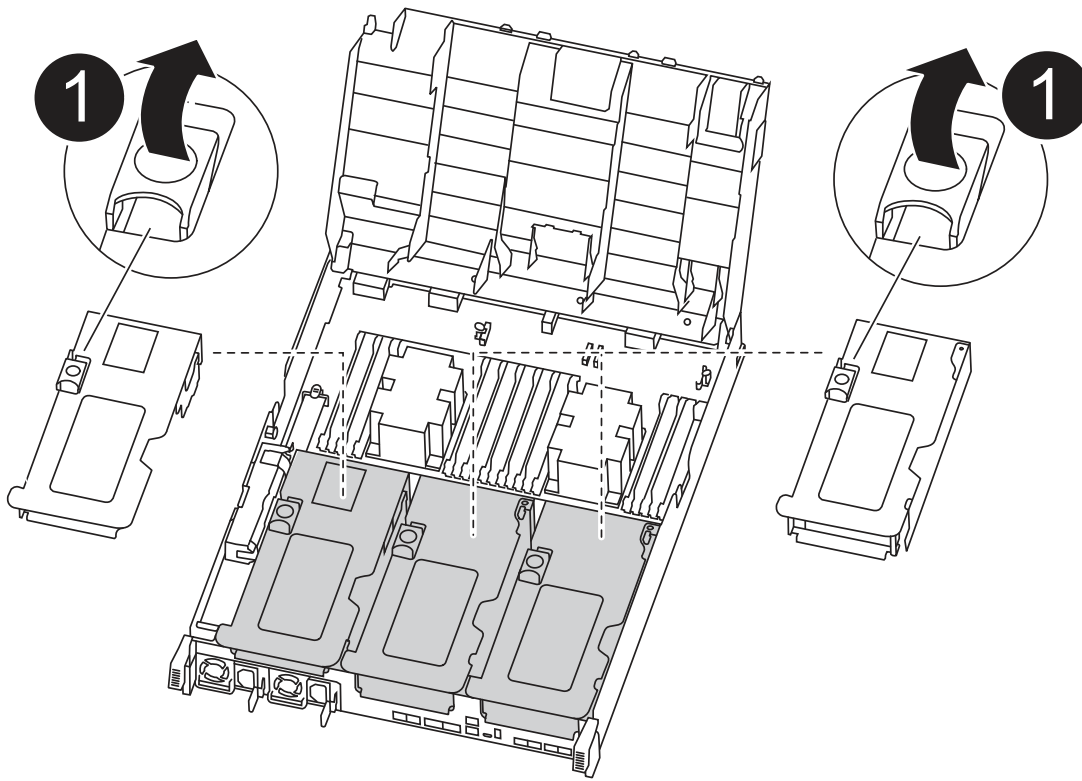

1

#### Riser latches

- a. Press the locking tabs on the sides of the air duct in toward the middle of the controller module.
- b. Slide the air duct toward the back of the controller module, and then rotate it upward to its completely open position.
- c. Rotate the riser locking latch on the left side of riser 1 up and toward air duct, lift the riser up, and then set it aside.
- d. Repeat the previous step for the remaining risers.

### Step 2: Move the power supplies

You must move the power supply from the impaired controller module to the replacement controller module when you replace a controller module.

You can use the following animation, illustration, or the written steps to move the power supplies to the replacement controller module.

#### [Animation - Move the power supplies](#)

1. Remove the power supply:

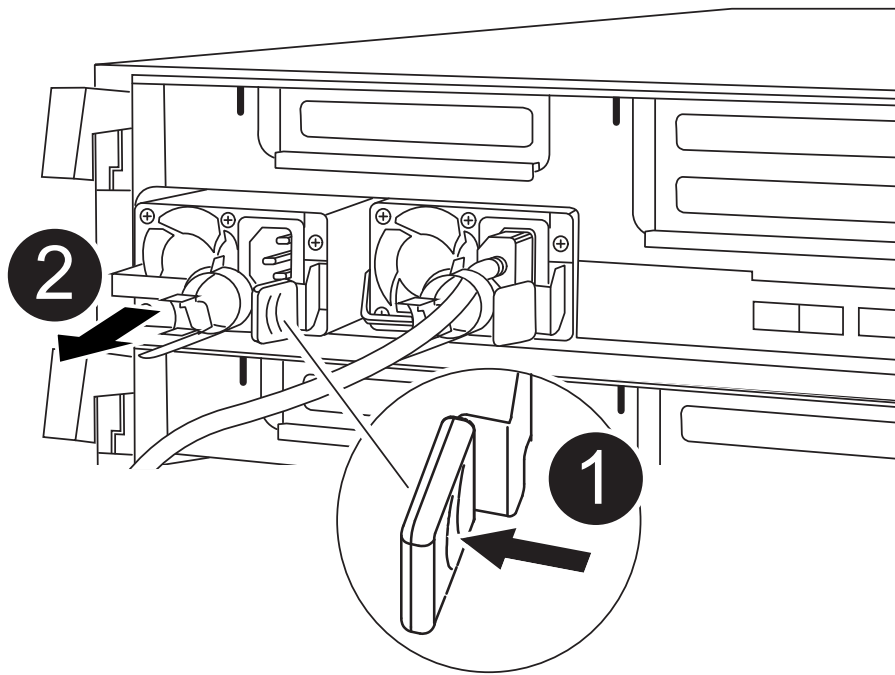

1	PSU locking tab
2	Power cable retainer

- a. Rotate the cam handle so that it can be used to pull the power supply out of the chassis.
- b. Press the blue locking tab to release the power supply from the chassis.
- c. Using both hands, pull the power supply out of the chassis, and then set it aside.
  1. Move the power supply to the new controller module, and then install it.
  2. Using both hands, support and align the edges of the power supply with the opening in the controller module, and then gently push the power supply into the controller module until the locking tab clicks into place.

The power supplies will only properly engage with the internal connector and lock in place one way.



To avoid damaging the internal connector, do not use excessive force when sliding the power supply into the system.

3. Repeat the preceding steps for any remaining power supplies.

### Step 3: Move the NVDIMM battery

To move the NVDIMM battery from the impaired controller module to the replacement controller module, you must perform a specific sequence of steps.

You can use the following animation, illustration, or the written steps to move the NVDIMM battery from the impaired controller module to the replacement controller module.

## Animation - Move the NVDIMM battery

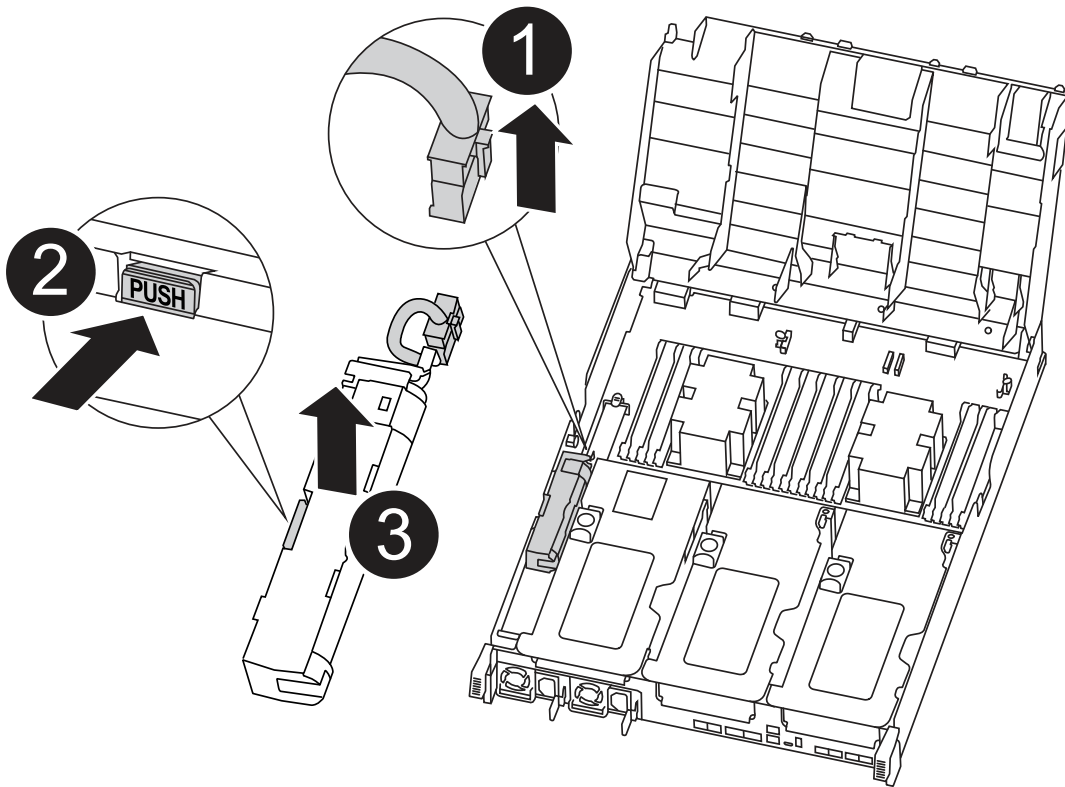

1	NVDIMM battery plug
2	NVDIMM battery locking tab
3	NVDIMM battery

1. Open the air duct:
  - a. Press the locking tabs on the sides of the air duct in toward the middle of the controller module.
  - b. Slide the air duct toward the back of the controller module, and then rotate it upward to its completely open position.
2. Locate the NVDIMM battery in the controller module.
3. Locate the battery plug and squeeze the clip on the face of the battery plug to release the plug from the socket, and then unplug the battery cable from the socket.
4. Grasp the battery and press the blue locking tab marked PUSH, and then lift the battery out of the holder and controller module.
5. Move the battery to the replacement controller module.
6. Align the battery module with the opening for the battery, and then gently push the battery into slot until it locks into place.



Do not plug the battery cable back into the motherboard until instructed to do so.

#### Step 4: Move the boot media

You must locate the boot media, and then follow the directions to remove it from the impaired controller module and insert it into the replacement controller module.

You can use the following animation, illustration, or the written steps to move the boot media from the impaired controller module to the replacement controller module.

#### Animation - Move the boot media

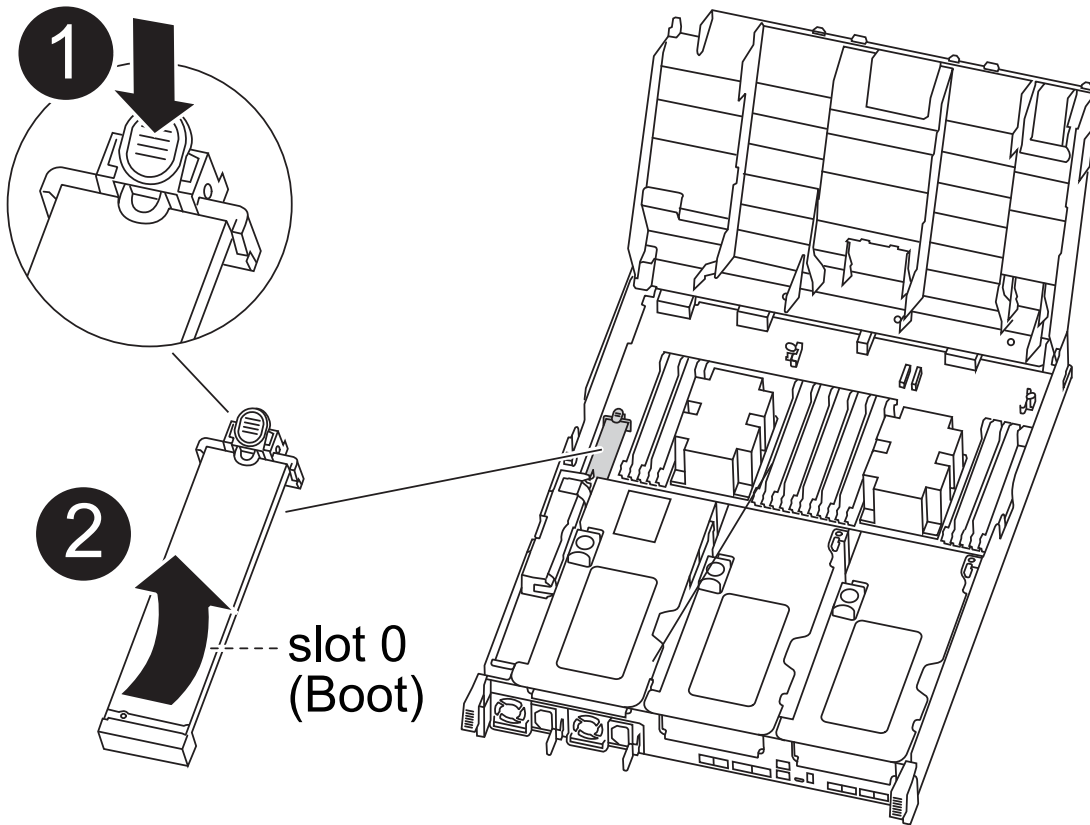

1	Boot media locking tab
2	Boot media

1. Locate and remove the boot media from the controller module:
  - a. Press the blue button at the end of the boot media until the lip on the boot media clears the blue button.
  - b. Rotate the boot media up and gently pull the boot media out of the socket.
2. Move the boot media to the new controller module, align the edges of the boot media with the socket housing, and then gently push it into the socket.
3. Check the boot media to make sure that it is seated squarely and completely in the socket.

If necessary, remove the boot media and reseal it into the socket.

4. Lock the boot media in place:



- a. Rotate the boot media down toward the motherboard.
- b. Press the blue locking button so that it is in the open position.
- c. Placing your fingers at the end of the boot media by the blue button, firmly push down on the boot media end to engage the blue locking button.

### Step 5: Move the PCIe risers and mezzanine card

As part of the controller replacement process, you must move the PCIe risers and mezzanine card from the impaired controller module to the replacement controller module.

You can use the following animations, illustrations, or the written steps to move the PCIe risers and mezzanine card from the impaired controller module to the replacement controller module.

Moving PCIe riser 1 and 2 (left and middle risers):

[Animation - Move PCI risers 1 and 2](#)

Moving the mezzanine card and riser 3 (right riser):

[Animation - Move the mezzanine card and riser 3](#)

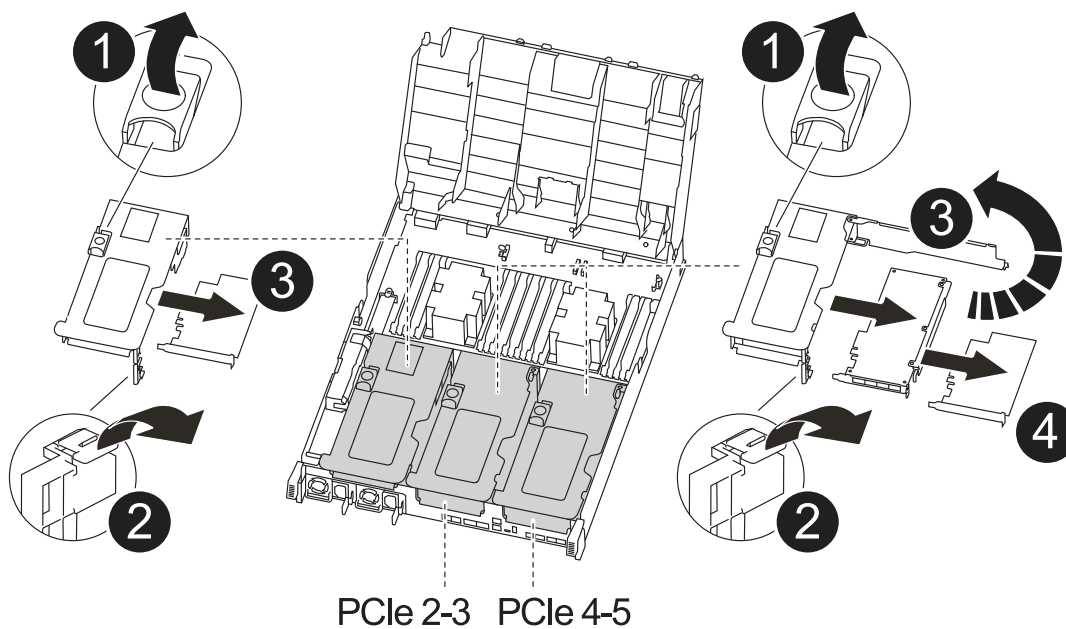

1	Riser locking latch
2	PCI card locking latch
3	PCI locking plate
4	PCI card

1. Move PCIe risers one and two from the impaired controller module to the replacement controller module:
  - a. Remove any SFP or QSFP modules that might be in the PCIe cards.
  - b. Rotate the riser locking latch on the left side of the riser up and toward air duct.

The riser raises up slightly from the controller module.

- c. Lift the riser up, and then move it to the replacement controller module.
  - d. Align the riser with the pins to the side of the riser socket, lower the riser down on the pins, push the riser squarely into the socket on the motherboard, and then rotate the latch down flush with the sheet metal on the riser.
  - e. Repeat this step for riser number 2.
2. Remove riser number 3, remove the mezzanine card, and install both into the replacement controller module:
  - a. Remove any SFP or QSFP modules that might be in the PCIe cards.
  - b. Rotate the riser locking latch on the left side of the riser up and toward air duct.

The riser raises up slightly from the controller module.

- c. Lift the riser up, and then set it aside on a stable, flat surface.
  - d. Loosen the thumbscrews on the mezzanine card, and gently lift the card directly out of the socket, and then move it to the replacement controller module.
  - e. Install the mezzanine in the replacement controller and secure it with the thumbscrews.
  - f. Install the third riser in the replacement controller module.

## **Step 6: Move the DIMMs**

You need to locate the DIMMs, and then move them from the impaired controller module to the replacement controller module.

You must have the new controller module ready so that you can move the DIMMs directly from the impaired controller module to the corresponding slots in the replacement controller module.

You can use the following animation, illustration, or the written steps to move the DIMMs from the impaired controller module to the replacement controller module.

[Animation - Move the DIMMs](#)

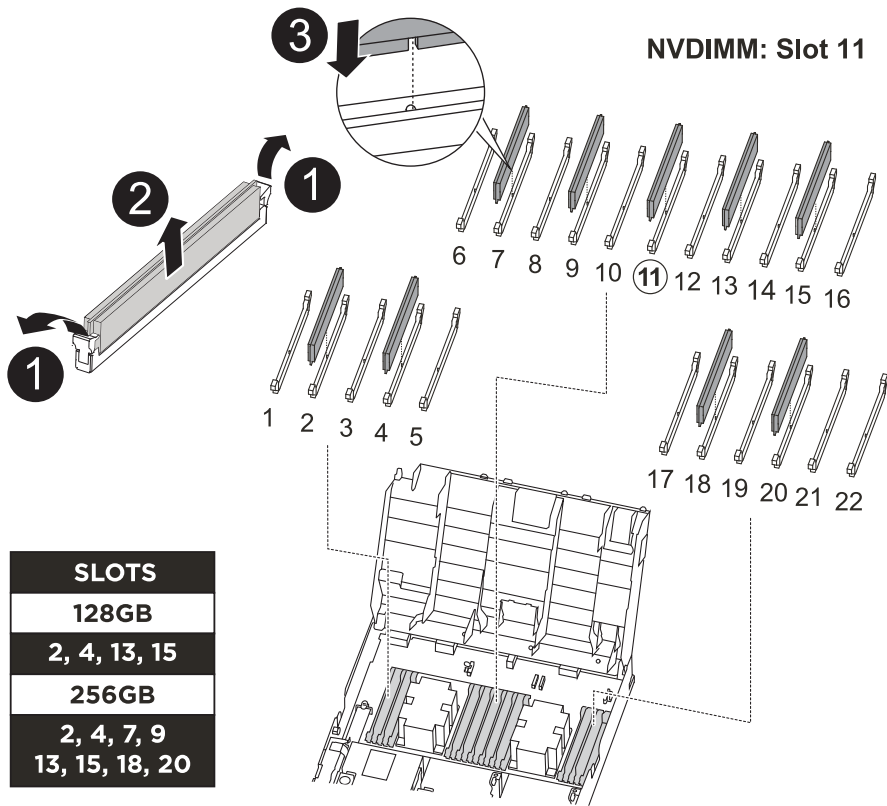

<b>1</b>	DIMM locking tabs
<b>2</b>	DIMM
<b>3</b>	DIMM socket

1. Locate the DIMMs on your controller module.
2. Note the orientation of the DIMM in the socket so that you can insert the DIMM in the replacement controller module in the proper orientation.
3. Verify that the NVDIMM battery is not plugged into the new controller module.
4. Move the DIMMs from the impaired controller module to the replacement controller module:



Make sure that you install the each DIMM into the same slot it occupied in the impaired controller module.

- a. Eject the DIMM from its slot by slowly pushing apart the DIMM ejector tabs on either side of the DIMM, and then slide the DIMM out of the slot.



Carefully hold the DIMM by the edges to avoid pressure on the components on the DIMM circuit board.

- b. Locate the corresponding DIMM slot on the replacement controller module.
- c. Make sure that the DIMM ejector tabs on the DIMM socket are in the open position, and then insert the

DIMM squarely into the socket.

The DIMMs fit tightly in the socket, but should go in easily. If not, realign the DIMM with the socket and reinsert it.

- d. Visually inspect the DIMM to verify that it is evenly aligned and fully inserted into the socket.
  - e. Repeat these substeps for the remaining DIMMs.
5. Plug the NVDIMM battery into the motherboard.

Make sure that the plug locks down onto the controller module.

### Step 7: Install the controller module

After all of the components have been moved from the impaired controller module to the replacement controller module, you must install the replacement controller module into the chassis, and then boot it to Maintenance mode.

1. If you have not already done so, close the air duct.
2. Align the end of the controller module with the opening in the chassis, and then gently push the controller module halfway into the system.



Do not completely insert the controller module in the chassis until instructed to do so.

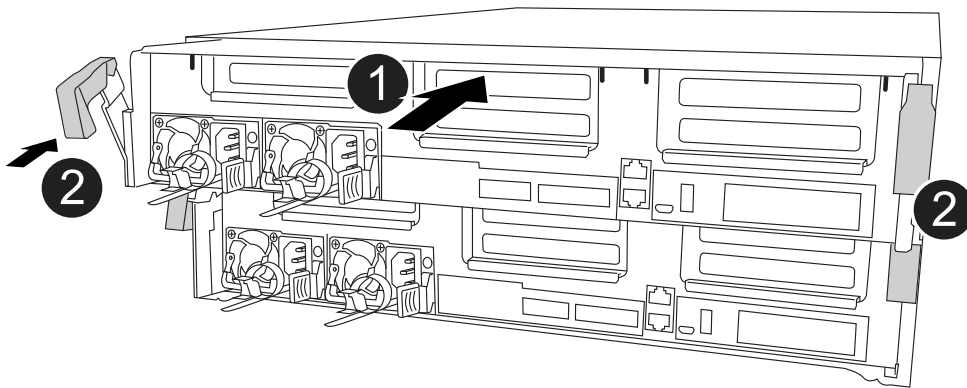

<b>1</b>	Slide controller into the chassis
<b>2</b>	Locking latches

3. Cable the management and console ports only, so that you can access the system to perform the tasks in the following sections.



You will connect the rest of the cables to the controller module later in this procedure.

4. Complete the installation of the controller module:

- a. Plug the power cord into the power supply, reinstall the power cable locking collar, and then connect the power supply to the power source.
- b. Using the locking latches, firmly push the controller module into the chassis until the locking latches begin to rise.



Do not use excessive force when sliding the controller module into the chassis to avoid damaging the connectors.

- c. Fully seat the controller module in the chassis by rotating the locking latches upward, tilting them so that they clear the locking pins, gently push the controller all the way in, and then lower the locking latches into the locked position.

The controller module begins to boot as soon as it is fully seated in the chassis. Be prepared to interrupt the boot process.

- d. If you have not already done so, reinstall the cable management device.
- e. Interrupt the normal boot process and boot to LOADER by pressing `Ctrl-C`.



If your system stops at the boot menu, select the option to boot to LOADER.

- f. At the LOADER prompt, enter `bye` to reinitialize the PCIe cards and other components.
- g. Interrupt the boot process and boot to the LOADER prompt by pressing `Ctrl-C`.

If your system stops at the boot menu, select the option to boot to LOADER.

## Restore and verify the system configuration - ASA A400

After completing the hardware replacement and booting to Maintenance mode, you verify the low-level system configuration of the replacement controller and reconfigure system settings as necessary.

### Step 1: Set and verify system time after replacing the controller

You should check the time and date on the replacement controller module against the healthy controller module in an HA pair, or against a reliable time server in a stand-alone configuration. If the time and date do not match, you must reset them on the replacement controller module to prevent possible outages on clients due to time differences.

#### About this task

It is important that you apply the commands in the steps on the correct systems:

- The *replacement* node is the new node that replaced the impaired node as part of this procedure.
- The *healthy* node is the HA partner of the *replacement* node.

#### Steps

1. If the *replacement* node is not at the LOADER prompt, halt the system to the LOADER prompt.
2. On the *healthy* node, check the system time: `cluster date show`

The date and time are based on the configured timezone.

3. At the LOADER prompt, check the date and time on the *replacement* node: `show date`

The date and time are given in GMT.

4. If necessary, set the date in GMT on the replacement node: `set date mm/dd/yyyy`
5. If necessary, set the time in GMT on the replacement node: `set time hh:mm:ss`
6. At the LOADER prompt, confirm the date and time on the *replacement* node: `show date`

The date and time are given in GMT.

## Step 2: Verify and set the HA state of the controller module

You must verify the HA state of the controller module and, if necessary, update the state to match your system configuration.

1. In Maintenance mode from the new controller module, verify that all components display the same HA state: `ha-config show`

The HA state should be the same for all components.

2. If the displayed system state of the controller module does not match your system configuration, set the HA state for the controller module: `ha-config modify controller ha-state`

The value for HA-state can be one of the following:

- `ha`
- `mcc`
- `mcc-2n`
- `mccip`
- `non-ha`

3. If the displayed system state of the controller module does not match your system configuration, set the HA state for the controller module: `ha-config modify controller ha-state`
4. Confirm that the setting has changed: `ha-config show`

## Recable the system and reassign disks - ASA A400

Continue the replacement procedure by recabling the storage and confirming disk reassignment.

### Step 1: Recable the system

Recable the controller module's storage and network connections.

#### Steps

1. Recable the the controller module to storage and network connections.
2. Verify that the cabling is correct by using [Active IQ Config Advisor](#).
  - a. Download and install Config Advisor.

- b. Enter the information for the target system, and then click Collect Data.
- c. Click the Cabling tab, and then examine the output. Make sure that all disk shelves are displayed and all disks appear in the output, correcting any cabling issues you find.
- d. Check other cabling by clicking the appropriate tab, and then examining the output from Config Advisor.

## Step 2: Reassign disks

If the storage system is in an HA pair, the system ID of the new controller module is automatically assigned to the disks when the giveback occurs at the end of the procedure. You must confirm the system ID change when you boot the *replacement* controller and then verify that the change was implemented.

This procedure applies only to systems running ONTAP in an HA pair.

1. If the *replacement* controller is in Maintenance mode (showing the `*>` prompt, exit Maintenance mode and go to the LOADER prompt: `halt`
2. From the LOADER prompt on the *replacement* controller, boot the controller, entering `y` if you are prompted to override the system ID due to a system ID mismatch: `boot_ontap`
3. Wait until the `Waiting for giveback...` message is displayed on the *replacement* controller console and then, from the healthy controller, verify that the new partner system ID has been automatically assigned: `storage failover show`

In the command output, you should see a message that the system ID has changed on the impaired controller, showing the correct old and new IDs. In the following example, node2 has undergone replacement and has a new system ID of 151759706.

```
node1> `storage failover show`
```

Node	Partner	Takeover Possible	State Description
node1	node2	false	System ID changed on partner (Old: 151759706), In takeover
node2	node1	-	Waiting for giveback (HA mailboxes)

4. From the healthy controller, verify that any coredumps are saved:
  - a. Change to the advanced privilege level: `set -privilege advanced`

You can respond `y` when prompted to continue into advanced mode. The advanced mode prompt appears (`*>`).

- b. Save any coredumps: `system node run -node local-node-name partner savecore`
- c. Wait for the `savecore` command to complete before issuing the giveback.

You can enter the following command to monitor the progress of the `savecore` command: `system`

```
node run -node local-node-name partner savecore -s
```

d. Return to the admin privilege level: `set -privilege admin`

5. If your storage system has Storage or Volume Encryption configured, you must restore Storage or Volume Encryption functionality by using one of the following procedures, depending on whether you are using onboard or external key management:

- [Restore onboard key management encryption keys](#)
- [Restore external key management encryption keys](#)

6. Give back the controller:

a. From the healthy controller, give back the replaced controller's storage: `storage failover giveback -ofnode replacement_node_name`

The *replacement* controller takes back its storage and completes booting.

If you are prompted to override the system ID due to a system ID mismatch, you should enter `y`.



If the giveback is vetoed, you can consider overriding the vetoes.

[Find the High-Availability Configuration content for your version of ONTAP 9](#)

b. After the giveback has been completed, confirm that the HA pair is healthy and that takeover is possible: `storage failover show`

The output from the `storage failover show` command should not include the System ID changed on partner message.

7. Verify that the disks were assigned correctly: `storage disk show -ownership`

The disks belonging to the *replacement* controller should show the new system ID. In the following example, the disks owned by node1 now show the new system ID, 1873775277:

```
node1> `storage disk show -ownership`

Disk Aggregate Home Owner DR Home Home ID Owner ID DR Home ID
Reserver Pool
-----
-----
-----
1.0.0 aggr0_1 node1 node1 - 1873775277 1873775277 -
1873775277 Pool0
1.0.1 aggr0_1 node1 node1 1873775277 1873775277 -
1873775277 Pool0
.
.
.
```

8. If the system is in a MetroCluster configuration, monitor the status of the controller: `metrocluster node show`



The MetroCluster configuration takes a few minutes after the replacement to return to a normal state, at which time each controller will show a configured state, with DR Mirroring enabled and a mode of normal. The `metrocluster node show -fields node-systemid` command output displays the old system ID until the MetroCluster configuration returns to a normal state.

9. If the controller is in a MetroCluster configuration, depending on the MetroCluster state, verify that the DR home ID field shows the original owner of the disk if the original owner is a controller on the disaster site.

This is required if both of the following are true:

- The MetroCluster configuration is in a switchover state.
- The *replacement* controller is the current owner of the disks on the disaster site.

[Disk ownership changes during HA takeover and MetroCluster switchover in a four-node MetroCluster configuration](#)

10. If your system is in a MetroCluster configuration, verify that each controller is configured: `metrocluster node show -fields configuration-state`

```
node1_siteA::> metrocluster node show -fields configuration-state

dr-group-id          cluster node          configuration-state
-----
-----
1 node1_siteA        node1mcc-001         configured
1 node1_siteA        node1mcc-002         configured
1 node1_siteB        node1mcc-003         configured
1 node1_siteB        node1mcc-004         configured

4 entries were displayed.
```

11. Verify that the expected volumes are present for each controller: `vol show -node node-name`
12. If you disabled automatic takeover on reboot, enable it from the healthy controller: `storage failover modify -node replacement-node-name -onreboot true`

## Complete system restoration - ASA A400

To restore your system to full operation, you must restore the NetApp Storage Encryption configuration (if necessary), and install licenses for the new controller, and return the failed part to NetApp, as described in the RMA instructions shipped with the kit.

### Step 1: Install licenses for the replacement controller in ONTAP

You must install new licenses for the *replacement* node if the impaired node was using ONTAP features that require a standard (node-locked) license. For features with standard licenses, each node in the cluster should have its own key for the feature.

#### About this task

Until you install license keys, features requiring standard licenses continue to be available to the *replacement*

node. However, if the impaired node was the only node in the cluster with a license for the feature, no configuration changes to the feature are allowed. Also, using unlicensed features on the node might put you out of compliance with your license agreement, so you should install the replacement license key or keys on the *replacement* node as soon as possible.

### Before you begin

The licenses keys must be in the 28-character format.

You have a 90-day grace period in which to install the license keys. After the grace period, all old licenses are invalidated. After a valid license key is installed, you have 24 hours to install all of the keys before the grace period ends.

### Steps

1. If you need new license keys, obtain replacement license keys on the [NetApp Support Site](#) in the My Support section under Software licenses.



The new license keys that you require are automatically generated and sent to the email address on file. If you fail to receive the email with the license keys within 30 days, you should contact technical support.

2. Install each license key: `system license add -license-code license-key, license-key...`
3. Remove the old licenses, if desired:
  - a. Check for unused licenses: `license clean-up -unused -simulate`
  - b. If the list looks correct, remove the unused licenses: `license clean-up -unused`

### Step 2: Verify LIFs and registering the serial number

Before returning the *replacement* node to service, you should verify that the LIFs are on their home ports, and register the serial number of the *replacement* node if AutoSupport is enabled, and reset automatic giveback.

### Steps

1. Verify that the logical interfaces are reporting to their home server and ports: `network interface show -is-home false`  
  
If any LIFs are listed as false, revert them to their home ports: `network interface revert -vserver * -lif *`
2. Register the system serial number with NetApp Support.
  - If AutoSupport is enabled, send an AutoSupport message to register the serial number.
  - If AutoSupport is not enabled, call [NetApp Support](#) to register the serial number.
3. If an AutoSupport maintenance window was triggered, end it by using the `system node autosupport invoke -node * -type all -message MAINT=END` command.
4. If automatic giveback was disabled, reenable it: `storage failover modify -node local -auto-giveback true`

### Step 3: Switch back aggregates in a two-node MetroCluster configuration

After you have completed the FRU replacement in a two-node MetroCluster configuration, you can perform the MetroCluster switchback operation. This returns the configuration to its normal operating state, with the sync-

source storage virtual machines (SVMs) on the formerly impaired site now active and serving data from the local disk pools.

This task only applies to two-node MetroCluster configurations.

### Steps

1. Verify that all nodes are in the enabled state: `metrocluster node show`

```
cluster_B::> metrocluster node show

DR                               Configuration  DR
Group Cluster Node              State          Mirroring Mode
-----
1      cluster_A
      controller_A_1 configured      enabled      heal roots
completed
      cluster_B
      controller_B_1 configured      enabled      waiting for
switchback recovery
2 entries were displayed.
```

2. Verify that resynchronization is complete on all SVMs: `metrocluster vserver show`
3. Verify that any automatic LIF migrations being performed by the healing operations were completed successfully: `metrocluster check lif show`
4. Perform the switchback by using the `metrocluster switchback` command from any node in the surviving cluster.
5. Verify that the switchback operation has completed: `metrocluster show`

The switchback operation is still running when a cluster is in the `waiting-for-switchback` state:

```
cluster_B::> metrocluster show

Cluster          Configuration State      Mode
-----
Local: cluster_B configured      switchover
Remote: cluster_A configured      waiting-for-switchback
```

The switchback operation is complete when the clusters are in the `normal` state.:

```

cluster_B::> metrocluster show
Cluster              Configuration State      Mode
-----
Local: cluster_B configured          normal
Remote: cluster_A configured        normal

```

If a switchback is taking a long time to finish, you can check on the status of in-progress baselines by using the `metrocluster config-replication resync-status show` command.

6. Reestablish any SnapMirror or SnapVault configurations.

#### Step 4: Return the failed part to NetApp

Return the failed part to NetApp, as described in the RMA instructions shipped with the kit. See the [Part Return and Replacements](#) page for further information.

#### Replace DIMM - ASA A400

You must replace a DIMM in the controller module when your system registers an increasing number of correctable error correction codes (ECC); failure to do so causes a system panic.

All other components in the system must be functioning properly; if not, you must contact technical support.

You must replace the failed component with a replacement FRU component you received from your provider.

#### Step 1: Shut down the impaired controller

Shut down or take over the impaired controller using the appropriate procedure for your configuration.

## Option 1: Most configurations

To shut down the impaired controller, you must determine the status of the controller and, if necessary, take over the controller so that the healthy controller continues to serve data from the impaired controller storage.

### About this task

- If you have a SAN system, you must have checked event messages (`cluster kernel-service show`) for the impaired controller SCSI blade. The `cluster kernel-service show` command (from `priv advanced` mode) displays the node name, quorum status of that node, availability status of that node, and operational status of that node.

Each SCSI-blade process should be in quorum with the other nodes in the cluster. Any issues must be resolved before you proceed with the replacement.

- If you have a cluster with more than two nodes, it must be in quorum. If the cluster is not in quorum or a healthy controller shows false for eligibility and health, you must correct the issue before shutting down the impaired controller; see [Synchronize a node with the cluster](#).

### Steps

1. If AutoSupport is enabled, suppress automatic case creation by invoking an AutoSupport message:  

```
system node autosupport invoke -node * -type all -message MAINT=<# of hours>h
```

The following AutoSupport message suppresses automatic case creation for two hours: `cluster1:>`  

```
system node autosupport invoke -node * -type all -message MAINT=2h
```

2. Disable automatic giveback from the console of the healthy controller: 

```
storage failover modify -node local -auto-giveback false
```



When you see *Do you want to disable auto-giveback?*, enter *y*.

3. Take the impaired controller to the LOADER prompt:

If the impaired controller is displaying...	Then...
The LOADER prompt	Go to the next step.
Waiting for giveback...	Press Ctrl-C, and then respond <i>y</i> when prompted.
System prompt or password prompt	Take over or halt the impaired controller from the healthy controller: <pre>storage failover takeover -ofnode impaired_node_name</pre> When the impaired controller shows Waiting for giveback..., press Ctrl-C, and then respond <i>y</i> .

## Option 2: Controller is in a two-node MetroCluster

To shut down the impaired controller, you must determine the status of the controller and, if necessary,

switch over the controller so that the healthy controller continues to serve data from the impaired controller storage.

### About this task

- You must leave the power supplies turned on at the end of this procedure to provide power to the healthy controller.

### Steps

1. Check the MetroCluster status to determine whether the impaired controller has automatically switched over to the healthy controller: `metrocluster show`
2. Depending on whether an automatic switchover has occurred, proceed according to the following table:

If the impaired controller...	Then...
Has automatically switched over	Proceed to the next step.
Has not automatically switched over	Perform a planned switchover operation from the healthy controller: <code>metrocluster switchover</code>
Has not automatically switched over, you attempted switchover with the <code>metrocluster switchover</code> command, and the switchover was vetoed	Review the veto messages and, if possible, resolve the issue and try again. If you are unable to resolve the issue, contact technical support.

3. Resynchronize the data aggregates by running the `metrocluster heal -phase aggregates` command from the surviving cluster.

```
controller_A_1::> metrocluster heal -phase aggregates
[Job 130] Job succeeded: Heal Aggregates is successful.
```

If the healing is vetoed, you have the option of reissuing the `metrocluster heal` command with the `-override-vetoes` parameter. If you use this optional parameter, the system overrides any soft vetoes that prevent the healing operation.

4. Verify that the operation has been completed by using the `metrocluster operation show` command.

```
controller_A_1::> metrocluster operation show
  Operation: heal-aggregates
  State: successful
Start Time: 7/25/2016 18:45:55
End Time: 7/25/2016 18:45:56
Errors: -
```

5. Check the state of the aggregates by using the `storage aggregate show` command.

```

controller_A_1::> storage aggregate show
Aggregate      Size Available Used% State   #Vols  Nodes
RAID Status
-----
...
aggr_b2       227.1GB   227.1GB   0% online    0 mcc1-a2
raid_dp, mirrored, normal...

```

6. Heal the root aggregates by using the `metrocluster heal -phase root-aggregates` command.

```

mcc1A::> metrocluster heal -phase root-aggregates
[Job 137] Job succeeded: Heal Root Aggregates is successful

```

If the healing is vetoed, you have the option of reissuing the `metrocluster heal` command with the `-override-vetoes` parameter. If you use this optional parameter, the system overrides any soft vetoes that prevent the healing operation.

7. Verify that the heal operation is complete by using the `metrocluster operation show` command on the destination cluster:

```

mcc1A::> metrocluster operation show
Operation: heal-root-aggregates
State: successful
Start Time: 7/29/2016 20:54:41
End Time: 7/29/2016 20:54:42
Errors: -

```

8. On the impaired controller module, disconnect the power supplies.

## Step 2: Remove the controller module

To access components inside the controller module, you must remove the controller module from the chassis.

1. If you are not already grounded, properly ground yourself.
2. Release the power cable retainers, and then unplug the cables from the power supplies.
3. Loosen the hook and loop strap binding the cables to the cable management device, and then unplug the system cables and SFPs (if needed) from the controller module, keeping track of where the cables were connected.

Leave the cables in the cable management device so that when you reinstall the cable management device, the cables are organized.

4. Remove the cable management device from the controller module and set it aside.

5. Press down on both of the locking latches, and then rotate both latches downward at the same time.

The controller module moves slightly out of the chassis.

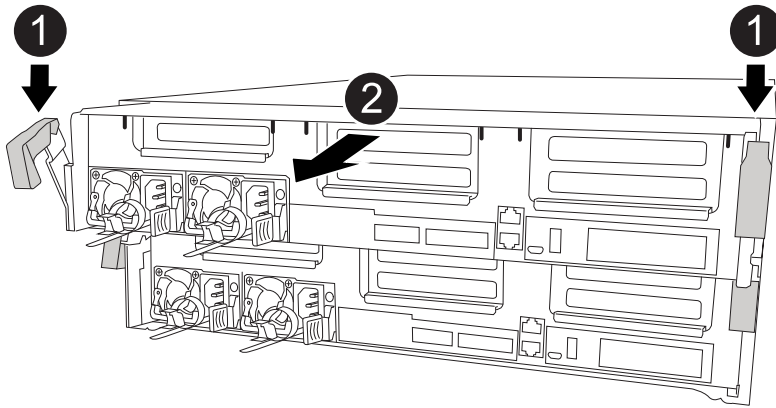

<b>1</b>	Locking latches
<b>2</b>	Controller moves slightly out of chassis

6. Slide the controller module out of the chassis.

Make sure that you support the bottom of the controller module as you slide it out of the chassis.

7. Place the controller module on a stable, flat surface.

### Step 3: Replace system DIMMs

Replacing a system DIMM involves identifying the target DIMM through the associated error message, locating the target DIMM using the FRU map on the air duct, and then replacing the DIMM.

You can use the following animation, illustration, or the written steps to replace a system DIMM.



The animation and illustration show empty slots for sockets without DIMMs. These empty sockets are populated with blanks.

[Animation - Replace a system DIMM](#)



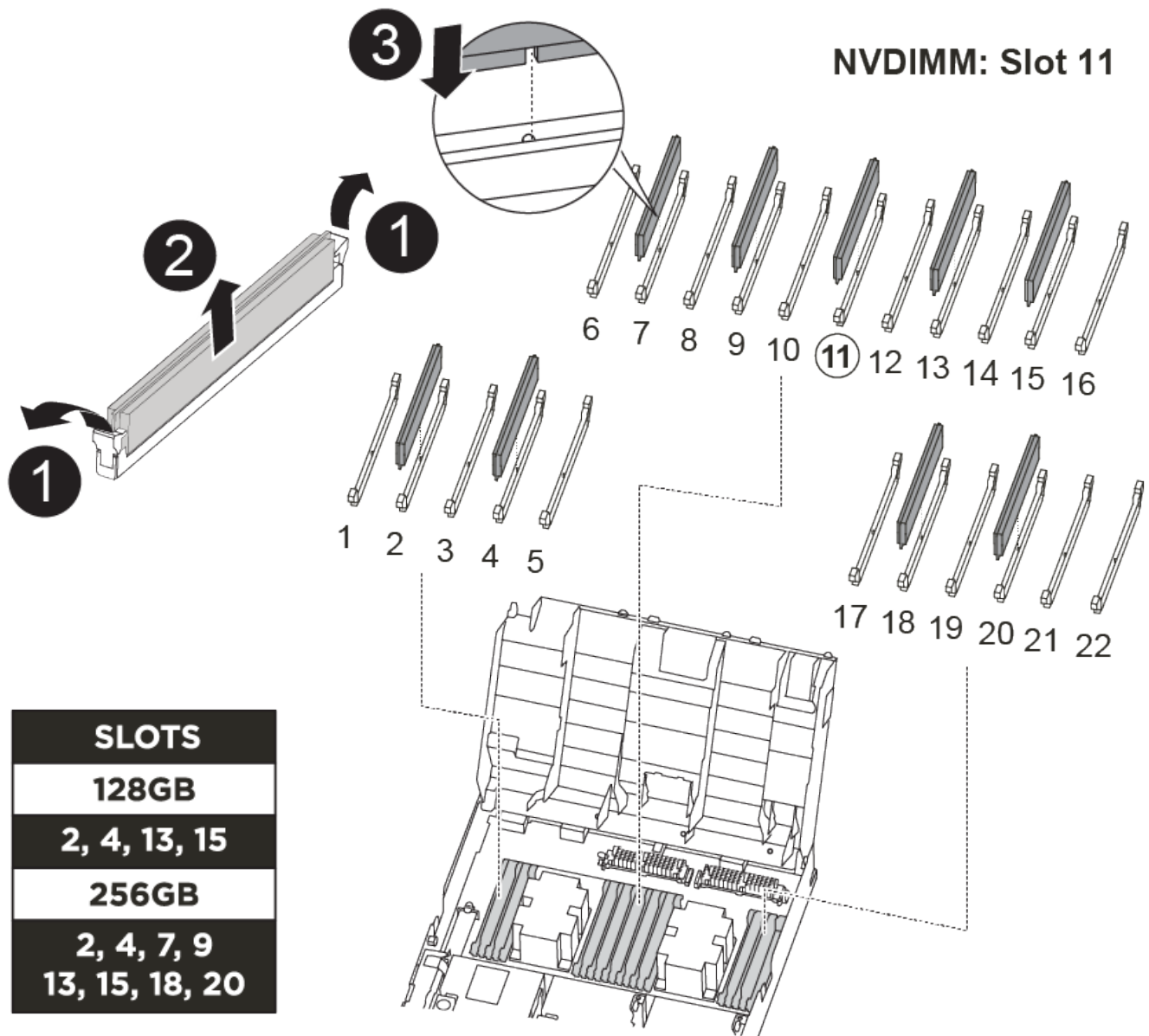

<b>1</b>	DIMM locking tabs
<b>2</b>	DIMM
<b>3</b>	DIMM socket

The DIMMs are located in sockets 2, 4, 13, and 15. The NVDIMM is located in slot 11.

1. Open the air duct:
  - a. Press the locking tabs on the sides of the air duct in toward the middle of the controller module.
  - b. Slide the air duct toward the back of the controller module, and then rotate it upward to its completely open position.

2. Locate the DIMMs on your controller module.
3. Note the orientation of the DIMM in the socket so that you can insert the replacement DIMM in the proper orientation.
4. Eject the DIMM from its socket by slowly pushing apart the two DIMM ejector tabs on either side of the DIMM, and then slide the DIMM out of the socket.



Carefully hold the DIMM by the edges to avoid pressure on the components on the DIMM circuit board.

5. Remove the replacement DIMM from the antistatic shipping bag, hold the DIMM by the corners, and align it to the slot.

The notch among the pins on the DIMM should line up with the tab in the socket.

6. Make sure that the DIMM ejector tabs on the connector are in the open position, and then insert the DIMM squarely into the slot.

The DIMM fits tightly in the slot, but should go in easily. If not, realign the DIMM with the slot and reinsert it.



Visually inspect the DIMM to verify that it is evenly aligned and fully inserted into the slot.

7. Push carefully, but firmly, on the top edge of the DIMM until the ejector tabs snap into place over the notches at the ends of the DIMM.
8. Close the air duct.

#### Step 4: Install the controller module

After you have replaced the component in the controller module, you must reinstall the controller module into the chassis, and then boot it to Maintenance mode.

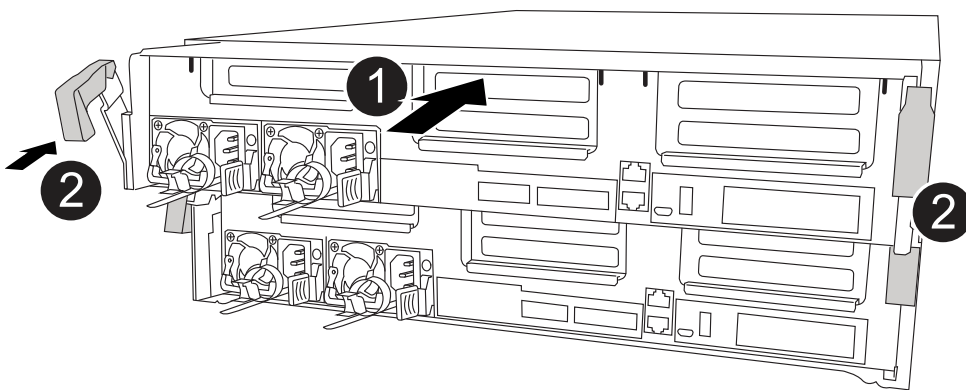

<b>1</b>	Controller module
<b>2</b>	Controller locking latches

1. If you have not already done so, close the air duct.
2. Align the end of the controller module with the opening in the chassis, and then gently push the controller module halfway into the system.



Do not completely insert the controller module in the chassis until instructed to do so.

3. Cable the management and console ports only, so that you can access the system to perform the tasks in the following sections.



You will connect the rest of the cables to the controller module later in this procedure.

4. Complete the installation of the controller module:
  - a. Plug the power cord into the power supply, reinstall the power cable locking collar, and then connect the power supply to the power source.
  - b. Using the locking latches, firmly push the controller module into the chassis until the locking latches begin to rise.



Do not use excessive force when sliding the controller module into the chassis to avoid damaging the connectors.

- c. Fully seat the controller module in the chassis by rotating the locking latches upward, tilting them so that they clear the locking pins, gently push the controller all the way in, and then lower the locking latches into the locked position.

The controller module begins to boot as soon as it is fully seated in the chassis. Be prepared to interrupt the boot process.

- d. If you have not already done so, reinstall the cable management device.
- e. Interrupt the normal boot process and boot to LOADER by pressing `Ctrl-C`.



If your system stops at the boot menu, select the option to boot to LOADER.

- f. At the LOADER prompt, enter `bye` to reinitialize the PCIe cards and other components.
- g. Interrupt the boot process and boot to the LOADER prompt by pressing `Ctrl-C`.

If your system stops at the boot menu, select the option to boot to LOADER.

## Step 5: Restore the controller module to operation

You must recable the system, give back the controller module, and then reenabling automatic giveback.

1. Recable the system, as needed.

If you removed the media converters (QSFPs or SFPs), remember to reinstall them if you are using fiber optic cables.

2. Return the controller to normal operation by giving back its storage: `storage failover giveback -ofnode impaired_node_name`
3. If automatic giveback was disabled, reenabling it: `storage failover modify -node local -auto`

```
-giveback true
```

## Step 6: Switch back aggregates in a two-node MetroCluster configuration

After you have completed the FRU replacement in a two-node MetroCluster configuration, you can perform the MetroCluster switchback operation. This returns the configuration to its normal operating state, with the sync-source storage virtual machines (SVMs) on the formerly impaired site now active and serving data from the local disk pools.

This task only applies to two-node MetroCluster configurations.

### Steps

1. Verify that all nodes are in the enabled state: `metrocluster node show`

```
cluster_B::> metrocluster node show

DR                               Configuration  DR
Group Cluster Node              State          Mirroring Mode
-----
1      cluster_A
      controller_A_1 configured      enabled  heal roots
completed
      cluster_B
      controller_B_1 configured      enabled  waiting for
switchback recovery
2 entries were displayed.
```

2. Verify that resynchronization is complete on all SVMs: `metrocluster vserver show`
3. Verify that any automatic LIF migrations being performed by the healing operations were completed successfully: `metrocluster check lif show`
4. Perform the switchback by using the `metrocluster switchback` command from any node in the surviving cluster.
5. Verify that the switchback operation has completed: `metrocluster show`

The switchback operation is still running when a cluster is in the `waiting-for-switchback` state:

```
cluster_B::> metrocluster show

Cluster              Configuration State      Mode
-----
Local: cluster_B configured      switchover
Remote: cluster_A configured      waiting-for-switchback
```

The switchback operation is complete when the clusters are in the `normal` state.:

```
cluster_B::> metrocluster show
Cluster              Configuration State      Mode
-----
Local: cluster_B configured          normal
Remote: cluster_A configured          normal
```

If a switchback is taking a long time to finish, you can check on the status of in-progress baselines by using the `metrocluster config-replication resync-status show` command.

6. Reestablish any SnapMirror or SnapVault configurations.

### Step 7: Return the failed part to NetApp

Return the failed part to NetApp, as described in the RMA instructions shipped with the kit. See the [Part Return and Replacements](#) page for further information.

#### Hot-swap a fan module - ASA A400

To swap out a fan module without interrupting service, you must perform a specific sequence of tasks.



You must replace the fan module within two minutes of removing it from the chassis. System airflow is disrupted and the controller module or modules shut down after two minutes to avoid overheating.

You can use the following animation, illustration, or the written steps to hot-swap a fan module.

[Animation - Replace a fan](#)

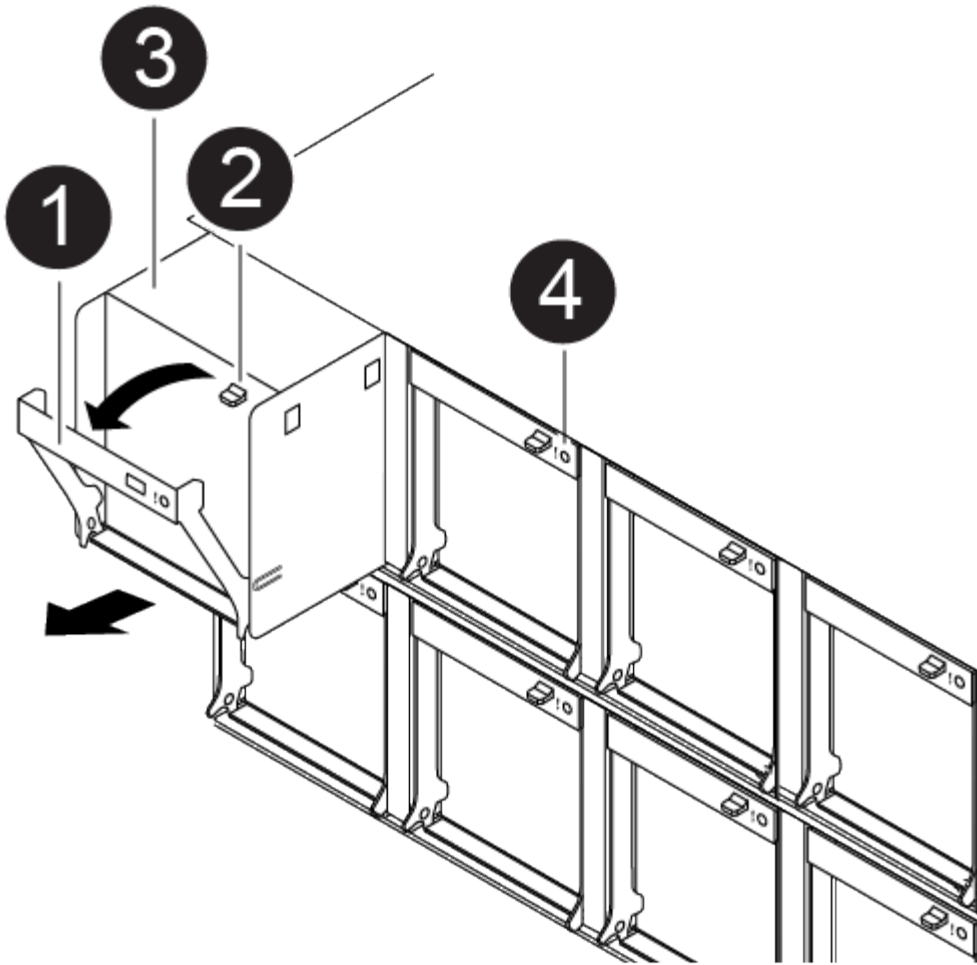

1	Fan handle
2	Locking tab
3	Fan
4	Status LED

1. If you are not already grounded, properly ground yourself.
2. Remove the bezel (if necessary) with two hands, by grasping the openings on each side of the bezel, and then pulling it toward you until the bezel releases from the ball studs on the chassis frame.
3. Identify the fan module that you must replace by checking the console error messages and looking at the Attention LED on each fan module.
4. Press down the release latch on the fan module cam handle, and then rotate the cam handle downward.

The fan module moves a little bit away from the chassis.

5. Pull the fan module straight out from the chassis, making sure that you support it with your free hand so that it does not swing out of the chassis.



The fan modules are short. Always support the bottom of the fan module with your free hand so that it does not suddenly drop free from the chassis and injure you.

6. Set the fan module aside.
7. Insert the replacement fan module into the chassis by aligning it with the opening, and then sliding it into the chassis.
8. Push firmly on the fan module cam handle so that it is seated all the way into the chassis.

The cam handle raises slightly when the fan module is completely seated.

9. Swing the cam handle up to its closed position, making sure that the cam handle release latch clicks into the locked position.

The Attention LED should not be lit after the fan is seated and has spun up to operational speed.

10. Align the bezel with the ball studs, and then gently push the bezel onto the ball studs.
11. Return the failed part to NetApp, as described in the RMA instructions shipped with the kit. See the [Part Return and Replacements](#) page for further information.

#### **Replace the NVDIMM battery - ASA A400**

To replace the NVDIMM battery, you must remove the controller module, remove the battery, replace the battery, and then reinstall the controller module.

All other components in the system must be functioning properly; if not, you must contact technical support.

#### **Step 1: Shut down the impaired controller**

You can shut down or take over the impaired controller using different procedures, depending on the storage system hardware configuration.

### Option 1: Most configurations

To shut down the impaired controller, you must determine the status of the controller and, if necessary, take over the controller so that the healthy controller continues to serve data from the impaired controller storage.

#### About this task

- If you have a SAN system, you must have checked event messages (`cluster kernel-service show`) for the impaired controller SCSI blade. The `cluster kernel-service show` command (from `priv advanced` mode) displays the node name, quorum status of that node, availability status of that node, and operational status of that node.

Each SCSI-blade process should be in quorum with the other nodes in the cluster. Any issues must be resolved before you proceed with the replacement.

- If you have a cluster with more than two nodes, it must be in quorum. If the cluster is not in quorum or a healthy controller shows false for eligibility and health, you must correct the issue before shutting down the impaired controller; see [Synchronize a node with the cluster](#).

#### Steps

1. If AutoSupport is enabled, suppress automatic case creation by invoking an AutoSupport message:

```
system node autosupport invoke -node * -type all -message MAINT=<# of hours>h
```

The following AutoSupport message suppresses automatic case creation for two hours: `cluster1:>`

```
system node autosupport invoke -node * -type all -message MAINT=2h
```

2. Disable automatic giveback from the console of the healthy controller: `storage failover modify -node local -auto-giveback false`



When you see *Do you want to disable auto-giveback?*, enter *y*.

3. Take the impaired controller to the LOADER prompt:

If the impaired controller is displaying...	Then...
The LOADER prompt	Go to the next step.
Waiting for giveback...	Press Ctrl-C, and then respond <i>y</i> when prompted.
System prompt or password prompt	Take over or halt the impaired controller from the healthy controller: <code>storage failover takeover -ofnode <i>impaired_node_name</i></code>  When the impaired controller shows Waiting for giveback..., press Ctrl-C, and then respond <i>y</i> .

### Option 2: Controller is in a two-node MetroCluster

To shut down the impaired controller, you must determine the status of the controller and, if necessary,



switch over the controller so that the healthy controller continues to serve data from the impaired controller storage.

### About this task

- You must leave the power supplies turned on at the end of this procedure to provide power to the healthy controller.

### Steps

1. Check the MetroCluster status to determine whether the impaired controller has automatically switched over to the healthy controller: `metrocluster show`
2. Depending on whether an automatic switchover has occurred, proceed according to the following table:

If the impaired controller...	Then...
Has automatically switched over	Proceed to the next step.
Has not automatically switched over	Perform a planned switchover operation from the healthy controller: <code>metrocluster switchover</code>
Has not automatically switched over, you attempted switchover with the <code>metrocluster switchover</code> command, and the switchover was vetoed	Review the veto messages and, if possible, resolve the issue and try again. If you are unable to resolve the issue, contact technical support.

3. Resynchronize the data aggregates by running the `metrocluster heal -phase aggregates` command from the surviving cluster.

```
controller_A_1::> metrocluster heal -phase aggregates
[Job 130] Job succeeded: Heal Aggregates is successful.
```

If the healing is vetoed, you have the option of reissuing the `metrocluster heal` command with the `-override-vetoes` parameter. If you use this optional parameter, the system overrides any soft vetoes that prevent the healing operation.

4. Verify that the operation has been completed by using the `metrocluster operation show` command.

```
controller_A_1::> metrocluster operation show
  Operation: heal-aggregates
  State: successful
Start Time: 7/25/2016 18:45:55
End Time: 7/25/2016 18:45:56
Errors: -
```

5. Check the state of the aggregates by using the `storage aggregate show` command.

```

controller_A_1::> storage aggregate show
Aggregate      Size Available Used% State   #Vols  Nodes
RAID Status
-----
...
aggr_b2       227.1GB   227.1GB   0% online    0 mcc1-a2
raid_dp, mirrored, normal...

```

6. Heal the root aggregates by using the `metrocluster heal -phase root-aggregates` command.

```

mcc1A::> metrocluster heal -phase root-aggregates
[Job 137] Job succeeded: Heal Root Aggregates is successful

```

If the healing is vetoed, you have the option of reissuing the `metrocluster heal` command with the `-override-vetoes` parameter. If you use this optional parameter, the system overrides any soft vetoes that prevent the healing operation.

7. Verify that the heal operation is complete by using the `metrocluster operation show` command on the destination cluster:

```

mcc1A::> metrocluster operation show
Operation: heal-root-aggregates
State: successful
Start Time: 7/29/2016 20:54:41
End Time: 7/29/2016 20:54:42
Errors: -

```

8. On the impaired controller module, disconnect the power supplies.

## Step 2: Remove the controller module

To access components inside the controller module, you must remove the controller module from the chassis.

1. If you are not already grounded, properly ground yourself.
2. Release the power cable retainers, and then unplug the cables from the power supplies.
3. Loosen the hook and loop strap binding the cables to the cable management device, and then unplug the system cables and SFPs (if needed) from the controller module, keeping track of where the cables were connected.

Leave the cables in the cable management device so that when you reinstall the cable management device, the cables are organized.

4. Remove the cable management device from the controller module and set it aside.

5. Press down on both of the locking latches, and then rotate both latches downward at the same time.

The controller module moves slightly out of the chassis.

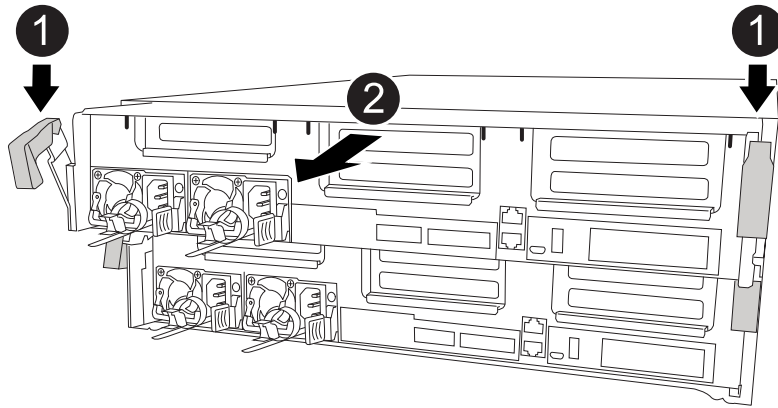

<b>1</b>	Locking latches
<b>2</b>	Controller moves slightly out of chassis

6. Slide the controller module out of the chassis.

Make sure that you support the bottom of the controller module as you slide it out of the chassis.

7. Place the controller module on a stable, flat surface.

### Step 3: Replace the NVDIMM battery

To replace the NVDIMM battery, you must remove the failed battery from the controller module and install the replacement battery into the controller module. See the FRU map inside the controller module to locate the NVDIMM battery.

The NVDIMM LED blinks while destaging contents when you halt the system. After the destage is complete, the LED turns off.

You can use the following animation, illustration, or the written steps to replace the NVDIMM battery.

[Animation - Replace the NVDIMM battery](#)

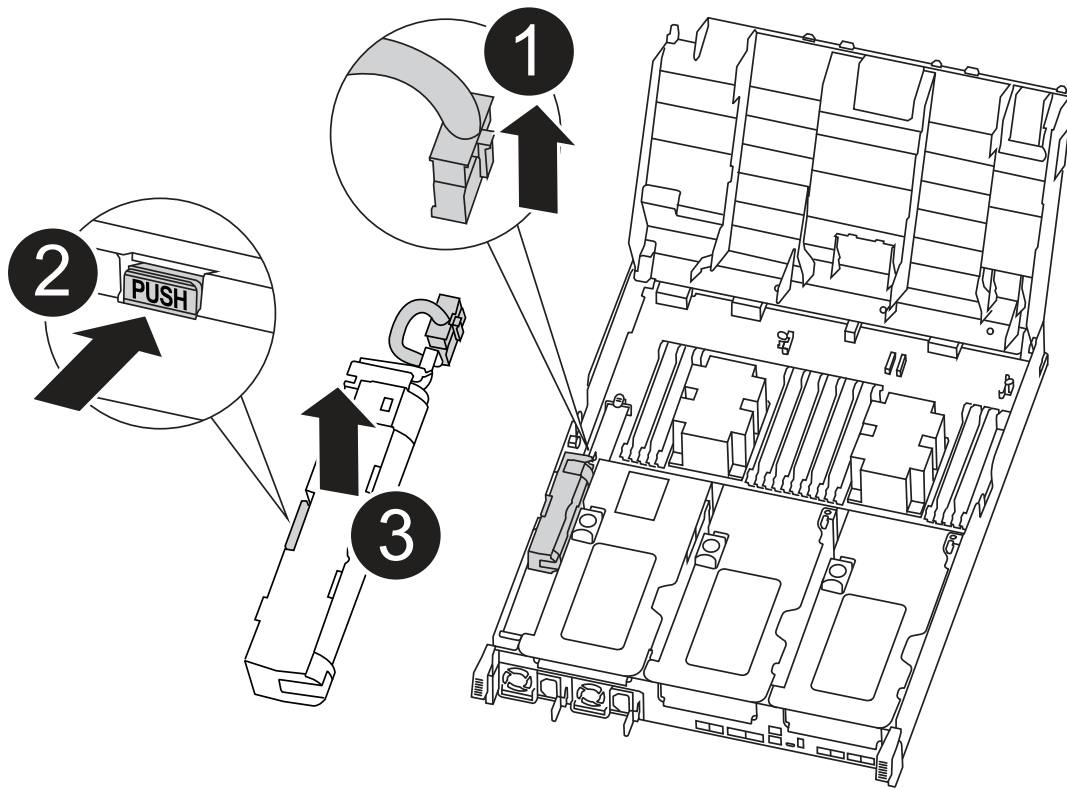

1	Battery plug
2	Locking tab
3	NVDIMM battery

1. Open the air duct:
  - a. Press the locking tabs on the sides of the air duct in toward the middle of the controller module.
  - b. Slide the air duct toward the back of the controller module, and then rotate it upward to its completely open position.
2. Locate the NVDIMM battery in the controller module.
3. Locate the battery plug and squeeze the clip on the face of the battery plug to release the plug from the socket, and then unplug the battery cable from the socket.
4. Grasp the battery and press the blue locking tab marked PUSH, and then lift the battery out of the holder and controller module.
5. Remove the replacement battery from its package.
6. Align the battery module with the opening for the battery, and then gently push the battery into slot until it locks into place.
7. Plug the battery plug back into the controller module, and then close the air duct.

## Step 4: Install the controller module

After you have replaced the component in the controller module, you must reinstall the controller module into the chassis, and then boot it to Maintenance mode.

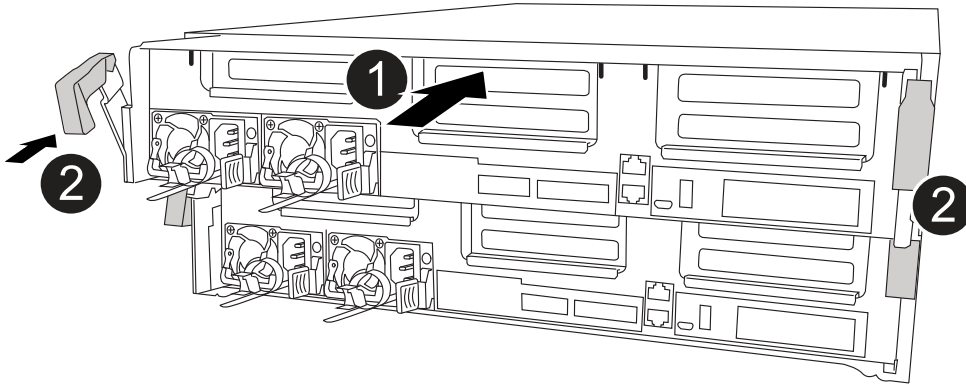

<b>1</b>	Controller module
<b>2</b>	Controller locking latches

1. If you have not already done so, close the air duct.
2. Align the end of the controller module with the opening in the chassis, and then gently push the controller module halfway into the system.



Do not completely insert the controller module in the chassis until instructed to do so.

3. Cable the management and console ports only, so that you can access the system to perform the tasks in the following sections.



You will connect the rest of the cables to the controller module later in this procedure.

4. Complete the installation of the controller module:
  - a. Plug the power cord into the power supply, reinstall the power cable locking collar, and then connect the power supply to the power source.
  - b. Using the locking latches, firmly push the controller module into the chassis until the locking latches begin to rise.



Do not use excessive force when sliding the controller module into the chassis to avoid damaging the connectors.

- c. Fully seat the controller module in the chassis by rotating the locking latches upward, tilting them so that they clear the locking pins, gently push the controller all the way in, and then lower the locking latches into the locked position.

The controller module begins to boot as soon as it is fully seated in the chassis. Be prepared to

interrupt the boot process.

- d. If you have not already done so, reinstall the cable management device.
- e. Interrupt the normal boot process and boot to LOADER by pressing `Ctrl-C`.



If your system stops at the boot menu, select the option to boot to LOADER.

- f. At the LOADER prompt, enter `bye` to reinitialize the PCIe cards and other components.
- g. Interrupt the boot process and boot to the LOADER prompt by pressing `Ctrl-C`.

If your system stops at the boot menu, select the option to boot to LOADER.

### Step 5: Restore the controller module to operation

You must recable the system, give back the controller module, and then reenables automatic giveback.

1. Recable the system, as needed.

If you removed the media converters (QSFPs or SFPs), remember to reinstall them if you are using fiber optic cables.

2. Return the controller to normal operation by giving back its storage: `storage failover giveback -ofnode impaired_node_name`
3. If automatic giveback was disabled, reenables it: `storage failover modify -node local -auto-giveback true`

### Step 6: Switch back aggregates in a two-node MetroCluster configuration

After you have completed the FRU replacement in a two-node MetroCluster configuration, you can perform the MetroCluster switchback operation. This returns the configuration to its normal operating state, with the sync-source storage virtual machines (SVMs) on the formerly impaired site now active and serving data from the local disk pools.

This task only applies to two-node MetroCluster configurations.

#### Steps

1. Verify that all nodes are in the `enabled state`: `metrocluster node show`

```

cluster_B::> metrocluster node show

DR
Group Cluster Node          Configuration  DR
-----
-----
1      cluster_A
      controller_A_1 configured      enabled      heal roots
completed
      cluster_B
      controller_B_1 configured      enabled      waiting for
switchback recovery
2 entries were displayed.

```

2. Verify that resynchronization is complete on all SVMs: `metrocluster vserver show`
3. Verify that any automatic LIF migrations being performed by the healing operations were completed successfully: `metrocluster check lif show`
4. Perform the switchback by using the `metrocluster switchback` command from any node in the surviving cluster.
5. Verify that the switchback operation has completed: `metrocluster show`

The switchback operation is still running when a cluster is in the `waiting-for-switchback` state:

```

cluster_B::> metrocluster show
Cluster          Configuration State      Mode
-----
Local: cluster_B configured      switchover
Remote: cluster_A configured      waiting-for-switchback

```

The switchback operation is complete when the clusters are in the `normal` state.:

```

cluster_B::> metrocluster show
Cluster          Configuration State      Mode
-----
Local: cluster_B configured      normal
Remote: cluster_A configured      normal

```

If a switchback is taking a long time to finish, you can check on the status of in-progress baselines by using the `metrocluster config-replication resync-status show` command.

6. Reestablish any SnapMirror or SnapVault configurations.

### **Step 7: Return the failed part to NetApp**

Return the failed part to NetApp, as described in the RMA instructions shipped with the kit. See the [Part Return and Replacements](#) page for further information.

#### **Replace NVDIMM - ASA A400**

You must replace the NVDIMM in the controller module when your system registers that the flash lifetime is almost at an end or that the identified NVDIMM is not healthy in general; failure to do so causes a system panic.

All other components in the system must be functioning properly; if not, you must contact technical support.

You must replace the failed component with a replacement FRU component you received from your provider.

#### **Step 1: Shut down the impaired controller**

Shut down or take over the impaired controller using the appropriate procedure for your configuration.



## Option 1: Most configurations

To shut down the impaired controller, you must determine the status of the controller and, if necessary, take over the controller so that the healthy controller continues to serve data from the impaired controller storage.

### About this task

- If you have a SAN system, you must have checked event messages (`cluster kernel-service show`) for the impaired controller SCSI blade. The `cluster kernel-service show` command (from `priv advanced` mode) displays the node name, quorum status of that node, availability status of that node, and operational status of that node.

Each SCSI-blade process should be in quorum with the other nodes in the cluster. Any issues must be resolved before you proceed with the replacement.

- If you have a cluster with more than two nodes, it must be in quorum. If the cluster is not in quorum or a healthy controller shows false for eligibility and health, you must correct the issue before shutting down the impaired controller; see [Synchronize a node with the cluster](#).

### Steps

1. If AutoSupport is enabled, suppress automatic case creation by invoking an AutoSupport message:

```
system node autosupport invoke -node * -type all -message MAINT=<# of hours>h
```

The following AutoSupport message suppresses automatic case creation for two hours: `cluster1:>`

```
system node autosupport invoke -node * -type all -message MAINT=2h
```

2. Disable automatic giveback from the console of the healthy controller: `storage failover modify -node local -auto-giveback false`



When you see *Do you want to disable auto-giveback?*, enter *y*.

3. Take the impaired controller to the LOADER prompt:

If the impaired controller is displaying...	Then...
The LOADER prompt	Go to the next step.
Waiting for giveback...	Press Ctrl-C, and then respond <i>y</i> when prompted.
System prompt or password prompt	Take over or halt the impaired controller from the healthy controller: <code>storage failover takeover -ofnode <i>impaired_node_name</i></code>  When the impaired controller shows Waiting for giveback..., press Ctrl-C, and then respond <i>y</i> .

## Option 2: Controller is in a two-node MetroCluster

To shut down the impaired controller, you must determine the status of the controller and, if necessary,

switch over the controller so that the healthy controller continues to serve data from the impaired controller storage.

### About this task

- You must leave the power supplies turned on at the end of this procedure to provide power to the healthy controller.

### Steps

1. Check the MetroCluster status to determine whether the impaired controller has automatically switched over to the healthy controller: `metrocluster show`
2. Depending on whether an automatic switchover has occurred, proceed according to the following table:

If the impaired controller...	Then...
Has automatically switched over	Proceed to the next step.
Has not automatically switched over	Perform a planned switchover operation from the healthy controller: <code>metrocluster switchover</code>
Has not automatically switched over, you attempted switchover with the <code>metrocluster switchover</code> command, and the switchover was vetoed	Review the veto messages and, if possible, resolve the issue and try again. If you are unable to resolve the issue, contact technical support.

3. Resynchronize the data aggregates by running the `metrocluster heal -phase aggregates` command from the surviving cluster.

```
controller_A_1::> metrocluster heal -phase aggregates
[Job 130] Job succeeded: Heal Aggregates is successful.
```

If the healing is vetoed, you have the option of reissuing the `metrocluster heal` command with the `-override-vetoes` parameter. If you use this optional parameter, the system overrides any soft vetoes that prevent the healing operation.

4. Verify that the operation has been completed by using the `metrocluster operation show` command.

```
controller_A_1::> metrocluster operation show
  Operation: heal-aggregates
  State: successful
Start Time: 7/25/2016 18:45:55
End Time: 7/25/2016 18:45:56
Errors: -
```

5. Check the state of the aggregates by using the `storage aggregate show` command.

```

controller_A_1::> storage aggregate show
Aggregate      Size Available Used% State   #Vols  Nodes
RAID Status
-----
...
aggr_b2      227.1GB   227.1GB   0% online    0 mcc1-a2
raid_dp, mirrored, normal...

```

6. Heal the root aggregates by using the `metrocluster heal -phase root-aggregates` command.

```

mcc1A::> metrocluster heal -phase root-aggregates
[Job 137] Job succeeded: Heal Root Aggregates is successful

```

If the healing is vetoed, you have the option of reissuing the `metrocluster heal` command with the `-override-vetoes` parameter. If you use this optional parameter, the system overrides any soft vetoes that prevent the healing operation.

7. Verify that the heal operation is complete by using the `metrocluster operation show` command on the destination cluster:

```

mcc1A::> metrocluster operation show
Operation: heal-root-aggregates
State: successful
Start Time: 7/29/2016 20:54:41
End Time: 7/29/2016 20:54:42
Errors: -

```

8. On the impaired controller module, disconnect the power supplies.

## Step 2: Remove the controller module

To access components inside the controller module, you must remove the controller module from the chassis.

1. If you are not already grounded, properly ground yourself.
2. Release the power cable retainers, and then unplug the cables from the power supplies.
3. Loosen the hook and loop strap binding the cables to the cable management device, and then unplug the system cables and SFPs (if needed) from the controller module, keeping track of where the cables were connected.

Leave the cables in the cable management device so that when you reinstall the cable management device, the cables are organized.

4. Remove the cable management device from the controller module and set it aside.

5. Press down on both of the locking latches, and then rotate both latches downward at the same time.

The controller module moves slightly out of the chassis.

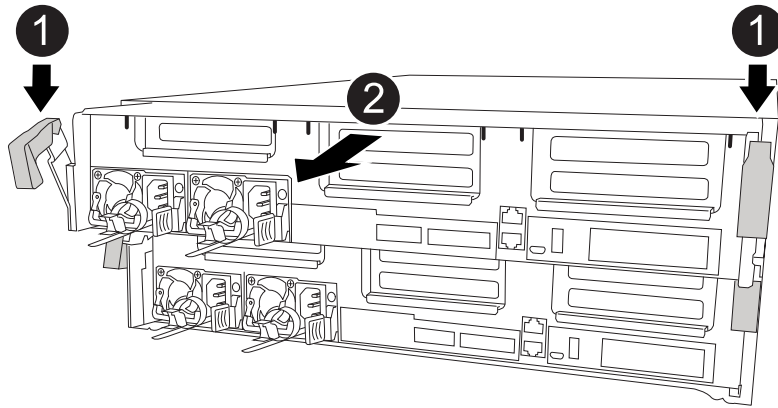

<b>1</b>	Locking latches
<b>2</b>	Controller moves slightly out of chassis

6. Slide the controller module out of the chassis.

Make sure that you support the bottom of the controller module as you slide it out of the chassis.

7. Place the controller module on a stable, flat surface.

### Step 3: Replace the NVDIMM

To replace the NVDIMM, you must locate it in the controller module using the FRU map on top of the air duct or the FRU Map on the top of the slot 1 riser.

- The NVDIMM LED blinks while destaging contents when you halt the system. After the destage is complete, the LED turns off.
- Although the contents of the NVDIMM is encrypted, it is a best practice to erase the contents of the NVDIMM before replacing it. For more information, see the [Statement of Volatility](#) on the NetApp Support Site.



You must log into the NetApp Support Site to display the *Statement of Volatility* for your system.

You can use the following animation, illustration, or the written steps to replace the NVDIMM.



The animation shows empty slots for sockets without DIMMs. These empty sockets are populated with blanks.

[Animation - Replace the NVDIMM](#)

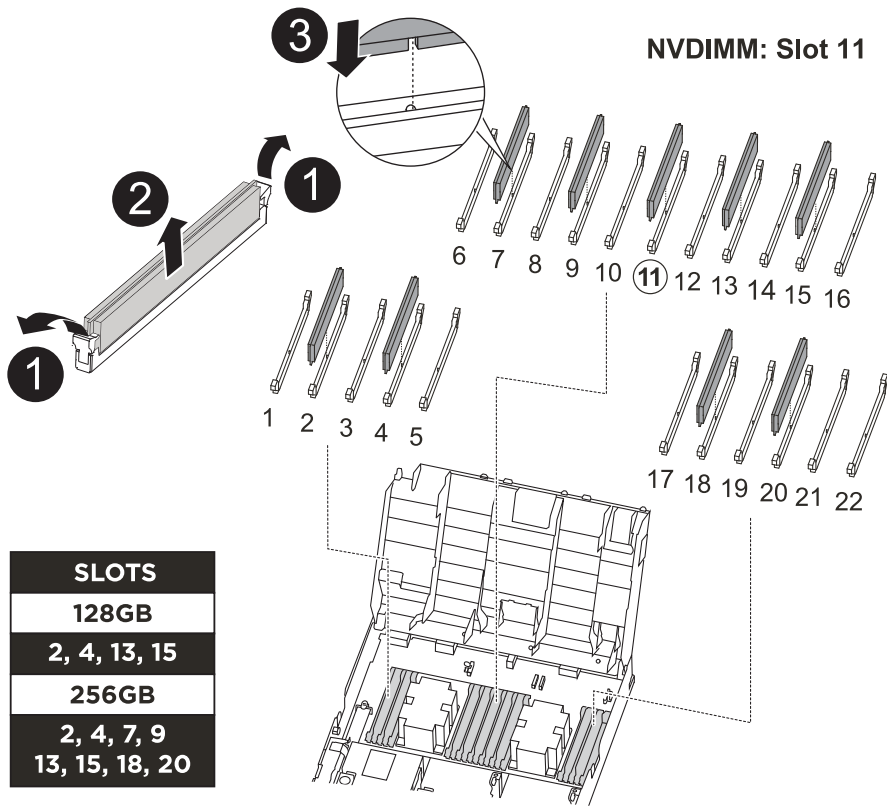

<b>1</b>	DIMM locking tabs
<b>2</b>	DIMM
<b>3</b>	DIMM socket

1. Open the air duct and then locate the NVDIMM in slot 11 on your controller module.



The NVDIMM looks significantly different than system DIMMs.

2. Eject the NVDIMM from its slot by slowly pushing apart the two NVDIMM ejector tabs on either side of the NVDIMM, and then slide the NVDIMM out of the socket and set it aside.



Carefully hold the NVDIMM by the edges to avoid pressure on the components on the NVDIMM circuit board.

3. Remove the replacement NVDIMM from the antistatic shipping bag, hold the NVDIMM by the corners, and then align it to the slot.

The notch among the pins on the NVDIMM should line up with the tab in the socket.

4. Locate the slot where you are installing the NVDIMM.

5. Insert the NVDIMM squarely into the slot.

The NVDIMM fits tightly in the slot, but should go in easily. If not, realign the NVDIMM with the slot and

reinsert it.



Visually inspect the NVDIMM to verify that it is evenly aligned and fully inserted into the slot.

6. Push carefully, but firmly, on the top edge of the NVDIMM until the ejector tabs snap into place over the notches at the ends of the NVDIMM.
7. Close the air duct.

#### Step 4: Install the controller module

After you have replaced the component in the controller module, you must reinstall the controller module into the chassis, and then boot it to Maintenance mode.

1. If you have not already done so, close the air duct.
2. Align the end of the controller module with the opening in the chassis, and then gently push the controller module halfway into the system.



Do not completely insert the controller module in the chassis until instructed to do so.

3. Cable the management and console ports only, so that you can access the system to perform the tasks in the following sections.



You will connect the rest of the cables to the controller module later in this procedure.

4. Complete the installation of the controller module:
  - a. Plug the power cord into the power supply, reinstall the power cable locking collar, and then connect the power supply to the power source.
  - b. Using the locking latches, firmly push the controller module into the chassis until the locking latches begin to rise.



Do not use excessive force when sliding the controller module into the chassis to avoid damaging the connectors.

- c. Fully seat the controller module in the chassis by rotating the locking latches upward, tilting them so that they clear the locking pins, gently push the controller all the way in, and then lower the locking latches into the locked position.

The controller module begins to boot as soon as it is fully seated in the chassis. Be prepared to interrupt the boot process.

- d. If you have not already done so, reinstall the cable management device.
- e. Interrupt the normal boot process and boot to LOADER by pressing `Ctrl-C`.



If your system stops at the boot menu, select the option to boot to LOADER.

- f. At the LOADER prompt, enter `bye` to reinitialize the PCIe cards and other components.
- g. Interrupt the boot process and boot to the LOADER prompt by pressing `Ctrl-C`.

If your system stops at the boot menu, select the option to boot to LOADER.

## Step 5: Restore the controller module to operation

You must recable the system, give back the controller module, and then reenables automatic giveback.

1. Recable the system, as needed.

If you removed the media converters (QSFPs or SFPs), remember to reinstall them if you are using fiber optic cables.

2. Return the controller to normal operation by giving back its storage: `storage failover giveback -ofnode impaired_node_name`
3. If automatic giveback was disabled, reenables it: `storage failover modify -node local -auto-giveback true`

## Step 6: Switch back aggregates in a two-node MetroCluster configuration

After you have completed the FRU replacement in a two-node MetroCluster configuration, you can perform the MetroCluster switchback operation. This returns the configuration to its normal operating state, with the sync-source storage virtual machines (SVMs) on the formerly impaired site now active and serving data from the local disk pools.

This task only applies to two-node MetroCluster configurations.

### Steps

1. Verify that all nodes are in the enabled state: `metrocluster node show`

```
cluster_B::> metrocluster node show

DR                               Configuration  DR
Group Cluster Node              State          Mirroring Mode
-----
1      cluster_A
      controller_A_1 configured      enabled      heal roots
completed
      cluster_B
      controller_B_1 configured      enabled      waiting for
switchback recovery
2 entries were displayed.
```

2. Verify that resynchronization is complete on all SVMs: `metrocluster vserver show`
3. Verify that any automatic LIF migrations being performed by the healing operations were completed successfully: `metrocluster check lif show`
4. Perform the switchback by using the `metrocluster switchback` command from any node in the surviving cluster.
5. Verify that the switchback operation has completed: `metrocluster show`

The switchback operation is still running when a cluster is in the `waiting-for-switchback` state:

```

cluster_B::> metrocluster show
Cluster           Configuration State      Mode
-----
Local: cluster_B configured      switchover
Remote: cluster_A configured     waiting-for-switchback

```

The switchback operation is complete when the clusters are in the normal state.:

```

cluster_B::> metrocluster show
Cluster           Configuration State      Mode
-----
Local: cluster_B configured      normal
Remote: cluster_A configured     normal

```

If a switchback is taking a long time to finish, you can check on the status of in-progress baselines by using the `metrocluster config-replication resync-status show` command.

6. Reestablish any SnapMirror or SnapVault configurations.

### Step 7: Return the failed part to NetApp

Return the failed part to NetApp, as described in the RMA instructions shipped with the kit. See the [Part Return and Replacements](#) page for further information.

#### Replace a PCIe or mezzanine card - ASA A400

To replace a PCIe or mezzanine card, you must disconnect the cables and any SFP and QSFP modules from the cards, replace the failed PCIe or mezzanine card, and then recable the cards.

- You can use this procedure with all versions of ONTAP supported by your system
- All other components in the system must be functioning properly; if not, you must contact technical support.

#### Step 1: Shut down the impaired controller

You can shut down or take over the impaired controller using different procedures, depending on the storage system hardware configuration.



### Option 1: Most configurations

To shut down the impaired controller, you must determine the status of the controller and, if necessary, take over the controller so that the healthy controller continues to serve data from the impaired controller storage.

#### About this task

- If you have a SAN system, you must have checked event messages (`cluster kernel-service show`) for the impaired controller SCSI blade. The `cluster kernel-service show` command (from `priv advanced` mode) displays the node name, quorum status of that node, availability status of that node, and operational status of that node.

Each SCSI-blade process should be in quorum with the other nodes in the cluster. Any issues must be resolved before you proceed with the replacement.

- If you have a cluster with more than two nodes, it must be in quorum. If the cluster is not in quorum or a healthy controller shows `false` for eligibility and health, you must correct the issue before shutting down the impaired controller; see [Synchronize a node with the cluster](#).

#### Steps

1. If AutoSupport is enabled, suppress automatic case creation by invoking an AutoSupport message:

```
system node autosupport invoke -node * -type all -message MAINT=<# of hours>h
```

The following AutoSupport message suppresses automatic case creation for two hours: `cluster1:> system node autosupport invoke -node * -type all -message MAINT=2h`

2. Disable automatic giveback from the console of the healthy controller: `storage failover modify -node local -auto-giveback false`



When you see *Do you want to disable auto-giveback?*, enter *y*.

3. Take the impaired controller to the LOADER prompt:

If the impaired controller is displaying...	Then...
The LOADER prompt	Go to the next step.
Waiting for giveback...	Press Ctrl-C, and then respond <i>y</i> when prompted.
System prompt or password prompt	Take over or halt the impaired controller from the healthy controller: <code>storage failover takeover -ofnode <i>impaired_node_name</i></code>  When the impaired controller shows <i>Waiting for giveback...</i> , press Ctrl-C, and then respond <i>y</i> .

### Option 2: Controller is in a two-node MetroCluster

To shut down the impaired controller, you must determine the status of the controller and, if necessary, switch over the controller so that the healthy controller continues to serve data from the impaired controller storage.

#### About this task

- You must leave the power supplies turned on at the end of this procedure to provide power to the healthy controller.

#### Steps

1. Check the MetroCluster status to determine whether the impaired controller has automatically switched over to the healthy controller: `metrocluster show`
2. Depending on whether an automatic switchover has occurred, proceed according to the following table:

If the impaired controller...	Then...
Has automatically switched over	Proceed to the next step.
Has not automatically switched over	Perform a planned switchover operation from the healthy controller: <code>metrocluster switchover</code>
Has not automatically switched over, you attempted switchover with the <code>metrocluster switchover</code> command, and the switchover was vetoed	Review the veto messages and, if possible, resolve the issue and try again. If you are unable to resolve the issue, contact technical support.

3. Resynchronize the data aggregates by running the `metrocluster heal -phase aggregates` command from the surviving cluster.

```
controller_A_1::> metrocluster heal -phase aggregates
[Job 130] Job succeeded: Heal Aggregates is successful.
```

If the healing is vetoed, you have the option of reissuing the `metrocluster heal` command with the `-override-vetoes` parameter. If you use this optional parameter, the system overrides any soft vetoes that prevent the healing operation.

4. Verify that the operation has been completed by using the `metrocluster operation show` command.

```
controller_A_1::> metrocluster operation show
  Operation: heal-aggregates
    State: successful
Start Time: 7/25/2016 18:45:55
End Time: 7/25/2016 18:45:56
Errors: -
```

5. Check the state of the aggregates by using the `storage aggregate show` command.

```
controller_A_1::> storage aggregate show
Aggregate      Size Available Used% State   #Vols  Nodes
RAID Status
-----
...
aggr_b2       227.1GB   227.1GB   0% online    0  mcc1-a2
raid_dp, mirrored, normal...
```

6. Heal the root aggregates by using the `metrocluster heal -phase root-aggregates` command.

```
mcc1A::> metrocluster heal -phase root-aggregates
[Job 137] Job succeeded: Heal Root Aggregates is successful
```

If the healing is vetoed, you have the option of reissuing the `metrocluster heal` command with the `-override-vetoes` parameter. If you use this optional parameter, the system overrides any soft vetoes that prevent the healing operation.

7. Verify that the heal operation is complete by using the `metrocluster operation show` command on the destination cluster:

```
mcc1A::> metrocluster operation show
Operation: heal-root-aggregates
State: successful
Start Time: 7/29/2016 20:54:41
End Time: 7/29/2016 20:54:42
Errors: -
```

8. On the impaired controller module, disconnect the power supplies.

## Step 2: Remove the controller module

To access components inside the controller module, you must remove the controller module from the chassis.

1. If you are not already grounded, properly ground yourself.
2. Release the power cable retainers, and then unplug the cables from the power supplies.
3. Loosen the hook and loop strap binding the cables to the cable management device, and then unplug the system cables and SFPs (if needed) from the controller module, keeping track of where the cables were connected.

Leave the cables in the cable management device so that when you reinstall the cable management device, the cables are organized.

4. Remove the cable management device from the controller module and set it aside.
5. Press down on both of the locking latches, and then rotate both latches downward at the same time.

The controller module moves slightly out of the chassis.

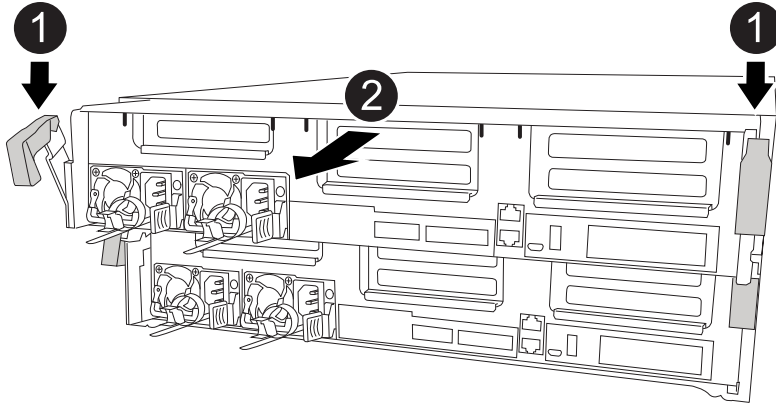

<b>1</b>	Locking latches
<b>2</b>	Controller moves slightly out of chassis

6. Slide the controller module out of the chassis.

Make sure that you support the bottom of the controller module as you slide it out of the chassis.

7. Place the controller module on a stable, flat surface.

### Step 3: Replace a PCIe card

To replace a PCIe card, you must locate the failed PCIe card, remove the riser that contains the card from the controller module, replace the card, and then reinstall the PCIe riser in the controller module.

You can use the following animation, illustration, or the written steps to replace a PCIe card.

[Animation - Replace a PCIe card](#)

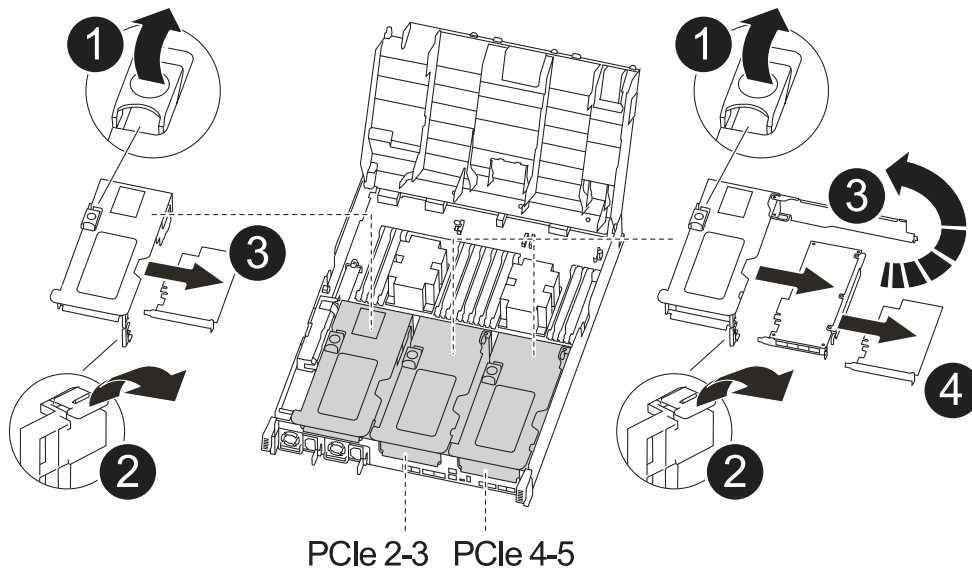

1	Riser locking latch
2	PCI card locking latch
3	PCI locking plate
4	PCI card

1. Remove the riser containing the card to be replaced:

- Open the air duct by pressing the locking tabs on the sides of the air duct, slide it toward the back of the controller module, and then rotate it to its completely open position.
- Remove any SFP or QSFP modules that might be in the PCIe cards.
- Rotate the riser locking latch on the left side of the riser up and toward air duct.

The riser raises up slightly from the controller module.

- Lift the riser up straight up and set it aside on a stable flat surface,

2. Remove the PCIe card from the riser:

- Turn the riser so that you can access the PCIe card.
- Press the locking bracket on the side of the PCIe riser, and then rotate it to the open position.
- For risers 2 and 3 only, swing the side panel up.
- Remove the PCIe card from the riser by gently pushing up on the bracket and lift the card straight out of the socket.

3. Install the replacement PCIe card in the riser by aligning the card with the socket, press the card into the socket and then close the side panel on the riser, if present.

Be sure that you properly align the card in the slot and exert even pressure on the card when seating it in the socket. The PCIe card must be fully and evenly seated in the slot.



If you are installing a card in the bottom slot and cannot see the card socket well, remove the top card so that you can see the card socket, install the card, and then reinstall the card you removed from the top slot.

4. Reinstall the riser:

- a. Align the riser with the pins to the side of the riser socket, lower the riser down on the pins.
- b. Push the riser squarely into the socket on the motherboard.
- c. Rotate the latch down flush with the sheet metal on the riser.

**Step 4: Replace the mezzanine card**

The mezzanine card is located under riser number 3 (slots 4 and 5). You must remove that riser to access the mezzanine card, replace the mezzanine card, and then reinstall riser number 3. See the FRU map on the controller module for more information.

You can use the following animation, illustration, or the written steps to replace the mezzanine card.

[Animation - Replace the mezzanine card](#)

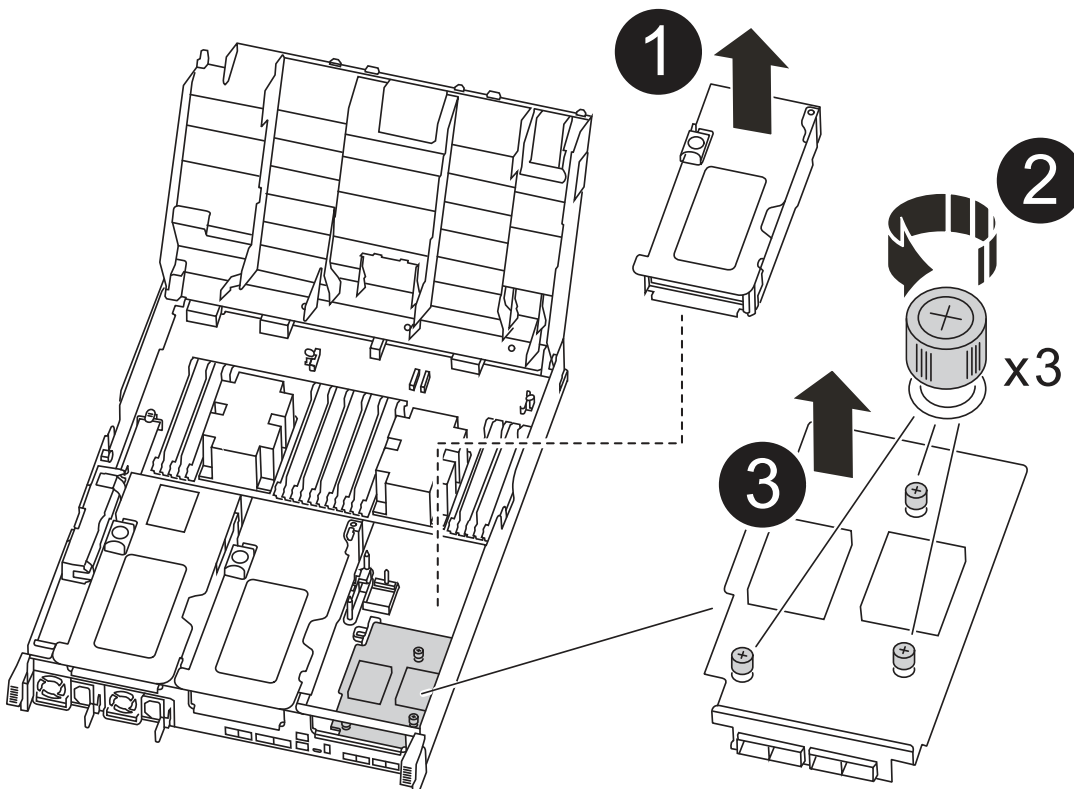

1	PCI riser
2	Riser thumbscrew

**3**

Riser card

1. Remove riser number 3 (slots 4 and 5):
  - a. Open the air duct by pressing the locking tabs on the sides of the air duct, slide it toward the back of the controller module, and then rotate it to its completely open position.
  - b. Remove any SFP or QSFP modules that might be in the PCIe cards.
  - c. Rotate the riser locking latch on the left side of the riser up and toward air duct.

The riser raises up slightly from the controller module.
  - d. Lift the riser up, and then set it aside on a stable, flat surface.
2. Replace the mezzanine card:
  - a. Remove any QSFP or SFP modules from the card.
  - b. Loosen the thumbscrews on the mezzanine card, and gently lift the card directly out of the socket and set it aside.
  - c. Align the replacement mezzanine card over the socket and the guide pins and gently push the card into the socket.
  - d. Tighten the thumbscrews on the mezzanine card.
3. Reinstall the riser:
  - a. Align the riser with the pins to the side of the riser socket, lower the riser down on the pins.
  - b. Push the riser squarely into the socket on the motherboard.
  - c. Rotate the latch down flush with the sheet metal on the riser.

### Step 5: Install the controller module

After you have replaced the component in the controller module, you must reinstall the controller module into the chassis, and then boot it to Maintenance mode.

1. If you have not already done so, close the air duct.
2. Align the end of the controller module with the opening in the chassis, and then gently push the controller module halfway into the system.



Do not completely insert the controller module in the chassis until instructed to do so.

3. Recable the system, as needed.

If you removed the media converters (QSFPs or SFPs), remember to reinstall them if you are using fiber optic cables.

4. Complete the installation of the controller module:
  - a. Plug the power cord into the power supply, reinstall the power cable locking collar, and then connect the power supply to the power source.
  - b. Using the locking latches, firmly push the controller module into the chassis until it meets the midplane and is fully seated.

The locking latches rise when the controller module is fully seated.



Do not use excessive force when sliding the controller module into the chassis to avoid damaging the connectors.

The controller module begins to boot as soon as it is fully seated in the chassis. Be prepared to interrupt the boot process.

- c. Fully seat the controller module in the chassis by rotating the locking latches upward, tilting them so that they clear the locking pins, gently push the controller all the way in, and then lower the locking latches into the locked position.
- d. If you have not already done so, reinstall the cable management device.
- e. Interrupt the normal boot process and boot to LOADER by pressing `Ctrl-C`.



If your system stops at the boot menu, select the option to boot to LOADER.

- f. At the LOADER prompt, enter `bye` to reinitialize the PCIe cards and other components and let the controller reboot.
5. Return the controller to normal operation by giving back its storage: `storage failover giveback -ofnode impaired_node_name`
  6. If automatic giveback was disabled, reenable it: `storage failover modify -node local -auto-giveback true`

## Step 6: Restore the controller module to operation

To restore the controller, you must recable the system, give back the controller module, and then reenable automatic giveback.

1. Recable the system, as needed.

If you removed the media converters (QSFPs or SFPs), remember to reinstall them if you are using fiber optic cables.

2. Return the controller to normal operation by giving back its storage: `storage failover giveback -ofnode impaired_node_name`
3. If automatic giveback was disabled, reenable it: `storage failover modify -node local -auto-giveback true`

## Step 7: Switch back aggregates in a two-node MetroCluster configuration

After you have completed the FRU replacement in a two-node MetroCluster configuration, you can perform the MetroCluster switchback operation. This returns the configuration to its normal operating state, with the sync-source storage virtual machines (SVMs) on the formerly impaired site now active and serving data from the local disk pools.

This task only applies to two-node MetroCluster configurations.

### Steps

1. Verify that all nodes are in the `enabled state`: `metrocluster node show`



```

cluster_B::> metrocluster node show

DR
Group Cluster Node          Configuration  DR
-----
-----
1      cluster_A
      controller_A_1 configured    enabled    heal roots
completed
      cluster_B
      controller_B_1 configured    enabled    waiting for
switchback recovery
2 entries were displayed.

```

2. Verify that resynchronization is complete on all SVMs: `metrocluster vserver show`
3. Verify that any automatic LIF migrations being performed by the healing operations were completed successfully: `metrocluster check lif show`
4. Perform the switchback by using the `metrocluster switchback` command from any node in the surviving cluster.
5. Verify that the switchback operation has completed: `metrocluster show`

The switchback operation is still running when a cluster is in the `waiting-for-switchback` state:

```

cluster_B::> metrocluster show
Cluster          Configuration State      Mode
-----
Local: cluster_B configured    switchover
Remote: cluster_A configured    waiting-for-switchback

```

The switchback operation is complete when the clusters are in the `normal` state.:

```

cluster_B::> metrocluster show
Cluster          Configuration State      Mode
-----
Local: cluster_B configured    normal
Remote: cluster_A configured    normal

```

If a switchback is taking a long time to finish, you can check on the status of in-progress baselines by using the `metrocluster config-replication resync-status show` command.

6. Reestablish any SnapMirror or SnapVault configurations.

## Step 8: Return the failed part to NetApp

Return the failed part to NetApp, as described in the RMA instructions shipped with the kit. See the [Part Return and Replacements](#) page for further information.

### Replacing a power supply - ASA A400

Replacing a power supply (PSU) involves disconnecting the target PSU from the power source, unplugging the power cable, removing the old PSU and installing the replacement PSU, and then reconnecting the replacement PSU to the power source.

- The power supplies are redundant and hot-swappable.
- This procedure is written for replacing one power supply at a time.



It is a best practice to replace the power supply within two minutes of removing it from the chassis. The system continues to function, but ONTAP sends messages to the console about the degraded power supply until the power supply is replaced.



Do not mix PSUs with different efficiency ratings. Always replace like for like.

You can use the following illustration with the written steps to replace the power supply.

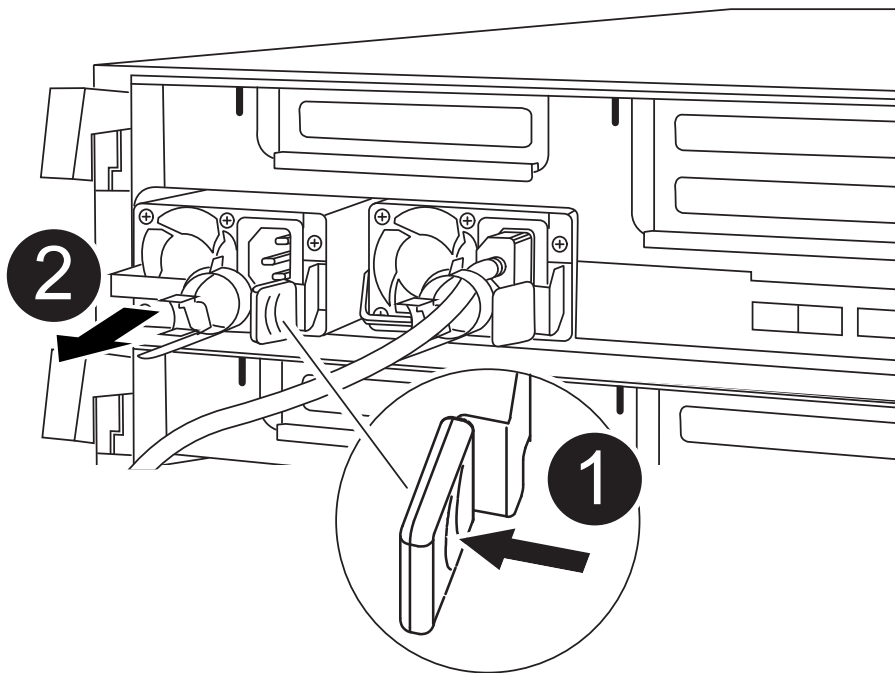

<b>1</b>	PSU locking tab
<b>2</b>	Power cable retainer

1. If you are not already grounded, properly ground yourself.

2. Identify the power supply you want to replace, based on console error messages or through the LEDs on the power supplies.
3. Disconnect the power supply:
  - a. Open the power cable retainer, and then unplug the power cable from the power supply.
  - b. Unplug the power cable from the power source.
4. Remove the power supply:
  - a. Rotate the cam handle so that it can be used to pull the power supply out of the chassis.
  - b. Press the blue locking tab to release the power supply from the chassis.
  - c. Using both hands, pull the power supply out of the chassis, and then set it aside.
5. Using both hands, support and align the edges of the power supply with the opening in the controller module, and then gently push the power supply into the controller module until the locking tab clicks into place.

The power supplies will only properly engage with the internal connector and lock in place one way.



To avoid damaging the internal connector, do not use excessive force when sliding the power supply into the system.

6. Rotate the cam handle so that it is flush against the power supply.
7. Reconnect the power supply cabling:
  - a. Reconnect the power cable to the power supply and the power source.
  - b. Secure the power cable to the power supply using the power cable retainer.

Once power is restored to the power supply, the status LED should be green.

8. Return the failed part to NetApp, as described in the RMA instructions shipped with the kit. See the [Part Return and Replacements](#) page for further information.

#### **Replace the real-time clock battery - ASA A400**

You replace the real-time clock (RTC) battery in the controller module so that your system's services and applications that depend on accurate time synchronization continue to function.

- You can use this procedure with all versions of ONTAP supported by your system
- All other components in the system must be functioning properly; if not, you must contact technical support.

#### **Step 1: Shut down the impaired controller**

You can shut down or take over the impaired controller using different procedures, depending on the storage system hardware configuration.

### Option 1: Most configurations

To shut down the impaired controller, you must determine the status of the controller and, if necessary, take over the controller so that the healthy controller continues to serve data from the impaired controller storage.

#### About this task

- If you have a SAN system, you must have checked event messages (`cluster kernel-service show`) for the impaired controller SCSI blade. The `cluster kernel-service show` command (from `priv advanced` mode) displays the node name, quorum status of that node, availability status of that node, and operational status of that node.

Each SCSI-blade process should be in quorum with the other nodes in the cluster. Any issues must be resolved before you proceed with the replacement.

- If you have a cluster with more than two nodes, it must be in quorum. If the cluster is not in quorum or a healthy controller shows false for eligibility and health, you must correct the issue before shutting down the impaired controller; see [Synchronize a node with the cluster](#).

#### Steps

1. If AutoSupport is enabled, suppress automatic case creation by invoking an AutoSupport message:

```
system node autosupport invoke -node * -type all -message MAINT=<# of hours>h
```

The following AutoSupport message suppresses automatic case creation for two hours: `cluster1:>`

```
system node autosupport invoke -node * -type all -message MAINT=2h
```

2. Disable automatic giveback from the console of the healthy controller: `storage failover modify -node local -auto-giveback false`



When you see *Do you want to disable auto-giveback?*, enter *y*.

3. Take the impaired controller to the LOADER prompt:

If the impaired controller is displaying...	Then...
The LOADER prompt	Go to the next step.
Waiting for giveback...	Press Ctrl-C, and then respond <i>y</i> when prompted.
System prompt or password prompt	Take over or halt the impaired controller from the healthy controller: <code>storage failover takeover -ofnode <i>impaired_node_name</i></code>  When the impaired controller shows Waiting for giveback..., press Ctrl-C, and then respond <i>y</i> .

### Option 2: Controller is in a two-node MetroCluster

To shut down the impaired controller, you must determine the status of the controller and, if necessary,

switch over the controller so that the healthy controller continues to serve data from the impaired controller storage.

### About this task

- You must leave the power supplies turned on at the end of this procedure to provide power to the healthy controller.

### Steps

1. Check the MetroCluster status to determine whether the impaired controller has automatically switched over to the healthy controller: `metrocluster show`
2. Depending on whether an automatic switchover has occurred, proceed according to the following table:

If the impaired controller...	Then...
Has automatically switched over	Proceed to the next step.
Has not automatically switched over	Perform a planned switchover operation from the healthy controller: <code>metrocluster switchover</code>
Has not automatically switched over, you attempted switchover with the <code>metrocluster switchover</code> command, and the switchover was vetoed	Review the veto messages and, if possible, resolve the issue and try again. If you are unable to resolve the issue, contact technical support.

3. Resynchronize the data aggregates by running the `metrocluster heal -phase aggregates` command from the surviving cluster.

```
controller_A_1::> metrocluster heal -phase aggregates
[Job 130] Job succeeded: Heal Aggregates is successful.
```

If the healing is vetoed, you have the option of reissuing the `metrocluster heal` command with the `-override-vetoes` parameter. If you use this optional parameter, the system overrides any soft vetoes that prevent the healing operation.

4. Verify that the operation has been completed by using the `metrocluster operation show` command.

```
controller_A_1::> metrocluster operation show
  Operation: heal-aggregates
  State: successful
Start Time: 7/25/2016 18:45:55
End Time: 7/25/2016 18:45:56
Errors: -
```

5. Check the state of the aggregates by using the `storage aggregate show` command.

```

controller_A_1::> storage aggregate show
Aggregate      Size Available Used% State   #Vols  Nodes
RAID Status
-----
...
aggr_b2       227.1GB   227.1GB   0% online    0 mcc1-a2
raid_dp, mirrored, normal...

```

6. Heal the root aggregates by using the `metrocluster heal -phase root-aggregates` command.

```

mcc1A::> metrocluster heal -phase root-aggregates
[Job 137] Job succeeded: Heal Root Aggregates is successful

```

If the healing is vetoed, you have the option of reissuing the `metrocluster heal` command with the `-override-vetoes` parameter. If you use this optional parameter, the system overrides any soft vetoes that prevent the healing operation.

7. Verify that the heal operation is complete by using the `metrocluster operation show` command on the destination cluster:

```

mcc1A::> metrocluster operation show
Operation: heal-root-aggregates
State: successful
Start Time: 7/29/2016 20:54:41
End Time: 7/29/2016 20:54:42
Errors: -

```

8. On the impaired controller module, disconnect the power supplies.

## Step 2: Remove the controller module

To access components inside the controller module, you must remove the controller module from the chassis.

1. If you are not already grounded, properly ground yourself.
2. Release the power cable retainers, and then unplug the cables from the power supplies.
3. Loosen the hook and loop strap binding the cables to the cable management device, and then unplug the system cables and SFPs (if needed) from the controller module, keeping track of where the cables were connected.

Leave the cables in the cable management device so that when you reinstall the cable management device, the cables are organized.

4. Remove the cable management device from the controller module and set it aside.

5. Press down on both of the locking latches, and then rotate both latches downward at the same time.

The controller module moves slightly out of the chassis.

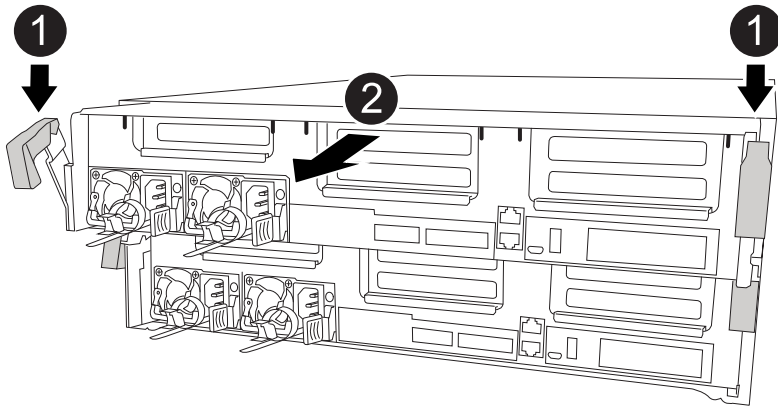

<b>1</b>	Locking latches
<b>2</b>	Controller moves slightly out of chassis

6. Slide the controller module out of the chassis.

Make sure that you support the bottom of the controller module as you slide it out of the chassis.

7. Place the controller module on a stable, flat surface.

### Step 3: Replace the RTC battery

You need to locate the RTC battery inside the controller module, and then follow the specific sequence of steps. See the FRU map inside the controller module for the location of the RTC battery.

You can use the following animation, illustration, or the written steps to replace the RTC battery.

#### Animation- Replace the RTC battery

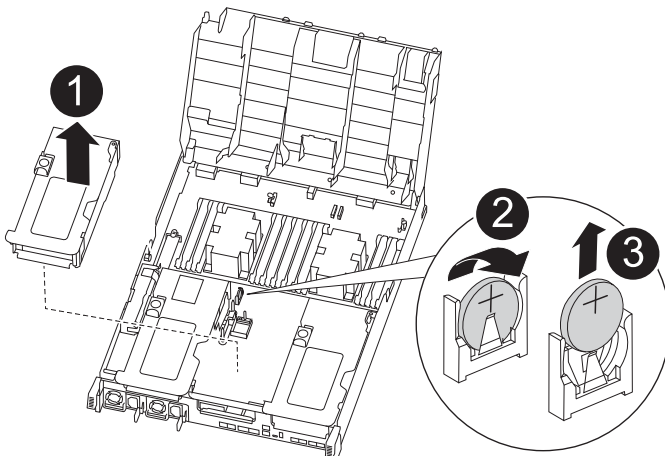

<b>1</b>	Middle riser
<b>2</b>	Remove RTC battery
<b>3</b>	Seat RTC battery

1. If you are not already grounded, properly ground yourself.
2. Open the air duct:
  - a. Press the locking tabs on the sides of the air duct in toward the middle of the controller module.
  - b. Slide the air duct toward the back of the controller module, and then rotate it upward to its completely open position.
3. Locate, remove, and then replace the RTC battery:
  - a. Using the FRU map, locate the RTC battery on the controller module.
  - b. Gently push the battery away from the holder, rotate it away from the holder, and then lift it out of the holder.



Note the polarity of the battery as you remove it from the holder. The battery is marked with a plus sign and must be positioned in the holder correctly. A plus sign near the holder tells you how the battery should be positioned.

- c. Remove the replacement battery from the antistatic shipping bag.
  - d. Note the polarity of the RTC battery, and then insert it into the holder by tilting the battery at an angle and pushing down.
4. Visually inspect the battery to make sure that it is completely installed into the holder and that the polarity is correct.
5. Close the air duct.

#### **Step 4: Reinstall the controller module and setting time/date after RTC battery replacement**

After you replace a component within the controller module, you must reinstall the controller module in the system chassis, reset the time and date on the controller, and then boot it.

1. If you have not already done so, close the air duct or controller module cover.
2. Align the end of the controller module with the opening in the chassis, and then gently push the controller module halfway into the system.

Do not completely insert the controller module in the chassis until instructed to do so.

3. Recable the system, as needed.

If you removed the media converters (QSFPs or SFPs), remember to reinstall them if you are using fiber optic cables.

4. If the power supplies were unplugged, plug them back in and reinstall the power cable retainers.
5. Complete the installation of the controller module:



- a. Using the locking latches, firmly push the controller module into the chassis until it meets the midplane and is fully seated.

The locking latches rise when the controller module is fully seated.



Do not use excessive force when sliding the controller module into the chassis to avoid damaging the connectors.

The controller module begins to boot as soon as it is fully seated in the chassis. Be prepared to interrupt the boot process.

- b. Fully seat the controller module in the chassis by rotating the locking latches upward, tilting them so that they clear the locking pins, gently push the controller all the way in, and then lower the locking latches into the locked position.
- c. If you have not already done so, reinstall the cable management device.
- d. Interrupt the normal boot process and boot to LOADER by pressing `Ctrl-C`.



If your system stops at the boot menu, select the option to boot to LOADER.

6. Reset the time and date on the controller:

- a. Check the date and time on the healthy controller with the `show date` command.
- b. At the LOADER prompt on the target controller, check the time and date.
- c. If necessary, modify the date with the `set date mm/dd/yyyy` command.
- d. If necessary, set the time, in GMT, using the `set time hh:mm:ss` command.
- e. Confirm the date and time on the target controller.

7. At the LOADER prompt, enter `bye` to reinitialize the PCIe cards and other components and let the controller reboot.

8. Return the controller to normal operation by giving back its storage: `storage failover giveback -ofnode impaired_node_name`

9. If automatic giveback was disabled, reenable it: `storage failover modify -node local -auto-giveback true`

### Step 5: Switch back aggregates in a two-node MetroCluster configuration

After you have completed the FRU replacement in a two-node MetroCluster configuration, you can perform the MetroCluster switchback operation. This returns the configuration to its normal operating state, with the sync-source storage virtual machines (SVMs) on the formerly impaired site now active and serving data from the local disk pools.

This task only applies to two-node MetroCluster configurations.

#### Steps

1. Verify that all nodes are in the `enabled` state: `metrocluster node show`

```

cluster_B::> metrocluster node show

DR                               Configuration  DR
Group Cluster Node              State          Mirroring Mode
-----
1      cluster_A
      controller_A_1 configured      enabled      heal roots
completed
      cluster_B
      controller_B_1 configured      enabled      waiting for
switchback recovery
2 entries were displayed.

```

2. Verify that resynchronization is complete on all SVMs: `metrocluster vserver show`
3. Verify that any automatic LIF migrations being performed by the healing operations were completed successfully: `metrocluster check lif show`
4. Perform the switchback by using the `metrocluster switchback` command from any node in the surviving cluster.
5. Verify that the switchback operation has completed: `metrocluster show`

The switchback operation is still running when a cluster is in the `waiting-for-switchback` state:

```

cluster_B::> metrocluster show
Cluster              Configuration State      Mode
-----
Local: cluster_B configured      switchover
Remote: cluster_A configured      waiting-for-switchback

```

The switchback operation is complete when the clusters are in the `normal` state.:

```

cluster_B::> metrocluster show
Cluster              Configuration State      Mode
-----
Local: cluster_B configured      normal
Remote: cluster_A configured      normal

```

If a switchback is taking a long time to finish, you can check on the status of in-progress baselines by using the `metrocluster config-replication resync-status show` command.

6. Reestablish any SnapMirror or SnapVault configurations.

## Step 6: Return the failed part to NetApp

Return the failed part to NetApp, as described in the RMA instructions shipped with the kit. See the [Part Return and Replacements](#) page for further information.

## ASA A800 systems

### Install and setup

**Start here: Choose your installation and setup experience**

For most configurations (including ASA configurations), you can choose from different content formats.

- [Quick steps](#)

A printable PDF of step-by-step instructions with live links to additional content.

- [Video steps](#)

Video step-by-step instructions.

- [Detailed steps](#)

Online step-by-step instructions with live links to additional content.

If your system is in a MetroCluster IP configuration, see the [Install MetroCluster IP Configuration](#) instructions.

#### Quick steps - ASA A800

This page gives graphic instructions for a typical installation of your system from racking and cabling, through initial system bring-up. Use the [AFF A800 Installation and Setup Instructions](#) if you are familiar with installing NetApp systems.



The ASA A800 uses the same installation procedure as the AFF A800 system.

#### Video steps - ASA A800

The following video shows how to install and cable your new system.

["Animation - Installation and Setup of an AFF A800"](#)



The ASA A800 uses the same installation procedure as the AFF A800 system.

#### Detailed steps - ASA A800

This page gives detailed step-by-step instructions for installing an ASA A800 system.

### Step 1: Prepare for installation

To install your system, you need to create an account and register the system. You also need to inventory the appropriate number and type of cables for your system and collect specific network information.

You need to have access to the [NetApp Hardware Universe](#) (HWU) for information about site requirements as well as additional information on your configured system. You might also want to have access to the [Release Notes for your version of ONTAP](#) for more information about this system.

### What you need

You need to provide the following at your site:

- Rack space for the storage system
- Phillips #2 screwdriver
- Additional networking cables to connect your system to your network switch and laptop or console with a Web browser
  1. Unpack the contents of all boxes.
  2. Record the system serial number from the controllers.







### Steps

1. Set up your account:
  - a. Log in to your existing account or create an account.
  - b. Register ([NetApp Product Registration](#)) your system.
2. Download and install [NetApp Downloads: Config Advisor](#) on your laptop.
3. Inventory and make a note of the number and types of cables you received.

The following table identifies the types of cables you might receive. If you receive a cable not listed in the table, see the [NetApp Hardware Universe](#) to locate the cable and identify its use.

Connector type	Part number and length	Type of cable...	For...
100 GbE cable	X66211A-05 (112-00595), 0.5m		HA interconnect
	X66211A-05 (112-00595), 0.5m; X66211-1 (112-00573), 1m		Cluster interconnect network
	X66211-2 (112-00574), 2m; X66211-5 (112-00576), 5m		Storage, Data
10 GbE cable	X6566B-3-R6 (112-00300), 3m; X6566B-5-R6 (112-00301), 5m		Data
	25 GbE cable	X66240A-2 (112-00598), 2m; X66240A-5 (112-00600), 5m	Data

Connector type	Part number and length	Type of cable...	For...
RJ-45 (order dependent)	Not applicable		Management
Fibre Channel	X66250-2 (112-00342) 2m; X66250-5 (112-00344) 5m; X66250-15 (112-00346) 15m; X66250-30 (112-00347) 30m		
Micro-USB console cable	Not applicable		Console connection during software setup
Power cables	Not applicable		Powering up the system

- Download and complete the [Cluster Configuration Worksheet](#).

## Step 2: Install the hardware

You need to install your system in a 4-post rack or NetApp system cabinet, as applicable.

### Steps

- Install the rail kits, as needed.

#### [Installing SuperRail into a four-post rack](#)

- Install and secure your system using the instructions included with the rail kit.



You need to be aware of the safety concerns associated with the weight of the system.

24 SSDs



48 SSDs



- Attach cable management devices (as shown).

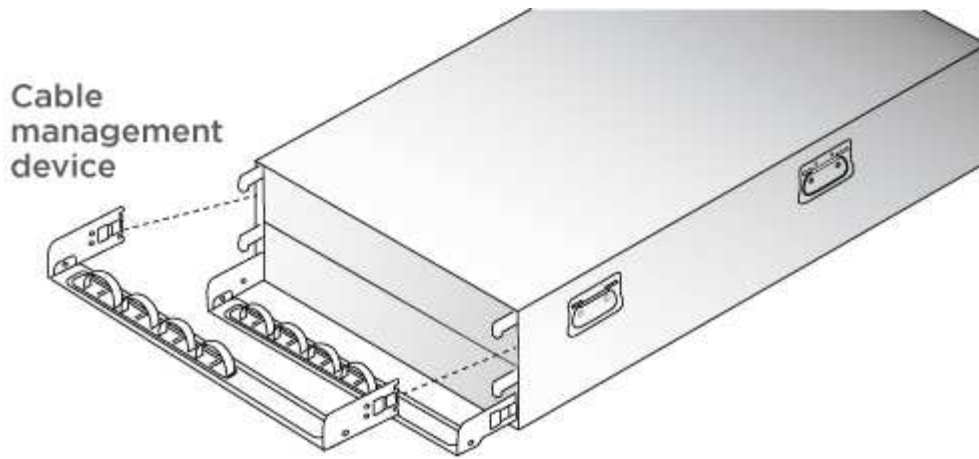

4. Place the bezel on the front of the system.

### Step 3: Cable controllers

There is required cabling for your platform's cluster using the two-node switchless cluster method or the cluster interconnect network method. There is optional cabling to the Fibre Channel or iSCSI host networks or direct-attached storage. This cabling is not exclusive; you can have cable to a host network and storage.

#### Required cabling: Cable controllers to a cluster

Cable the controllers to a cluster by using the two-node switchless cluster method or by using the cluster interconnect network.

#### Option 1: Cable a two-node switchless cluster

Management network ports on the controllers are connected to switches. The HA interconnect and cluster interconnect ports are cabled on both controllers.

#### Before you begin

Contact your network administrator for information about connecting the system to the switches.

Be sure to check the illustration arrow for the proper cable connector pull-tab orientation.

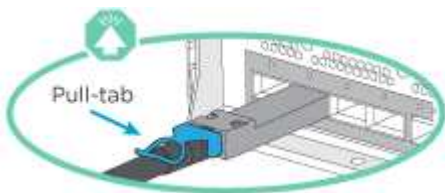

As you insert the connector, you should feel it click into place; if you do not feel it click, remove it, turn it around and try again.

#### Steps

1. Use the animation or the tabulated steps to complete the cabling between the controllers and the switches:

[Animation - Cable a two-node switchless cluster](#)

**Step** Perform on each controller module

**1**

Cable the HA interconnect ports:

- e0b to e0b
- e1b to e1b

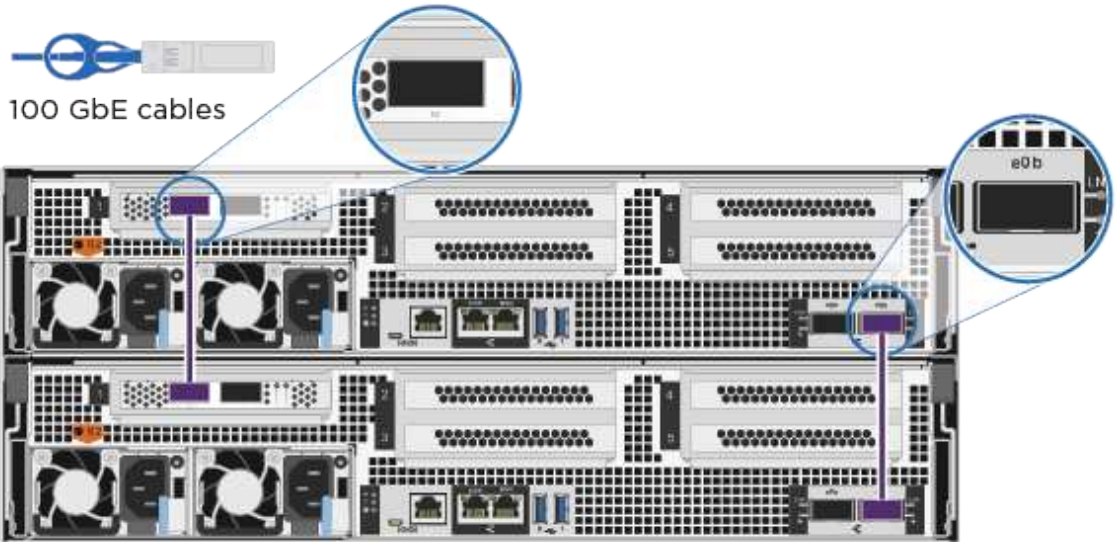



**2**

Cable the cluster interconnect ports:

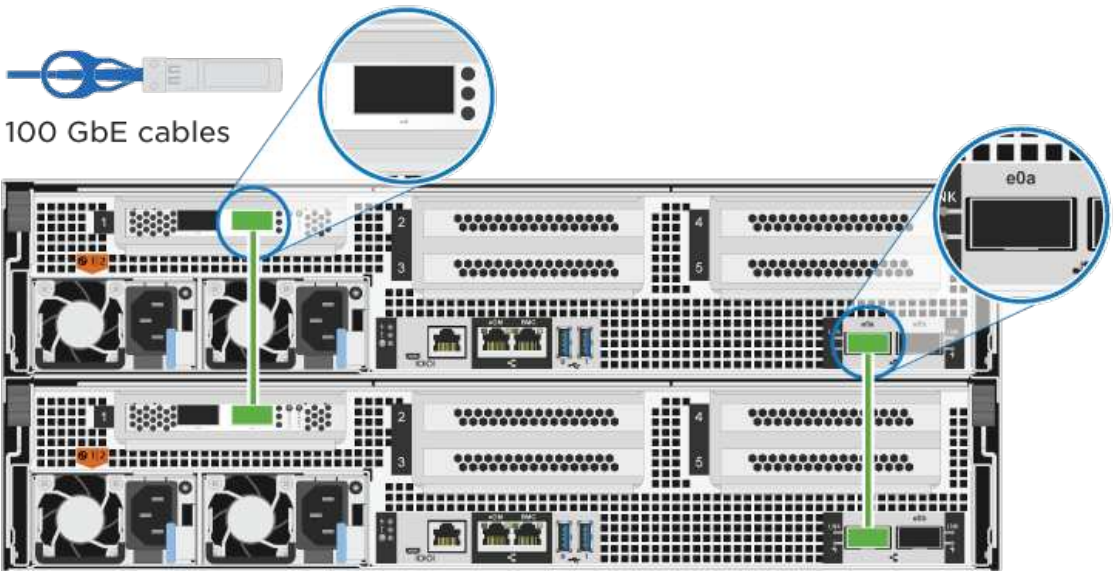
- e0a to e0a
- e1a to e1a

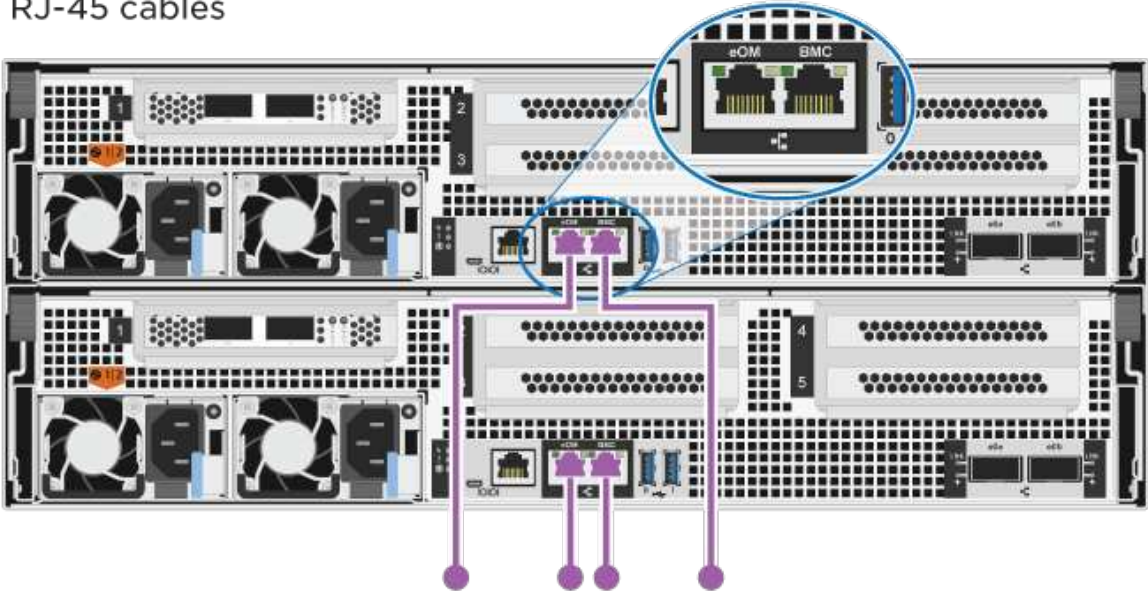

<b>Step</b>	<b>Perform on each controller module</b>
<b>3</b>	<p>Cable the management ports to the management network switches</p> <p> RJ-45 cables</p> 
	DO NOT plug in the power cords at this point.

2. To perform optional cabling, see:

- [Option 1: Cable to a Fibre Channel host network](#)
- [Option 2: Cable to a 10GbE host network](#)
- [Option 3: Cable the controllers to a single drive shelf](#)
- [Option 4: Cable the controllers to two drive shelves](#)

3. To complete setting up your system, see [Step 4: Complete system setup and configuration](#).

### Option 2: Cable a switched cluster

Cluster interconnect and management network ports on the controllers are connected to switches while the HA interconnect ports are cabled on both controllers.

#### Before you begin

Contact your network administrator for information about connecting the system to the switches.

Be sure to check the illustration arrow for the proper cable connector pull-tab orientation.

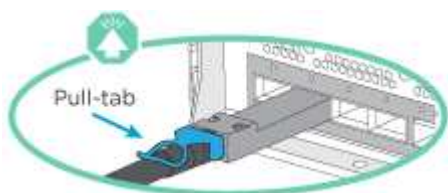





As you insert the connector, you should feel it click into place; if you do not feel it click, remove it, turn it around and try again.

## Steps

1. Use the animation or the tabulated steps to complete the cabling between the controllers and the switches:

### Animation - Cable a switched cluster

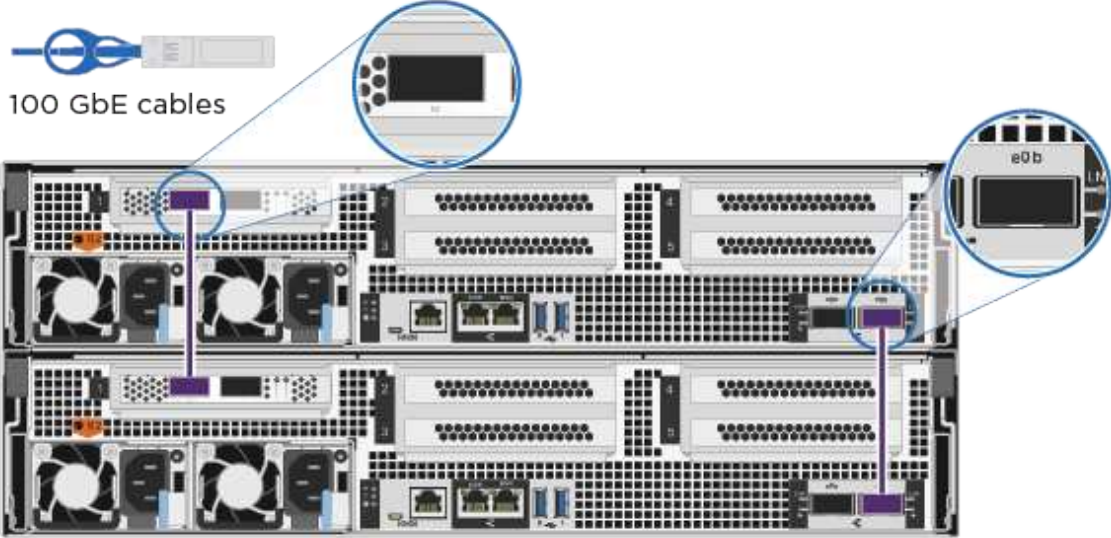
Step	Perform on each controller module
<b>1</b>	<p>Cable the HA interconnect ports:</p> <ul style="list-style-type: none"><li>• e0b to e0b</li><li>• e1b to e1b</li></ul>  <p>100 GbE cables</p>

**Step** Perform on each controller module

**2**

Cable the cluster interconnect ports to the 100 GbE cluster interconnect switches.

e0a

e1a

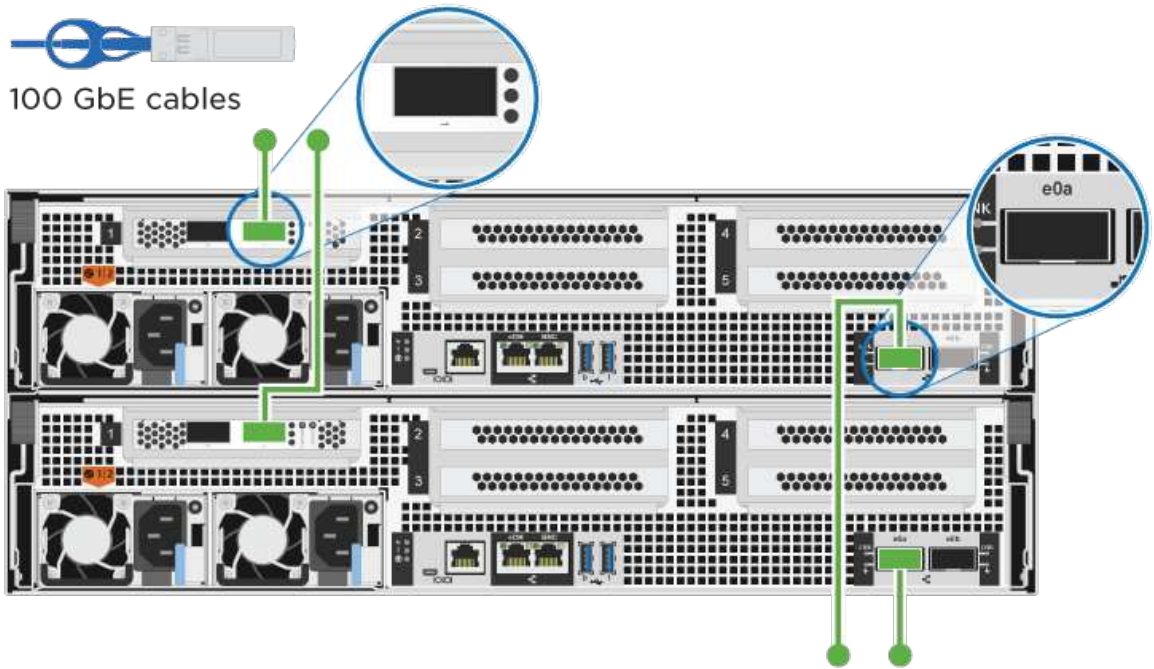

**3**

Cable the management ports to the management network switches

RJ-45 cables

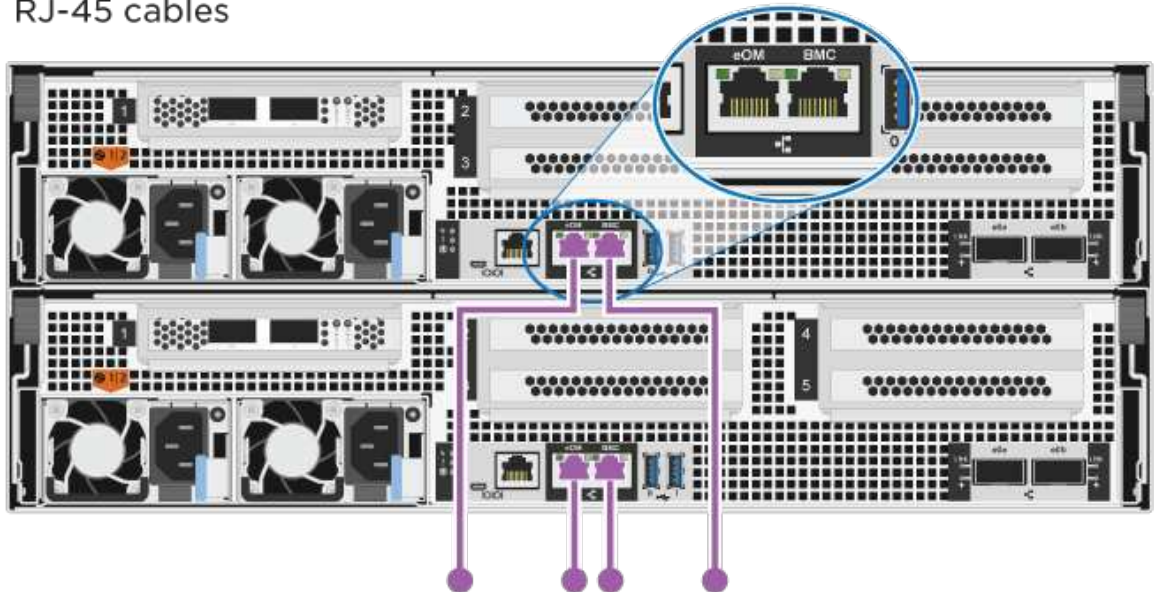

DO NOT plug in the power cords at this point.

2. To perform optional cabling, see:

- [Option 1: Cable to a Fibre Channel host network](#)
- [Option 2: Cable to a 10GbE host network](#)
- [Option 3: Cable the controllers to a single drive shelf](#)
- [Option 4: Cable the controllers to two drive shelves](#)

3. To complete setting up your system, see [Step 4: Complete system setup and configuration](#).

### Optional cabling: Cable configuration-dependent options

You have configuration-dependent optional cabling to the Fibre Channel or iSCSI host networks or direct-attached storage. This cabling is not exclusive; you can have cabling to a host network and storage.

#### Option 1: Cable to a Fibre Channel host network

Fibre Channel ports on the controllers are connected to Fibre Channel host network switches.

##### Before you begin

Contact your network administrator for information about connecting the system to the switches.

Be sure to check the illustration arrow for the proper cable connector pull-tab orientation.

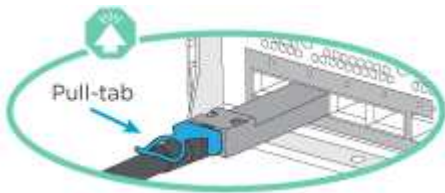

As you insert the connector, you should feel it click into place; if you do not feel it click, remove it, turn it around and try again.

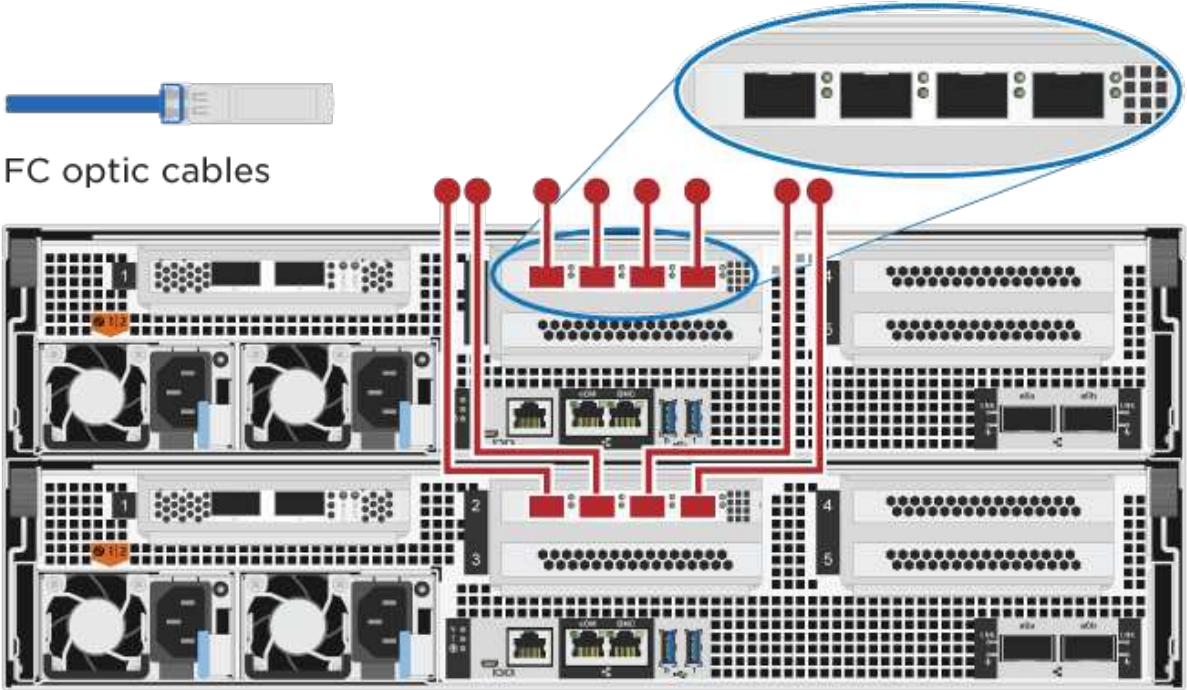
Step	Perform on each controller module
1	<p data-bbox="269 159 781 222">Cable ports 2a through 2d to the FC host switches.</p> 
2	<p data-bbox="269 999 854 1031">To perform other optional cabling, choose from:</p> <ul data-bbox="293 1062 967 1146" style="list-style-type: none"> <li data-bbox="293 1062 967 1094">• <a href="#">Option 3: Cable the controllers to a single drive shelf</a></li> <li data-bbox="293 1104 967 1136">• <a href="#">Option 4: Cable the controllers to two drive shelves</a></li> </ul>
3	<p data-bbox="269 1199 1390 1230">To complete setting up your system, see <a href="#">Step 4: Complete system setup and configuration</a>.</p>

**Option 2: Cable to a 10GbE host network**

10GbE ports on the controllers are connected to 10GbE host network switches.

**Before you begin**

Contact your network administrator for information about connecting the system to the switches.

Be sure to check the illustration arrow for the proper cable connector pull-tab orientation.

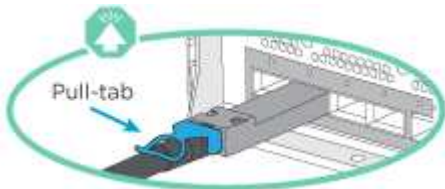

As you insert the connector, you should feel it click into place; if you do not feel it click, remove it, turn it around and try again.

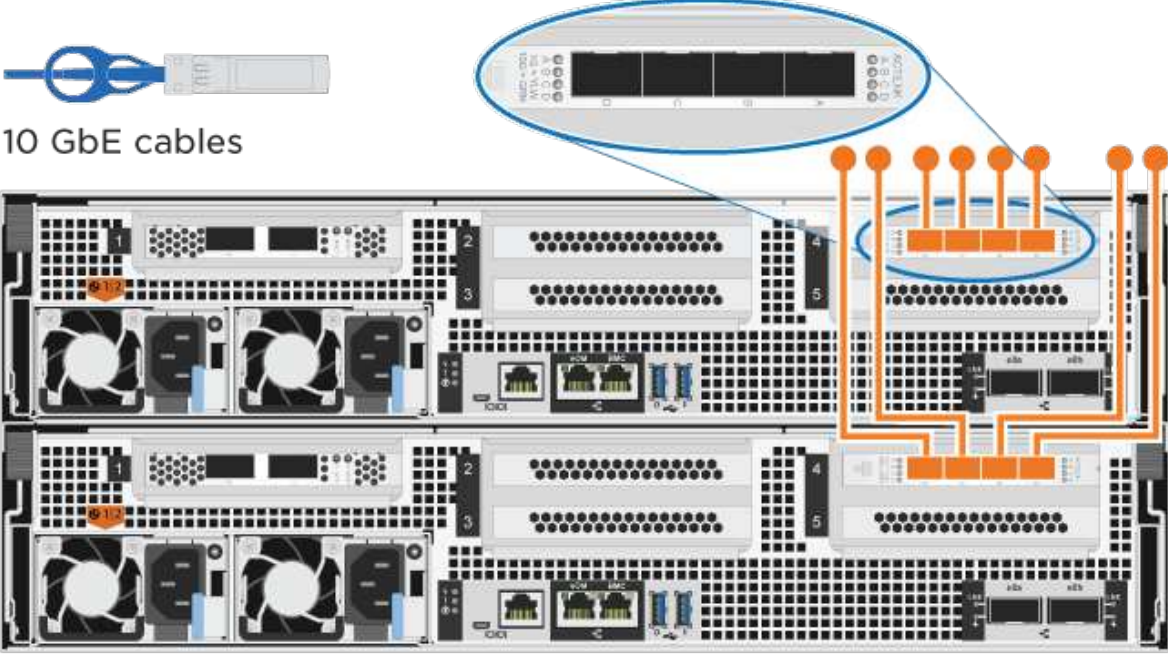
Step	Perform on each controller module
1	<p data-bbox="269 157 966 220">Cable ports e4a through e4d to the 10GbE host network switches.</p>  <p data-bbox="300 388 544 430">10 GbE cables</p>
2	<p data-bbox="269 987 852 1018">To perform other optional cabling, choose from:</p> <ul data-bbox="300 1050 966 1134" style="list-style-type: none"> <li data-bbox="300 1050 966 1081">• <a href="#">Option 3: Cable the controllers to a single drive shelf</a></li> <li data-bbox="300 1092 966 1134">• <a href="#">Option 4: Cable the controllers to two drive shelves</a></li> </ul>
3	<p data-bbox="269 1186 1388 1218">To complete setting up your system, see <a href="#">Step 4: Complete system setup and configuration</a>.</p>

### Option 3: Cable the controllers to a single drive shelf

You must cable each controller to the NSM modules on the NS224 drive shelf.

#### Before you begin

Be sure to check the illustration arrow for the proper cable connector pull-tab orientation.

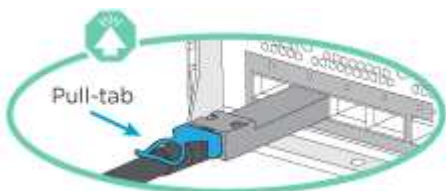

As you insert the connector, you should feel it click into place; if you do not feel it click, remove it, turn it around and try again.

Use the animation or the tabulated steps to cable your controllers to a single shelf:

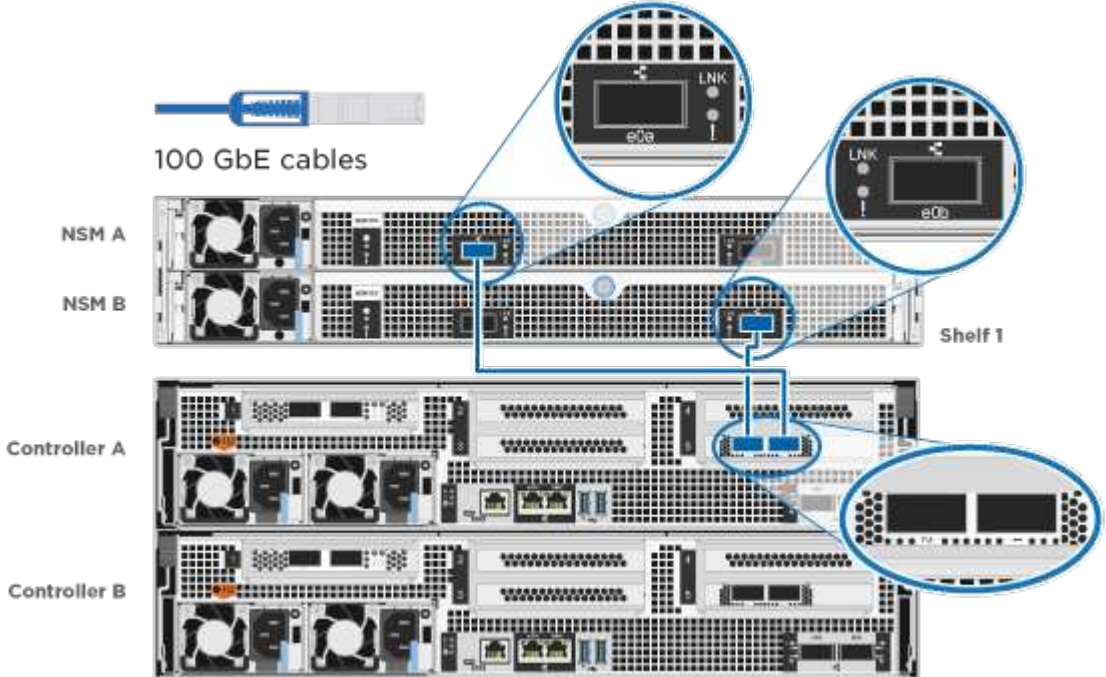
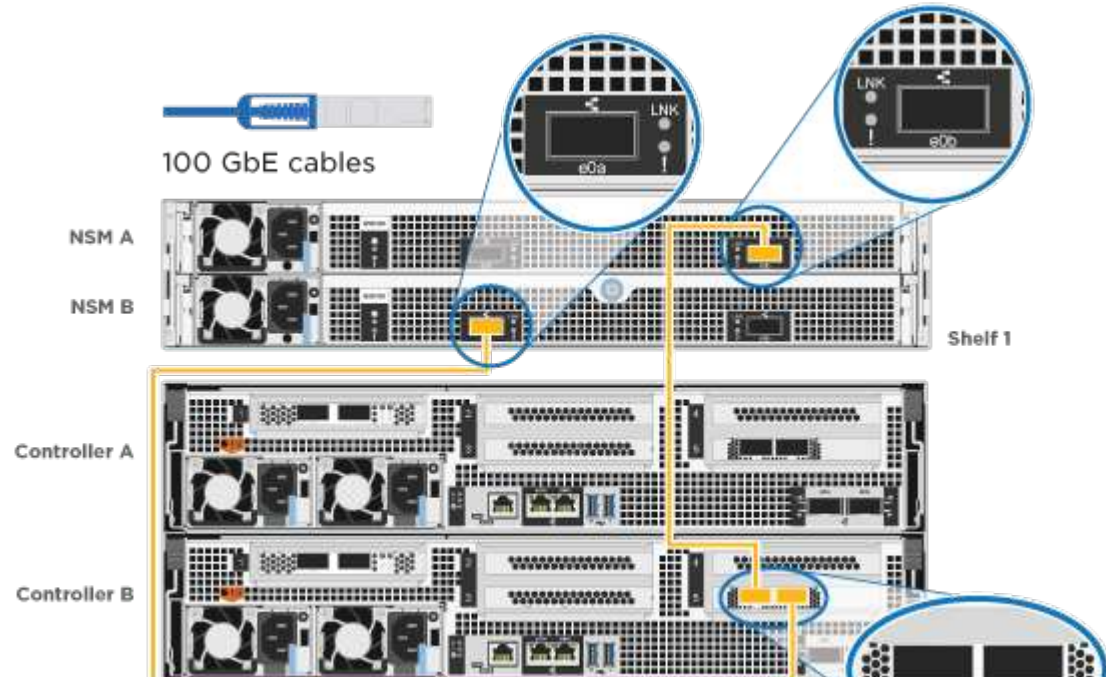
Step	Perform on each controller module
<p><b>1</b></p>	<p>Cable controller A to the shelf:</p>  <p>The diagram illustrates the connection of Controller A to Shelf 1. At the top, a blue 100 GbE cable is shown. Below it, Shelf 1 contains two Network Service Modules (NSM A and NSM B). Two blue cables are connected to the LNK and e0a ports on Shelf 1. These cables run down to Controller A, where they are plugged into the corresponding ports. Callouts provide a closer look at the LNK and e0a ports on both the shelf and Controller A. A detailed view of the ports on Controller A is also shown at the bottom right.</p>
<p><b>2</b></p>	<p>Cable controller B to the shelf:</p>  <p>The diagram illustrates the connection of Controller B to Shelf 1. At the top, a yellow 100 GbE cable is shown. Below it, Shelf 1 contains two Network Service Modules (NSM A and NSM B). Two yellow cables are connected to the LNK and e0a ports on Shelf 1. These cables run down to Controller B, where they are plugged into the corresponding ports. Callouts provide a closer look at the LNK and e0a ports on both the shelf and Controller B. A detailed view of the ports on Controller B is also shown at the bottom right.</p>

To complete setting up your system, see [Step 4: Complete system setup and configuration](#).

#### Option 4: Cable the controllers to two drive shelves

You must cable each controller to the NSM modules on both NS224 drive shelves.

#### Before you begin

Be sure to check the illustration arrow for the proper cable connector pull-tab orientation.

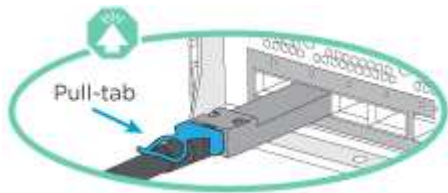

As you insert the connector, you should feel it click into place; if you do not feel it click, remove it, turn it around and try again.

Use the animation or the tabulated steps to cable your controllers to two drive shelves:

[Animation - Cable the controllers to two drive shelves](#)

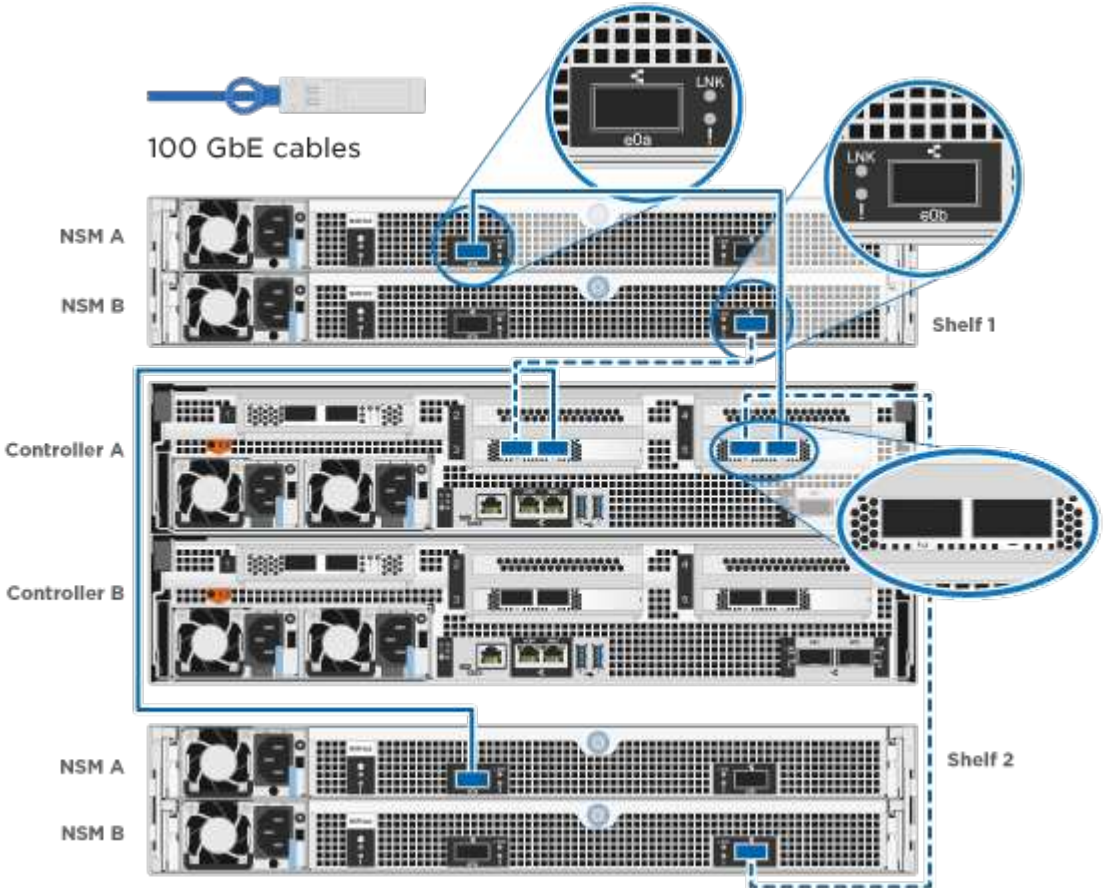
Step	Perform on each controller module
<b>1</b>	<p data-bbox="272 867 678 898">Cable controller A to the shelves:</p>  <p data-bbox="430 1035 641 1066">100 GbE cables</p> <p data-bbox="341 1129 406 1161">NSM A</p> <p data-bbox="341 1192 406 1224">NSM B</p> <p data-bbox="1209 1213 1274 1245">Shelf 1</p> <p data-bbox="284 1339 406 1371">Controller A</p> <p data-bbox="284 1486 406 1518">Controller B</p> <p data-bbox="341 1654 406 1686">NSM A</p> <p data-bbox="341 1717 406 1749">NSM B</p> <p data-bbox="1226 1654 1291 1686">Shelf 2</p>

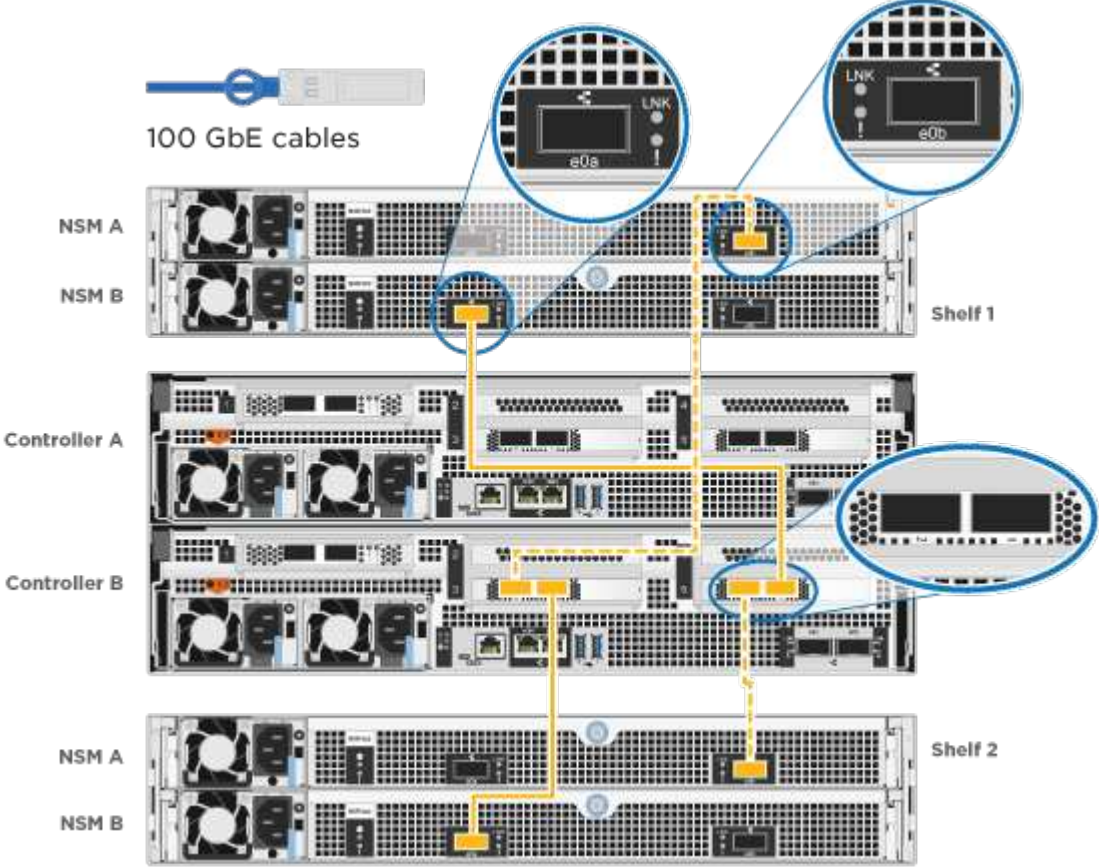
Step	Perform on each controller module
<p data-bbox="131 153 196 195">2</p>	<p data-bbox="269 153 683 195">Cable controller B to the shelves:</p>  <p data-bbox="427 321 643 363">100 GbE cables</p> <p data-bbox="342 422 407 443">NSM A</p> <p data-bbox="342 489 407 510">NSM B</p> <p data-bbox="1208 506 1273 527">Shelf 1</p> <p data-bbox="285 632 407 653">Controller A</p> <p data-bbox="285 768 407 789">Controller B</p> <p data-bbox="342 947 407 968">NSM A</p> <p data-bbox="342 1014 407 1035">NSM B</p> <p data-bbox="1208 936 1273 957">Shelf 2</p>

To complete setting up your system, see [Step 4: Complete system setup and configuration](#).

#### Step 4: Complete system setup and configuration

Complete the system setup and configuration using cluster discovery with only a connection to the switch and laptop, or by connecting directly to a controller in the system and then connecting to the management switch.

##### Option 1: Complete system setup and configuration if network discovery is enabled

If you have network discovery enabled on your laptop, you can complete system setup and configuration using automatic cluster discovery.

##### Steps

1. Plug the power cords into the controller power supplies, and then connect them to power sources on different circuits.

The system begins to boot. Initial booting may take up to eight minutes.

2. Make sure that your laptop has network discovery enabled.

See your laptop's online help for more information.

3. Use the animation to connect your laptop to the Management switch:



4. Select an ONTAP icon listed to discover:

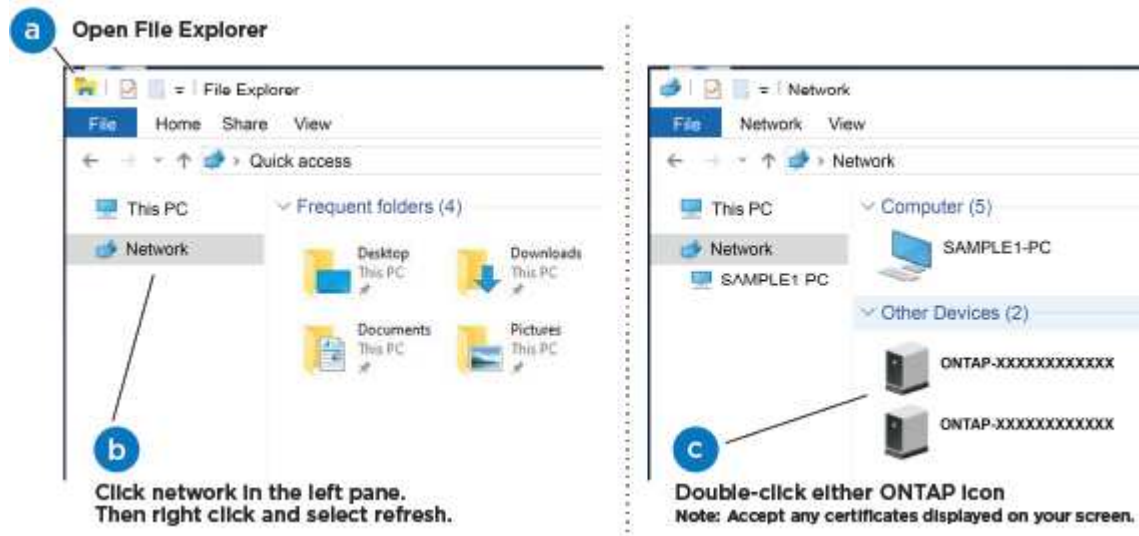

- a. Open File Explorer.
- b. Click **Network** in the left pane.
- c. Right-click and select **refresh**.
- d. Double-click either ONTAP icon and accept any certificates displayed on your screen.

 XXXXX is the system serial number for the target node.

System Manager opens.

5. Use System Manager guided setup to configure your system using the data you collected in the [ONTAP Configuration Guide](#).
6. Verify the health of your system by running Config Advisor.
7. After you have completed the initial configuration, go to the [ONTAP & ONTAP System Manager Documentation Resources](#) page for information about configuring additional features in ONTAP.

## Option 2: Complete system setup and configuration if network discovery is not enabled

If network discovery is not enabled on your laptop, you must complete the configuration and setup using this task.

### Steps

1. Cable and configure your laptop or console:
  - a. Set the console port on the laptop or console to 115,200 baud with N-8-1.

 See your laptop or console's online help for how to configure the console port.

- b. Connect the console cable to the laptop or console, and connect the console port on the controller using the console cable that came with your system.

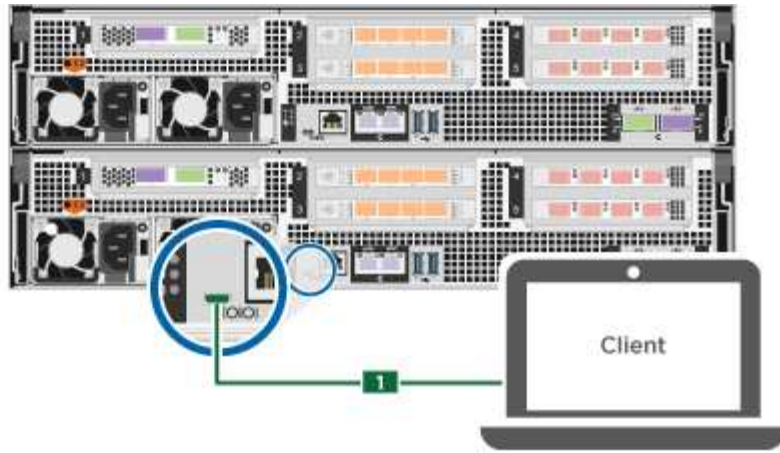

c. Connect the laptop or console to the switch on the management subnet.

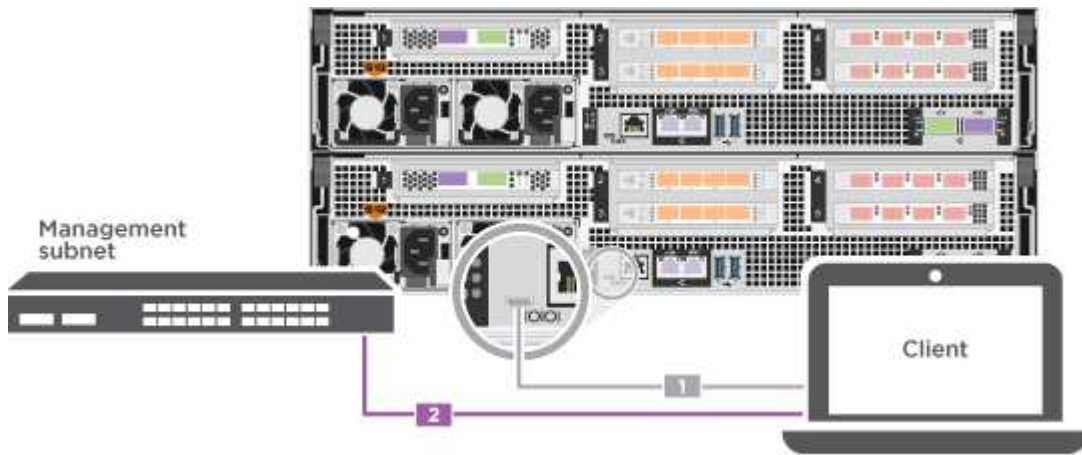

d. Assign a TCP/IP address to the laptop or console, using one that is on the management subnet.

2. Plug the power cords into the controller power supplies, and then connect them to power sources on different circuits.

The system begins to boot. Initial booting may take up to eight minutes.

3. Assign an initial node management IP address to one of the nodes.

If the management network has DHCP...	Then...
Configured	Record the IP address assigned to the new controllers.
Not configured	<p>a. Open a console session using PuTTY, a terminal server, or the equivalent for your environment.</p> <div style="display: flex; align-items: center; margin: 10px 0;"> <div style="text-align: center; margin-right: 10px;"> <span style="font-size: 2em;">i</span> </div> <div> <p>Check your laptop or console's online help if you do not know how to configure PuTTY.</p> </div> </div> <p>b. Enter the management IP address when prompted by the script.</p>

4. Using System Manager on your laptop or console, configure your cluster:

- a. Point your browser to the node management IP address.



The format for the address is `https://x.x.x.x`.

- b. Configure the system using the data you collected in the [ONTAP Configuration Guide](#).
5. Verify the health of your system by running Config Advisor.
6. After you have completed the initial configuration, go to the [ONTAP & ONTAP System Manager Documentation Resources](#) page for information about configuring additional features in ONTAP.

## Maintain

### Maintain ASA A800 hardware

For the ASA A800 storage system, you can perform maintenance procedures on the following components.

#### Boot media

The boot media stores a primary and secondary set of boot image files that the system uses when it boots.

#### Chassis

The chassis is the physical enclosure housing all the controller components such as the controller/CPU unit, power supply, and I/O.

#### Controller

A controller consists of a board, firmware, and software. It controls the drives and implements the ONTAP functions.

#### DIMM

You must replace a DIMM (dual in-line memory module) when a memory mismatch is present, or you have a failed DIMM.

#### Drive

A drive is a device that provides the physical storage media for data.

#### Fan

The fan cools the controller.

#### NVDIMM

The NVDIMM (non-volatile dual in-line memory module) manages the data transfer from the volatile memory to the non-volatile storage, and maintains data integrity in the event of a power loss or system shutdown.

#### NVDIMM battery

A NVDIMM battery is responsible for maintaining power to the NVDIMM module.

## PCIe card

A PCIe (peripheral component interconnect express) card is an expansion card that plugs into the PCIe slot on the motherboard.

## Power supply

A power supply provides a redundant power source in a controller shelf.

## Real-time clock battery

A real time clock battery preserves system date and time information if the power is off.

## Boot media

### Overview of boot media replacement - ASA A800

- You must replace the failed component with a replacement FRU component you received from your provider.
- It is important that you apply the commands in these steps on the correct controller:
  - The *impaired* controller is the controller on which you are performing maintenance.
  - The *healthy* controller is the HA partner of the impaired controller.

### Check onboard encryption keys - ASA A800

Prior to shutting down the impaired controller and checking the status of the onboard encryption keys, you must check the status of the impaired controller, disable automatic giveback, and check which version of ONTAP is running on the system.

If you have a cluster with more than two nodes, it must be in quorum. If the cluster is not in quorum or a healthy controller shows false for eligibility and health, you must correct the issue before shutting down the impaired controller; see the [Synchronize a node with the cluster](#).

### Steps

1. Check the status of the impaired controller:
  - If the impaired controller is at the login prompt, log in as `admin`.
  - If the impaired controller is at the LOADER prompt and is part of HA configuration, log in as `admin` on the healthy controller.
  - If the impaired controller is in a standalone configuration and at LOADER prompt, contact [mysupport.netapp.com](http://mysupport.netapp.com).
2. If AutoSupport is enabled, suppress automatic case creation by invoking an AutoSupport message:

```
system node autosupport invoke -node * -type all -message  
MAINT=number_of_hours_downh
```

The following AutoSupport message suppresses automatic case creation for two hours: `cluster1:*>`

```
system node autosupport invoke -node * -type all -message MAINT=2h
```
3. Check the version of ONTAP the system is running on the impaired controller if up, or on the partner controller if the impaired controller is down, using the `version -v` command:

- If <Ino-DARE> or <1Ono-DARE> is displayed in the command output, the system does not support NVE, proceed to shut down the controller.
  - If <Ino-DARE> is not displayed in the command output, and the system is running ONTAP 9.5, go to [Option 1: Check NVE or NSE on systems running ONTAP 9.5 and earlier](#).
  - If <Ino-DARE> is not displayed in the command output, and the system is running ONTAP 9.6 or later, go to [Option 2: Check NVE or NSE on systems running ONTAP 9.6 and later](#).
4. If the impaired controller is part of an HA configuration, disable automatic giveback from the healthy controller: `storage failover modify -node local -auto-giveback false` or `storage failover modify -node local -auto-giveback-after-panic false`

### Option 1: Check NVE or NSE on systems running ONTAP 9.5 and earlier

Before shutting down the impaired controller, you need to check whether the system has either NetApp Volume Encryption (NVE) or NetApp Storage Encryption (NSE) enabled. If so, you need to verify the configuration.

#### Steps

1. Connect the console cable to the impaired controller.
2. Check whether NVE is configured for any volumes in the cluster: `volume show -is-encrypted true`

If any volumes are listed in the output, NVE is configured and you need to verify the NVE configuration. If no volumes are listed, check whether NSE is configured.

3. Check whether NSE is configured: `storage encryption disk show`
  - If the command output lists the drive details with Mode & Key ID information, NSE is configured and you need to verify the NSE configuration.
  - If NVE and NSE are not configured, it's safe to shut down the impaired controller.

### Verify NVE configuration

#### Steps

1. Display the key IDs of the authentication keys that are stored on the key management servers: `security key-manager query`
  - If the `Restored` column displays `yes` and all key managers display `available`, it's safe to shut down the impaired controller.
  - If the `Restored` column displays anything other than `yes`, or if any key manager displays `unavailable`, you need to complete some additional steps.
  - If you see the message `This command is not supported when onboard key management is enabled`, you need to complete some other additional steps.
2. If the `Restored` column displayed anything other than `yes`, or if any key manager displayed `unavailable`:
  - a. Retrieve and restore all authentication keys and associated key IDs: `security key-manager restore -address *`

If the command fails, contact NetApp Support.

[mysupport.netapp.com](https://mysupport.netapp.com)
  - b. Verify that the `Restored` column displays `yes` for all authentication keys and that all key managers

display available: security key-manager query

c. Shut down the impaired controller.

3. If you saw the message This command is not supported when onboard key management is enabled, display the keys stored in the onboard key manager: `security key-manager key show -detail`

a. If the Restored column displays `yes` manually back up the onboard key management information:

- Go to advanced privilege mode and enter `y` when prompted to continue: `set -priv advanced`
- Enter the command to display the OKM backup information: `security key-manager backup show`
- Copy the contents of the backup information to a separate file or your log file. You'll need it in disaster scenarios where you might need to manually recover OKM.
- Return to admin mode: `set -priv admin`
- Shut down the impaired controller.

b. If the Restored column displays anything other than `yes`:

- Run the key-manager setup wizard: `security key-manager setup -node target/impaired node name`



Enter the customer's onboard key management passphrase at the prompt. If the passphrase cannot be provided, contact [mysupport.netapp.com](https://mysupport.netapp.com)

- Verify that the Restored column displays `yes` for all authentication key: `security key-manager key show -detail`
- Go to advanced privilege mode and enter `y` when prompted to continue: `set -priv advanced`
- Enter the command to display the OKM backup information: `security key-manager backup show`
- Copy the contents of the backup information to a separate file or your log file. You'll need it in disaster scenarios where you might need to manually recover OKM.
- Return to admin mode: `set -priv admin`
- You can safely shutdown the controller.

## Verify NSE configuration

### Steps

1. Display the key IDs of the authentication keys that are stored on the key management servers: `security key-manager query`
  - If the Restored column displays `yes` and all key managers display `available`, it's safe to shut down the impaired controller.
  - If the Restored column displays anything other than `yes`, or if any key manager displays `unavailable`, you need to complete some additional steps.
  - If you see the message This command is not supported when onboard key management is enabled, you need to complete some other additional steps
2. If the Restored column displayed anything other than `yes`, or if any key manager displayed `unavailable`:

- a. Retrieve and restore all authentication keys and associated key IDs: `security key-manager restore -address *`

If the command fails, contact NetApp Support.

[mysupport.netapp.com](https://mysupport.netapp.com)

- b. Verify that the `Restored` column displays `yes` for all authentication keys and that all key managers display `available: security key-manager query`
  - c. Shut down the impaired controller.
3. If you saw the message `This command is not supported when onboard key management is enabled`, display the keys stored in the onboard key manager: `security key-manager key show -detail`
    - a. If the `Restored` column displays `yes`, manually back up the onboard key management information:
      - Go to advanced privilege mode and enter `y` when prompted to continue: `set -priv advanced`
      - Enter the command to display the OKM backup information: `security key-manager backup show`
      - Copy the contents of the backup information to a separate file or your log file. You'll need it in disaster scenarios where you might need to manually recover OKM.
      - Return to admin mode: `set -priv admin`
      - Shut down the impaired controller.
    - b. If the `Restored` column displays anything other than `yes`:
      - Run the key-manager setup wizard: `security key-manager setup -node target/impaired node name`

Enter the customer's OKM passphrase at the prompt. If the passphrase cannot be provided, contact [mysupport.netapp.com](https://mysupport.netapp.com)
      - Verify that the `Restored` column shows `yes` for all authentication keys: `security key-manager key show -detail`
      - Go to advanced privilege mode and enter `y` when prompted to continue: `set -priv advanced`
      - Enter the command to back up the OKM information: `security key-manager backup show`

Make sure that OKM information is saved in your log file. This information will be needed in disaster scenarios where OKM might need to be manually recovered.
      - Copy the contents of the backup information to a separate file or your log. You'll need it in disaster scenarios where you might need to manually recover OKM.
      - Return to admin mode: `set -priv admin`
      - You can safely shut down the controller.

## Option 2: Check NVE or NSE on systems running ONTAP 9.6 and later

Before shutting down the impaired controller, you need to verify whether the system has either NetApp Volume Encryption (NVE) or NetApp Storage Encryption (NSE) enabled. If so, you need to verify the configuration.

1. Verify whether NVE is in use for any volumes in the cluster: `volume show -is-encrypted true`

If any volumes are listed in the output, NVE is configured and you need to verify the NVE configuration. If no volumes are listed, check whether NSE is configured and in use.

2. Verify whether NSE is configured and in use: `storage encryption disk show`
  - If the command output lists the drive details with Mode & Key ID information, NSE is configured and you need to verify the NSE configuration and in use.
  - If no disks are shown, NSE is not configured.
  - If NVE and NSE are not configured, no drives are protected with NSE keys, it's safe to shut down the impaired controller.

## Verify NVE configuration

1. Display the key IDs of the authentication keys that are stored on the key management servers: `security key-manager key query`



After the ONTAP 9.6 release, you may have additional key manager types. The types are KMIP, AKV, and GCP. The process for confirming these types is the same as confirming external or onboard key manager types.

- If the Key Manager type displays external and the Restored column displays yes, it's safe to shut down the impaired controller.
  - If the Key Manager type displays onboard and the Restored column displays yes, you need to complete some additional steps.
  - If the Key Manager type displays external and the Restored column displays anything other than yes, you need to complete some additional steps.
  - If the Key Manager type displays onboard and the Restored column displays anything other than yes, you need to complete some additional steps.
2. If the Key Manager type displays onboard and the Restored column displays yes, manually back up the OKM information:
    - a. Go to advanced privilege mode and enter `y` when prompted to continue: `set -priv advanced`
    - b. Enter the command to display the key management information: `security key-manager onboard show-backup`
    - c. Copy the contents of the backup information to a separate file or your log file. You'll need it in disaster scenarios where you might need to manually recover OKM.
    - d. Return to admin mode: `set -priv admin`
    - e. Shut down the impaired controller.
  3. If the Key Manager type displays external and the Restored column displays anything other than yes:
    - a. Restore the external key management authentication keys to all nodes in the cluster: `security key-manager external restore`

If the command fails, contact NetApp Support.



- b. Verify that the `Restored` column equals `yes` for all authentication keys: `security key-manager key query`
  - c. Shut down the impaired controller.
4. If the `Key Manager` type displays `onboard` and the `Restored` column displays anything other than `yes`:
- a. Enter the onboard security key-manager sync command: `security key-manager onboard sync`



Enter the customer's 32 character, alphanumeric onboard key management passphrase at the prompt. If the passphrase cannot be provided, contact NetApp Support. [mysupport.netapp.com](https://mysupport.netapp.com)

- b. Verify the `Restored` column shows `yes` for all authentication keys: `security key-manager key query`
- c. Verify that the `Key Manager` type shows `onboard`, and then manually back up the OKM information.
- d. Go to advanced privilege mode and enter `y` when prompted to continue: `set -priv advanced`
- e. Enter the command to display the key management backup information: `security key-manager onboard show-backup`
- f. Copy the contents of the backup information to a separate file or your log file. You'll need it in disaster scenarios where you might need to manually recover OKM.
- g. Return to admin mode: `set -priv admin`
- h. You can safely shut down the controller.

## Verify NSE configuration

1. Display the key IDs of the authentication keys that are stored on the key management servers: `security key-manager key query -key-type NSE-AK`



After the ONTAP 9.6 release, you may have additional key manager types. The types are `KMIP`, `AKV`, and `GCP`. The process for confirming these types is the same as confirming `external` or `onboard` key manager types.

- If the `Key Manager` type displays `external` and the `Restored` column displays `yes`, it's safe to shut down the impaired controller.
  - If the `Key Manager` type displays `onboard` and the `Restored` column displays `yes`, you need to complete some additional steps.
  - If the `Key Manager` type displays `external` and the `Restored` column displays anything other than `yes`, you need to complete some additional steps.
  - If the `Key Manager` type displays `external` and the `Restored` column displays anything other than `yes`, you need to complete some additional steps.
2. If the `Key Manager` type displays `onboard` and the `Restored` column displays `yes`, manually back up the OKM information:
    - a. Go to advanced privilege mode and enter `y` when prompted to continue: `set -priv advanced`
    - b. Enter the command to display the key management information: `security key-manager onboard`

`show-backup`

- c. Copy the contents of the backup information to a separate file or your log file. You'll need it in disaster scenarios where you might need to manually recover OKM.
  - d. Return to admin mode: `set -priv admin`
  - e. You can safely shut down the controller.
3. If the `Key Manager` type displays `external` and the `Restored` column displays anything other than `yes`:
- a. Restore the external key management authentication keys to all nodes in the cluster: `security key-manager external restore`

If the command fails, contact NetApp Support.

[mysupport.netapp.com](https://mysupport.netapp.com)

- b. Verify that the `Restored` column equals `yes` for all authentication keys: `security key-manager key query`
  - c. You can safely shut down the controller.
4. If the `Key Manager` type displays `onboard` and the `Restored` column displays anything other than `yes`:
- a. Enter the onboard security key-manager sync command: `security key-manager onboard sync`
- Enter the customer's 32 character, alphanumeric onboard key management passphrase at the prompt. If the passphrase cannot be provided, contact NetApp Support.

[mysupport.netapp.com](https://mysupport.netapp.com)

- b. Verify the `Restored` column shows `yes` for all authentication keys: `security key-manager key query`
- c. Verify that the `Key Manager` type shows `onboard`, and then manually back up the OKM information.
- d. Go to advanced privilege mode and enter `y` when prompted to continue: `set -priv advanced`
- e. Enter the command to display the key management backup information: `security key-manager onboard show-backup`
- f. Copy the contents of the backup information to a separate file or your log file. You'll need it in disaster scenarios where you might need to manually recover OKM.
- g. Return to admin mode: `set -priv admin`
- h. You can safely shut down the controller.

### Shut down the controller - ASA A800

After completing the NVE or NSE tasks, you need to complete the shutdown of the impaired controller. Shut down or take over the impaired controller using the appropriate procedure for your configuration.

#### Option 1: Most systems

After completing the NVE or NSE tasks, you need to complete the shutdown of the impaired controller.

## Steps

- a. Take the impaired controller to the LOADER prompt:

If the impaired controller displays...	Then...
The LOADER prompt	Go to Remove controller module.
Waiting for giveback...	Press Ctrl-C, and then respond <code>y</code> when prompted.
System prompt or password prompt (enter system password)	Take over or halt the impaired controller from the healthy controller: <code>storage failover takeover -ofnode impaired_node_name</code>  When the impaired controller shows Waiting for giveback..., press Ctrl-C, and then respond <code>y</code> .

- b. From the LOADER prompt, enter: `printenv` to capture all boot environmental variables. Save the output to your log file.



This command may not work if the boot device is corrupted or non-functional.

## Option 2: System is in a MetroCluster



Do not use this procedure if your system is in a two-node MetroCluster configuration.

To shut down the impaired controller, you must determine the status of the controller and, if necessary, take over the controller so that the healthy controller continues to serve data from the impaired controller storage.

- If you have a cluster with more than two nodes, it must be in quorum. If the cluster is not in quorum or a healthy controller shows false for eligibility and health, you must correct the issue before shutting down the impaired controller; see [Synchronize a node with the cluster](#).
- If you have a MetroCluster configuration, you must have confirmed that the MetroCluster Configuration State is configured and that the nodes are in an enabled and normal state (`metrocluster node show`).

## Steps

1. If AutoSupport is enabled, suppress automatic case creation by invoking an AutoSupport message:

```
system node autosupport invoke -node * -type all -message  
MAINT=number_of_hours_downh
```

The following AutoSupport message suppresses automatic case creation for two hours: `cluster1:*>`

```
system node autosupport invoke -node * -type all -message MAINT=2h
```

2. Disable automatic giveback from the console of the healthy controller: `storage failover modify -node local -auto-giveback false`
3. Take the impaired controller to the LOADER prompt:

If the impaired controller is displaying...	Then...
The LOADER prompt	Go to the next step.
Waiting for giveback...	Press Ctrl-C, and then respond <i>y</i> when prompted.
System prompt or password prompt (enter system password)	Take over or halt the impaired controller from the healthy controller: <pre>storage failover takeover -ofnode impaired_node_name</pre> When the impaired controller shows Waiting for giveback..., press Ctrl-C, and then respond <i>y</i> .

## Replace the boot media - ASA A800

To replace the boot media, you must remove the impaired controller module, install the replacement boot media, and transfer the boot image to a USB flash drive.

### Step 1: Remove the controller module

You must remove the controller module from the chassis when you replace the controller module or replace a component inside the controller module.

1. If you are not already grounded, properly ground yourself.
2. Unplug the controller module power supplies from the source.
3. Release the power cable retainers, and then unplug the cables from the power supplies.
4. Loosen the hook and loop strap binding the cables to the cable management device, and then unplug the system cables and SFP and QSFP modules (if needed) from the controller module, keeping track of where the cables were connected.

Leave the cables in the cable management device so that when you reinstall the cable management device, the cables are organized.

5. Remove the cable management device from the controller module and set it aside.
6. Press down on both of the locking latches, and then rotate both latches downward at the same time.

The controller module moves slightly out of the chassis.

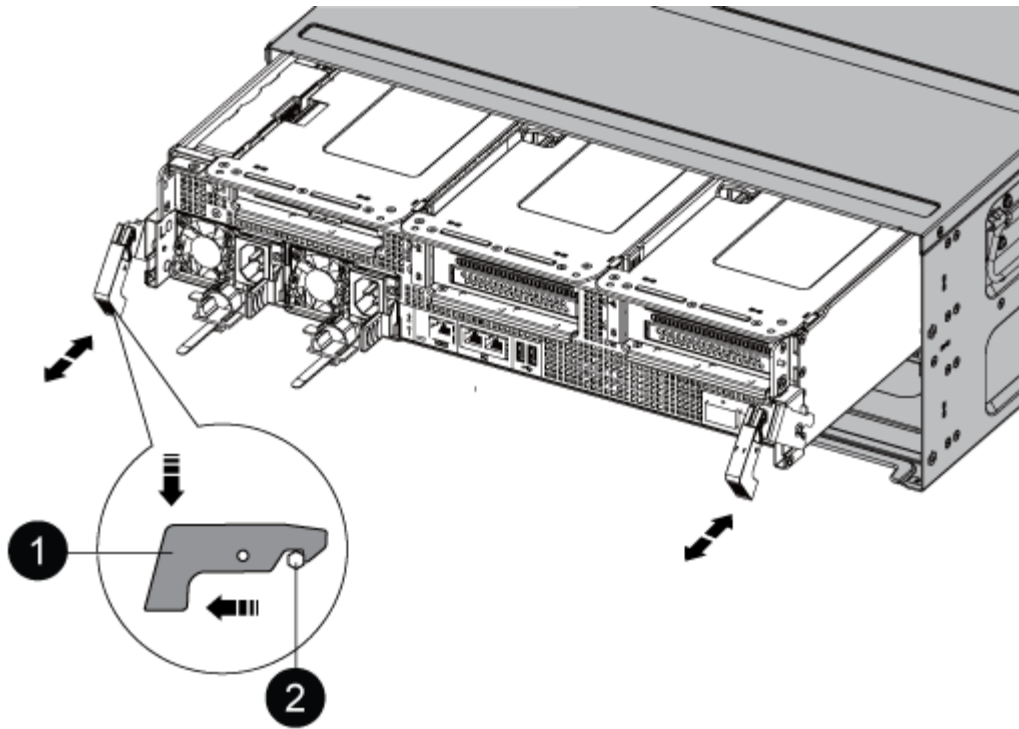

1	Locking latch
2	Locking pin

7. Slide the controller module out of the chassis.

Make sure that you support the bottom of the controller module as you slide it out of the chassis.

8. Place the controller module on a stable, flat surface, and then open the air duct:

- a. Press in the locking tabs on the sides of the air duct toward the middle of the controller module.
- b. Slide the air duct toward the fan modules, and then rotate it upward to its completely open position.

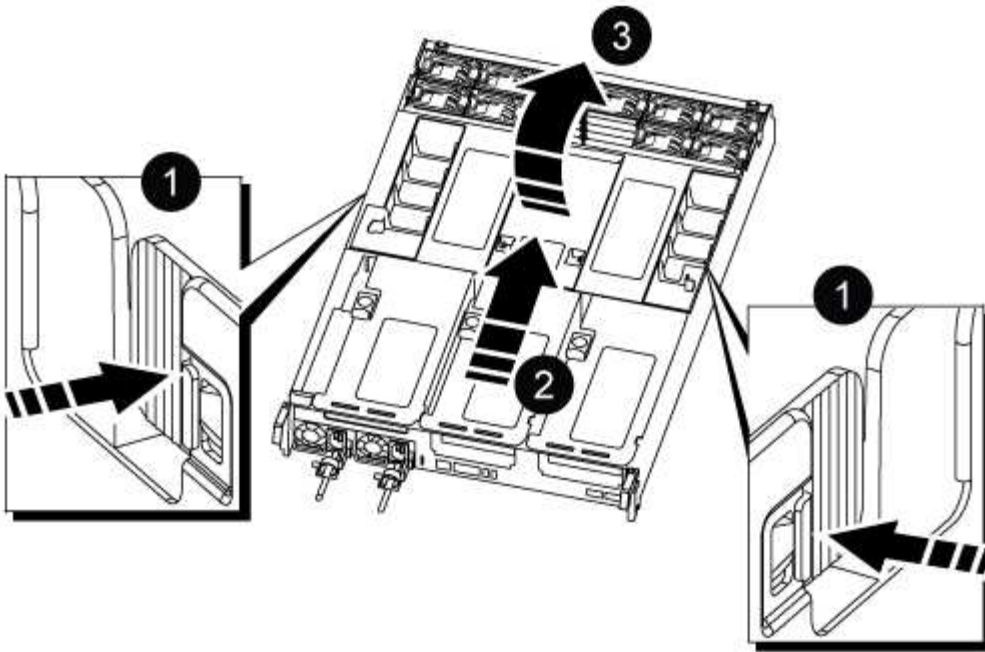

1	Air duct locking tabs
2	Slide air duct towards fan modules
3	Rotate air duct towards fan modules

**Step 2: Replace the boot media**

You locate the failed boot media in the controller module by removing Riser 3 on the controller module before you can replace the boot media.

You need a Phillips head screwdriver to remove the screw that holds the boot media in place.

1. Locate the boot media:

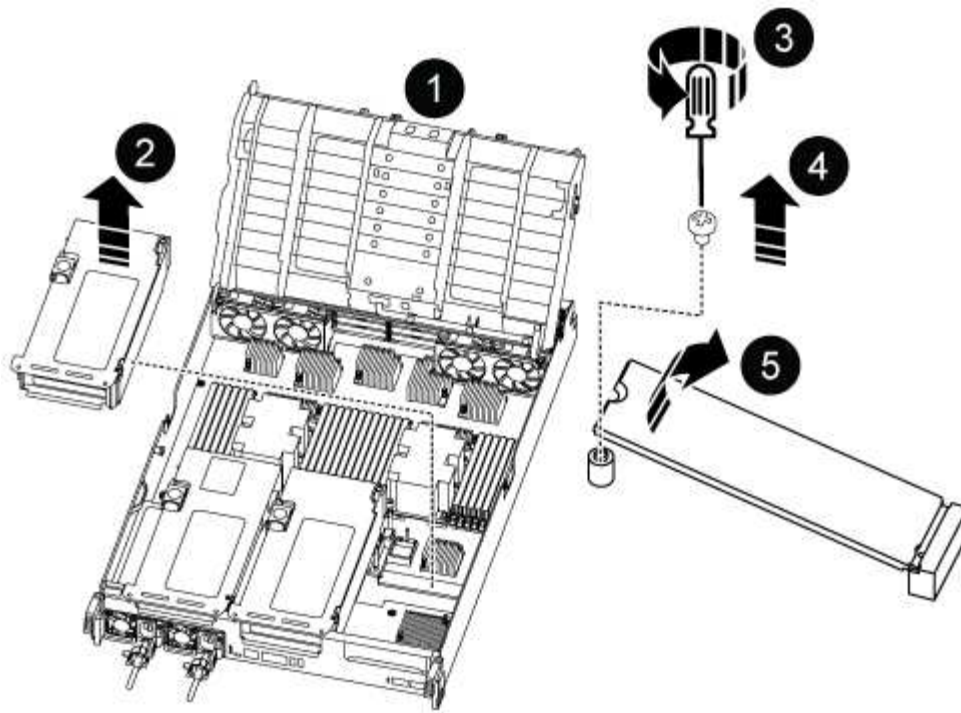

1	Air duct
2	Riser 3
3	Phillips #1 screwdriver
4	Boot media screw
5	Boot media

2. Remove the boot media from the controller module:

- a. Using a #1 Phillips head screwdriver, remove the screw holding down the boot media and set the screw aside in a safe place.
- b. Grasping the sides of the boot media, gently rotate the boot media up, and then pull the boot media straight out of the socket and set it aside.

3. Install the replacement boot media into the controller module:

- a. Align the edges of the boot media with the socket housing, and then gently push it squarely into the socket.
- b. Rotate the boot media down toward the motherboard.
- c. Secure the boot media to the motherboard using the boot media screw.

Do not over-tighten the screw or you might damage the boot media.

4. Reinstall the riser into the controller module.

5. Close the air duct:
  - a. Rotate the air duct downward.
  - b. Slide the air duct toward the risers until it clicks into place.

### Step 3: Transfer the boot image to the boot media

The replacement boot media that you installed is without a boot image so you need to transfer a boot image using a USB flash drive.

#### Before you begin

- You must have a USB flash drive, formatted to FAT32, with at least 4GB capacity.
- A copy of the same image version of ONTAP as what the impaired controller was running. You can download the appropriate image from the Downloads section on the NetApp Support Site
  - If NVE is enabled, download the image with NetApp Volume Encryption, as indicated in the download button.
  - If NVE is not enabled, download the image without NetApp Volume Encryption, as indicated in the download button.
- If your system is an HA pair, you must have a network connection.
- If your system is a stand-alone system you do not need a network connection, but you must perform an additional reboot when restoring the var file system.

#### Steps

1. Download and copy the appropriate service image from the NetApp Support Site to the USB flash drive.
  - a. Download the service image to your work space on your laptop.
  - b. Unzip the service image.



If you are extracting the contents using Windows, do not use WinZip to extract the netboot image. Use another extraction tool, such as 7-Zip or WinRAR.

There are two folders in the unzipped service image file:

- boot
- efi

- c. Copy the efi folder to the top directory on the USB flash drive.

The USB flash drive should have the efi folder and the same Service Image (BIOS) version of what the impaired controller is running.

- d. Remove the USB flash drive from your laptop.
2. If you have not already done so, close the air duct:
  - a. Swing the air duct all the way down to the controller module.
  - b. Slide the air duct toward the risers until the locking tabs click into place.
  - c. Inspect the air duct to make sure that it is properly seated and locked into place.



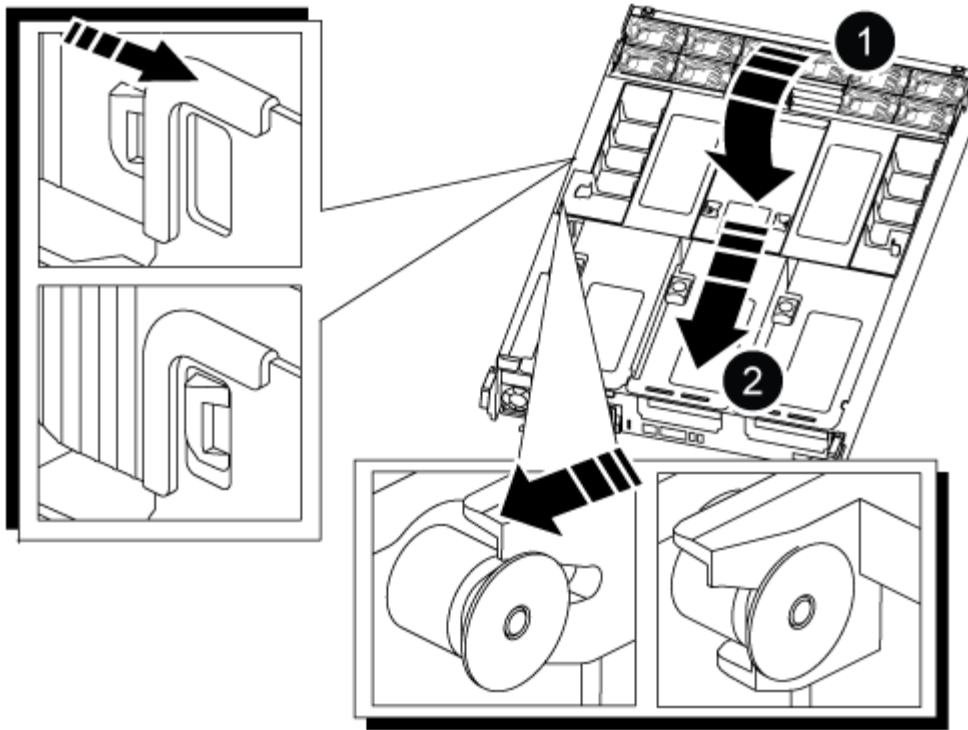

1	Air duct
2	Risers

3. Align the end of the controller module with the opening in the chassis, and then gently push the controller module halfway into the system.

4. Reinstall the cable management device and recable the system, as needed.

When recabling, remember to reinstall the media converters (SFPs or QSFPs) if they were removed.

5. Plug the power cable into the power supply and reinstall the power cable retainer.

6. Insert the USB flash drive into the USB slot on the controller module.

Make sure that you install the USB flash drive in the slot labeled for USB devices, and not in the USB console port.

7. Gently push the controller module all the way into the system until the controller module locking hooks begin to rise, firmly push on the locking hooks to finish seating the controller module, and then swing the locking hooks into the locked position over the pins on the controller module.

The controller begins to boot as soon as it is completely installed into the chassis.

8. Interrupt the boot process by pressing Ctrl-C to stop at the LOADER prompt.

If you miss this message, press Ctrl-C, select the option to boot to Maintenance mode, and then halt the controller to boot to LOADER.

## Boot the recovery image - ASA A800

Prior to shutting down the impaired controller and checking the status of the onboard encryption keys, you must check the status of the impaired controller, disable automatic giveback, and check which version of ONTAP is running on the system.

If you have a cluster with more than two nodes, it must be in quorum. If the cluster is not in quorum or a healthy controller shows false for eligibility and health, you must correct the issue before shutting down the impaired controller; see the [Synchronize a node with the cluster](#).

### Steps

1. Check the status of the impaired controller:
  - If the impaired controller is at the login prompt, log in as `admin`.
  - If the impaired controller is at the LOADER prompt and is part of HA configuration, log in as `admin` on the healthy controller.
  - If the impaired controller is in a standalone configuration and at LOADER prompt, contact [mysupport.netapp.com](http://mysupport.netapp.com).

2. If AutoSupport is enabled, suppress automatic case creation by invoking an AutoSupport message:

```
system node autosupport invoke -node * -type all -message  
MAINT=number_of_hours_downh
```

The following AutoSupport message suppresses automatic case creation for two hours: `cluster1:*>`  
`system node autosupport invoke -node * -type all -message MAINT=2h`

3. Check the version of ONTAP the system is running on the impaired controller if up, or on the partner controller if the impaired controller is down, using the `version -v` command:
  - If `<Ino-DARE>` or `<1Ono-DARE>` is displayed in the command output, the system does not support NVE, proceed to shut down the controller.
  - If `<Ino-DARE>` is not displayed in the command output, and the system is running ONTAP 9.5, go to [Option 1: Check NVE or NSE on systems running ONTAP 9.5 and earlier](#).
  - If `<Ino-DARE>` is not displayed in the command output, and the system is running ONTAP 9.6 or later, go to [Option 2: Check NVE or NSE on systems running ONTAP 9.6 and later](#).
4. If the impaired controller is part of an HA configuration, disable automatic giveback from the healthy controller: `storage failover modify -node local -auto-giveback false` or `storage failover modify -node local -auto-giveback-after-panic false`

### Option 1: Check NVE or NSE on systems running ONTAP 9.5 and earlier

Before shutting down the impaired controller, you need to check whether the system has either NetApp Volume Encryption (NVE) or NetApp Storage Encryption (NSE) enabled. If so, you need to verify the configuration.

### Steps

1. Connect the console cable to the impaired controller.
2. Check whether NVE is configured for any volumes in the cluster: `volume show -is-encrypted true`

If any volumes are listed in the output, NVE is configured and you need to verify the NVE configuration. If no volumes are listed, check whether NSE is configured.

3. Check whether NSE is configured: `storage encryption disk show`
  - If the command output lists the drive details with Mode & Key ID information, NSE is configured and you need to verify the NSE configuration.
  - If NVE and NSE are not configured, it's safe to shut down the impaired controller.

## Verify NVE configuration

### Steps

1. Display the key IDs of the authentication keys that are stored on the key management servers: `security key-manager query`
  - If the `Restored` column displays `yes` and all key managers display `available`, it's safe to shut down the impaired controller.
  - If the `Restored` column displays anything other than `yes`, or if any key manager displays `unavailable`, you need to complete some additional steps.
  - If you see the message `This command is not supported when onboard key management is enabled`, you need to complete some other additional steps.
2. If the `Restored` column displayed anything other than `yes`, or if any key manager displayed `unavailable`:
  - a. Retrieve and restore all authentication keys and associated key IDs: `security key-manager restore -address *`  
  
If the command fails, contact NetApp Support.  
  
[mysupport.netapp.com](https://mysupport.netapp.com)
  - b. Verify that the `Restored` column displays `yes` for all authentication keys and that all key managers display `available`: `security key-manager query`
  - c. Shut down the impaired controller.
3. If you saw the message `This command is not supported when onboard key management is enabled`, display the keys stored in the onboard key manager: `security key-manager key show -detail`
  - a. If the `Restored` column displays `yes` manually back up the onboard key management information:
    - Go to advanced privilege mode and enter `y` when prompted to continue: `set -priv advanced`
    - Enter the command to display the OKM backup information: `security key-manager backup show`
    - Copy the contents of the backup information to a separate file or your log file. You'll need it in disaster scenarios where you might need to manually recover OKM.
    - Return to admin mode: `set -priv admin`
    - Shut down the impaired controller.
  - b. If the `Restored` column displays anything other than `yes`:
    - Run the key-manager setup wizard: `security key-manager setup -node target/impaired node name`



Enter the customer's onboard key management passphrase at the prompt. If the passphrase cannot be provided, contact [mysupport.netapp.com](https://mysupport.netapp.com)

- Verify that the `Restored` column displays `yes` for all authentication key: `security key-manager key show -detail`
- Go to advanced privilege mode and enter `y` when prompted to continue: `set -priv advanced`
- Enter the command to display the OKM backup information: `security key-manager backup show`
- Copy the contents of the backup information to a separate file or your log file. You'll need it in disaster scenarios where you might need to manually recover OKM.
- Return to admin mode: `set -priv admin`
- You can safely shutdown the controller.

## Verify NSE configuration

### Steps

1. Display the key IDs of the authentication keys that are stored on the key management servers: `security key-manager query`
  - If the `Restored` column displays `yes` and all key managers display `available`, it's safe to shut down the impaired controller.
  - If the `Restored` column displays anything other than `yes`, or if any key manager displays `unavailable`, you need to complete some additional steps.
  - If you see the message `This command is not supported when onboard key management is enabled`, you need to complete some other additional steps
2. If the `Restored` column displayed anything other than `yes`, or if any key manager displayed `unavailable`:
  - a. Retrieve and restore all authentication keys and associated key IDs: `security key-manager restore -address *`  
  
If the command fails, contact NetApp Support.  
  
[mysupport.netapp.com](https://mysupport.netapp.com)
  - b. Verify that the `Restored` column displays `yes` for all authentication keys and that all key managers display `available`: `security key-manager query`
  - c. Shut down the impaired controller.
3. If you saw the message `This command is not supported when onboard key management is enabled`, display the keys stored in the onboard key manager: `security key-manager key show -detail`
  - a. If the `Restored` column displays `yes`, manually back up the onboard key management information:
    - Go to advanced privilege mode and enter `y` when prompted to continue: `set -priv advanced`
    - Enter the command to display the OKM backup information: `security key-manager backup show`
    - Copy the contents of the backup information to a separate file or your log file. You'll need it in disaster scenarios where you might need to manually recover OKM.

- Return to admin mode: `set -priv admin`
- Shut down the impaired controller.

b. If the `Restored` column displays anything other than `yes`:

- Run the key-manager setup wizard: `security key-manager setup -node target/impaired node name`



Enter the customer's OKM passphrase at the prompt. If the passphrase cannot be provided, contact [mysupport.netapp.com](https://mysupport.netapp.com)

- Verify that the `Restored` column shows `yes` for all authentication keys: `security key-manager key show -detail`
- Go to advanced privilege mode and enter `y` when prompted to continue: `set -priv advanced`
- Enter the command to back up the OKM information: `security key-manager backup show`



Make sure that OKM information is saved in your log file. This information will be needed in disaster scenarios where OKM might need to be manually recovered.

- Copy the contents of the backup information to a separate file or your log. You'll need it in disaster scenarios where you might need to manually recover OKM.
- Return to admin mode: `set -priv admin`
- You can safely shut down the controller.

## Option 2: Check NVE or NSE on systems running ONTAP 9.6 and later

Before shutting down the impaired controller, you need to verify whether the system has either NetApp Volume Encryption (NVE) or NetApp Storage Encryption (NSE) enabled. If so, you need to verify the configuration.

1. Verify whether NVE is in use for any volumes in the cluster: `volume show -is-encrypted true`

If any volumes are listed in the output, NVE is configured and you need to verify the NVE configuration. If no volumes are listed, check whether NSE is configured and in use.

2. Verify whether NSE is configured and in use: `storage encryption disk show`
  - If the command output lists the drive details with Mode & Key ID information, NSE is configured and you need to verify the NSE configuration and in use.
  - If no disks are shown, NSE is not configured.
  - If NVE and NSE are not configured, no drives are protected with NSE keys, it's safe to shut down the impaired controller.

## Verify NVE configuration

1. Display the key IDs of the authentication keys that are stored on the key management servers: `security key-manager key query`



After the ONTAP 9.6 release, you may have additional key manager types. The types are KMIP, AKV, and GCP. The process for confirming these types is the same as confirming external or onboard key manager types.

- If the Key Manager type displays `external` and the Restored column displays `yes`, it's safe to shut down the impaired controller.
  - If the Key Manager type displays `onboard` and the Restored column displays `yes`, you need to complete some additional steps.
  - If the Key Manager type displays `external` and the Restored column displays anything other than `yes`, you need to complete some additional steps.
  - If the Key Manager type displays `onboard` and the Restored column displays anything other than `yes`, you need to complete some additional steps.
2. If the Key Manager type displays `onboard` and the Restored column displays `yes`, manually back up the OKM information:
    - a. Go to advanced privilege mode and enter `y` when prompted to continue: `set -priv advanced`
    - b. Enter the command to display the key management information: `security key-manager onboard show-backup`
    - c. Copy the contents of the backup information to a separate file or your log file. You'll need it in disaster scenarios where you might need to manually recover OKM.
    - d. Return to admin mode: `set -priv admin`
    - e. Shut down the impaired controller.
  3. If the Key Manager type displays `external` and the Restored column displays anything other than `yes`:
    - a. Restore the external key management authentication keys to all nodes in the cluster: `security key-manager external restore`  
  
If the command fails, contact NetApp Support.  
  
[mysupport.netapp.com](https://mysupport.netapp.com)
    - b. Verify that the Restored column equals `yes` for all authentication keys: `security key-manager key query`
    - c. Shut down the impaired controller.
  4. If the Key Manager type displays `onboard` and the Restored column displays anything other than `yes`:
    - a. Enter the onboard security key-manager sync command: `security key-manager onboard sync`



Enter the customer's 32 character, alphanumeric onboard key management passphrase at the prompt. If the passphrase cannot be provided, contact NetApp Support.  
[mysupport.netapp.com](https://mysupport.netapp.com)

- b. Verify the Restored column shows `yes` for all authentication keys: `security key-manager key query`
- c. Verify that the Key Manager type shows `onboard`, and then manually back up the OKM information.

- d. Go to advanced privilege mode and enter `y` when prompted to continue: `set -priv advanced`
- e. Enter the command to display the key management backup information: `security key-manager onboard show-backup`
- f. Copy the contents of the backup information to a separate file or your log file. You'll need it in disaster scenarios where you might need to manually recover OKM.
- g. Return to admin mode: `set -priv admin`
- h. You can safely shut down the controller.

## Verify NSE configuration

1. Display the key IDs of the authentication keys that are stored on the key management servers: `security key-manager key query -key-type NSE-AK`



After the ONTAP 9.6 release, you may have additional key manager types. The types are KMIP, AKV, and GCP. The process for confirming these types is the same as confirming external or onboard key manager types.

- If the Key Manager type displays `external` and the Restored column displays `yes`, it's safe to shut down the impaired controller.
  - If the Key Manager type displays `onboard` and the Restored column displays `yes`, you need to complete some additional steps.
  - If the Key Manager type displays `external` and the Restored column displays anything other than `yes`, you need to complete some additional steps.
  - If the Key Manager type displays `external` and the Restored column displays anything other than `yes`, you need to complete some additional steps.
2. If the Key Manager type displays `onboard` and the Restored column displays `yes`, manually back up the OKM information:
    - a. Go to advanced privilege mode and enter `y` when prompted to continue: `set -priv advanced`
    - b. Enter the command to display the key management information: `security key-manager onboard show-backup`
    - c. Copy the contents of the backup information to a separate file or your log file. You'll need it in disaster scenarios where you might need to manually recover OKM.
    - d. Return to admin mode: `set -priv admin`
    - e. You can safely shut down the controller.
  3. If the Key Manager type displays `external` and the Restored column displays anything other than `yes`:
    - a. Restore the external key management authentication keys to all nodes in the cluster: `security key-manager external restore`  
  
If the command fails, contact NetApp Support.  
  
[mysupport.netapp.com](https://mysupport.netapp.com)
    - b. Verify that the Restored column equals `yes` for all authentication keys: `security key-manager key query`

- c. You can safely shut down the controller.
4. If the `Key Manager` type displays `onboard` and the `Restored` column displays anything other than `yes`:
  - a. Enter the onboard security key-manager sync command: `security key-manager onboard sync`  
  
Enter the customer's 32 character, alphanumeric onboard key management passphrase at the prompt. If the passphrase cannot be provided, contact NetApp Support.  
  
[mysupport.netapp.com](https://mysupport.netapp.com)
  - b. Verify the `Restored` column shows `yes` for all authentication keys: `security key-manager key query`
  - c. Verify that the `Key Manager` type shows `onboard`, and then manually back up the OKM information.
  - d. Go to advanced privilege mode and enter `y` when prompted to continue: `set -priv advanced`
  - e. Enter the command to display the key management backup information: `security key-manager onboard show-backup`
  - f. Copy the contents of the backup information to a separate file or your log file. You'll need it in disaster scenarios where you might need to manually recover OKM.
  - g. Return to admin mode: `set -priv admin`
  - h. You can safely shut down the controller.

## Restore OKM, NSE, and NVE - ASA A800

Once environment variables are checked, you must complete steps specific to systems that have Onboard Key Manager (OKM), NetApp Storage Encryption (NSE) or NetApp Volume Encryption (NVE) enabled.

Determine which section you should use to restore your OKM, NSE, or NVE configurations:

If NSE or NVE are enabled along with Onboard Key Manager you must restore settings you captured at the beginning of this procedure.

- If NSE or NVE are enabled and Onboard Key Manager is enabled, go to [Option 1: Restore NVE or NSE when Onboard Key Manager is enabled](#).
- If NSE or NVE are enabled for ONATP 9.5, go to [Option 2: Restore NSE/NVE on systems running ONTAP 9.5 and earlier](#).
- If NSE or NVE are enabled for ONTAP 9.6, go to [Option 3: Restore NSE/NVE on systems running ONTAP 9.6 and later](#).

### Option 1: Restore NVE or NSE when Onboard Key Manager is enabled

#### Steps

1. Connect the console cable to the target controller.
2. Use the `boot_ontap` command at the `LOADER` prompt to boot the controller.
3. Check the console output:



If the console displays...	Then...
The LOADER prompt	Boot the controller to the boot menu: <code>boot_ontap menu</code>
Waiting for giveback...	<ul style="list-style-type: none"> <li>a. Enter <code>Ctrl-C</code> at the prompt</li> <li>b. At the message: <code>Do you wish to halt this controller rather than wait [y/n]?</code> , enter: <code>y</code></li> <li>c. At the LOADER prompt, enter the <code>boot_ontap menu</code> command.</li> </ul>

4. At the Boot Menu, enter the hidden command, `recover_onboard_keymanager` and reply `y` at the prompt.
5. Enter the passphrase for the onboard key manager you obtained from the customer at the beginning of this procedure.
6. When prompted to enter the backup data, paste the backup data you captured at the beginning of this procedure, when asked. Paste the output of `security key-manager backup show` OR `security key-manager onboard show-backup` command.



The data is output from either `security key-manager backup show` or `security key-manager onboard show-backup` command.

Example of backup data:

```

-----BEGIN BACKUP-----
TmV0QXBwIEtleSBCbG9iAAEAAAAEAAAAcAEAAAAAADuD+byAAAAACEAAAAAAAAA
QAAAAAAAAABvOIH0AAAAAMh7qDLRyH1DBz12piVdy9ATSFMT0C0TIYFss4PDjTaV
dzRYkLd1PhQLxAWJwOlyqSr8qY1SEBgm1IWgE5DLRqkiAAAAAAAAACgAAAAAAAA
3WTh7gAAAAAAAAAAAAAAAAAIAAAAAAAgAZJEIwvdeHr5RCAvHGclo+wAAAAAAAA
lgAAAAAAAAAoAAAAAAAAEOTcR0AAAAAAAAAAAAAAAAACAAAAAAAAJAGr3tJA/
LRzUQRHwv+1aWvAAAAAAAAAAACQAAAAAAAAAgAAAAAAAAACdhTcvAAAAAJ1PXeBf
ml4NBsSyV1B4jc4A7cvWEFY6ILG6hc6tbKLAHZuvfQ4rlbYAAAAAAAAAAAAAAAA
AAAAAAAAAAAAAAAAAAAAAAAAAAAAAAAAAAAAAAAAAAAAAAAAAAAAAAAAAAAAAAAA
AAAAAAAAAAAAAAAAAAAAAAAAAAAAAAAAAAAAAAAAAAAAAAAAAAAAAAAAAAAAAAAA
.
.
.
.
H4nPQM0nrDRYRa9SCv8AAAAAAAAAAAAAAAAAAAAAAAAAAAAAAAAAAAAAAAAAAAA
AAAAAAAAAAAAAAAAAAAAAAAAAAAAAAAAAAAAAAAAAAAAAAAAAAAAAAAAAAAAAAAA
AAAAAAAA
-----END BACKUP-----

```

7. At the Boot Menu select the option for Normal Boot.  
The system boots to `Waiting for giveback...` prompt.
8. Move the console cable to the partner controller and login as admin.

9. Confirm the target controller is ready for giveback with the `storage failover show` command.
10. Give back only the CFO aggregates with the `storage failover giveback -fromnode local -only-cfo -aggregates true` command.
  - If the command fails because of a failed disk, physically disengage the failed disk, but leave the disk in the slot until a replacement is received.
  - If the command fails because of an open CIFS session, check with the customer on how to close out CIFS sessions.



Terminating CIFS can cause loss of data.

- If the command fails because the partner is "not ready", wait 5 minutes for the NVMEMs to synchronize.
  - If the command fails because of an NDMP, SnapMirror, or SnapVault process, disable the process. See the appropriate Documentation Center for more information.
11. Once the giveback completes, check the failover and giveback status with the `storage failover show` and ``storage failover show-giveback`` commands.

Only the CFO aggregates (root aggregate and CFO style data aggregates) will be shown.

12. Move the console cable to the target controller.
13. If you are running ONTAP 9.5 and earlier, run the key-manager setup wizard:
  - a. Start the wizard using the `security key-manager setup -nodenodename` command, and then enter the passphrase for onboard key management when prompted.
  - b. Enter the `key-manager key show -detail` command to see a detailed view of all keys stored in the onboard key manager and verify that the `Restored` column = `yes` for all authentication keys.



If the `Restored` column = anything other than `yes`, contact Customer Support.

- c. Wait 10 minutes for the key to synchronize across the cluster.
14. If you are running ONTAP 9.6 or later:
  - a. Run the `security key-manager onboard sync` command and then enter the passphrase when prompted.
  - b. Enter the `security key-manager key query` command to see a detailed view of all keys stored in the onboard key manager and verify that the `Restored` column = `yes/true` for all authentication keys.



If the `Restored` column = anything other than `yes/true`, contact Customer Support.

- c. Wait 10 minutes for the key to synchronize across the cluster.
15. Move the console cable to the partner controller.
16. Give back the target controller using the `storage failover giveback -fromnode local` command.
17. Check the giveback status, 3 minutes after it reports complete, using the `storage failover show` command.

If giveback is not complete after 20 minutes, contact Customer Support.

18. At the clustershell prompt, enter the `net int show -is-home false` command to list the logical interfaces that are not on their home controller and port.

If any interfaces are listed as `false`, revert those interfaces back to their home port using the `net int revert -vserver Cluster -lif nodename` command.

19. Move the console cable to the target controller and run the `version -v` command to check the ONTAP versions.
20. Restore automatic giveback if you disabled it by using the `storage failover modify -node local -auto-giveback true` command.

## Option 2: Restore NSE/NVE on systems running ONTAP 9.5 and earlier

### Steps

1. Connect the console cable to the target controller.
2. Use the `boot_ontap` command at the LOADER prompt to boot the controller.
3. Check the console output:

If the console displays...	Then...
The login prompt	Go to Step 7.
Waiting for giveback...	<ol style="list-style-type: none"><li>a. Log into the partner controller.</li><li>b. Confirm the target controller is ready for giveback with the <code>storage failover show</code> command.</li></ol>

4. Move the console cable to the partner controller and give back the target controller storage using the `storage failover giveback -fromnode local -only-cfo-aggregates true local` command.
  - If the command fails because of a failed disk, physically disengage the failed disk, but leave the disk in the slot until a replacement is received.
  - If the command fails because of an open CIFS sessions, check with customer how to close out CIFS sessions.



Terminating CIFS can cause loss of data.

- If the command fails because the partner "not ready", wait 5 minutes for the NVMEMs to synchronize.
  - If the command fails because of an NDMP, SnapMirror, or SnapVault process, disable the process. See the appropriate Documentation Center for more information.
5. Wait 3 minutes and check the failover status with the `storage failover show` command.
  6. At the clustershell prompt, enter the `net int show -is-home false` command to list the logical interfaces that are not on their home controller and port.

If any interfaces are listed as `false`, revert those interfaces back to their home port using the `net int`

```
revert -vserver Cluster -lif nodename command.
```

7. Move the console cable to the target controller and run the `version -v` command to check the ONTAP versions.
8. Restore automatic giveback if you disabled it by using the `storage failover modify -node local -auto-giveback true` command.
9. Use the `storage encryption disk show` at the clustershell prompt, to review the output.



This command does not work if NVE (NetApp Volume Encryption) is configured

10. Use the `security key-manager query` to display the key IDs of the authentication keys that are stored on the key management servers.
  - If the `Restored` column = `yes` and all key managers report in an available state, go to *Complete the replacement process*.
  - If the `Restored` column = anything other than `yes`, and/or one or more key managers is not available, use the `security key-manager restore -address` command to retrieve and restore all authentication keys (AKs) and key IDs associated with all nodes from all available key management servers.

Check the output of the `security key-manager query` again to ensure that the `Restored` column = `yes` and all key managers report in an available state

11. If the Onboard Key Management is enabled:
  - a. Use the `security key-manager key show -detail` to see a detailed view of all keys stored in the onboard key manager.
  - b. Use the `security key-manager key show -detail` command and verify that the `Restored` column = `yes` for all authentication keys.

If the `Restored` column = anything other than `yes`, use the `security key-manager setup -node Repaired(Target)node` command to restore the Onboard Key Management settings. Rerun the `security key-manager key show -detail` command to verify `Restored` column = `yes` for all authentication keys.

12. Connect the console cable to the partner controller.
13. Give back the controller using the `storage failover giveback -fromnode local` command.
14. Restore automatic giveback if you disabled it by using the `storage failover modify -node local -auto-giveback true` command.

### Option 3: Restore NSE/NVE on systems running ONTAP 9.6 and later

#### Steps

1. Connect the console cable to the target controller.
2. Use the `boot_ontap` command at the LOADER prompt to boot the controller.
3. Check the console output:

If the console displays...	Then...
The login prompt	Go to Step 7.
Waiting for giveback...	<ul style="list-style-type: none"> <li>a. Log into the partner controller.</li> <li>b. Confirm the target controller is ready for giveback with the <code>storage failover show</code> command.</li> </ul>

4. Move the console cable to the partner controller and give back the target controller storage using the `storage failover giveback -fromnode local -only-cfo-aggregates true local` command.
  - If the command fails because of a failed disk, physically disengage the failed disk, but leave the disk in the slot until a replacement is received.
  - If the command fails because of an open CIFS session, check with the customer on how to close out CIFS sessions.



Terminating CIFS can cause loss of data.

- If the command fails because the partner is "not ready", wait 5 minutes for the NVMEMs to synchronize.
  - If the command fails because of an NDMP, SnapMirror, or SnapVault process, disable the process. See the appropriate Documentation Center for more information.
5. Wait 3 minutes and check the failover status with the `storage failover show` command.
  6. At the clustershell prompt, enter the `net int show -is-home false` command to list the logical interfaces that are not on their home controller and port.

If any interfaces are listed as `false`, revert those interfaces back to their home port using the `net int revert -vserver Cluster -lif nodename` command.

7. Move the console cable to the target controller and run the `version -v` command to check the ONTAP versions.
8. Restore automatic giveback if you disabled it by using the `storage failover modify -node local -auto-giveback true` command.
9. Use the `storage encryption disk show` at the clustershell prompt, to review the output.
10. Use the `security key-manager key query` command to display the key IDs of the authentication keys that are stored on the key management servers.
  - If the `Restored` column = `yes/true`, you are done and can proceed to complete the replacement process.
  - If the `Key Manager type` = `external` and the `Restored` column = anything other than `yes/true`, use the `security key-manager external restore` command to restore the key IDs of the authentication keys.



If the command fails, contact Customer Support.

- If the `Key Manager type = onboard` and the `Restored` column = anything other than `yes/true`, use the `security key-manager onboard sync` command to re-sync the Key Manager type.

Use the `security key-manager key query` to verify that the `Restored` column = `yes/true` for all authentication keys.

11. Connect the console cable to the partner controller.
12. Give back the controller using the `storage failover giveback -fromnode local` command.
13. Restore automatic giveback if you disabled it by using the `storage failover modify -node local -auto-giveback true` command.
14. If AutoSupport is enabled, restore/unsuppress automatic case creation by using the `system node autosupport invoke -node * -type all -message MAINT=END`

## Return the failed part to NetApp - ASA A800

Return the failed part to NetApp, as described in the RMA instructions shipped with the kit. See the [Part Return and Replacements](#) page for further information.

### Chassis

#### Replace the chassis - ASA A800

To replace the chassis, you must move the bezel, controller modules, and NVMe drives from the impaired chassis to the replacement chassis, and then remove the impaired chassis from the equipment rack or system cabinet and install the replacement chassis in its place.

All other components in the system must be functioning properly; if not, you must contact technical support.

- You can use this procedure with all versions of ONTAP supported by your system.
- This procedure is written with the assumption that you are moving the bezel, NVMe drives, and controller modules to the new chassis, and that the replacement chassis is a new component from NetApp.
- This procedure is disruptive. For a two-node cluster, you will have a complete service outage and a partial outage in a multi-node cluster.

#### Shut down the controllers - ASA A800

This procedure is for 2-node, non-MetroCluster configurations only. If you have a system with more than two nodes, see [How to perform a graceful shutdown and power up of one HA pair in a 4-node cluster](#).

#### Before you begin

You need:

- Local administrator credentials for ONTAP.
- NetApp onboard key management (OKM) cluster-wide passphrase if using storage encryption or NVE/NAE.
- BMC accessibility for each controller.

- Stop all clients/host from accessing data on the NetApp system.
- Suspend external backup jobs.
- Necessary tools and equipment for the replacement.



If the system is a NetApp StorageGRID or ONTAP S3 used as FabricPool cloud tier, refer to the [Gracefully shutdown and power up your storage system Resolution Guide](#) after performing this procedure.



If using SSDs, refer to [SU490: \(Impact: Critical\) SSD Best Practices: Avoid risk of drive failure and data loss if powered off for more than two months](#)

As a best practice before shutdown, you should:

- Perform additional [system health checks](#).
- Upgrade ONTAP to a recommended release for the system.
- Resolve any [Active IQ Wellness Alerts and Risks](#).  
Make note of any faults presently on the system, such as LEDs on the system components.

### Steps

1. Log into the cluster through SSH or log in from any node in the cluster using a local console cable and a laptop/console.
2. Turn off AutoSupport and indicate how long you expect the system to be offline:

```
system node autosupport invoke -node * -type all -message "MAINT=8h Power Maintenance"
```

3. Identify the SP/BMC address of all nodes:

```
system service-processor show -node * -fields address
```

4. Exit the cluster shell: `exit`
5. Log into SP/BMC over SSH using the IP address of any of the nodes listed in the output from the previous step.

If your're using a console/laptop, log into the controller using the same cluster administrator credentials.



Open an SSH session to every SP/BMC connection so that you can monitor progress.

6. Halt the 2 nodes located in the impaired chassis:

```
system node halt -node <node>,<node2> -skip-lif-migration-before-shutdown true -ignore-quorum-warnings true -inhibit-takeover true
```



For clusters using SnapMirror synchronous operating in StrictSync mode: `system node halt -node <node>,<node2> -skip-lif-migration-before-shutdown true -ignore-quorum-warnings true -inhibit-takeover true -ignore-strict-sync-warnings true`

7. Enter `y` for each controller in the cluster when you see *Warning: Are you sure you want to halt*

```
node "cluster <node-name> number"?  
{y|n}:
```

8. Wait for each controller to halt and display the LOADER prompt.

### Replace chassis - ASA A800

Move the power supplies, hard drives, and controller module from the impaired chassis to the new chassis, and swap out the impaired chassis with the new chassis of the same model as the impaired chassis.

#### Step 1: Remove the controller modules

To replace the chassis, you must remove the controller modules from the old chassis.

1. If you are not already grounded, properly ground yourself.
2. Release the power cable retainers, and then unplug the cables from the power supplies.
3. Loosen the hook and loop strap binding the cables to the cable management device, and then unplug the system cables from the controller module, keeping track of where the cables were connected.

Leave the cables in the cable management device so that when you reinstall the cable management device, the cables are organized.

4. Remove the cable management device from the controller module and set it aside.
5. Press down on both of the locking latches, and then rotate both latches downward at the same time.

The controller module moves slightly out of the chassis.

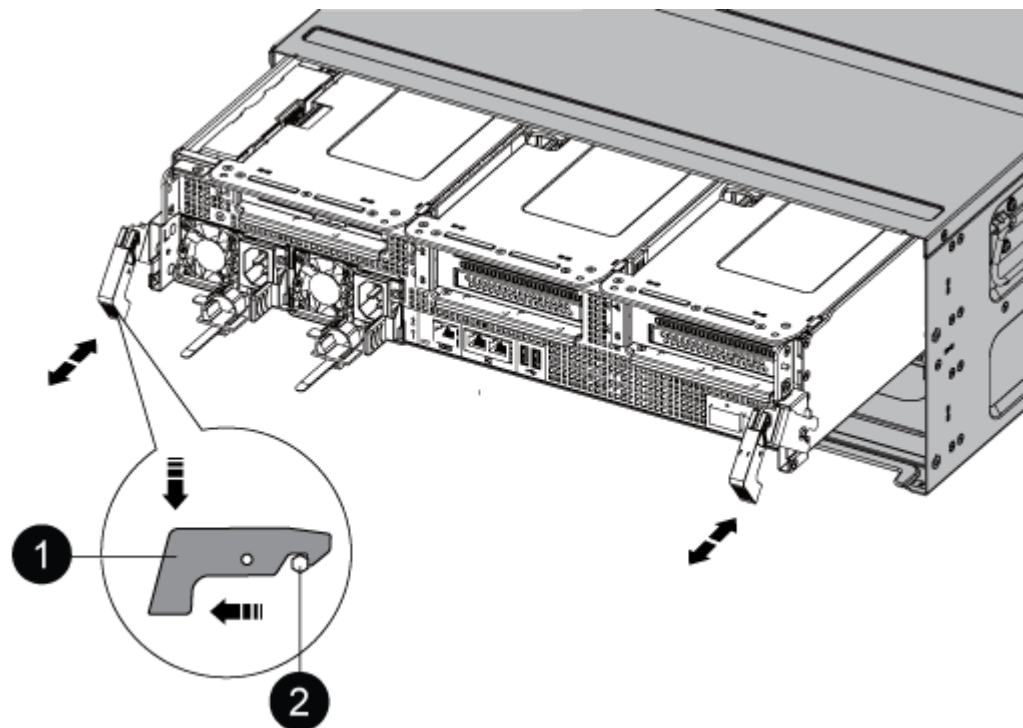

1	Locking latch
---	---------------



<b>2</b>	Locking pin
----------	-------------

6. Slide the controller module out of the chassis.

Make sure that you support the bottom of the controller module as you slide it out of the chassis.

7. Set the controller module aside in a safe place, and repeat these steps for the other controller module in the chassis.

## Step 2: Move drives to the new chassis

You need to move the drives from each bay opening in the old chassis to the same bay opening in the new chassis.

1. Gently remove the bezel from the front of the system.
2. Remove the drives:
  - a. Press the release button at the top of the carrier face below the LEDs.
  - b. Pull the cam handle to its fully open position to unseat the drive from the midplane, and then gently slide the drive out of the chassis.

The drive should disengage from the chassis, allowing it to slide free of the chassis.



When removing a drive, always use two hands to support its weight.



Drives are fragile. Handle them as little as possible to prevent damage to them.

3. Align the drive from the old chassis with the same bay opening in the new chassis.
4. Gently push the drive into the chassis as far as it will go.

The cam handle engages and begins to rotate upward.

5. Firmly push the drive the rest of the way into the chassis, and then lock the cam handle by pushing it up and against the drive holder.

Be sure to close the cam handle slowly so that it aligns correctly with the front of the drive carrier. It clicks when it is secure.

6. Repeat the process for the remaining drives in the system.

## Step 3: Replace a chassis from within the equipment rack or system cabinet

You must remove the existing chassis from the equipment rack or system cabinet before you can install the replacement chassis.

1. Remove the screws from the chassis mount points.
2. With two people, slide the old chassis off the rack rails in a system cabinet or equipment rack, and then set it aside.
3. If you are not already grounded, properly ground yourself.
4. Using two people, install the replacement chassis into the equipment rack or system cabinet by guiding the

chassis onto the rack rails in a system cabinet or equipment rack.

5. Slide the chassis all the way into the equipment rack or system cabinet.
6. Secure the front of the chassis to the equipment rack or system cabinet, using the screws you removed from the old chassis.
7. If you have not already done so, install the bezel.

#### Step 4: Install the controller modules

After you install the controller modules into the new chassis, you need to boot it.

For HA pairs with two controller modules in the same chassis, the sequence in which you install the controller module is especially important because it attempts to reboot as soon as you completely seat it in the chassis.

1. Align the end of the controller module with the opening in the chassis, and then gently push the controller module halfway into the system.



Do not completely insert the controller module in the chassis until instructed to do so.

2. Recable the console to the controller module, and then reconnect the management port.
3. Plug the power cables into the power supplies and reinstall the power cable retainers.
4. Complete the reinstallation of the controller module:
  - a. Firmly push the controller module into the chassis until it meets the midplane and is fully seated.

The locking latches rise when the controller module is fully seated.



Do not use excessive force when sliding the controller module into the chassis to avoid damaging the connectors.

The controller module begins to boot as soon as it is fully seated in the chassis. Be prepared to interrupt the boot process.

- b. Rotate the locking latches upward, tilting them so that they clear the locking pins, and then lower them into the locked position.
  - c. If you have not already done so, reinstall the cable management device.
  - d. Interrupt the normal boot process by pressing `Ctrl-C`.
5. Repeat the preceding steps to install the second controller into the new chassis.

#### Complete chassis replacement - ASA A800

You must verify the HA state of the chassis and return the failed part to NetApp, as described in the RMA instructions shipped with the kit.

#### Step 1: Verify and set the HA state of the chassis

You must verify the HA state of the chassis, and, if necessary, update the state to match your system configuration.

1. In Maintenance mode, from either controller module, display the HA state of the local controller module and chassis: `ha-config show`

The HA state should be the same for all components.

2. If the displayed system state for the chassis does not match your system configuration:

a. Set the HA state for the chassis: `ha-config modify chassis HA-state`

The value for HA-state can be one of the following:

- ha
- mcc
- mccip
- non-ha

b. Confirm that the setting has changed: `ha-config show`

3. If you have not already done so, recable the rest of your system.

4. Reinstall the bezel on the front of the system.

## Step 2: Return the failed part to NetApp

Return the failed part to NetApp, as described in the RMA instructions shipped with the kit. See the [Part Return and Replacements](#) page for further information.

### Controller

#### Overview of controller replacement - ASA A800

You must review the prerequisites for the replacement procedure and select the correct one for your version of the ONTAP operating system.

- All drive shelves must be working properly.
- The healthy controller must be able to take over the controller that is being replaced (referred to in this procedure as the “impaired controller”).
- If your system is in a MetroCluster configuration, you must review the section [Choosing the correct recovery procedure](#) to determine whether you should use this procedure.
- You must replace the failed component with a replacement FRU component you received from your provider.
- You must be replacing a controller module with a controller module of the same model type. You cannot upgrade your system by just replacing the controller module.
- You cannot change any drives or drive shelves as part of this procedure.
- In this procedure, the boot device is moved from the impaired controller to the *replacement* controller so that the *replacement* controller will boot up in the same version of ONTAP as the old controller module.
- It is important that you apply the commands in these steps on the correct systems:
  - The *impaired* controller is the controller that is being replaced.
  - The *replacement* controller is the new controller that is replacing the impaired controller.
  - The *healthy* controller is the surviving controller.
- You must always capture the controller’s console output to a text file.

This provides you a record of the procedure so that you can troubleshoot any issues that you might encounter during the replacement process.



Do not downgrade the BIOS version of the *replacement* controller to match the partner controller or the old controller module.

## Shut down the impaired controller - ASA A800

To shut down the impaired controller, you must determine the status of the controller and, if necessary, take over the controller so that the healthy controller continues to serve data from the impaired controller storage.

### About this task

- If you have a SAN system, you must have checked event messages (`cluster kernel-service show`) for the impaired controller SCSI blade. The `cluster kernel-service show` command (from `priv advanced` mode) displays the node name, quorum status of that node, availability status of that node, and operational status of that node.

Each SCSI-blade process should be in quorum with the other nodes in the cluster. Any issues must be resolved before you proceed with the replacement.

- If you have a cluster with more than two nodes, it must be in quorum. If the cluster is not in quorum or a healthy controller shows `false` for eligibility and health, you must correct the issue before shutting down the impaired controller; see [Synchronize a node with the cluster](#).

### Steps

1. If AutoSupport is enabled, suppress automatic case creation by invoking an AutoSupport message:  
`system node autosupport invoke -node * -type all -message MAINT=<# of hours>h`

The following AutoSupport message suppresses automatic case creation for two hours: `cluster1:>`  
`system node autosupport invoke -node * -type all -message MAINT=2h`

2. Disable automatic giveback from the console of the healthy controller: `storage failover modify -node local -auto-giveback false`



When you see *Do you want to disable auto-giveback?*, enter `y`.

3. Take the impaired controller to the LOADER prompt:

If the impaired controller is displaying...	Then...
The LOADER prompt	Go to the next step.
Waiting for giveback...	Press Ctrl-C, and then respond <code>y</code> when prompted.

If the impaired controller is displaying...	Then...
System prompt or password prompt	<p>Take over or halt the impaired controller from the healthy controller:  <code>storage failover takeover -ofnode  impaired_node_name</code></p> <p>When the impaired controller shows Waiting for giveback..., press Ctrl-C, and then respond <code>y</code>.</p>

## Replace the controller - ASA A800

To replace the controller, you must remove the impaired controller, move FRU components to the replacement controller module, install the replacement controller module in the chassis, and then boot the system to Maintenance mode.

### Step 1: Remove the controller module

You must remove the controller module from the chassis when you replace the controller module or replace a component inside the controller module.

1. On the front of the chassis, use your thumbs to firmly push each drive in until you feel a positive stop. This ensures that the drives are firmly seated against the chassis midplane.

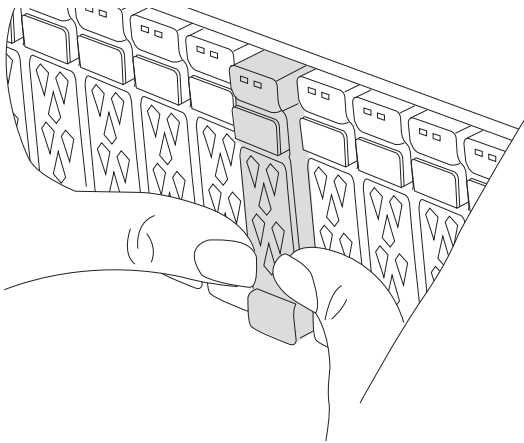

2. Go to the rear of the chassis. If you are not already grounded, properly ground yourself.
3. Unplug the controller module power supplies from the source.
4. Release the power cable retainers, and then unplug the cables from the power supplies.
5. Loosen the hook and loop strap binding the cables to the cable management device, and then unplug the system cables and SFP and QSFP modules (if needed) from the controller module, keeping track of where the cables were connected.

Leave the cables in the cable management device so that when you reinstall the cable management device, the cables are organized.

6. Remove the cable management device from the controller module and set it aside.
7. Press down on both of the locking latches, and then rotate both latches downward at the same time.

The controller module moves slightly out of the chassis.

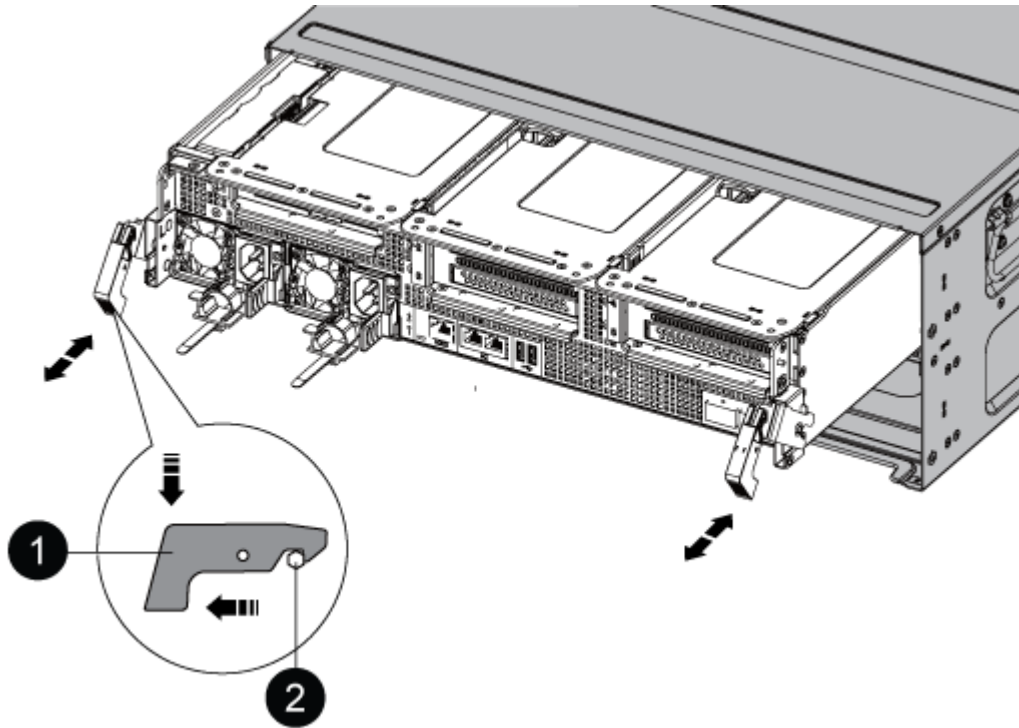

<b>1</b>	Locking latch
<b>2</b>	Locking pin

8. Slide the controller module out of the chassis and place it on a stable, flat surface.

Make sure that you support the bottom of the controller module as you slide it out of the chassis.

9. Place the controller module on a stable, flat surface.

10. Open the controller module air duct:

- a. Press in the locking tabs on the sides of the air duct toward the middle of the controller module.
- b. Slide the air duct toward the fan modules, and then rotate it upward to its completely open position.

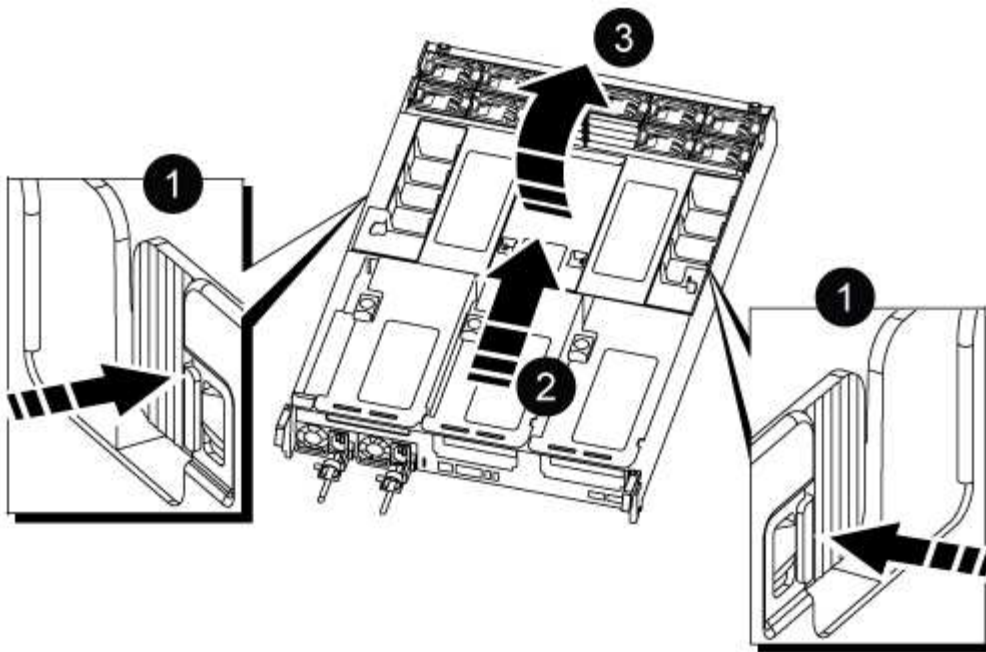

1	Air duct locking tabs
2	Slide air duct towards fan modules
3	Rotate air duct towards fan modules

## Step 2: Move the power supplies

You must move the power supplies from the impaired controller module to the replacement controller module when you replace a controller module.

1. Rotate the cam handle such that it can be used to pull power supply out of the controller module while pressing the locking tab.



The power supply is short. Always use two hands to support it when removing it from the controller module so that it does not suddenly swing free from the controller module and injure you.

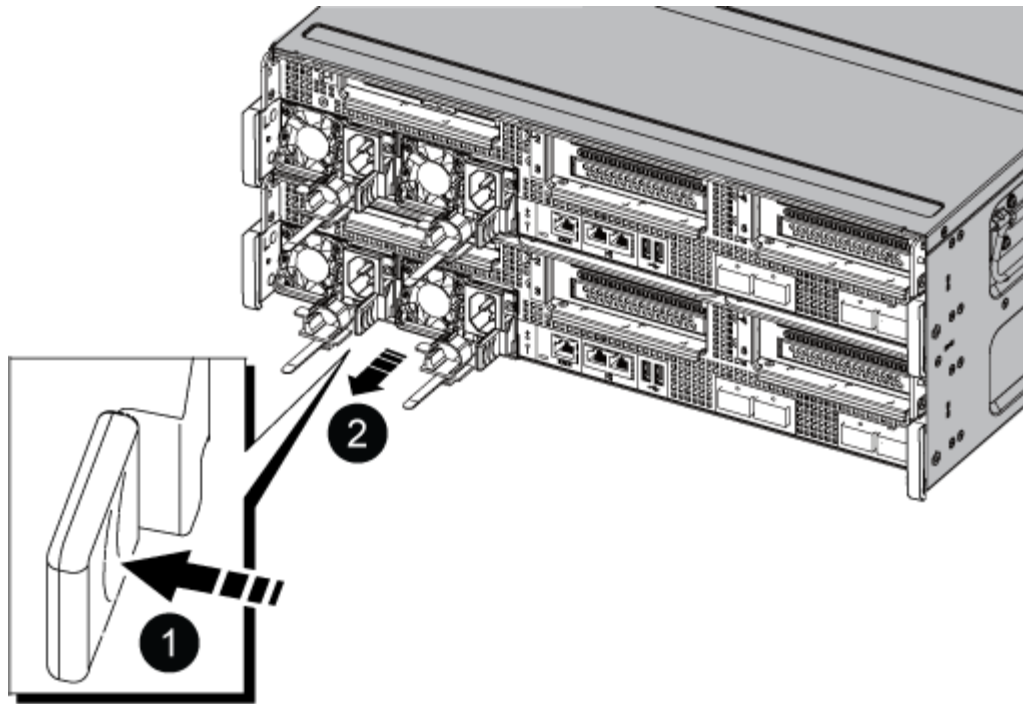

1	Blue power supply locking tab
2	Power supply

2. Move the power supply to the new controller module, and then install it.
3. Using both hands, support and align the edges of the power supply with the opening in the controller module, and then gently push the power supply into the controller module until the locking tab clicks into place.

The power supplies will only properly engage with the internal connector and lock in place one way.



To avoid damaging the internal connector, do not use excessive force when sliding the power supply into the system.

### Step 3: Move the fans

You must move the fans from the impaired controller module to the replacement module when replacing a failed controller module.

1. Remove the fan module by pinching the locking tabs on the side of the fan module, and then lifting the fan module straight out of the controller module.



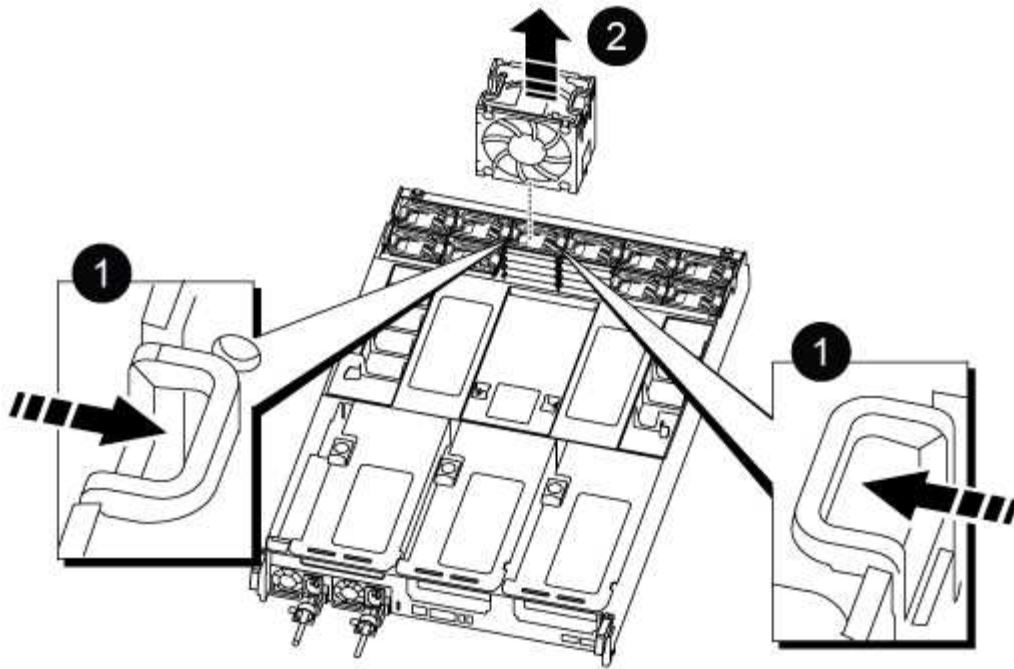

<b>1</b>
Fan locking tabs
<b>2</b>
Fan module

2. Move the fan module to the replacement controller module, and then install the fan module by aligning its edges with the opening in the controller module, and then sliding the fan module into the controller module until the locking latches click into place.
3. Repeat these steps for the remaining fan modules.

#### Step 4: Move the NVDIMM battery

When replacing the controller module, you must move the NVRAM battery from the impaired controller module to the replacement controller module

1. Open the air duct cover and locate the NVDIMM battery in the riser.

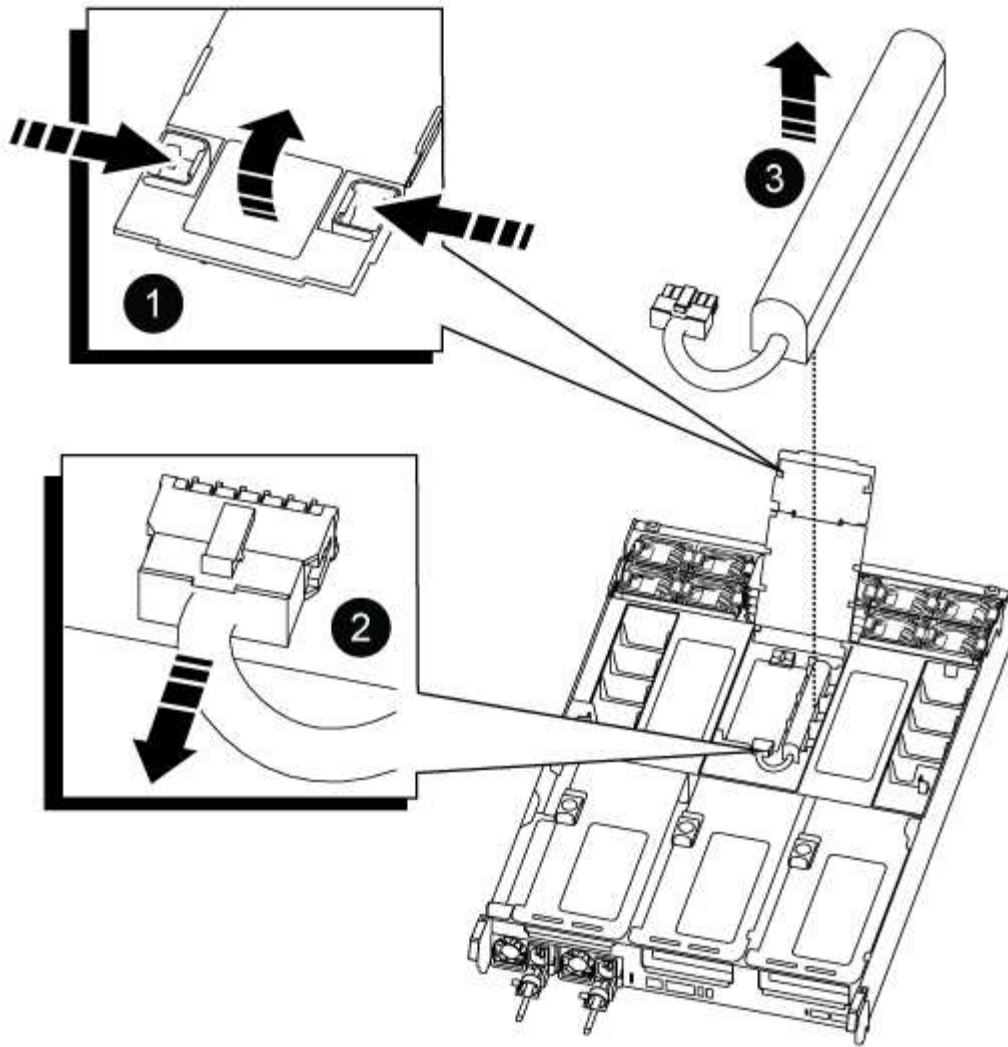

1	Air duct riser
2	NVDIMM battery plug
3	NVDIMM battery pack

**Attention:** The NVDIMM battery control board LED blinks while destaging contents to the flash memory when you halt the system. After the destage is complete, the LED turns off.

2. Locate the battery plug and squeeze the clip on the face of the battery plug to release the plug from the socket, and then unplug the battery cable from the socket.
3. Grasp the battery and lift the battery out of the air duct and controller module.
4. Move the battery pack to the replacement controller module and then install it in the NVDIMM air duct:
  - a. Insert the battery pack into the slot and press firmly down on the battery pack to make sure that it is locked into place.
  - b. Plug the battery plug into the riser socket and make sure that the plug locks into place.

## Step 5: Remove the PCIe risers

As part of the controller replacement process, you must remove the PCIe modules from the impaired controller module. You must install them into the same location in the replacement controller module once the NVDIMMs and DIMMs have moved to the replacement controller module.

1. Remove the PCIe riser from the controller module:
  - a. Remove any SFP or QSFP modules that might be in the PCIe cards.
  - b. Rotate the riser locking latch on the left side of the riser up and toward the fan modules.

The riser raises up slightly from the controller module.

- c. Lift the riser up, shift it toward the fans so that the sheet metal lip on the riser clears the edge of the controller module, lift the riser out of the controller module, and then place it on a stable, flat surface.

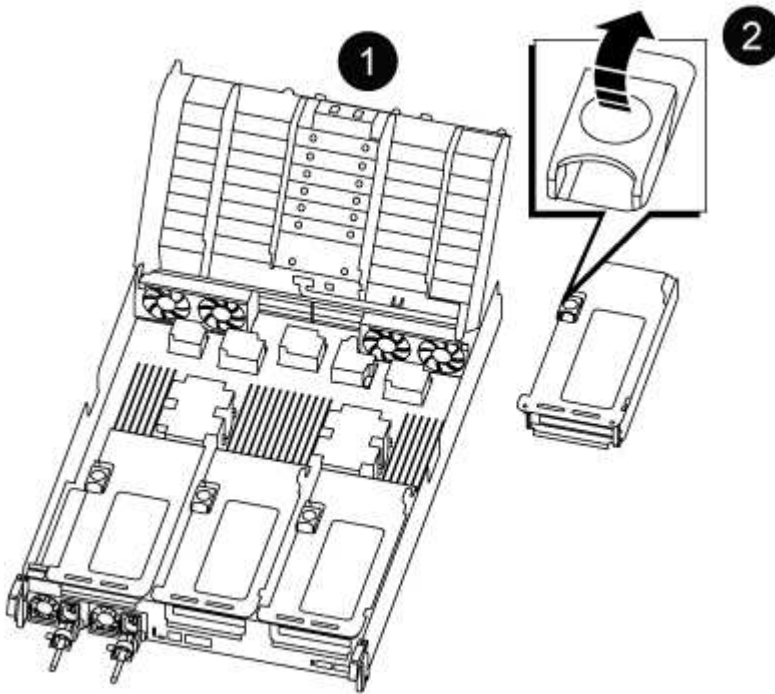

<b>1</b>	Air duct
<b>2</b>	Riser 1 (left riser), Riser 2 (middle riser), and 3 (right riser) locking latches

2. Repeat the preceding step for the remaining risers in the impaired controller module.
3. Repeat the above steps with the empty risers in the replacement controller and put them away.

## Step 6: Move system DIMMs

To move the DIMMs, locate and move them from the impaired controller into the replacement controller and follow the specific sequence of steps.

1. Note the orientation of the DIMM in the socket so that you can insert the DIMM in the replacement controller module in the proper orientation.

- Eject the DIMM from its slot by slowly pushing apart the two DIMM ejector tabs on either side of the DIMM, and then slide the DIMM out of the slot.



Carefully hold the DIMM by the edges to avoid pressure on the components on the DIMM circuit board.

- Locate the slot where you are installing the DIMM.
- Insert the DIMM squarely into the slot.

The DIMM fits tightly in the slot, but should go in easily. If not, realign the DIMM with the slot and reinsert it.



Visually inspect the DIMM to verify that it is evenly aligned and fully inserted into the slot.

- Push carefully, but firmly, on the top edge of the DIMM until the ejector tabs snap into place over the notches at the ends of the DIMM.
- Repeat these steps for the remaining DIMMs.

### Step 7: Move the NVDIMMs

To move the NVDIMMs, locate and move them from the impaired controller into the replacement controller and follow the specific sequence of steps.

- Locate the NVDIMMs on your controller module.

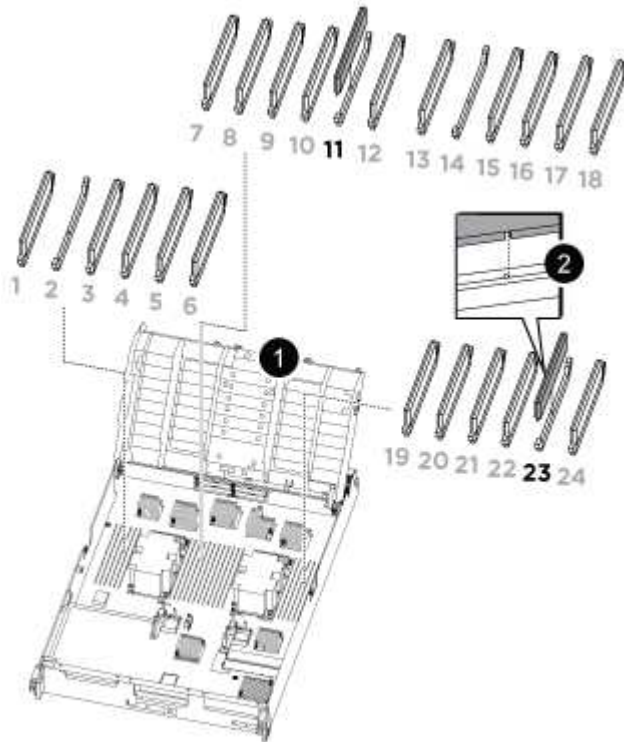

- NVDIMM: SLOTS 11 & 23

1

Air duct

2

## NVDIMMs

2. Note the orientation of the NVDIMM in the socket so that you can insert the NVDIMM in the replacement controller module in the proper orientation.
3. Eject the NVDIMM from its slot by slowly pushing apart the two NVDIMM ejector tabs on either side of the NVDIMM, and then slide the NVDIMM out of the socket and set it aside.



Carefully hold the NVDIMM by the edges to avoid pressure on the components on the NVDIMM circuit board.

4. Locate the slot where you are installing the NVDIMM.
5. Insert the NVDIMM squarely into the slot.

The NVDIMM fits tightly in the slot, but should go in easily. If not, realign the NVDIMM with the slot and reinsert it.



Visually inspect the NVDIMM to verify that it is evenly aligned and fully inserted into the slot.

6. Push carefully, but firmly, on the top edge of the NVDIMM until the ejector tabs snap into place over the notches at the ends of the NVDIMM.
7. Repeat the preceding steps to move the other NVDIMM.

### Step 8: Move the boot media

You must move the boot media device from the impaired controller and install it in the replacement controller.

The boot media is located under Riser 3.

1. Locate the boot media:

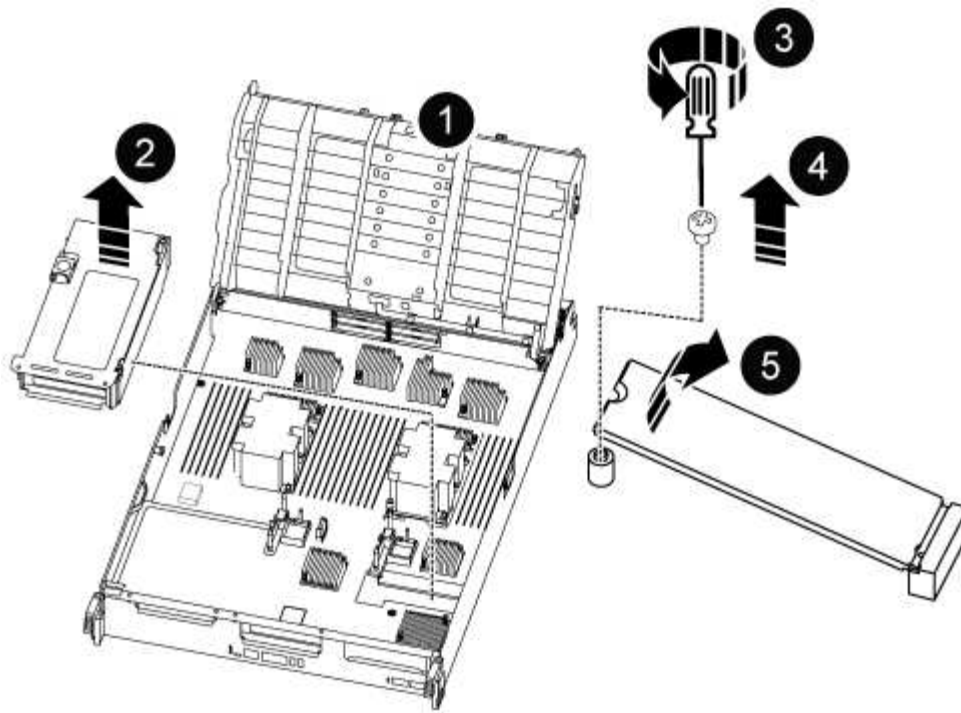

1	Air duct
2	Riser 3
3	Phillips #1 screwdriver
4	Boot media screw
5	Boot media

2. Remove the boot media from the controller module:

- a. Using a #1 Phillips head screwdriver, remove the screw holding down the boot media and set the screw aside in a safe place.
- b. Grasping the sides of the boot media, gently rotate the boot media up, and then pull the boot media straight out of the socket and set it aside.

3. Move the boot media to the new controller module and install it:

- a. Align the edges of the boot media with the socket housing, and then gently push it squarely into the socket.
- b. Rotate the boot media down toward the motherboard.
- c. Secure the boot media to the motherboard using the boot media screw.

Do not over-tighten the screw or you might damage the boot media.

## Step 9: Install the PCIe risers

You install the PCIe risers in the replacement controller module after moving the DIMMs, NVDIMMs, and boot media.

1. Install the riser into the replacement controller module:
  - a. Align the lip of the riser with the underside of the controller module sheet metal.
  - b. Guide the riser along the pins in the controller module, and then lower the riser into the controller module.
  - c. Swing the locking latch down and click it into the locked position.

When locked, the locking latch is flush with the top of the riser and the riser sits squarely in the controller module.

- d. Reinsert any SFP or QSFP modules that were removed from the PCIe cards.
2. Repeat the preceding step for the remaining PCIe risers.

## Step 10: Install the controller module

After all of the components have been moved from the impaired controller module to the replacement controller module, you must install the replacement controller module into the chassis and then boot it to Maintenance mode.

1. If you have not already done so, close the air duct:
  - a. Swing the air duct all the way down to the controller module.
  - b. Slide the air duct toward the risers until the locking tabs click into place.
  - c. Inspect the air duct to make sure that it is properly seated and locked into place.

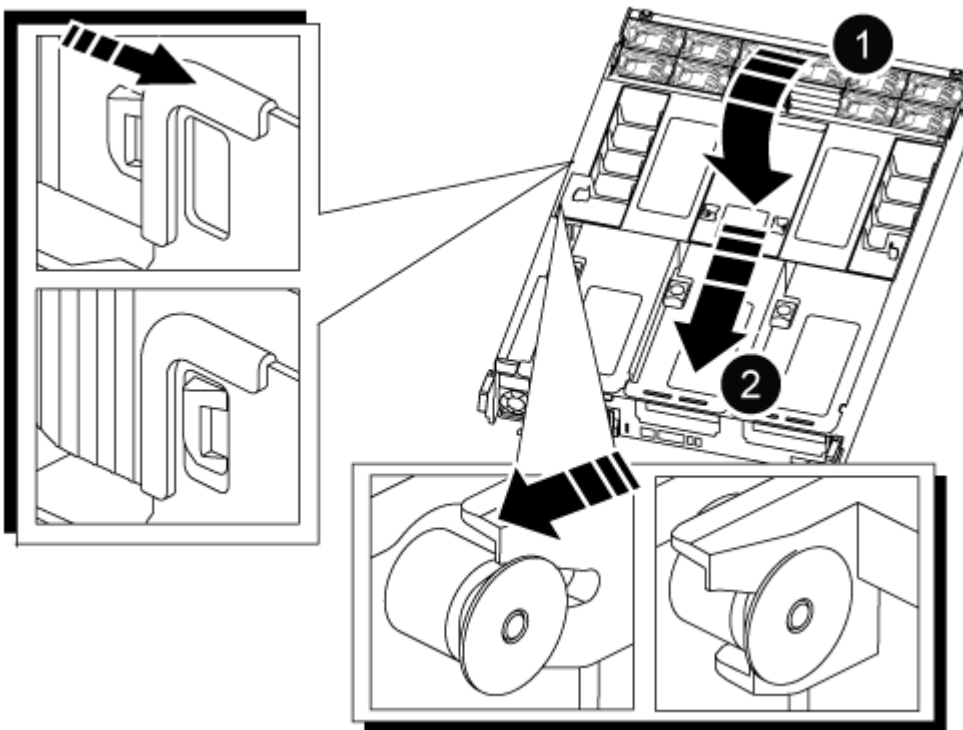

<b>1</b>	Locking tabs
<b>2</b>	Slide plunger

2. Align the end of the controller module with the opening in the chassis, and then gently push the controller module halfway into the system.



Do not completely insert the controller module in the chassis until instructed to do so.

3. Cable the management and console ports only, so that you can access the system to perform the tasks in the following sections.



You will connect the rest of the cables to the controller module later in this procedure.

4. Complete the reinstallation of the controller module:

a. Firmly push the controller module into the chassis until it meets the midplane and is fully seated.

The locking latches rise when the controller module is fully seated.



Do not use excessive force when sliding the controller module into the chassis to avoid damaging the connectors.

b. Rotate the locking latches upward, tilting them so that they clear the locking pins, and then lower them into the locked position.

5. Plug the system cables and transceiver modules into the controller module and reinstall the cable management device.

6. Plug the power cables into the power supplies and reinstall the power cable retainers.

The controller module begins to boot as soon as it is connected to power. Be prepared to interrupt the boot process.



If your system has DC power supplies, make sure the thumbscrews on the power supply cable are tight.

## Restore and verify the system configuration - ASA A800

After completing the hardware replacement and booting to Maintenance mode, you verify the low-level system configuration of the replacement controller and reconfigure system settings as necessary.

### Step 1: Set and verify system time

You should check the time and date on the replacement controller module against the healthy controller module in an HA pair, or against a reliable time server in a stand-alone configuration. If the time and date do not match, you must reset them on the replacement controller module to prevent possible outages on clients due to time differences.



## About this task

It is important that you apply the commands in the steps on the correct systems:

- The *replacement* node is the new node that replaced the impaired node as part of this procedure.
- The *healthy* node is the HA partner of the *replacement* node.

## Steps

1. If the *replacement* node is not at the LOADER prompt, halt the system to the LOADER prompt.
2. On the *healthy* node, check the system time: `cluster date show`

The date and time are based on the configured timezone.

3. At the LOADER prompt, check the date and time on the *replacement* node: `show date`

The date and time are given in GMT.

4. If necessary, set the date in GMT on the replacement node: `set date mm/dd/yyyy`

5. If necessary, set the time in GMT on the replacement node: `set time hh:mm:ss`

6. At the LOADER prompt, confirm the date and time on the *replacement* node: `show date`

The date and time are given in GMT.

## Step 2: Verify and set the HA state of the chassis

You must verify the HA state of the controller module and, if necessary, update the state to match your system configuration.

1. In Maintenance mode from the new controller module, verify that all components display the same HA state: `ha-config show`

The HA state should be the same for all components.

2. If the displayed system state of the controller module does not match your system configuration, set the HA state for the controller module: `ha-config modify controller ha-state`

The value for HA-state can be one of the following:

- `ha`
- `mcc`
- `mccip`
- `non-ha`

3. If the displayed system state of the controller module does not match your system configuration, set the HA state for the controller module: `ha-config modify controller ha-state`

4. Confirm that the setting has changed: `ha-config show`

## Recable the system and reassign disks - ASA A800

Continue the replacement procedure by recabling the storage and confirming disk reassignment.

### Step 1: Recable the system

Recable the controller module's storage and network connections.

#### Steps

1. Recable the the controller module to storage and network connections.
2. Verify that the cabling is correct by using [Active IQ Config Advisor](#).
  - a. Download and install Config Advisor.
  - b. Enter the information for the target system, and then click Collect Data.
  - c. Click the Cabling tab, and then examine the output. Make sure that all disk shelves are displayed and all disks appear in the output, correcting any cabling issues you find.
  - d. Check other cabling by clicking the appropriate tab, and then examining the output from Config Advisor.

### Step 2: Reassign disks

If the storage system is in an HA pair, the system ID of the new controller module is automatically assigned to the disks when the giveback occurs at the end of the procedure. You must confirm the system ID change when you boot the *replacement* controller and then verify that the change was implemented.

This procedure applies only to systems running ONTAP in an HA pair.

1. If the *replacement* controller is in Maintenance mode (showing the `*>` prompt, exit Maintenance mode and go to the LOADER prompt: `halt`
2. From the LOADER prompt on the *replacement* controller, boot the controller, entering `y` if you are prompted to override the system ID due to a system ID mismatch: `boot_ontap`
3. Wait until the `Waiting for giveback...` message is displayed on the *replacement* controller console and then, from the healthy controller, verify that the new partner system ID has been automatically assigned: `storage failover show`

In the command output, you should see a message that the system ID has changed on the impaired controller, showing the correct old and new IDs. In the following example, node2 has undergone replacement and has a new system ID of 151759706.

```

node1> `storage failover show`
Node                Partner                Takeover
-----            -
node1                node2                false
partner (Old:
151759706), In takeover
node2                node1                -
(HA mailboxes)
State Description
System ID changed on
151759755, New:
Waiting for giveback

```

4. From the healthy controller, verify that any coredumps are saved:

- a. Change to the advanced privilege level: `set -privilege advanced`

You can respond `y` when prompted to continue into advanced mode. The advanced mode prompt appears (`*>`).

- b. Save any coredumps: `system node run -node local-node-name partner savecore`

- c. Wait for the `savecore` command to complete before issuing the giveback.

You can enter the following command to monitor the progress of the `savecore` command: `system node run -node local-node-name partner savecore -s`

- d. Return to the admin privilege level: `set -privilege admin`

5. If your storage system has Storage or Volume Encryption configured, you must restore Storage or Volume Encryption functionality by using one of the following procedures, depending on whether you are using onboard or external key management:

- [Restore onboard key management encryption keys](#)
- [Restore external key management encryption keys](#)

6. Give back the controller:

- a. From the healthy controller, give back the replaced controller's storage: `storage failover giveback -ofnode replacement_node_name`

The *replacement* controller takes back its storage and completes booting.

If you are prompted to override the system ID due to a system ID mismatch, you should enter `y`.



If the giveback is vetoed, you can consider overriding the vetoes.

[Find the High-Availability Configuration content for your version of ONTAP 9](#)

- b. After the giveback has been completed, confirm that the HA pair is healthy and that takeover is possible: `storage failover show`

The output from the `storage failover show` command should not include the System ID changed

on partner message.

7. Verify that the disks were assigned correctly: `storage disk show -ownership`

The disks belonging to the *replacement* controller should show the new system ID. In the following example, the disks owned by node1 now show the new system ID, 1873775277:

```
node1> `storage disk show -ownership`

Disk Aggregate Home Owner DR Home Home ID Owner ID DR Home ID
Reserver Pool
-----
-----
-----
-----
1.0.0 aggr0_1 node1 node1 - 1873775277 1873775277 -
1873775277 Pool0
1.0.1 aggr0_1 node1 node1 1873775277 1873775277 -
1873775277 Pool0
.
.
.
```

8. If the system is in a MetroCluster configuration, monitor the status of the controller: `metrocluster node show`

The MetroCluster configuration takes a few minutes after the replacement to return to a normal state, at which time each controller will show a configured state, with DR Mirroring enabled and a mode of normal. The `metrocluster node show -fields node-systemid` command output displays the old system ID until the MetroCluster configuration returns to a normal state.

9. If the controller is in a MetroCluster configuration, depending on the MetroCluster state, verify that the DR home ID field shows the original owner of the disk if the original owner is a controller on the disaster site.

This is required if both of the following are true:

- The MetroCluster configuration is in a switchover state.
- The *replacement* controller is the current owner of the disks on the disaster site.

[Disk ownership changes during HA takeover and MetroCluster switchover in a four-node MetroCluster configuration](#)

10. If your system is in a MetroCluster configuration, verify that each controller is configured: `metrocluster node show - fields configuration-state`

```

node1_siteA::> metrocluster node show -fields configuration-state

dr-group-id          cluster node          configuration-state
-----
-----
1 node1_siteA        node1mcc-001         configured
1 node1_siteA        node1mcc-002         configured
1 node1_siteB        node1mcc-003         configured
1 node1_siteB        node1mcc-004         configured

4 entries were displayed.

```

11. Verify that the expected volumes are present for each controller: `vol show -node node-name`
12. If you disabled automatic takeover on reboot, enable it from the healthy controller: `storage failover modify -node replacement-node-name -onreboot true`

### Complete system restoration - ASA A800

To restore your system to full operation, you must restore the NetApp Storage Encryption configuration (if necessary), and install licenses for the new controller, and return the failed part to NetApp, as described in the RMA instructions shipped with the kit.

#### Step 1: Install licenses for the replacement controller in ONTAP

You must install new licenses for the *replacement* node if the impaired node was using ONTAP features that require a standard (node-locked) license. For features with standard licenses, each node in the cluster should have its own key for the feature.

#### About this task

Until you install license keys, features requiring standard licenses continue to be available to the *replacement* node. However, if the impaired node was the only node in the cluster with a license for the feature, no configuration changes to the feature are allowed. Also, using unlicensed features on the node might put you out of compliance with your license agreement, so you should install the replacement license key or keys on the *replacement* node as soon as possible.

#### Before you begin

The licenses keys must be in the 28-character format.

You have a 90-day grace period in which to install the license keys. After the grace period, all old licenses are invalidated. After a valid license key is installed, you have 24 hours to install all of the keys before the grace period ends.

#### Steps

1. If you need new license keys, obtain replacement license keys on the [NetApp Support Site](#) in the My Support section under Software licenses.



The new license keys that you require are automatically generated and sent to the email address on file. If you fail to receive the email with the license keys within 30 days, you should contact technical support.

2. Install each license key: `system license add -license-code license-key, license-key...`
3. Remove the old licenses, if desired:
  - a. Check for unused licenses: `license clean-up -unused -simulate`
  - b. If the list looks correct, remove the unused licenses: `license clean-up -unused`

## Step 2: Verify LIFs and registering the serial number

Before returning the *replacement* node to service, you should verify that the LIFs are on their home ports, and register the serial number of the *replacement* node if AutoSupport is enabled, and reset automatic giveback.

### Steps

1. Verify that the logical interfaces are reporting to their home server and ports: `network interface show -is-home false`  
  
If any LIFs are listed as false, revert them to their home ports: `network interface revert -vserver * -lif *`
2. Register the system serial number with NetApp Support.
  - If AutoSupport is enabled, send an AutoSupport message to register the serial number.
  - If AutoSupport is not enabled, call [NetApp Support](#) to register the serial number.
3. If an AutoSupport maintenance window was triggered, end it by using the `system node autosupport invoke -node * -type all -message MAINT=END` command.
4. If automatic giveback was disabled, reenable it: `storage failover modify -node local -auto-giveback true`

## Step 3: Return the failed part to NetApp

Return the failed part to NetApp, as described in the RMA instructions shipped with the kit. See the [Part Return and Replacements](#) page for further information.

### Replace DIMM - ASA A800

You must replace a DIMM in the controller module when your system registers an increasing number of correctable error correction codes (ECC); failure to do so causes a system panic.

All other components in the system must be functioning properly; if not, you must contact technical support.

You must replace the failed component with a replacement FRU component you received from your provider.

## Step 1: Shut down the impaired controller

Recable the controller module's storage and network connections.

### Steps

1. Recable the the controller module to storage and network connections.
2. Verify that the cabling is correct by using [Active IQ Config Advisor](#).
  - a. Download and install Config Advisor.
  - b. Enter the information for the target system, and then click Collect Data.
  - c. Click the Cabling tab, and then examine the output. Make sure that all disk shelves are displayed and all disks appear in the output, correcting any cabling issues you find.
  - d. Check other cabling by clicking the appropriate tab, and then examining the output from Config Advisor.

## Step 2: Remove the controller module

You must remove the controller module from the chassis when you replace the controller module or replace a component inside the controller module.

1. If you are not already grounded, properly ground yourself.
2. Unplug the controller module power supplies from the source.
3. Release the power cable retainers, and then unplug the cables from the power supplies.
4. Loosen the hook and loop strap binding the cables to the cable management device, and then unplug the system cables and SFP and QSFP modules (if needed) from the controller module, keeping track of where the cables were connected.

Leave the cables in the cable management device so that when you reinstall the cable management device, the cables are organized.

5. Remove the cable management device from the controller module and set it aside.
6. Press down on both of the locking latches, and then rotate both latches downward at the same time.

The controller module moves slightly out of the chassis.

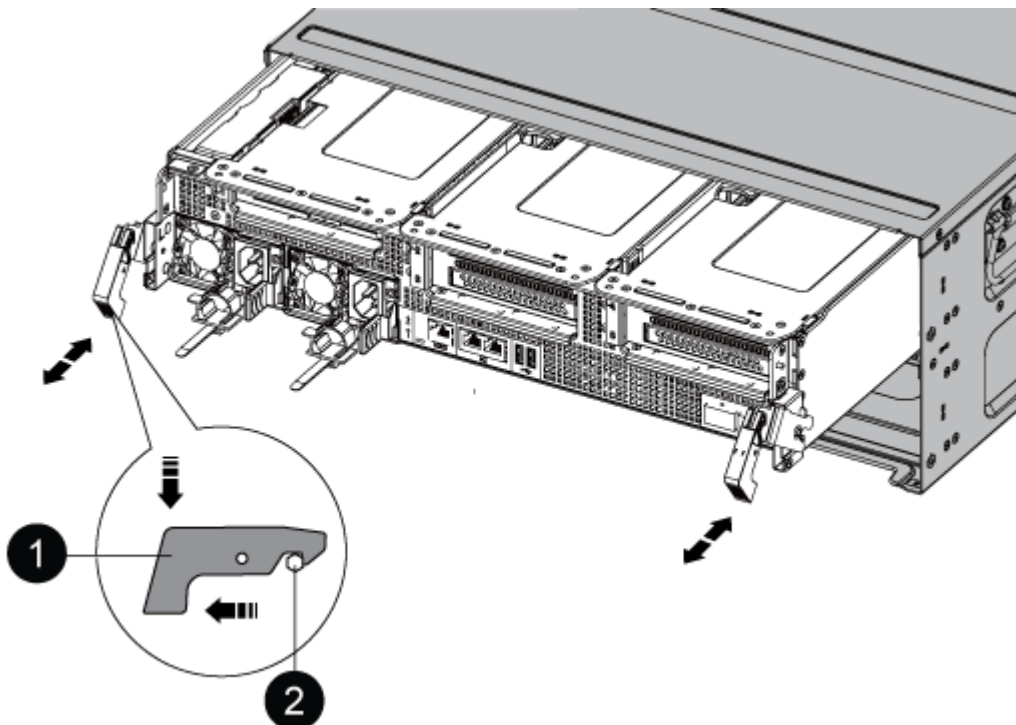

1	Locking latch
2	Locking pin

7. Slide the controller module out of the chassis.

Make sure that you support the bottom of the controller module as you slide it out of the chassis.

8. Place the controller module on a stable, flat surface, and then open the air duct:

- a. Press in the locking tabs on the sides of the air duct toward the middle of the controller module.
- b. Slide the air duct toward the fan modules, and then rotate it upward to its completely open position.

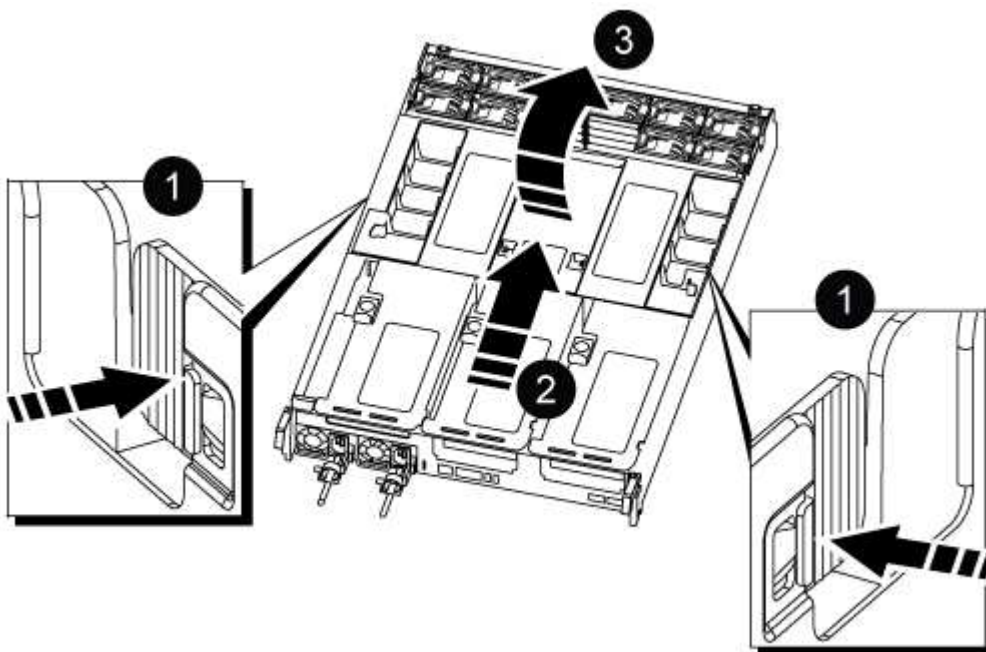

1	Air duct locking tabs
2	Slide air duct towards fan modules
3	Rotate air duct towards fan modules

### Step 3: Replace a DIMM

To replace a DIMM, you must locate it in the controller module using the DIMM map label on top of the air duct and then replace it following the specific sequence of steps.

1. When removing a DIMM, unlock the locking latch on the applicable riser, and then remove the riser.



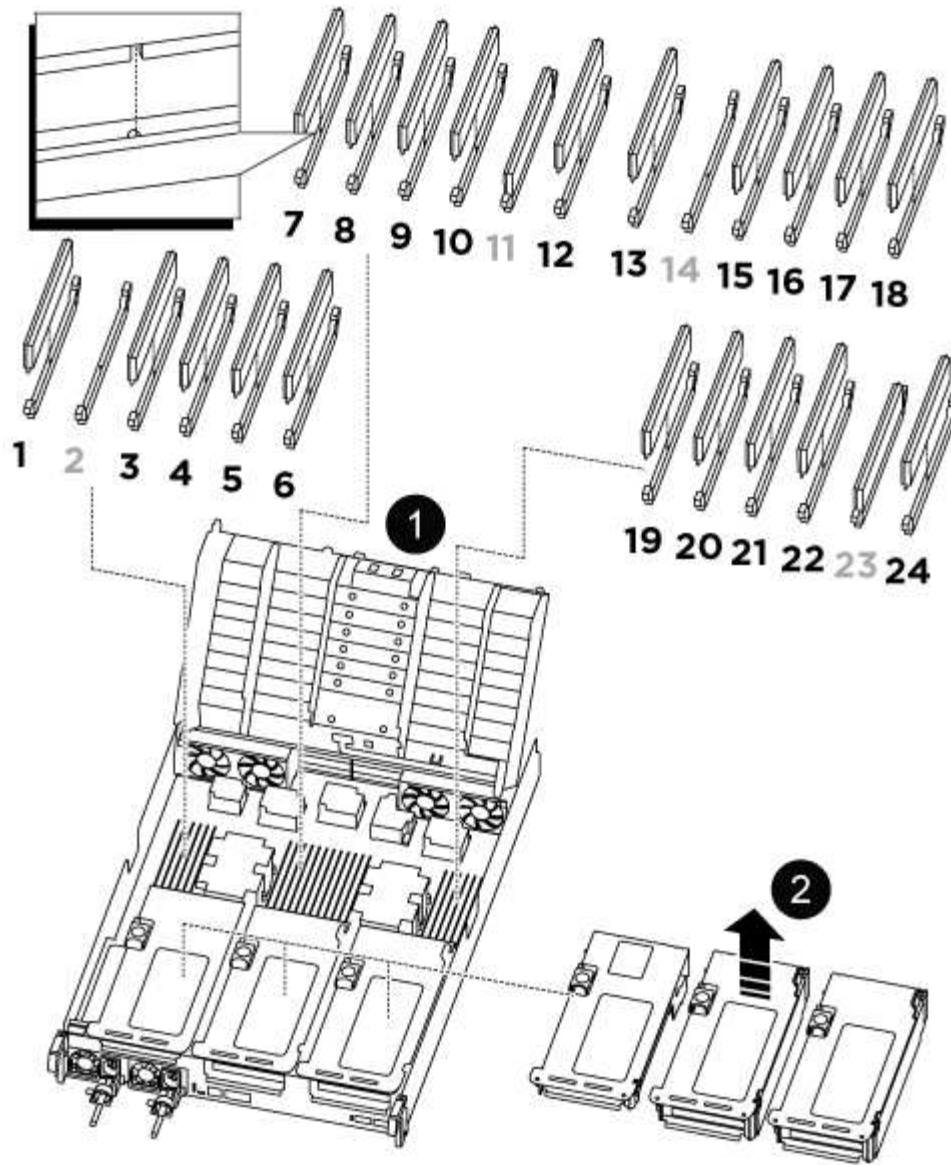

<p>1</p>	<p>Air duct cover</p>
<p>2</p>	<p>Riser 1 and DIMM bank 1, and 3-6</p>
<p>Riser 2 and DIMM bank 7-10, 12-13, and 15-18</p>	<p>Riser 3 and DIMM 19 -22 and 24</p>

**Note:** Slot 2 and 14 are left empty. Do not attempt to install DIMMs into these slots.

2. Note the orientation of the DIMM in the socket so that you can insert the replacement DIMM in the proper orientation.
3. Eject the DIMM from its slot by slowly pushing apart the two DIMM ejector tabs on either side of the DIMM, and then slide the DIMM out of the slot.



Carefully hold the DIMM by the edges to avoid pressure on the components on the DIMM circuit board.

4. Remove the replacement DIMM from the antistatic shipping bag, hold the DIMM by the corners, and align it to the slot.

The notch among the pins on the DIMM should line up with the tab in the socket.

5. Insert the DIMM squarely into the slot.

The DIMM fits tightly in the slot, but should go in easily. If not, realign the DIMM with the slot and reinsert it.



Visually inspect the DIMM to verify that it is evenly aligned and fully inserted into the slot.

6. Push carefully, but firmly, on the top edge of the DIMM until the ejector tabs snap into place over the notches at the ends of the DIMM.
7. Reinstall any risers that you removed from the controller module.
8. Close the air duct.

#### Step 4: Reinstall the controller module and booting the system

After you replace a FRU in the controller module, you must reinstall the controller module and reboot it.

1. If you have not already done so, close the air duct:
  - a. Swing the air duct all the way down to the controller module.
  - b. Slide the air duct toward the risers until the locking tabs click into place.
  - c. Inspect the air duct to make sure that it is properly seated and locked into place.

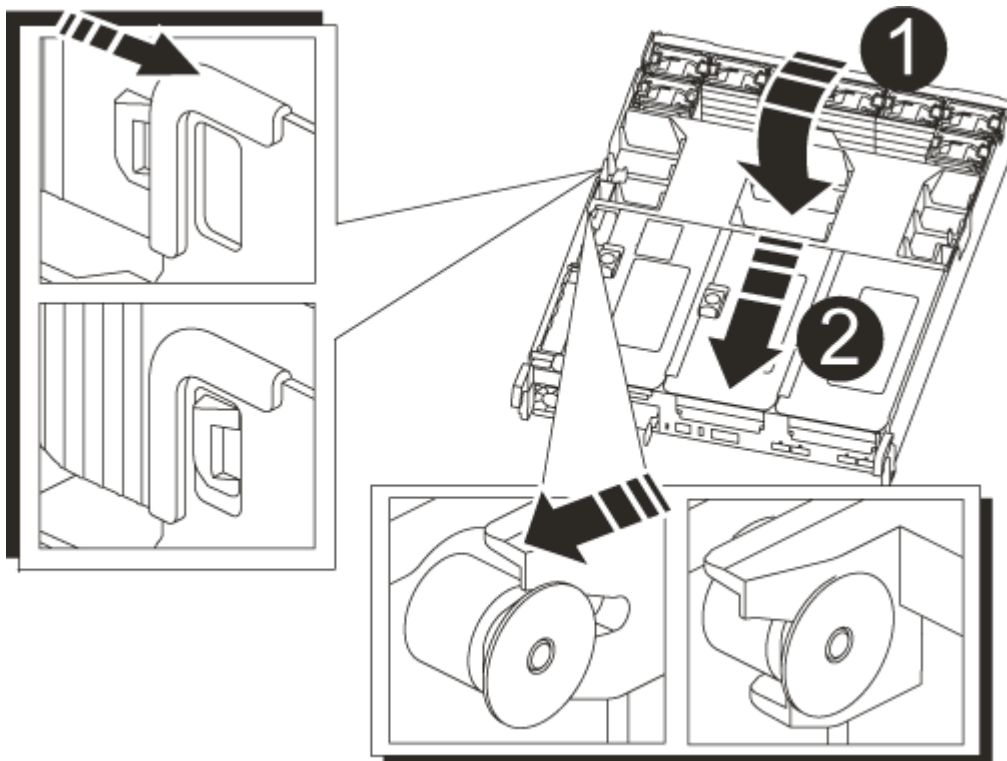

<b>1</b>	Locking tabs
<b>2</b>	Slide plunger

2. Align the end of the controller module with the opening in the chassis, and then gently push the controller module halfway into the system.



Do not completely insert the controller module in the chassis until instructed to do so.

3. Recable the system, as needed.

If you removed the media converters (QSFPs or SFPs), remember to reinstall them if you are using fiber optic cables.

4. Plug the power cord into the power supply, reinstall the power cable locking collar, and then connect the power supply to the power source.

5. Complete the reinstallation of the controller module:

- a. Firmly push the controller module into the chassis until it meets the midplane and is fully seated.

The locking latches rise when the controller module is fully seated.



Do not use excessive force when sliding the controller module into the chassis to avoid damaging the connectors.

The controller module begins to boot as soon as it is fully seated in the chassis.

- b. Rotate the locking latches upward, tilting them so that they clear the locking pins, and then lower them into the locked position.
- c. If you have not already done so, reinstall the cable management device.

### Step 5: Return the failed part to NetApp

Return the failed part to NetApp, as described in the RMA instructions shipped with the kit. See the [Part Return and Replacements](#) page for further information.

#### Replace SSD Drive or HDD Drive - ASA A800

You can replace a failed drive nondisruptively while I/O is in progress. The procedure for replacing an SSD is meant for non-spinning drives and the procedure for replacing an HDD is meant for spinning drives.

When a drive fails, the platform logs a warning message to the system console indicating which drive has failed. In addition, both the fault LED on the operator display panel and the fault LED on the failed drive are illuminated.

#### Before you begin

- Follow best practice and install the current version of the Disk Qualification Package (DQP) before replacing a drive.

- Identify the failed drive by running the `storage disk show -broken` command from the system console.

The failed drive appears in the list of failed drives. If it does not, you should wait, and then run the command again.



Depending on the type and capacity, it can take up to several hours for the drive to appear in the list of failed drives.

- Determine whether SED authentication is enabled.

How you replace the drive depends on how the drive is being used. If SED authentication is enabled, you must use the SED replacement instructions in the [ONTAP 9 NetApp Encryption Power Guide](#). These Instructions describe additional steps you must perform before and after replacing an SED.

- Make sure the replacement drive is supported by your platform. See the [NetApp Hardware Universe](#).
- Make sure all other components in the system are functioning properly; if not, you must contact technical support.

#### **About this task**

- Drive firmware is automatically updated (nondisruptively) on new drives that have non current firmware versions.
- When replacing a drive, you must wait one minute between the removal of the failed drive and the insertion of the replacement drive to allow the storage system to recognize the existence of the new drive.

## Option 1: Replace SSD

### Steps

1. If you want to manually assign drive ownership for the replacement drive, you need to disable automatic drive assignment replacement drive, if it is enabled



You manually assign drive ownership and then reenables automatic drive assignment later in this procedure.

- a. Verify whether automatic drive assignment is enabled: `storage disk option show`

You can enter the command on either controller module.

If automatic drive assignment is enabled, the output shows `on` in the “Auto Assign” column (for each controller module).

- b. If automatic drive assignment is enabled, disable it: `storage disk option modify -node node_name -autoassign off`

You must disable automatic drive assignment on both controller modules.

2. Properly ground yourself.
3. Physically identify the failed drive.

When a drive fails, the system logs a warning message to the system console indicating which drive failed. Additionally, the attention (amber) LED on the drive shelf operator display panel and the failed drive illuminate.



The activity (green) LED on a failed drive can be illuminated (solid), which indicates that the drive has power, but should not be blinking, which indicates I/O activity. A failed drive has no I/O activity.

4. Remove the failed drive:
  - a. Press the release button on the drive face to open the cam handle.
  - b. Slide the drive out of the shelf using the cam handle and supporting the drive with your other hand.

5. Wait a minimum of 70 seconds before inserting the replacement drive.

This allows the system to recognize that a drive was removed.

6. Insert the replacement drive:
  - a. With the cam handle in the open position, use both hands to insert the replacement drive.
  - b. Push until the drive stops.
  - c. Close the cam handle so that the drive is fully seated into the midplane and the handle clicks into place.

Be sure to close the cam handle slowly so that it aligns correctly with the face of the drive.

7. Verify that the drive’s activity (green) LED is illuminated.

When the drive's activity LED is solid, it means that the drive has power. When the drive's activity LED is blinking, it means that the drive has power and I/O is in progress. If the drive firmware is automatically updating, the LED blinks.

8. If you are replacing another drive, repeat Steps 3 through 7.
9. If you disabled automatic drive assignment in Step 1, then, manually assign drive ownership and then reenables automatic drive assignment if needed.

- a. Display all unowned drives: `storage disk show -container-type unassigned`

You can enter the command on either controller module.

- b. Assign each drive: `storage disk assign -disk disk_name -owner node_name`

You can enter the command on either controller module.

You can use the wildcard character to assign more than one drive at once.

- c. Reenable automatic drive assignment if needed: `storage disk option modify -node node_name -autoassign on`

You must reenables automatic drive assignment on both controller modules.

10. Return the failed part to NetApp, as described in the RMA instructions shipped with the kit.

Contact technical support at [NetApp Support](#), 888-463-8277 (North America), 00-800-44-638277 (Europe), or +800-800-80-800 (Asia/Pacific) if you need the RMA number or additional help with the replacement procedure.

## Option 2: Replace HDD

1. If you want to manually assign drive ownership for the replacement drive, you need to disable automatic drive assignment replacement drive, if it is enabled



You manually assign drive ownership and then reenables automatic drive assignment later in this procedure.

- a. Verify whether automatic drive assignment is enabled: `storage disk option show`

You can enter the command on either controller module.

If automatic drive assignment is enabled, the output shows `on` in the "Auto Assign" column (for each controller module).

- b. If automatic drive assignment is enabled, disable it: `storage disk option modify -node node_name -autoassign off`

You must disable automatic drive assignment on both controller modules.

2. Properly ground yourself.
3. Gently remove the bezel from the front of the platform.
4. Identify the failed disk drive from the system console warning message and the illuminated fault LED on the disk drive

5. Press the release button on the disk drive face.

Depending on the storage system, the disk drives have the release button located at the top or on the left of the disk drive face.

For example, the following illustration shows a disk drive with the release button located on the top of the disk drive face:

The cam handle on the disk drive springs open partially and the disk drive releases from the midplane.

6. Pull the cam handle to its fully open position to unseat the disk drive from the midplane.

7. Slide out the disk drive slightly and allow the disk to safely spin down, which can take less than one minute, and then, using both hands, remove the disk drive from the disk shelf.

8. With the cam handle in the open position, insert the replacement disk drive into the drive bay, firmly pushing until the disk drive stops.



Wait a minimum of 10 seconds before inserting a new disk drive. This allows the system to recognize that a disk drive was removed.



If your platform drive bays are not fully loaded with drives, it is important to place the replacement drive into the same drive bay from which you removed the failed drive.



Use two hands when inserting the disk drive, but do not place hands on the disk drive boards that are exposed on the underside of the disk carrier.

9. Close the cam handle so that the disk drive is fully seated into the midplane and the handle clicks into place.

Be sure to close the cam handle slowly so that it aligns correctly with the face of the disk drive..

10. If you are replacing another disk drive, repeat Steps 4 through 9.

11. Reinstall the bezel.

12. If you disabled automatic drive assignment in Step 1, then, manually assign drive ownership and then reenables automatic drive assignment if needed.

a. Display all unowned drives: `storage disk show -container-type unassigned`

You can enter the command on either controller module.

b. Assign each drive: `storage disk assign -disk disk_name -owner owner_name`

You can enter the command on either controller module.

You can use the wildcard character to assign more than one drive at once.

c. Reenable automatic drive assignment if needed: `storage disk option modify -node node_name -autoassign on`

You must reenable automatic drive assignment on both controller modules.

13. Return the failed part to NetApp, as described in the RMA instructions shipped with the kit.

Contact technical support at [NetApp Support](#), 888-463-8277 (North America), 00-800-44-638277 (Europe), or +800-800-80-800 (Asia/Pacific) if you need the RMA number or additional help with the replacement procedure.

## Replace a fan - ASA A800

To replace a fan, remove the failed fan module and replace it with a new fan module.

### Step 1: Shut down the impaired controller

To shut down the impaired controller, you must determine the status of the controller and, if necessary, take over the controller so that the healthy controller continues to serve data from the impaired controller storage.

#### About this task

- If you have a SAN system, you must have checked event messages (`cluster kernel-service show`) for the impaired controller SCSI blade. The `cluster kernel-service show` command (from `priv advanced` mode) displays the node name, quorum status of that node, availability status of that node, and operational status of that node.

Each SCSI-blade process should be in quorum with the other nodes in the cluster. Any issues must be resolved before you proceed with the replacement.

- If you have a cluster with more than two nodes, it must be in quorum. If the cluster is not in quorum or a healthy controller shows `false` for eligibility and health, you must correct the issue before shutting down the impaired controller; see [Synchronize a node with the cluster](#).

#### Steps

1. If AutoSupport is enabled, suppress automatic case creation by invoking an AutoSupport message:  

```
system node autosupport invoke -node * -type all -message MAINT=<# of hours>h
```

The following AutoSupport message suppresses automatic case creation for two hours: `cluster1:>`  

```
system node autosupport invoke -node * -type all -message MAINT=2h
```

2. Disable automatic giveback from the console of the healthy controller: 

```
storage failover modify -node local -auto-giveback false
```



When you see *Do you want to disable auto-giveback?*, enter `y`.

3. Take the impaired controller to the LOADER prompt:

If the impaired controller is displaying...	Then...
The LOADER prompt	Go to the next step.
Waiting for giveback...	Press Ctrl-C, and then respond <code>y</code> when prompted.



If the impaired controller is displaying...	Then...
System prompt or password prompt	<p>Take over or halt the impaired controller from the healthy controller:  <code>storage failover takeover -ofnode  impaired_node_name</code></p> <p>When the impaired controller shows Waiting for giveback..., press Ctrl-C, and then respond <i>y</i>.</p>

## Step 2: Remove the controller module

You must remove the controller module from the chassis when you replace a fan module.

1. If you are not already grounded, properly ground yourself.
2. Unplug the controller module power supplies from the source.
3. Release the power cable retainers, and then unplug the cables from the power supplies.
4. Loosen the hook and loop strap binding the cables to the cable management device, and then unplug the system cables from the controller module, keeping track of where the cables were connected.

Leave the cables in the cable management device so that when you reinstall the cable management device, the cables are organized.

5. Remove the cable management device from the controller module and set it aside.
6. Press down on both of the locking latches, and then rotate both latches downward at the same time.

The controller module moves slightly out of the chassis.

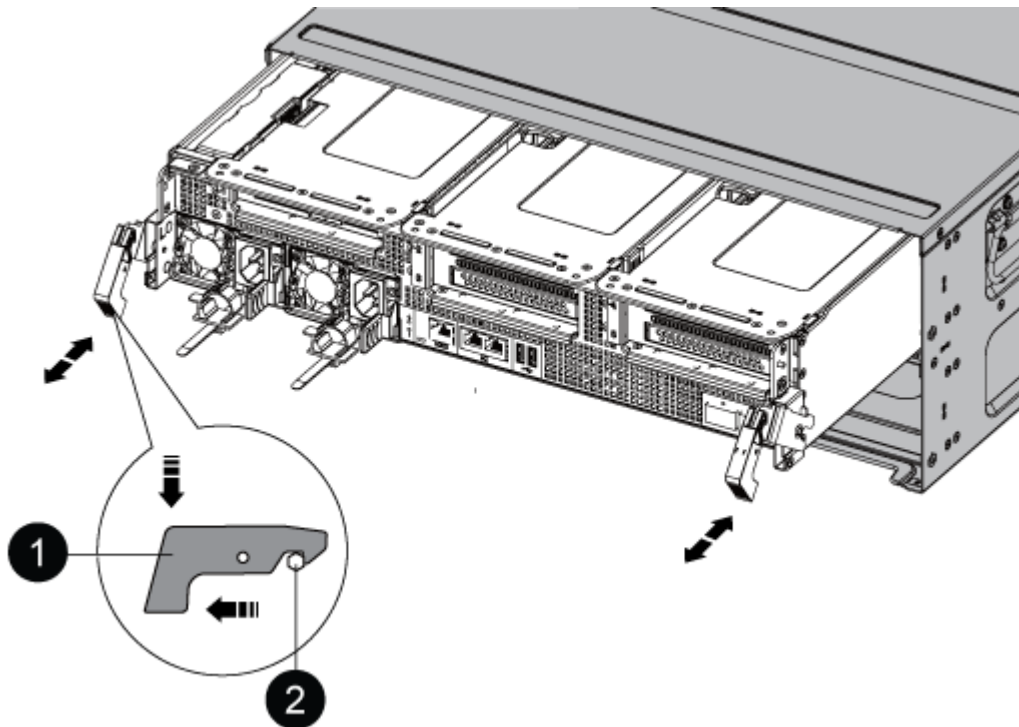

1	Locking latch
2	Locking pin

7. Slide the controller module out of the chassis.

Make sure that you support the bottom of the controller module as you slide it out of the chassis.

8. Set the controller module aside in a safe place.

### Step 3: Replace a fan

To replace a fan, remove the failed fan module and replace it with a new fan module.

1. Identify the fan module that you must replace by checking the console error messages or by locating the lit LED for the fan module on the motherboard.
2. Remove the fan module by pinching the locking tabs on the side of the fan module, and then lifting the fan module straight out of the controller module.

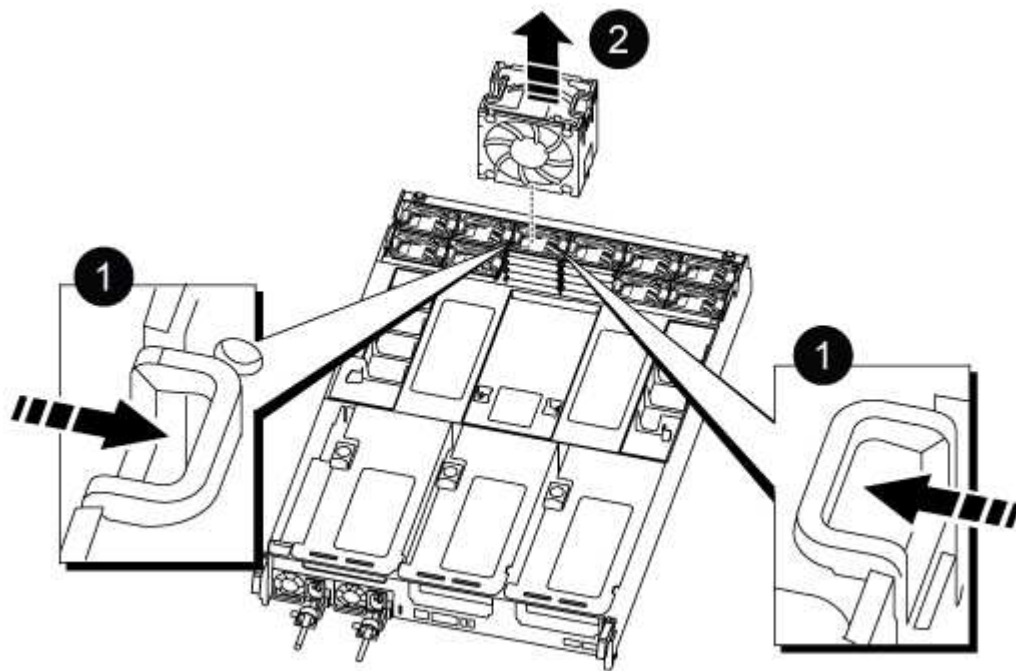

1	Fan locking tabs
2	Fan module

3. Align the edges of the replacement fan module with the opening in the controller module, and then slide the replacement fan module into the controller module until the locking latches click into place.

## Step 4: Reinstall the controller module

After you replace a component within the controller module, you must reinstall the controller module in the system chassis and boot it.

1. Align the end of the controller module with the opening in the chassis, and then gently push the controller module halfway into the system.



Do not completely insert the controller module in the chassis until instructed to do so.

2. Recable the system, as needed.
3. Plug the power cables into the power supplies and reinstall the power cable retainers.
4. Complete the reinstallation of the controller module:
  - a. Firmly push the controller module into the chassis until it meets the midplane and is fully seated.

The locking latches rise when the controller module is fully seated.



Do not use excessive force when sliding the controller module into the chassis to avoid damaging the connectors.

The controller module begins to boot as soon as it is fully seated in the chassis.

- b. Rotate the locking latches upward, tilting them so that they clear the locking pins, and then lower them into the locked position.
  - c. If you have not already done so, reinstall the cable management device.
5. Return the controller to normal operation by giving back its storage: `storage failover giveback -ofnode impaired_node_name`
6. If automatic giveback was disabled, reenable it: `storage failover modify -controller local -auto-giveback true`

## Step 5: Return the failed part to NetApp

Return the failed part to NetApp, as described in the RMA instructions shipped with the kit. See the [Part Return and Replacements](#) page for further information.

### Replace an NVDIMM - ASA A800

You must replace the NVDIMM in the controller module when your system registers that the flash lifetime is almost at an end or that the identified NVDIMM is not healthy in general; failure to do so causes a system panic.

All other components in the system must be functioning properly; if not, you must contact technical support.

You must replace the failed component with a replacement FRU component you received from your provider.

### Step 1: Shut down the impaired controller

To shut down the impaired controller, you must determine the status of the controller and, if necessary, take over the controller so that the healthy controller continues to serve data from the impaired controller storage.

## About this task

- If you have a SAN system, you must have checked event messages (`cluster kernel-service show`) for the impaired controller SCSI blade. The `cluster kernel-service show` command (from `priv advanced mode`) displays the node name, quorum status of that node, availability status of that node, and operational status of that node.

Each SCSI-blade process should be in quorum with the other nodes in the cluster. Any issues must be resolved before you proceed with the replacement.

- If you have a cluster with more than two nodes, it must be in quorum. If the cluster is not in quorum or a healthy controller shows `false` for eligibility and health, you must correct the issue before shutting down the impaired controller; see [Synchronize a node with the cluster](#).

## Steps

1. If AutoSupport is enabled, suppress automatic case creation by invoking an AutoSupport message:  
`system node autosupport invoke -node * -type all -message MAINT=<# of hours>h`

The following AutoSupport message suppresses automatic case creation for two hours: `cluster1:> system node autosupport invoke -node * -type all -message MAINT=2h`

2. Disable automatic giveback from the console of the healthy controller: `storage failover modify -node local -auto-giveback false`



When you see *Do you want to disable auto-giveback?*, enter *y*.

3. Take the impaired controller to the LOADER prompt:

If the impaired controller is displaying...	Then...
The LOADER prompt	Go to the next step.
Waiting for giveback...	Press Ctrl-C, and then respond <i>y</i> when prompted.
System prompt or password prompt	Take over or halt the impaired controller from the healthy controller: <code>storage failover takeover -ofnode impaired_node_name</code>  When the impaired controller shows Waiting for giveback..., press Ctrl-C, and then respond <i>y</i> .

## Step 2: Remove the controller module

You must remove the controller module from the chassis when you replace the controller module or replace a component inside the controller module.

1. If you are not already grounded, properly ground yourself.
2. Unplug the controller module power supplies from the source.
3. Release the power cable retainers, and then unplug the cables from the power supplies.

- Loosen the hook and loop strap binding the cables to the cable management device, and then unplug the system cables and SFP and QSFP modules (if needed) from the controller module, keeping track of where the cables were connected.

Leave the cables in the cable management device so that when you reinstall the cable management device, the cables are organized.

- Remove the cable management device from the controller module and set it aside.
- Press down on both of the locking latches, and then rotate both latches downward at the same time.

The controller module moves slightly out of the chassis.

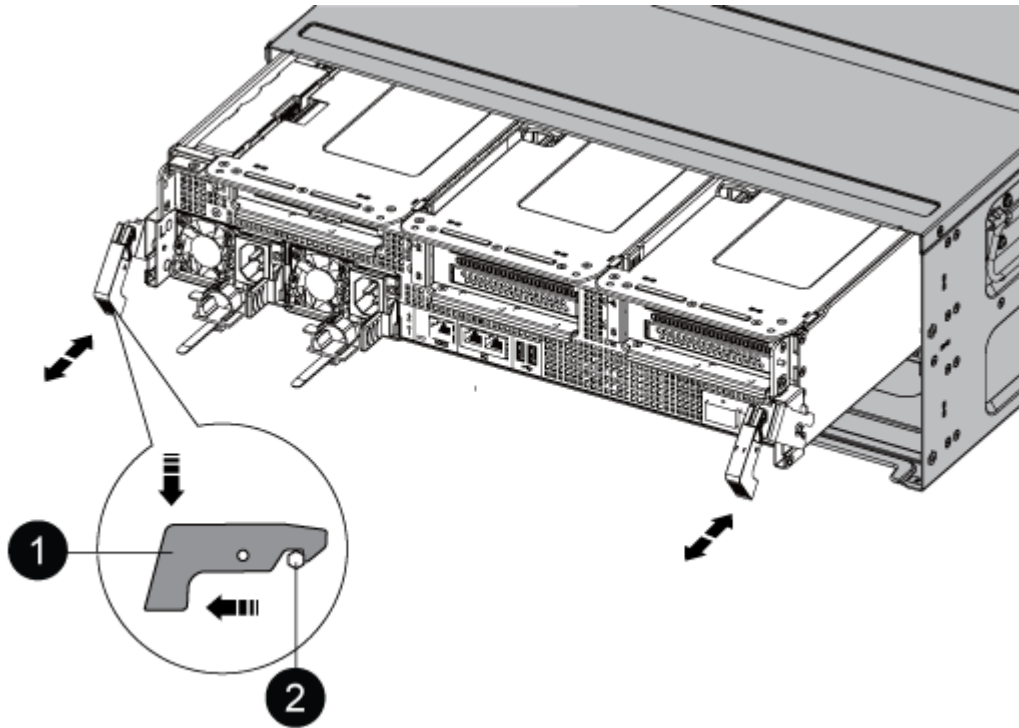

1	Locking latch
2	Locking pin

- Slide the controller module out of the chassis.

Make sure that you support the bottom of the controller module as you slide it out of the chassis.

- Place the controller module on a stable, flat surface, and then open the air duct:
  - Press in the locking tabs on the sides of the air duct toward the middle of the controller module.
  - Slide the air duct toward the fan modules, and then rotate it upward to its completely open position.

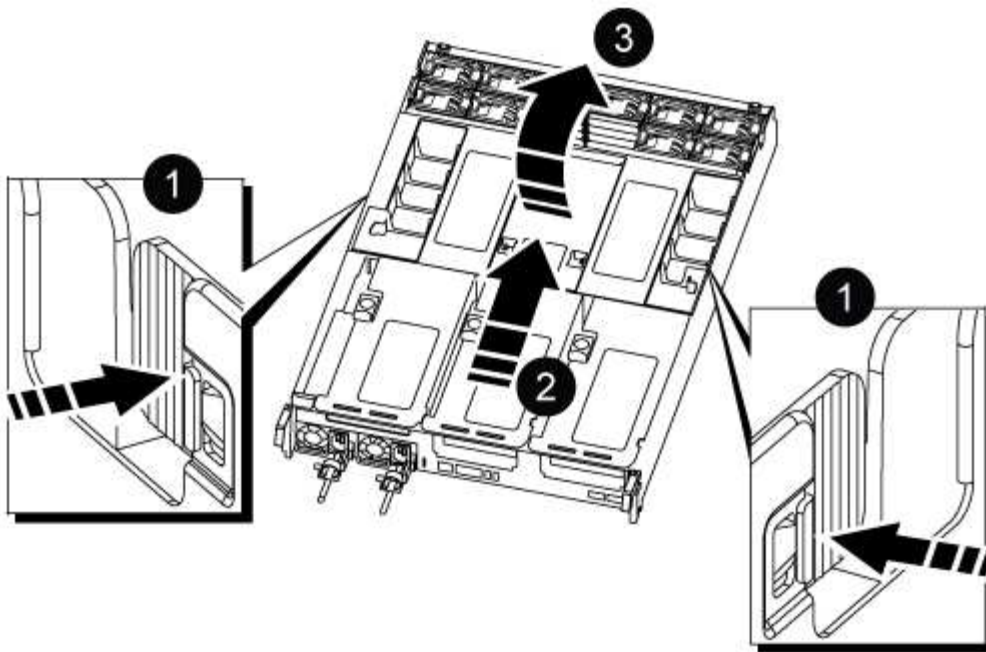

1	Air duct locking tabs
2	Slide air duct towards fan modules
3	Rotate air duct towards fan modules

### Step 3: Replace the NVDIMM

To replace the NVDIMM, you must locate it in the controller module using the NVDIMM map label on top of the air duct, and then replace it following the specific sequence of steps.

1. If you are removing or moving an NVDIMM, unlock the locking latch on the riser, and then remove the applicable riser.

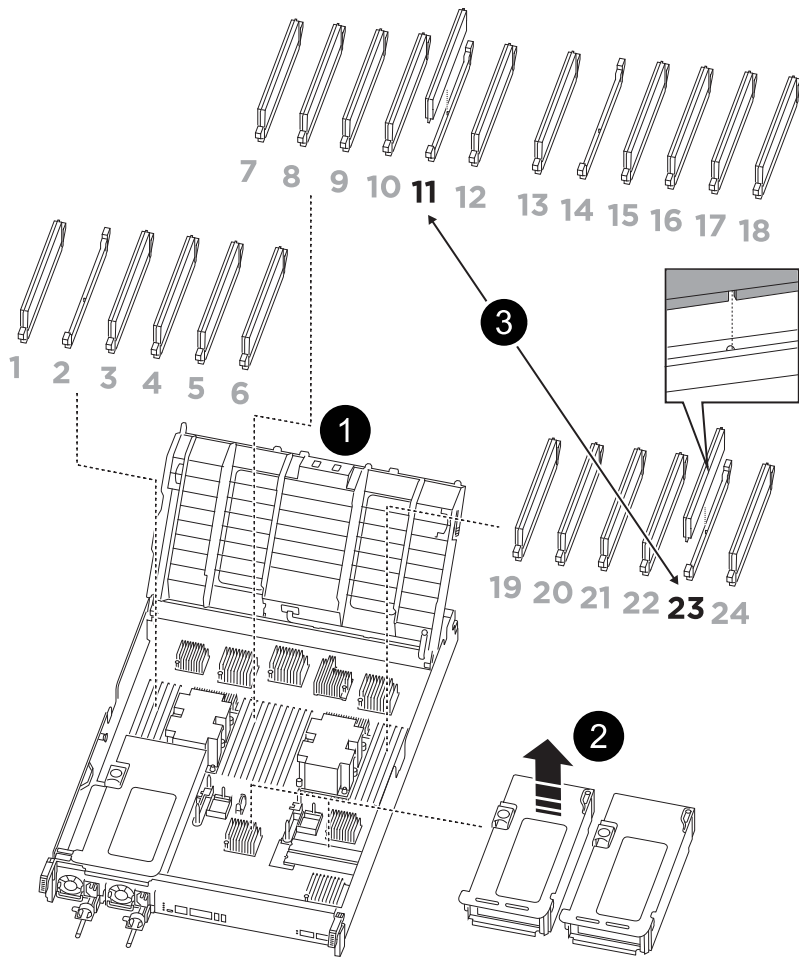

1	Air duct cover
2	Riser 2
3	NVDIMM in slots 11 and 23

2. Note the orientation of the NVDIMM in the socket so that you can insert the NVDIMM in the replacement controller module in the proper orientation.
3. Eject the NVDIMM from its slot by slowly pushing apart the two NVDIMM ejector tabs on either side of the NVDIMM, and then slide the NVDIMM out of the socket and set it aside.



Carefully hold the NVDIMM by the edges to avoid pressure on the components on the NVDIMM circuit board.

4. Remove the replacement NVDIMM from the antistatic shipping bag, hold the NVDIMM by the corners, and then align it to the slot.

The notch among the pins on the NVDIMM should line up with the tab in the socket.

5. Locate the slot where you are installing the NVDIMM.

6. Insert the NVDIMM squarely into the slot.

The NVDIMM fits tightly in the slot, but should go in easily. If not, realign the NVDIMM with the slot and reinsert it.



Visually inspect the NVDIMM to verify that it is evenly aligned and fully inserted into the slot.

7. Push carefully, but firmly, on the top edge of the NVDIMM until the ejector tabs snap into place over the notches at the ends of the NVDIMM.

8. Reinstall any risers that you removed from the controller module.

9. Close the air duct.

#### Step 4: Reinstall the controller module and booting the system

After you replace a FRU in the controller module, you must reinstall the controller module and reboot it.

1. If you have not already done so, close the air duct:

- a. Swing the air duct all the way down to the controller module.
- b. Slide the air duct toward the risers until the locking tabs click into place.
- c. Inspect the air duct to make sure that it is properly seated and locked into place.

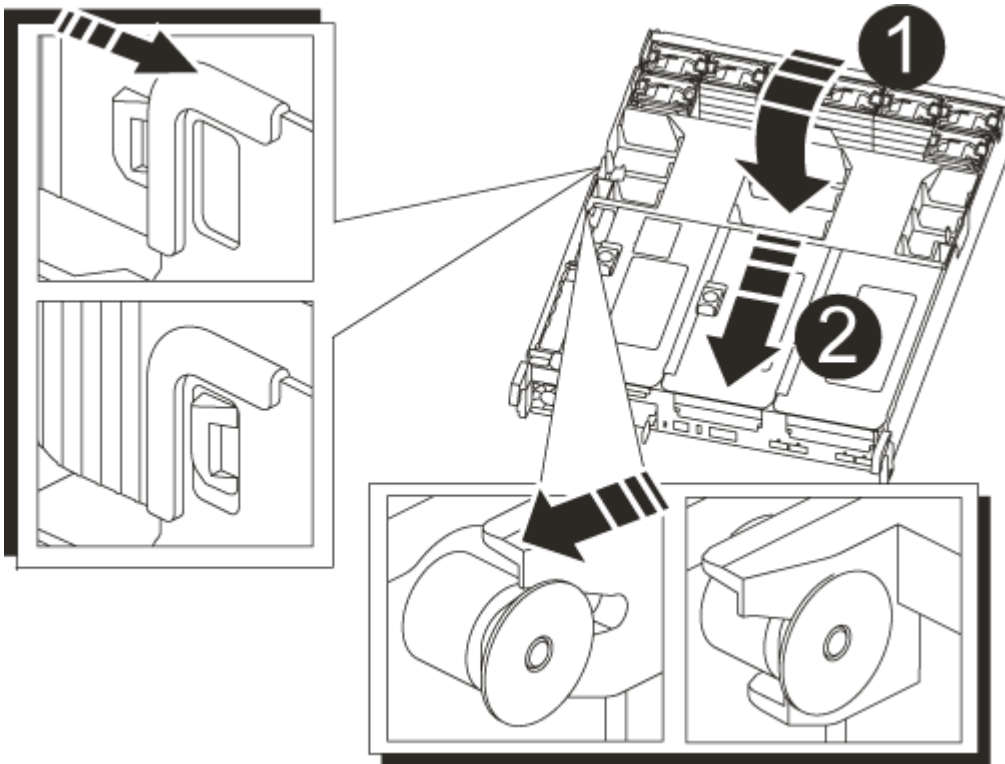

	Locking tabs
	Slide plunger



2. Align the end of the controller module with the opening in the chassis, and then gently push the controller module halfway into the system.



Do not completely insert the controller module in the chassis until instructed to do so.

3. Recable the system, as needed.

If you removed the media converters (QSFPs or SFPs), remember to reinstall them if you are using fiber optic cables.

4. Plug the power cord into the power supply, reinstall the power cable locking collar, and then connect the power supply to the power source.
5. Complete the reinstallation of the controller module:
  - a. Firmly push the controller module into the chassis until it meets the midplane and is fully seated.

The locking latches rise when the controller module is fully seated.



Do not use excessive force when sliding the controller module into the chassis to avoid damaging the connectors.

The controller module begins to boot as soon as it is fully seated in the chassis.

- b. Rotate the locking latches upward, tilting them so that they clear the locking pins, and then lower them into the locked position.
- c. If you have not already done so, reinstall the cable management device.

#### Step 4: Return the failed part to NetApp

Return the failed part to NetApp, as described in the RMA instructions shipped with the kit. See the [Part Return and Replacements](#) page for further information.

#### Replace the NVDIMM battery - ASA A800

To replace the NVDIMM battery, you must remove the controller module, remove the battery, replace the battery, and then reinstall the controller module.

All other components in the system must be functioning properly; if not, you must contact technical support.

#### Step 1: Shut down the impaired controller

To shut down the impaired controller, you must determine the status of the controller and, if necessary, take over the controller so that the healthy controller continues to serve data from the impaired controller storage.

#### About this task

- If you have a SAN system, you must have checked event messages (`cluster kernel-service show`) for the impaired controller SCSI blade. The `cluster kernel-service show` command (from `priv advanced mode`) displays the node name, quorum status of that node, availability status of that node, and operational status of that node.

Each SCSI-blade process should be in quorum with the other nodes in the cluster. Any issues must be resolved before you proceed with the replacement.

- If you have a cluster with more than two nodes, it must be in quorum. If the cluster is not in quorum or a healthy controller shows false for eligibility and health, you must correct the issue before shutting down the impaired controller; see [Synchronize a node with the cluster](#).

## Steps

1. If AutoSupport is enabled, suppress automatic case creation by invoking an AutoSupport message:  

```
system node autosupport invoke -node * -type all -message MAINT=<# of hours>h
```

The following AutoSupport message suppresses automatic case creation for two hours: `cluster1:>`  

```
system node autosupport invoke -node * -type all -message MAINT=2h
```

2. Disable automatic giveback from the console of the healthy controller: `storage failover modify -node local -auto-giveback false`



When you see *Do you want to disable auto-giveback?*, enter `y`.

3. Take the impaired controller to the LOADER prompt:

If the impaired controller is displaying...	Then...
The LOADER prompt	Go to the next step.
Waiting for giveback...	Press Ctrl-C, and then respond <code>y</code> when prompted.
System prompt or password prompt	Take over or halt the impaired controller from the healthy controller: <pre>storage failover takeover -ofnode impaired_node_name</pre> <p>When the impaired controller shows Waiting for giveback..., press Ctrl-C, and then respond <code>y</code>.</p>

## Step 2: Remove the controller module

You must remove the controller module from the chassis when you replace the controller module or replace a component inside the controller module.

1. If you are not already grounded, properly ground yourself.
2. Unplug the controller module power supplies from the source.
3. Release the power cable retainers, and then unplug the cables from the power supplies.
4. Loosen the hook and loop strap binding the cables to the cable management device, and then unplug the system cables and SFP and QSFP modules (if needed) from the controller module, keeping track of where the cables were connected. Loosen the hook and loop strap binding the cables to the cable management device, and then unplug the system cables from the controller module, keeping track of where the cables were connected.

Leave the cables in the cable management device so that when you reinstall the cable management device, the cables are organized.

5. Remove the cable management device from the controller module and set it aside.
6. Press down on both of the locking latches, and then rotate both latches downward at the same time.

The controller module moves slightly out of the chassis.

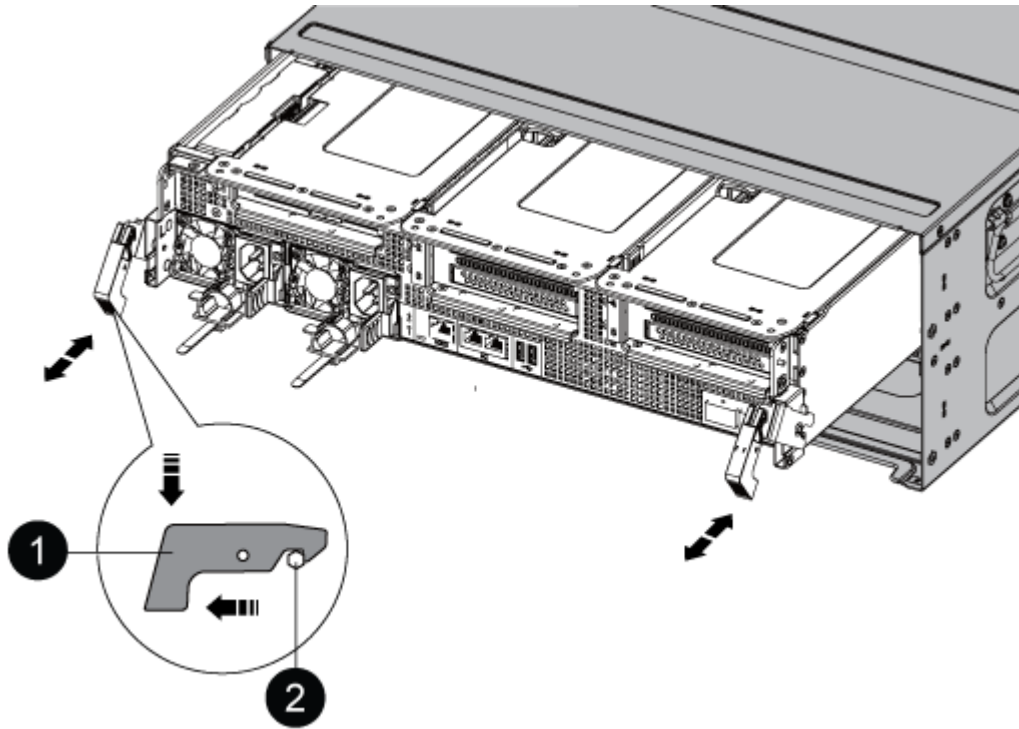

<b>1</b>	Locking latch
<b>2</b>	Locking pin

7. Slide the controller module out of the chassis.

Make sure that you support the bottom of the controller module as you slide it out of the chassis.

8. Set the controller module aside in a safe place.

### Step 3: Replace the NVDIMM battery

To replace the NVDIMM battery, you must remove the failed battery from the controller module and install the replacement battery into the controller module.

1. Open the air duct cover and locate the NVDIMM battery in the riser.

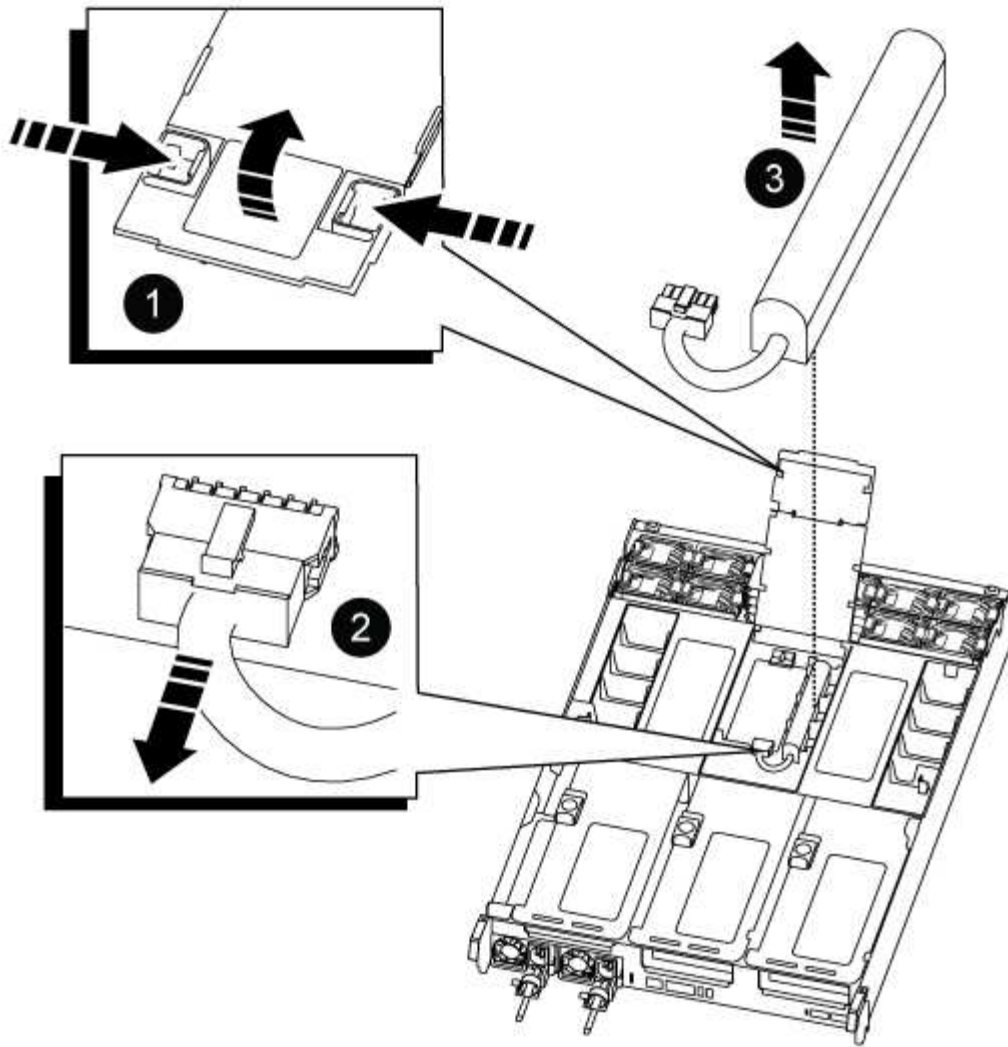

1	Air duct riser
2	NVDIMM battery plug
3	NVDIMM battery pack

**Attention:** The NVDIMM battery control board LED blinks while destaging contents to the flash memory when you halt the system. After the destage is complete, the LED turns off.

1. Locate the battery plug and squeeze the clip on the face of the battery plug to release the plug from the socket, and then unplug the battery cable from the socket.
2. Grasp the battery and lift the battery out of the air duct and controller module, and then set it aside.
3. Remove the replacement battery from its package.
4. Install the replacement battery pack in the NVDIMM air duct:
  - a. Insert the battery pack into the slot and press firmly down on the battery pack to make sure that it is locked into place.

- b. Plug the battery plug into the riser socket and make sure that the plug locks into place.
5. Close the NVDIMM air duct.

Make sure that the plug locks into the socket.

#### Step 4: Reinstall the controller module and booting the system

After you replace a FRU in the controller module, you must reinstall the controller module and reboot it.

1. Align the end of the controller module with the opening in the chassis, and then gently push the controller module halfway into the system.



Do not completely insert the controller module in the chassis until instructed to do so.

2. Recable the system, as needed.

If you removed the media converters (QSFPs or SFPs), remember to reinstall them if you are using fiber optic cables.

3. Plug the power cord into the power supply, reinstall the power cable locking collar, and then connect the power supply to the power source.
4. Complete the reinstallation of the controller module:
  - a. Firmly push the controller module into the chassis until it meets the midplane and is fully seated.

The locking latches rise when the controller module is fully seated.



Do not use excessive force when sliding the controller module into the chassis to avoid damaging the connectors.

The controller module begins to boot as soon as it is fully seated in the chassis.

- b. Rotate the locking latches upward, tilting them so that they clear the locking pins, and then lower them into the locked position.
- c. If you have not already done so, reinstall the cable management device.

#### Step 5: Return the failed part to NetApp

Return the failed part to NetApp, as described in the RMA instructions shipped with the kit. See the [Part Return and Replacements](#) page for further information.

##### Replace PCIe card - ASA A800

To replace a PCIe card, you must disconnect the cables from the cards, remove the SFP and QSFP modules from the cards before removing the riser, reinstall the riser, and then reinstall the SFP and QSFP modules before cabling the cards.

- You can use this procedure with all versions of ONTAP supported by your system
- All other components in the system must be functioning properly; if not, you must contact technical support.

## Step 1: Shut down the impaired controller

To shut down the impaired controller, you must determine the status of the controller and, if necessary, take over the controller so that the healthy controller continues to serve data from the impaired controller storage.

### About this task

- If you have a SAN system, you must have checked event messages (`cluster kernel-service show`) for the impaired controller SCSI blade. The `cluster kernel-service show` command (from `priv advanced mode`) displays the node name, quorum status of that node, availability status of that node, and operational status of that node.

Each SCSI-blade process should be in quorum with the other nodes in the cluster. Any issues must be resolved before you proceed with the replacement.

- If you have a cluster with more than two nodes, it must be in quorum. If the cluster is not in quorum or a healthy controller shows false for eligibility and health, you must correct the issue before shutting down the impaired controller; see [Synchronize a node with the cluster](#).

### Steps

1. If AutoSupport is enabled, suppress automatic case creation by invoking an AutoSupport message:  
`system node autosupport invoke -node * -type all -message MAINT=<# of hours>h`

The following AutoSupport message suppresses automatic case creation for two hours: `cluster1:>`  
`system node autosupport invoke -node * -type all -message MAINT=2h`

2. Disable automatic giveback from the console of the healthy controller: `storage failover modify -node local -auto-giveback false`



When you see *Do you want to disable auto-giveback?*, enter *y*.

3. Take the impaired controller to the LOADER prompt:

If the impaired controller is displaying...	Then...
The LOADER prompt	Go to the next step.
Waiting for giveback...	Press Ctrl-C, and then respond <i>y</i> when prompted.
System prompt or password prompt	Take over or halt the impaired controller from the healthy controller: <code>storage failover takeover -ofnode impaired_node_name</code>  When the impaired controller shows Waiting for giveback..., press Ctrl-C, and then respond <i>y</i> .

## Step 2: Remove the controller module

You must remove the controller module from the chassis when you replace the controller module or replace a component inside the controller module.

1. If you are not already grounded, properly ground yourself.
2. Unplug the controller module power supplies from the source.
3. Release the power cable retainers, and then unplug the cables from the power supplies.
4. Loosen the hook and loop strap binding the cables to the cable management device, and then unplug the system cables and SFP and QSFP modules (if needed) from the controller module, keeping track of where the cables were connected.

Leave the cables in the cable management device so that when you reinstall the cable management device, the cables are organized.

5. Remove the cable management device from the controller module and set it aside.
6. Press down on both of the locking latches, and then rotate both latches downward at the same time.

The controller module moves slightly out of the chassis.

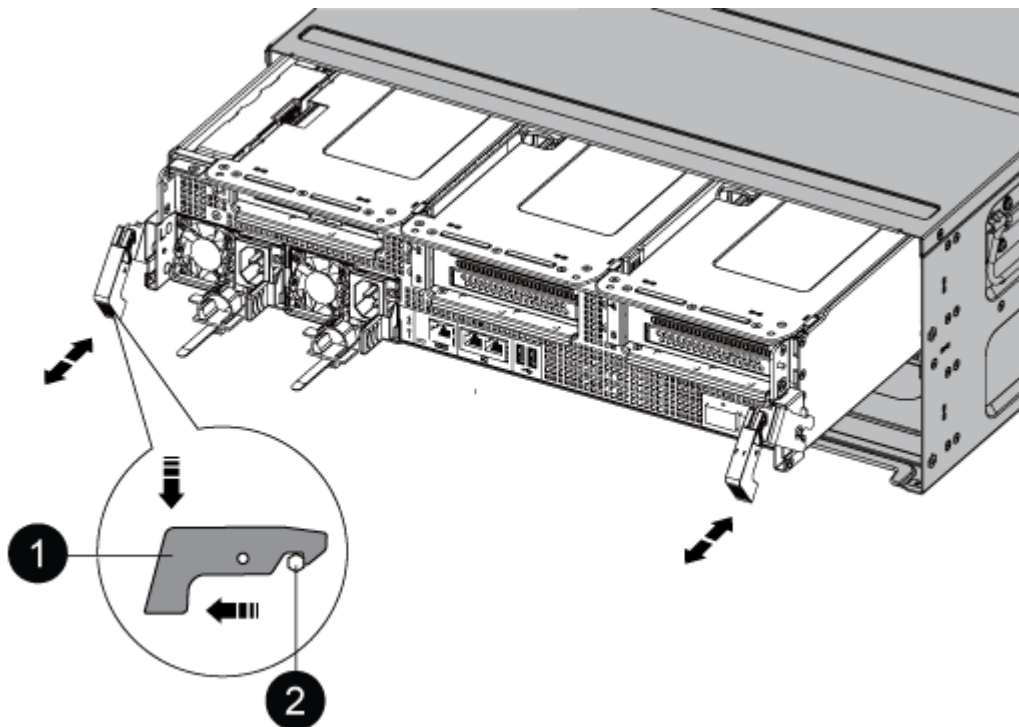

<b>1</b>	Locking latch
<b>2</b>	Locking pin

7. Slide the controller module out of the chassis.

Make sure that you support the bottom of the controller module as you slide it out of the chassis.

8. Place the controller module on a stable, flat surface, and then open the air duct:
  - a. Press in the locking tabs on the sides of the air duct toward the middle of the controller module.
  - b. Slide the air duct toward the fan modules, and then rotate it upward to its completely open position.

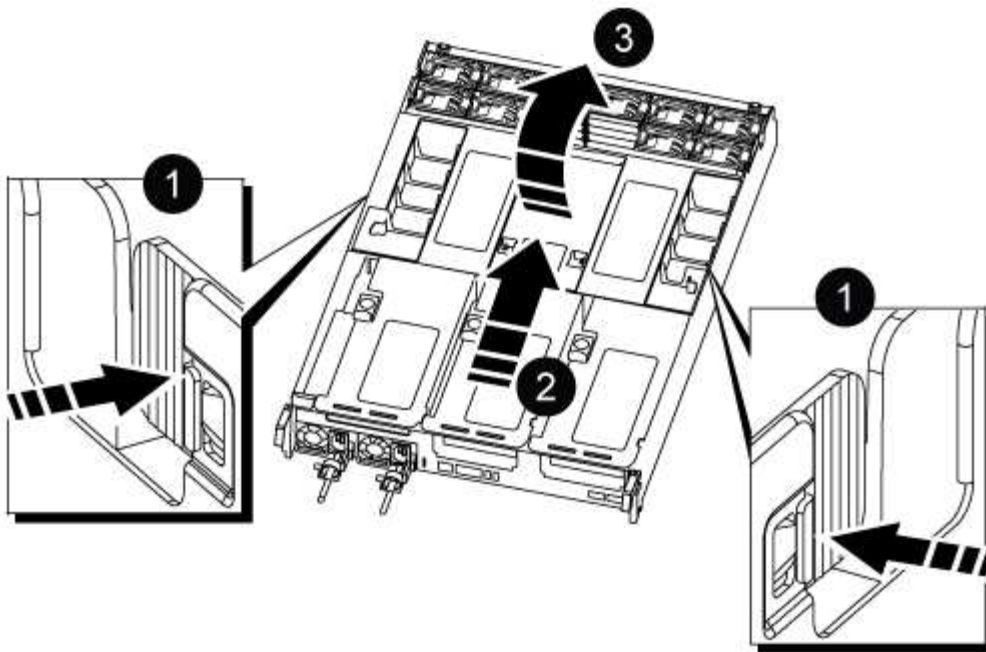

1	Air duct locking tabs
2	Slide air duct towards fan modules
3	Rotate air duct towards fan modules

### Step 3: Replace a PCIe card

To replace a PCIe card, you must remove the cabling and any QSFPs and SFPs from the ports on the PCIe cards in the target riser, remove the riser from the controller module, remove and replace the PCIe card, reinstall the riser and any QSFPs and SFPs onto the ports, and cable the ports.

1. Determine if the card you are replacing is from Riser 1 or if it is from Riser 2 or 3.
  - If you are replacing the 100GbE PCIe card in Riser 1, use Steps 2 - 3 and Steps 6 - 7.
  - If you are replacing a PCIe card from Riser 2 or 3, use Steps 4 through 7.
2. Remove Riser 1 from the controller module:
  - a. Remove the QSFP modules that might be in the PCIe card.
  - b. Rotate the riser locking latch on the left side of the riser up and toward the fan modules.  
  
The riser raises up slightly from the controller module.
  - c. Lift the riser up, shift it toward the fans so that the sheet metal lip on the riser clears the edge of the controller module, lift the riser out of the controller module, and then place it on a stable, flat surface.



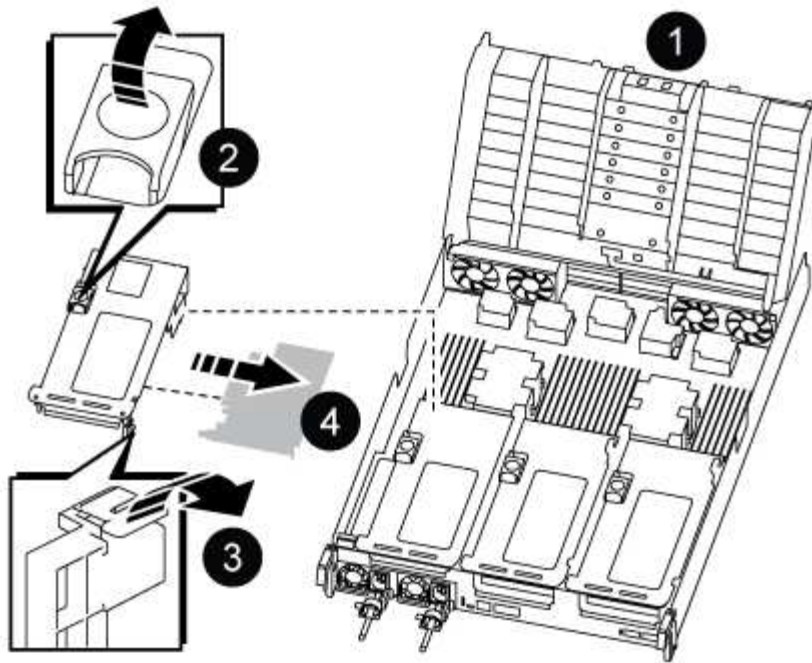

1	Air duct
2	Riser locking latch
3	Card locking bracket
4	Riser 1 (left riser) with 100GbE PCIe card in slot 1.

3. Remove the PCIe card from Riser 1:

- a. Turn the riser so that you can access the PCIe card.
- b. Press the locking bracket on the side of the PCIe riser, and then rotate it to the open position.
- c. Remove the PCIe card from the riser.

4. Remove the PCIe riser from the controller module:

- a. Remove any SFP or QSFP modules that might be in the PCIe cards.
- b. Rotate the riser locking latch on the left side of the riser up and toward the fan modules.

The riser raises up slightly from the controller module.

- c. Lift the riser up, shift it toward the fans so that the sheet metal lip on the riser clears the edge of the controller module, lift the riser out of the controller module, and then place it on a stable, flat surface.

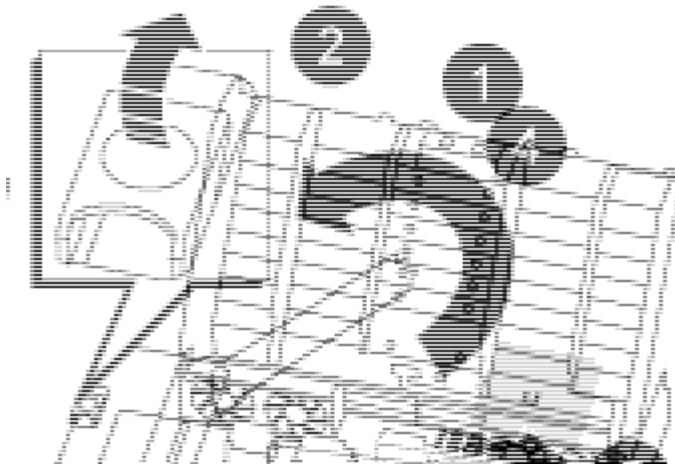

1	Air duct
2	Riser 2 (middle riser) or 3 (right riser) locking latch
3	Card locking bracket
4	Side panel on riser 2 or 3
5	PCIe cards in riser 2 or 3

5. Remove the PCIe card from the riser:
  - a. Turn the riser so that you can access the PCIe cards.
  - b. Press the locking bracket on the side of the PCIe riser, and then rotate it to the open position.
  - c. Swing the side panel off the riser.
  - d. Remove the PCIe card from the riser.
6. Install the PCIe card into the same slot in the riser:
  - a. Align the card with the card socket in the riser, and then slide it squarely into the socket in the riser.
 

 Make sure that the card is completely and squarely seated into the riser socket.
  - b. For Riser 2 or 3, close the side panel.
  - c. Swing the locking latch into place until it clicks into the locked position.
7. Install the riser into the controller module:
  - a. Align the lip of the riser with the underside of the controller module sheet metal.
  - b. Guide the riser along the pins in the controller module, and then lower the riser into the controller module.
  - c. Swing the locking latch down and click it into the locked position.

When locked, the locking latch is flush with the top of the riser and the riser sits squarely in the

controller module.

- d. Reinsert any SFP modules that were removed from the PCIe cards.

#### Step 4: Reinstall the controller module

After you replace a component within the controller module, you must reinstall the controller module in the system chassis and boot it.

1. If you have not already done so, close the air duct:
  - a. Swing the air duct all the way down to the controller module.
  - b. Slide the air duct toward the risers until the locking tabs click into place.
  - c. Inspect the air duct to make sure that it is properly seated and locked into place.

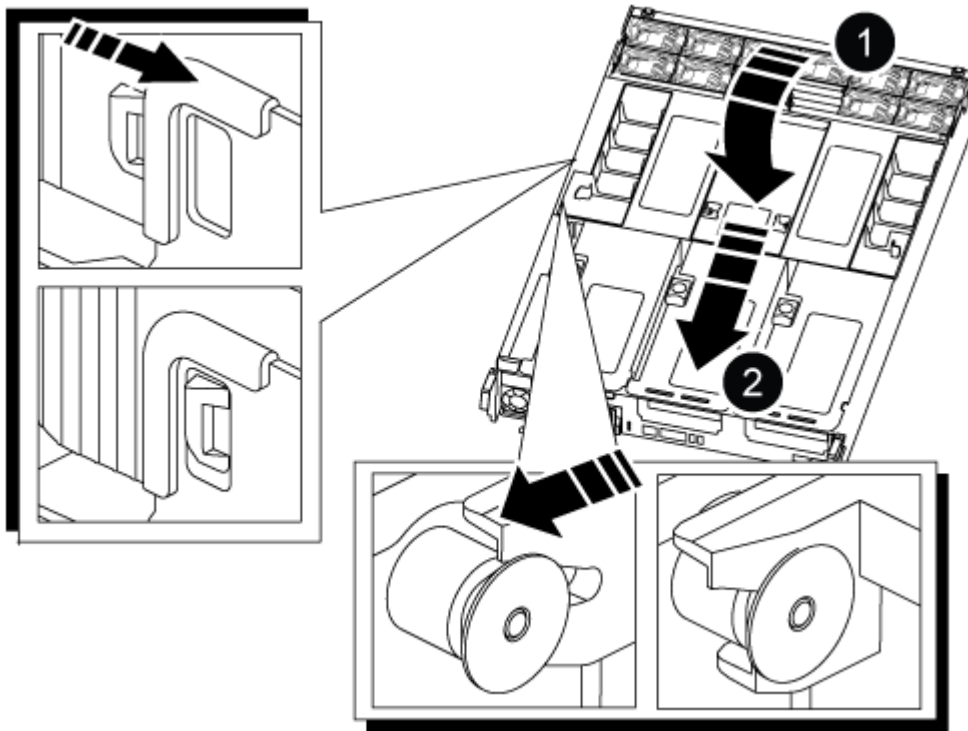

<b>1</b>	Locking tabs
<b>2</b>	Slide plunger

2. Align the end of the controller module with the opening in the chassis, and then gently push the controller module halfway into the system.



Do not completely insert the controller module in the chassis until instructed to do so.

3. Cable the management and console ports only, so that you can access the system to perform the tasks in the following sections.



You will connect the rest of the cables to the controller module later in this procedure.

4. Complete the reinstallation of the controller module:

- a. Firmly push the controller module into the chassis until it meets the midplane and is fully seated.

The locking latches rise when the controller module is fully seated.



Do not use excessive force when sliding the controller module into the chassis to avoid damaging the connectors.

- b. Rotate the locking latches upward, tilting them so that they clear the locking pins, and then lower them into the locked position.

5. Plug the system cables and transceiver modules into the controller module and reinstall the cable management device.

6. Plug the power cables into the power supplies and reinstall the power cable retainers.

The controller module begins to boot as soon as it is connected to power. Be prepared to interrupt the boot process.



If your system has DC power supplies, make sure the thumbscrews on the power supply cable are tight.

7. Return the controller to normal operation by giving back its storage: `storage failover giveback -ofnode impaired_node_name`

8. If automatic giveback was disabled, reenable it: `storage failover modify -node local -auto-giveback true`

### Step 5: Return the failed part to NetApp

Return the failed part to NetApp, as described in the RMA instructions shipped with the kit. See the [Part Return and Replacements](#) page for further information.

#### Replace power supply - ASA A800

Replacing a power supply (PSU) involves disconnecting the target PSU from the power source, unplugging the power cable, removing the old PSU and installing the replacement PSU, and then reconnecting it to the power source.

The power supplies are redundant and hot-swappable.

#### About this task

This procedure is written for replacing one PSU at a time.



It is a best practice to replace the PSU within two minutes of removing it from the chassis. The system continues to function, but ONTAP sends messages to the console about the degraded PSU until the PSU is replaced.



Do not mix PSUs with different efficiency ratings or different input types. Always replace like for like.

Use the appropriate procedure for your type of PSU: AC or DC.

### Option 1: Replace an AC PSU

To replace an AC PSU, complete the following steps.

1. If you are not already grounded, properly ground yourself.
2. Identify the PSU you want to replace, based on console error messages or through the red Fault LED on the PSU.
3. Disconnect the PSU:
  - a. Open the power cable retainer, and then unplug the power cable from the PSU.
  - b. Unplug the power cable from the power source.
4. Remove the PSU by rotating the handle up, press the locking tab, and then pull PSU out of the controller module.



The PSU is short. Always use two hands to support it when removing it from the controller module so that it does not suddenly swing free from the controller module and injure you.

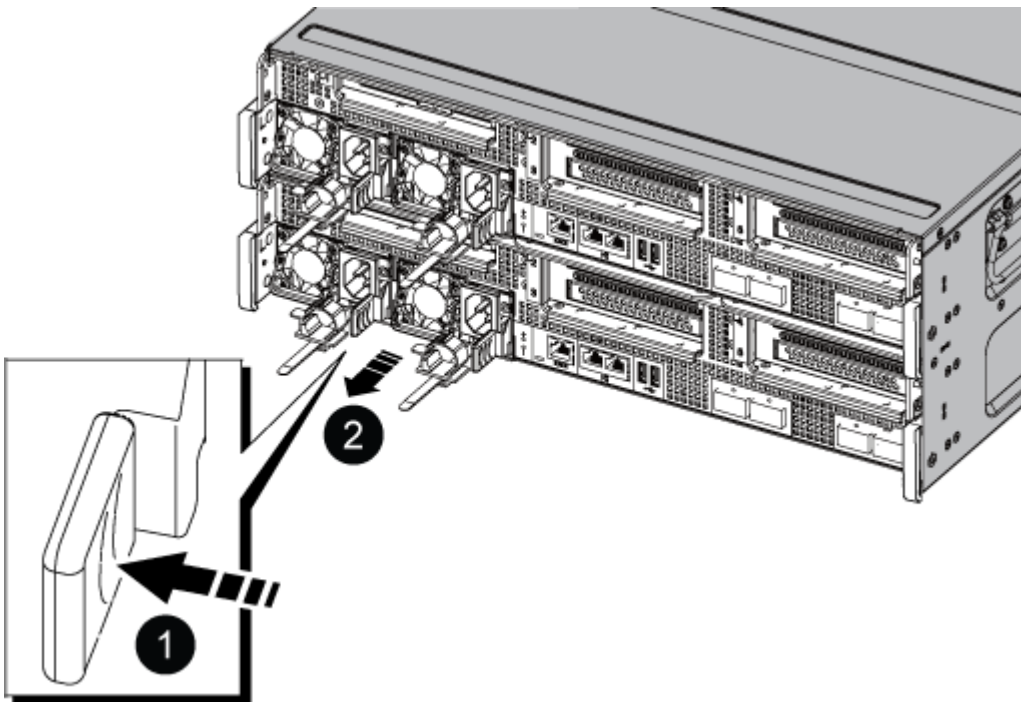

1	Blue PSU locking tab
2	Power supply

5. Install the replacement PSU in the controller module:
  - a. Using both hands, support and align the edges of the replacement PSU with the opening in the controller module.
  - b. Gently push the PSU into the controller module until the locking tab clicks into place.

The power supplies will only properly engage with the internal connector and lock in place one

way.



To avoid damaging the internal connector, do not use excessive force when sliding the PSU into the system.

6. Reconnect the PSU cabling:

- a. Reconnect the power cable to the PSU and the power source.
- b. Secure the power cable to the PSU using the power cable retainer.

Once power is restored to the PSU, the status LED should be green.

7. Return the failed part to NetApp, as described in the RMA instructions shipped with the kit. See the [Part Return and Replacements](#) page for further information.

### Option 2: Replace a DC PSU

To replace a DC PSU, complete the following steps.

1. If you are not already grounded, properly ground yourself.
2. Identify the PSU you want to replace, based on console error messages or through the red Fault LED on the PSU.
3. Disconnect the PSU:
  - a. Unscrew the D-SUB DC cable connector using the thumb screws on the plug.
  - b. Unplug the cable from the PSU and set it aside.
4. Remove the PSU by rotating the handle up, press the locking tab, and then pull the PSU out of the controller module.



The PSU is short. Always use two hands to support it when removing it from the controller module so that it does not suddenly swing free from the controller module and injure you.

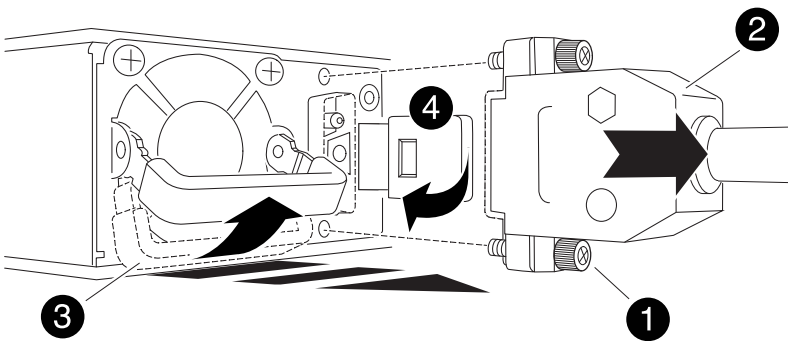

1	Thumb screws
2	D-SUB DC power PSU cable connector
3	Power supply handle

4

Blue PSU locking tab

5. Install the replacement PSU in the controller module:

- a. Using both hands, support and align the edges of the replacement PSU with the opening in the controller module.
- b. Gently push the PSU into the controller module until the locking tab clicks into place.

The power supplies will only properly engage with the internal connector and lock in place one way.



To avoid damaging the internal connector, do not use excessive force when sliding the PSU into the system.

6. Reconnect the D-SUB DC power cable:

- a. Plug the power cable connector into the PSU.
- b. Secure the power cable to the PSU with the thumbscrews.

Once power is restored to the PSU, the status LED should be green.

7. Return the failed part to NetApp, as described in the RMA instructions shipped with the kit. See the [Part Return and Replacements](#) page for further information.

#### Replace the real-time clock battery - ASA A800

You replace the real-time clock (RTC) battery in the controller module so that your system's services and applications that depend on accurate time synchronization continue to function.

- You can use this procedure with all versions of ONTAP supported by your system
- All other components in the system must be functioning properly; if not, you must contact technical support.

#### Step 1: Shut down the impaired controller

To shut down the impaired controller, you must determine the status of the controller and, if necessary, take over the controller so that the healthy controller continues to serve data from the impaired controller storage.

#### About this task

- If you have a SAN system, you must have checked event messages (`cluster kernel-service show`) for the impaired controller SCSI blade. The `cluster kernel-service show` command (from `priv advanced mode`) displays the node name, quorum status of that node, availability status of that node, and operational status of that node.

Each SCSI-blade process should be in quorum with the other nodes in the cluster. Any issues must be resolved before you proceed with the replacement.

- If you have a cluster with more than two nodes, it must be in quorum. If the cluster is not in quorum or a healthy controller shows false for eligibility and health, you must correct the issue before shutting down the impaired controller; see [Synchronize a node with the cluster](#).

## Steps

1. If AutoSupport is enabled, suppress automatic case creation by invoking an AutoSupport message:  
`system node autosupport invoke -node * -type all -message MAINT=<# of hours>h`

The following AutoSupport message suppresses automatic case creation for two hours: `cluster1:>`  
`system node autosupport invoke -node * -type all -message MAINT=2h`

2. Disable automatic giveback from the console of the healthy controller: `storage failover modify -node local -auto-giveback false`



When you see *Do you want to disable auto-giveback?*, enter *y*.

3. Take the impaired controller to the LOADER prompt:

If the impaired controller is displaying...	Then...
The LOADER prompt	Go to the next step.
Waiting for giveback...	Press Ctrl-C, and then respond <i>y</i> when prompted.
System prompt or password prompt	Take over or halt the impaired controller from the healthy controller: <code>storage failover takeover -ofnode impaired_node_name</code>  When the impaired controller shows Waiting for giveback..., press Ctrl-C, and then respond <i>y</i> .

## Step 2: Remove the controller module

You must remove the controller module from the chassis when you replace the controller module or replace a component inside the controller module.

1. If you are not already grounded, properly ground yourself.
2. Unplug the controller module power supplies from the source.
3. Release the power cable retainers, and then unplug the cables from the power supplies.
4. Loosen the hook and loop strap binding the cables to the cable management device, and then unplug the system cables and SFP and QSFP modules (if needed) from the controller module, keeping track of where the cables were connected.

Leave the cables in the cable management device so that when you reinstall the cable management device, the cables are organized.

5. Remove the cable management device from the controller module and set it aside.
6. Press down on both of the locking latches, and then rotate both latches downward at the same time.

The controller module moves slightly out of the chassis.



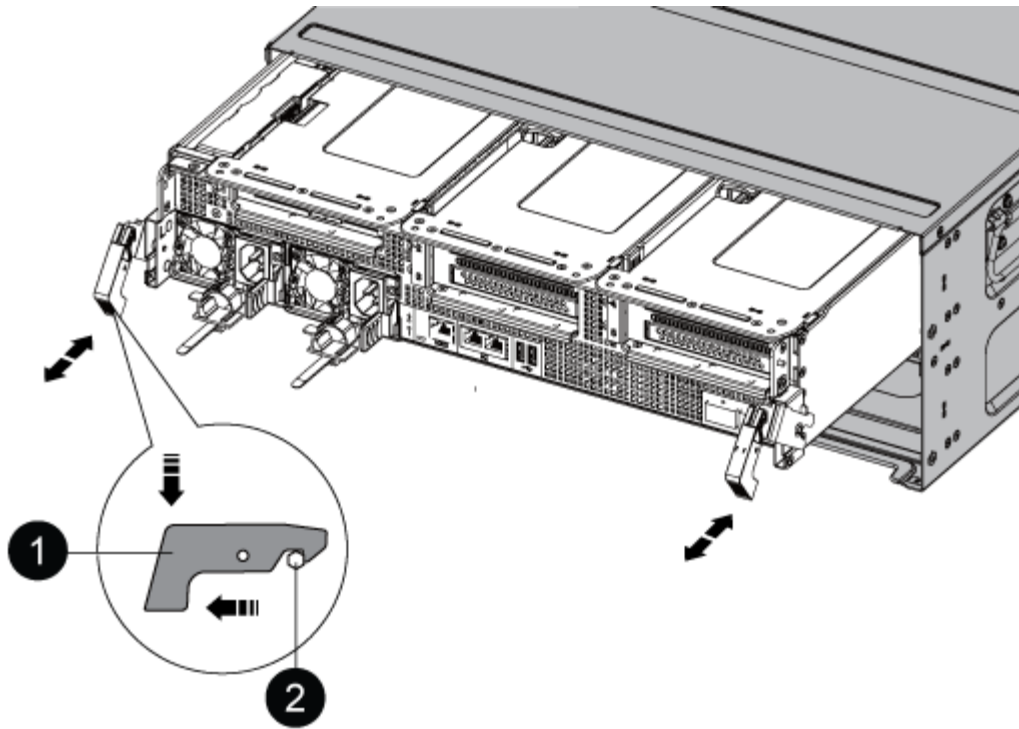

1	Locking latch
2	Locking pin

1. Slide the controller module out of the chassis.

Make sure that you support the bottom of the controller module as you slide it out of the chassis.

2. Place the controller module on a stable, flat surface, and then open the air duct:

- a. Press in the locking tabs on the sides of the air duct toward the middle of the controller module.
- b. Slide the air duct toward the fan modules, and then rotate it upward to its completely open position.

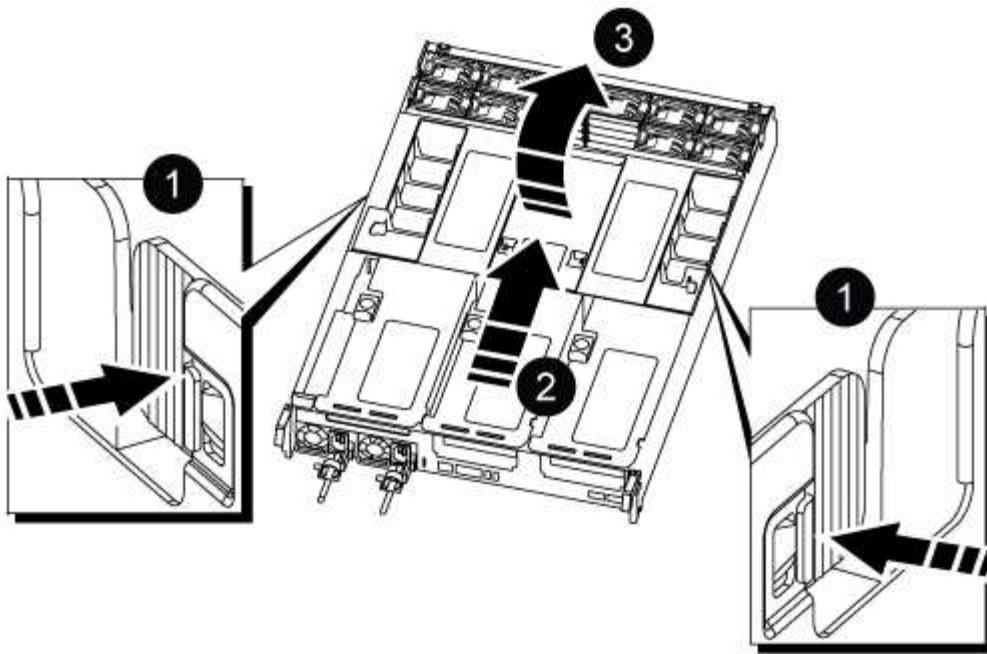

1	Air duct locking tabs
2	Slide air duct towards fan modules
3	Rotate air duct towards fan modules

**Step 3: Replace the RTC battery**

## Original controller

1. Remove PCIe riser 2 (middle riser) from the controller module:
  - a. Remove any SFP or QSFP modules that might be in the PCIe cards.
  - b. Rotate the riser locking latch on the left side of the riser up and toward the fan modules.

The riser raises up slightly from the controller module.

- c. Lift the riser up, shift it toward the fans so that the sheet metal lip on the riser clears the edge of the controller module, lift the riser out of the controller module, and then place it on a stable, flat surface.

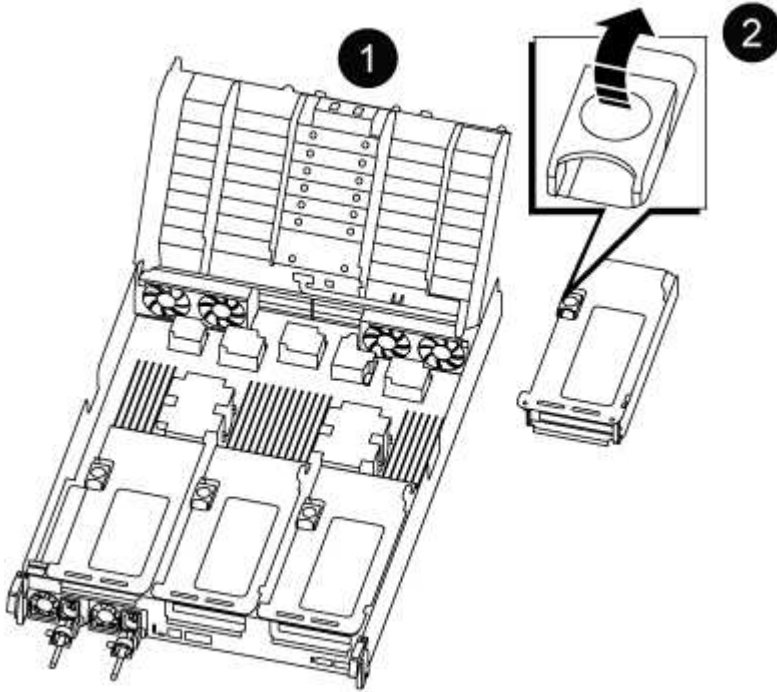

<b>1</b>	Air duct
<b>2</b>	Riser 2 (middle riser) locking latch

2. Locate the RTC battery under Riser 2.

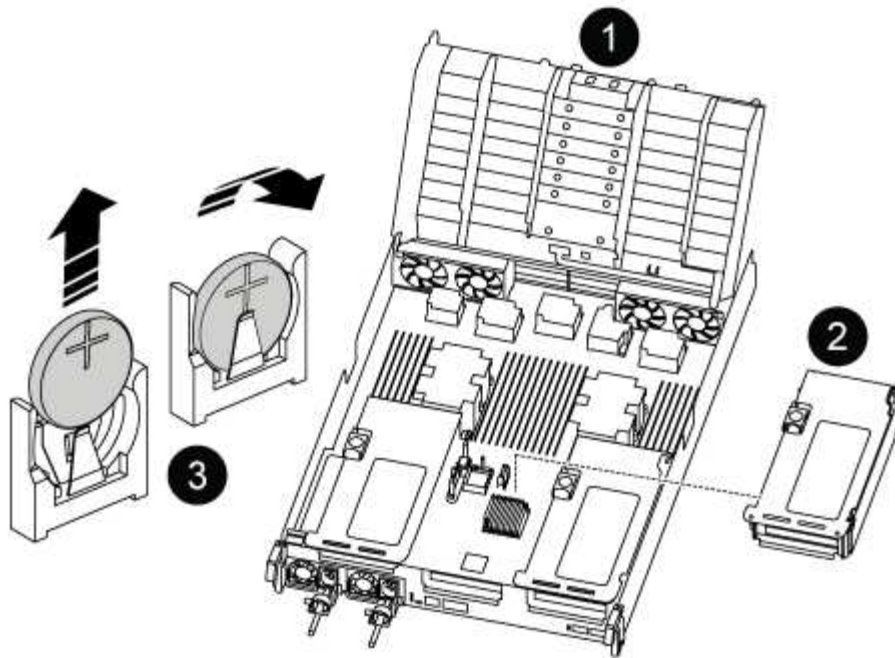

1	Air duct
2	Riser 2
3	RTC battery and housing

3. Gently push the battery away from the holder, rotate it away from the holder, and then lift it out of the holder.



Note the polarity of the battery as you remove it from the holder. The battery is marked with a plus sign and must be positioned in the holder correctly. A plus sign near the holder tells you how the battery should be positioned.

4. Remove the replacement battery from the antistatic shipping bag.
5. Note the polarity of the RTC battery, and then insert it into the holder by tilting the battery at an angle and pushing down.
6. Visually inspect the battery to make sure that it is completely installed into the holder and that the polarity is correct.
7. Install the riser into the controller module:
  - a. Align the lip of the riser with the underside of the controller module sheet metal.
  - b. Guide the riser along the pins in the controller module, and then lower the riser into the controller module.
  - c. Swing the locking latch down and click it into the locked position.

When locked, the locking latch is flush with the top of the riser and the riser sits squarely in the controller module.

d. Reinsert any SFP modules that were removed from the PCIe cards.

### VER2 controller

1. Locate the RTC battery near the DIMMs.

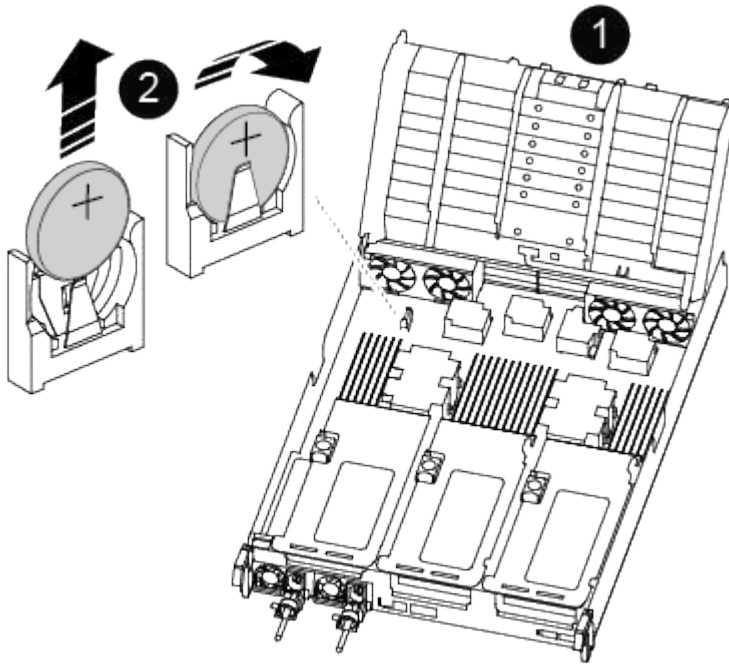

1	Air duct
2	RTC battery and housing

2. Gently push the battery away from the holder, rotate it away from the holder, and then lift it out of the holder.



Note the polarity of the battery as you remove it from the holder. The battery is marked with a plus sign and must be positioned in the holder correctly. A plus sign near the holder tells you how the battery should be positioned.

3. Remove the replacement battery from the antistatic shipping bag.
4. Note the polarity of the RTC battery, and then insert it into the holder by tilting the battery at an angle and pushing down.
5. Visually inspect the battery to make sure that it is completely installed into the holder and that the polarity is correct.

### Step 4: Reinstall the controller module

After you replace a component within the controller module, you must reinstall the controller module in the system chassis, reset the time and date on the controller, and then boot it.

1. If you have not already done so, close the air duct or controller module cover.

2. Align the end of the controller module with the opening in the chassis, and then gently push the controller module halfway into the system.

Do not completely insert the controller module in the chassis until instructed to do so.

3. Recable the system, as needed.

If you removed the media converters (QSFPs or SFPs), remember to reinstall them if you are using fiber optic cables.

4. If the power supplies were unplugged, plug them back in and reinstall the power cable retainers.
5. Complete the reinstallation of the controller module:

- a. Firmly push the controller module into the chassis until it meets the midplane and is fully seated.

The locking latches rise when the controller module is fully seated.



Do not use excessive force when sliding the controller module into the chassis to avoid damaging the connectors.

The controller module begins to boot as soon as it is fully seated in the chassis.

- b. Rotate the locking latches upward, tilting them so that they clear the locking pins, and then lower them into the locked position.
- c. If you have not already done so, reinstall the cable management device.
- d. Halt the controller at the LOADER prompt.
6. Reset the time and date on the controller:
  - a. Check the date and time on the healthy controller with the `show date` command.
  - b. At the LOADER prompt on the target controller, check the time and date.
  - c. If necessary, modify the date with the `set date mm/dd/yyyy` command.
  - d. If necessary, set the time, in GMT, using the `set time hh:mm:ss` command.
  - e. Confirm the date and time on the target controller.
7. At the LOADER prompt, enter `bye` to reinitialize the PCIe cards and other components and let the controller reboot.
8. Return the controller to normal operation by giving back its storage: `storage failover giveback -ofnode impaired_node_name`
9. If automatic giveback was disabled, reenable it: `storage failover modify -node local -auto-giveback true`

### Step 5: Return the failed part to NetApp

Return the failed part to NetApp, as described in the RMA instructions shipped with the kit. See the [Part Return and Replacements](#) page for further information.

## ASA A900 systems

## Install and setup

**Start here:** Choose your installation and setup experience

You can choose from different content formats to guide you through installing and setting up your new storage system.

- [Quick steps](#)

A printable PDF of step-by-step instructions with live links to additional content.

- [Video steps](#)

Video step-by-step instructions.

- [Detailed steps](#)

Online step-by-step instructions with live links to additional content.

### Quick steps - ASA A900

The quick guide provides graphic instructions for a typical installation of your system, from racking and cabling, through initial system bring-up. Use this content if you are familiar with installing NetApp systems.

Use the [xref:./asa900/AFF A900 Installation and Setup Instructions](#)



The ASA A900 uses the same installation procedure as the AFF A900 system.

### Video steps - ASA A900

The following video shows how to install and cable your new system.

[Animation - AFF A900 Installation and setup instructions](#)



The ASA A900 uses the same installation procedure as the AFF A900 system.

### Detailed steps - ASA 900

This page provides detailed step-by-step instructions for installing a typical NetApp system. Use this article if you want more detailed installation instructions.

#### Step 1: Prepare for installation

To install your system, you need to create an account on the NetApp Support Site, register your system, and get license keys. You also need to inventory the appropriate number and type of cables for your system and collect specific network information.

You need to have access to the [NetApp Hardware Universe](#) for information about site requirements as well as additional information on your configured system.

#### What you need

You might also want to have access to the [ONTAP 9 Release Notes](#) for your version of ONTAP for more information about this system.

You need to provide the following at your site:

- Rack space for the storage system
- Phillips #2 screwdriver
- Additional networking cables to connect your system to your network switch and laptop or console with a Web browser

### Steps



1. Unpack the contents of all boxes.
2. Record the system serial number from the controllers.







3. Inventory and make a note of the number and types of cables you received.

The following table identifies the types of cables you might receive. If you receive a cable not listed in the table, see the Hardware Universe to locate the cable and identify its use.

#### [NetApp Hardware Universe](#)

Type of cable...	Part number and length	Connector type	For...
25 GbE data Cable	X66240A-05 (112-00639), 0.5m X66240A-2 (112-00598), 2m X66240A-5 (112-00600), 5m		Network cable
32 Gb FC (SFP+ Op)	X66250-2 (112-00342), 2m X66250-5 (112-00344), 5m X66250-15 (112-00346), 15m		FC optical network cable
40 GbE network cable	X66100-1 (112-00542), 1m X66100-3 (112-00543), 3m X66100-5 (112-00544), 5m		Ethernet data, cluster network



Type of cable...	Part number and length	Connector type	For...
100 GbE cable	X66211B-1 (112-00573), 1m X66211B-2 (112-00574), 2m X66211B-5 (112-00576), 5m		Network, NVME storage, Ethernet data, cluster network
Optical cables	X66031A (112-00436), 1m X66032A (112-00437), 2m X66033A (112-00438), 3m		FC optical network
Cat 6, RJ-45 (order dependent)	Part numbers X6585-R6 (112-00291), 3m X6562-R6 (112-00196), 5m		Management network and Ethernet data
Micro-USB console cable	Not applicable		Console connection during software setup on non-Windows or Mac laptop/console
Power cables	Not applicable		Powering up the system

4. Review the [ONTAP Configuration Guide](#) and collect the required information listed in that guide.

## Step 2: Install the hardware

You need to install your system in a 4-post rack or NetApp system cabinet, as applicable.

1. Install the rail kits, as needed.
2. Install and secure your system using the instructions included with the rail kit.



You need to be aware of the safety concerns associated with the weight of the system.

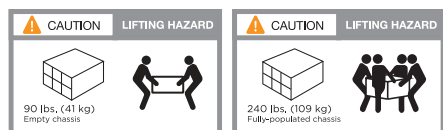

3. Attach cable management devices (as shown).

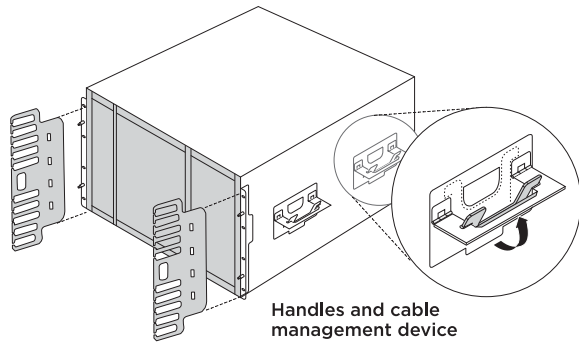

4. Place the bezel on the front of the system.

The following diagram shows a representation of what a typical system looks like and where the major components are located at the rear of the system:

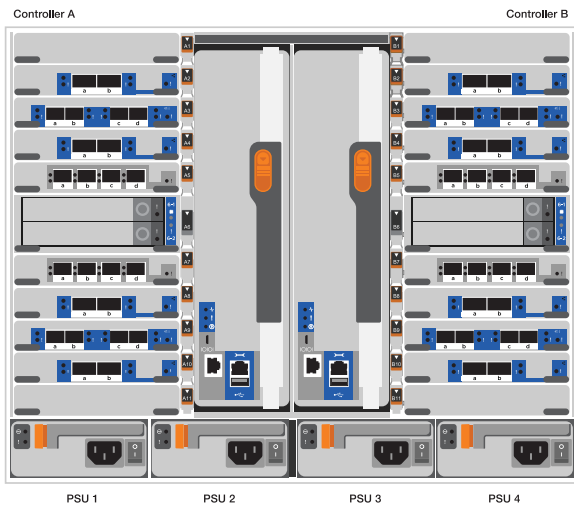

### Step 3: Cable controllers to your network

You can cable the controllers to your network by using the two-node switchless cluster method or by using the cluster interconnect network.

## Option 1: Two-node switchless cluster

Management network, data network, and management ports on the controllers are connected to switches. The cluster interconnect ports are cabled on both controllers.

### Before you begin

You must have contacted your network administrator for information about connecting the system to the switches.

Be sure to check the direction of the cable pull-tabs when inserting the cables in the ports. Cable pull-tabs are up for all networking module ports.

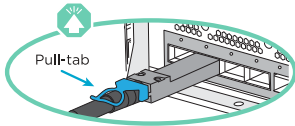



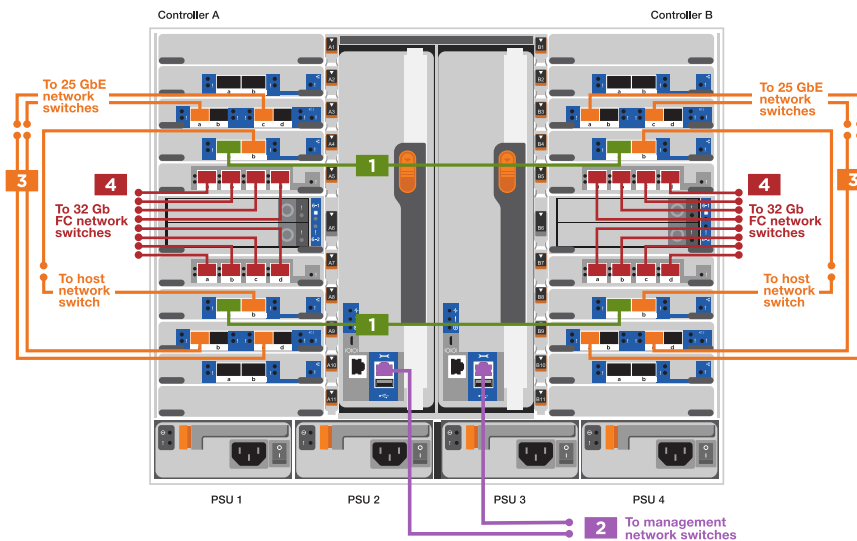

As you insert the connector, you should feel it click into place; if you do not feel it click, remove it, turn it around and try again.

1. Use the animation or illustration to complete the cabling between the controllers and to the switches:

### Animation - Cable a two-node switchless cluster

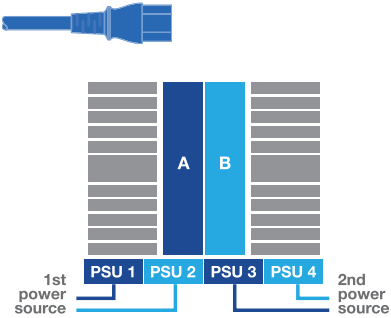

Step	Perform on each controller
1	<p>Cable cluster interconnect ports:</p> <ul style="list-style-type: none"><li>• Slot A4 and B4 (e4a)</li><li>• Slot A8 and B8 (e8a)</li></ul> 

Step	Perform on each controller
2	Cable controller management (wrench) ports. 
3	Cable 25 GbE network switches: Ports in slot A3 and B3 (e3a and e3c) and slot A9 and B9 (e9a and e9c) to the 25 GbE network switches.  40GbE host network switches: Cable host-side b ports in slot A4 and B4 (e4b) and slot A8 and B8 (e8b) to the host switch. 
4	Cable 32 Gb FC connections: Cable ports in slot A5 and B5 (5a, 5b, 5c, and 5d) and slot A7 and B7 (7a, 7b, 7c, and 7d) to the 32 Gb FC network switches. 
<ul style="list-style-type: none"> <li>• Strap the cables to the cable management arms (not shown).</li> <li>• Connect the power cables to the PSUs and connect them to different power sources (not shown). PSU 1 and 3 provide power to all side A components, while PSU2 and PSU4 provide power to all side B components.</li> </ul>	

### Option 2: Switched cluster

Management network, data network, and management ports on the controllers are connected to switches. The cluster interconnect and HA ports are cabled on to the cluster/HA switch.

#### Before you begin

You must have contacted your network administrator for information about connecting the system to the switches.

Be sure to check the direction of the cable pull-tabs when inserting the cables in the ports. Cable pull-tabs are up for all networking module ports.

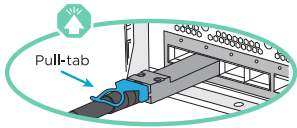





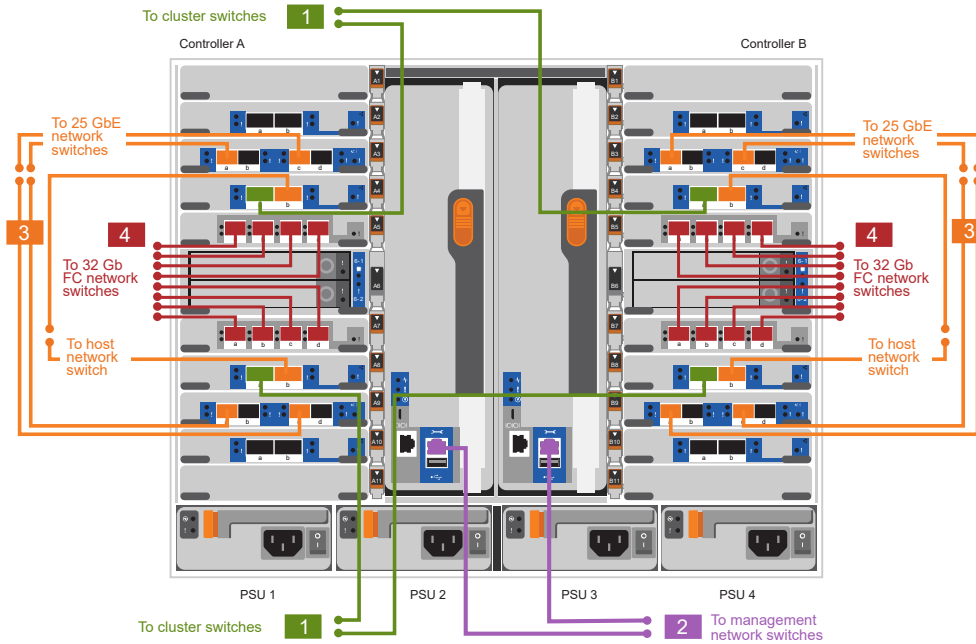

As you insert the connector, you should feel it click into place; if you do not feel it click, remove it, turn it over and try again.

1. Use the animation or illustration to complete the cabling between the controllers and to the switches:

### Animation - Cable a switched cluster

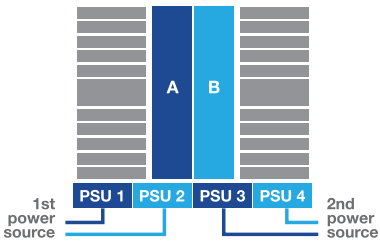

Step	Perform on each controller
<div style="background-color: #008000; color: white; padding: 2px; display: inline-block; width: 20px; height: 20px; text-align: center; line-height: 20px;">1</div>	<p>Cable cluster interconnect a ports:</p> <ul style="list-style-type: none"> <li>• Slot A4 and B4 (e4a) to the cluster network switch.</li> <li>• Slot A8 and B8 (e8a) to the cluster network switch.</li> </ul> 
<div style="background-color: #660099; color: white; padding: 2px; display: inline-block; width: 20px; height: 20px; text-align: center; line-height: 20px;">2</div>	<p>Cable controller management (wrench) ports.</p> 

Step	Perform on each controller
<p data-bbox="215 155 274 195"><b>3</b></p>	<p data-bbox="841 155 1239 191">Cable 25GbE network switches:</p> <p data-bbox="841 226 1336 327">Ports in slot A3 and B3 (e3a and e3c) and slot A9 and B9 (e9a and e9c) to the 25 GbE network switches.</p>  <p data-bbox="841 428 1219 464">40GbE host network switches:</p> <p data-bbox="841 499 1304 600">Cable host-side b ports in slot A4 and B4 (e4b) and slot A8 and B8 (e8b) to the host switch.</p> 
<p data-bbox="215 716 274 756"><b>4</b></p>	<p data-bbox="841 716 1208 751">Cable 32 Gb FC connections:</p> <p data-bbox="841 787 1271 921">Cable ports in slot A5 and B5 (5a, 5b, 5c, and 5d) and slot A7 and B7 (7a, 7b, 7c, and 7d) to the 32 Gb FC network switches.</p> 
<ul data-bbox="240 1041 816 1329" style="list-style-type: none"> <li>• Strap the cables to the cable management arms (not shown).</li> <li>• Connect the power cables to the PSUs and connect them to different power sources (not shown). PSU 1 and 3 provide power to all side A components, while PSU2 and PSU4 provide power to all side B components.</li> </ul>	 

#### Step 4: Cable controllers to drive shelves

Cable either a single NS224 drive shelf or two NS224 drive shelves to your controllers.

### Option 1: Cable the controllers to a single NS224 drive shelf

You must cable each controller to the NSM modules on the NS224 drive shelf.

#### Before you begin

- Be sure to check the illustration arrow for the proper cable connector pull-tab orientation. The cable pull-tab for the storage modules are up, while the pull tabs on the shelves are down.

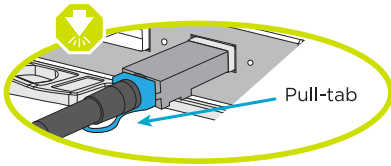
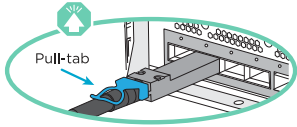



As you insert the connector, you should feel it click into place; if you do not feel it click, remove it, turn it around and try again.

1. Use the following animation or drawings to cable your controllers to a single NS224 drive shelf.

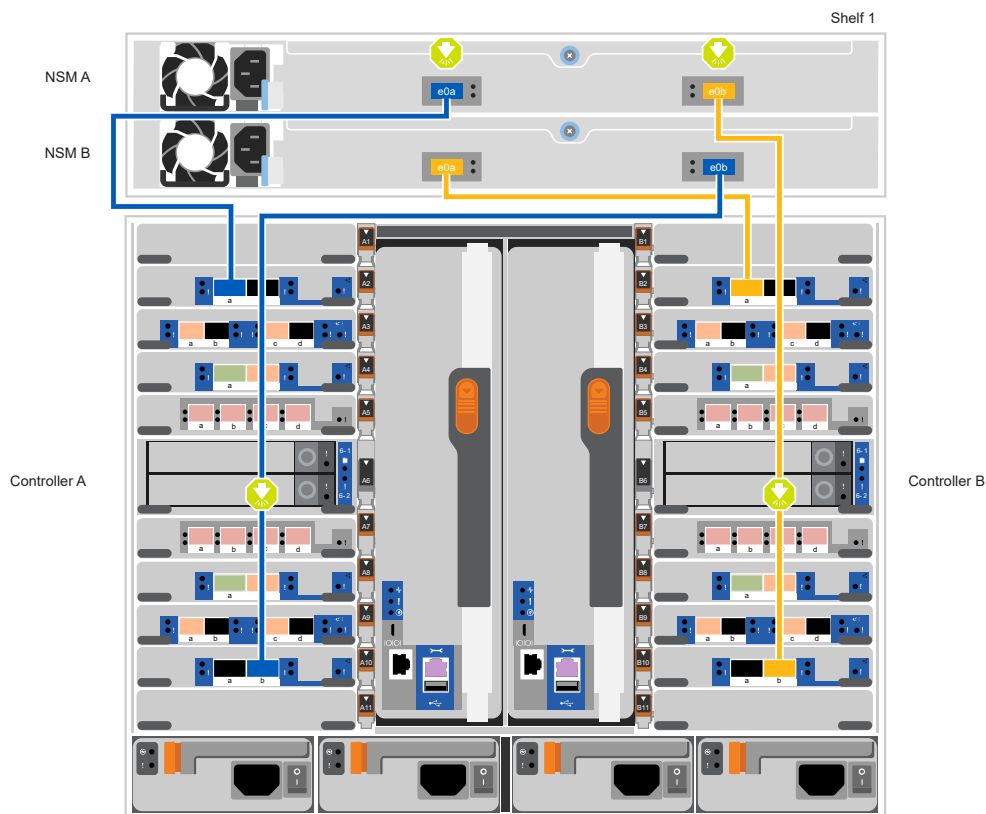
#### Animation - Cable a single NS224 shelf



Step	Perform on each controller
<p><b>1</b></p>	<ul style="list-style-type: none"> <li>• Connect controller A port e2a to port e0a on NSM A on the shelf.</li> <li>• Connect controller A port e10b to port e0b on NSM B on the shelf.</li> </ul>  <p>100 GbE cable</p>
<p><b>2</b></p>	<ul style="list-style-type: none"> <li>• Connect controller B port e2a to port e0a on NSM B on the shelf.</li> <li>• Connect controller B port e10b to port e0b on NSM A on the shelf.</li> </ul>  <p>100 GbE cable</p>

### Option 2: Cable the controllers to two NS224 drive shelves

You must cable each controller to the NSM modules on the NS224 drive shelves.

#### Before you begin

- Be sure to check the illustration arrow for the proper cable connector pull-tab orientation. The cable pull-tab for the storage modules are up, while the pull tabs on the shelves are down.

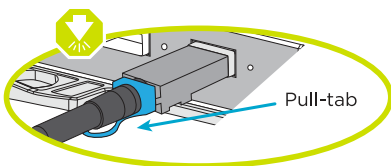
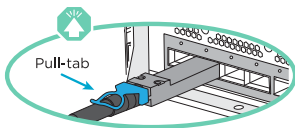

As you insert the connector, you should feel it click into place; if you do not feel it click, remove it, turn it around and try again.

1. Use the following animation or diagram to cable your controllers to two NS224 drive shelves.

[Animation - Cable two NS224 shelves](#)



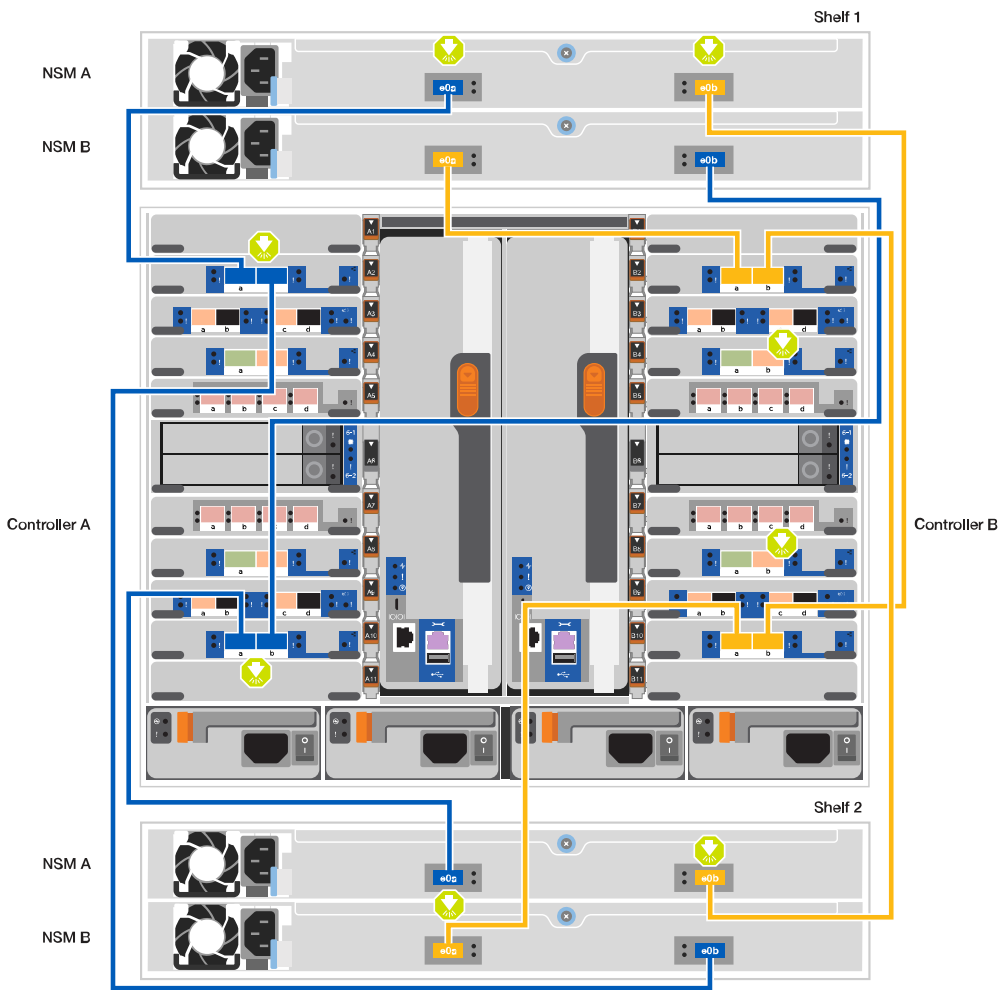
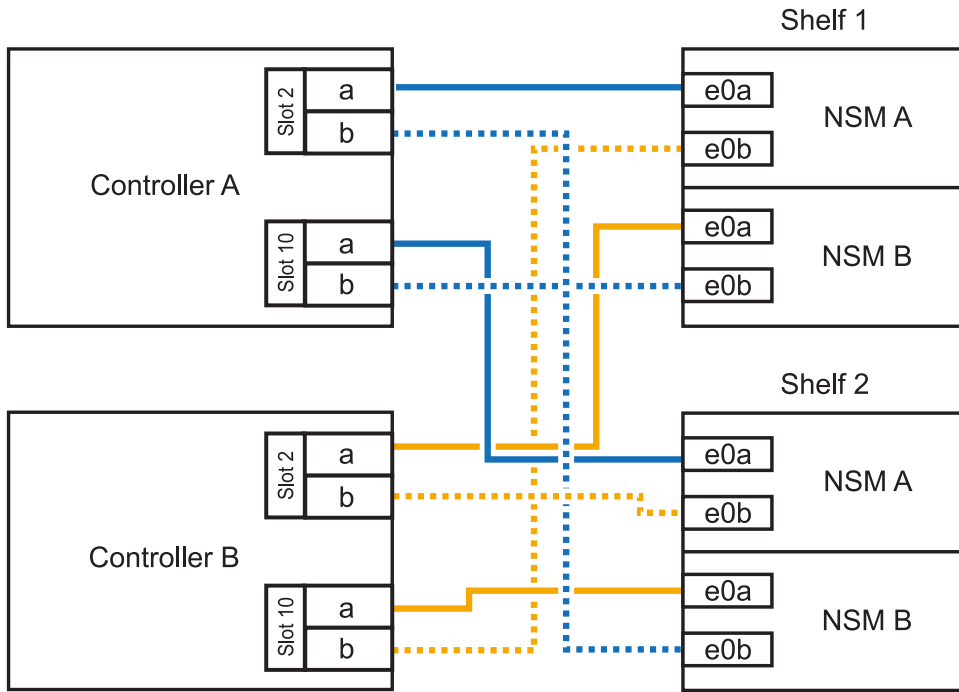

Step	Perform on each controller
<p><b>1</b></p>	<ul style="list-style-type: none"> <li>• Connect controller A port e2a to NSM A e0a on shelf 1.</li> <li>• Connect controller A port e10b to NSM B e0b on shelf 1.</li> <li>• Connect controller A port e2b to NSM B e0b on shelf 2.</li> <li>• Connect controller A port e10a to NSM A e0a on shelf 2.</li> </ul>  <p>100 GbE cable</p>
<p><b>2</b></p>	<ul style="list-style-type: none"> <li>• Connect controller B port e2a to NSM B e0a on shelf 1.</li> <li>• Connect controller B port e10b to NSM A e0b on shelf 1.</li> <li>• Connect controller B port e2b to NSM A e0b on shelf 2.</li> <li>• Connect controller B port e10a to NSM B e0a on shelf 2.</li> </ul>  <p>100 GbE cable</p>

### Step 5: Complete system setup and configuration

You can complete the system setup and configuration using cluster discovery with only a connection to the switch and laptop, or by connecting directly to a controller in the system and then connecting to the management switch.

### Option 1: If network discovery is enabled

If you have network discovery enabled on your laptop, you can complete system setup and configuration using automatic cluster discovery.

1. Use the following animation or drawing to set one or more drive shelf IDs:

The NS224 shelves are pre-set to shelf ID 00 and 01. If you want to change the shelf IDs, you must create a tool to insert into the hole where button is located. see [Change a shelf ID - NS224 shelves](#) for detailed instructions.

#### Animation - Set NVMe drive shelf IDs

[drw a900 oie change ns224 shelf ID IEOPS 836]

1	Shelf end cap
2	Shelf faceplate
3	Shelf ID LED
4	Shelf ID setting button

2. Turn on the power switches on the power supplies to both nodes.

#### Animation - Turn on the power to the controllers

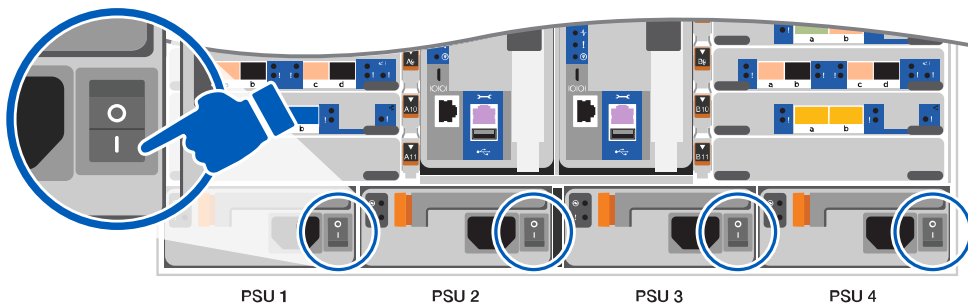

Initial booting may take up to eight minutes.

3. Make sure that your laptop has network discovery enabled.

See your laptop's online help for more information.

4. Use the following animation to connect your laptop to the Management switch.

#### Animation - Connect your laptop to the Management switch



5. Select an ONTAP icon listed to discover:

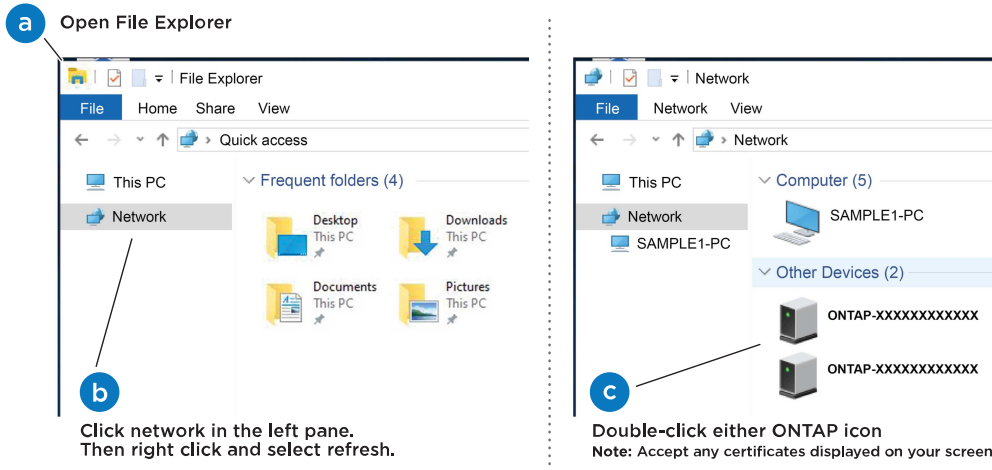

- a. Open File Explorer.
- b. Click network in the left pane.
- c. Right click and select refresh.
- d. Double-click either ONTAP icon and accept any certificates displayed on your screen.



XXXXX is the system serial number for the target node.

System Manager opens.

6. Use System Manager guided setup to configure your system using the data you collected in the [ONTAP Configuration Guide](#).
7. Set up your account and download Active IQ Config Advisor:
  - a. Log in to your existing account or create an account.
 

[NetApp Support Registration](#)
  - b. Register your system.
 

[NetApp Product Registration](#)
  - c. Download Active IQ Config Advisor.
 

[NetApp Downloads: Config Advisor](#)
8. Verify the health of your system by running Config Advisor.

9. After you have completed the initial configuration, go to the [ONTAP & ONTAP System Manager Documentation Resources](#) page for information about configuring additional features in ONTAP.

### Option 2: If network discovery is not enabled

If you are not using a Windows or Mac-based laptop or console or if auto discovery is not enabled, you must complete the configuration and setup using this task.

1. Cable and configure your laptop or console:

a. Set the console port on the laptop or console to 115,200 baud with N-8-1.



See your laptop or console's online help for how to configure the console port.

b. Connect the console cable to the laptop or console using the console cable that came with your system, and then connect the laptop to the management switch on the management subnet.

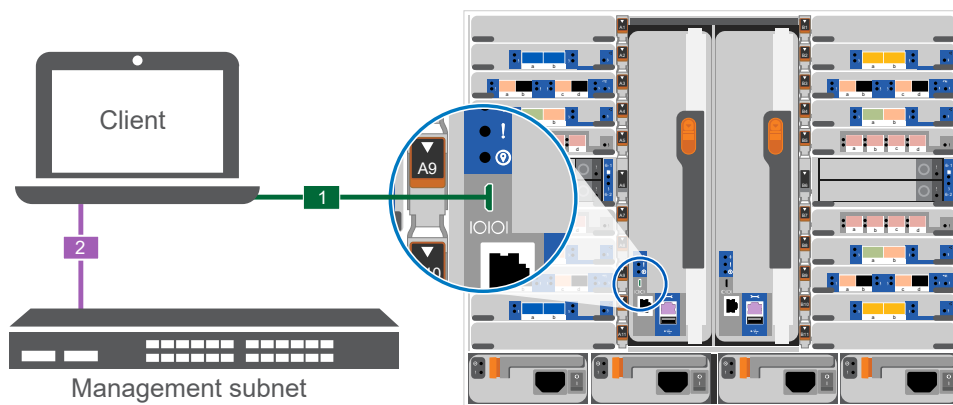

c. Assign a TCP/IP address to the laptop or console, using one that is on the management subnet.

2. Use the following animation to set one or more drive shelf IDs:

The NS224 shelves are pre-set to shelf ID 00 and 01. If you want to change the shelf IDs, you must create a tool to insert into the hole where button is located. see [Change a shelf ID - NS224 shelves](#) for detailed instructions.

#### Animation - Set NVMe drive shelf IDs

[drw a900 oie change ns224 shelf ID IEOPS 836]

1	Shelf end cap
2	Shelf faceplate
3	Shelf ID LED
4	Shelf ID setting button

3. Turn on the power switches on the power supplies to both nodes.

#### Animation - Turn on the power to the controllers

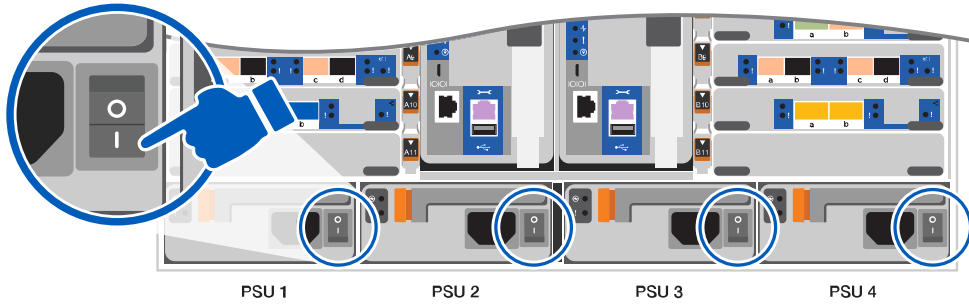

 Initial booting may take up to eight minutes.

4. Assign an initial node management IP address to one of the nodes.

If the management network has DHCP...	Then...
Configured	Record the IP address assigned to the new controllers.
Not configured	<p>a. Open a console session using PuTTY, a terminal server, or the equivalent for your environment.</p> <p> Check your laptop or console's online help if you do not know how to configure PuTTY.</p> <p>b. Enter the management IP address when prompted by the script.</p>

5. Using System Manager on your laptop or console, configure your cluster:

a. Point your browser to the node management IP address.

 The format for the address is `https://x.x.x.x`.

b. Configure the system using the data you collected in the [ONTAP Configuration Guide](#)

6. Set up your account and download Active IQ Config Advisor:

a. Log in to your existing account or create an account.

[NetApp Support Registration](#)

b. Register your system.

[NetApp Product Registration](#)

c. Download Active IQ Config Advisor.

[NetApp Downloads: Config Advisor](#)

7. Verify the health of your system by running Config Advisor.

8. After you have completed the initial configuration, go to the [ONTAP & ONTAP System Manager Documentation Resources](#) page for information about configuring additional features in ONTAP.

## Maintain

### Maintain ASA A900 hardware

For the ASA A900 storage system, you can perform maintenance procedures on the following components.

### Boot media

The boot media stores a primary and secondary set of boot image files that the system uses when it boots.

### Chassis

The chassis is the physical enclosure housing all the controller components such as the controller/CPU unit, power supply, and I/O.

### Controller

A controller consists of a board, firmware, and software. It controls the drives and implements the ONTAP functions.

### DIMM

You must replace a DIMM (dual in-line memory module) when a memory mismatch is present, or you have a failed DIMM.

### DCPM

The DCPM (destage controller power module) contains the NVRAM11 battery.

### Fan

The fan cools the controller.

### I/O module

The I/O module (Input/Output module) is a hardware component that acts as an intermediary between the controller and various devices or systems that need to exchange data with the controller.

### LED USB

The LED USB module provides connectivity to console ports and system status.

### NVRAM

The NVRAM module (Non-Volatile Random Access Memory) allows the controller to retain data across power cycles or system reboots.

## Power supply

A power supply provides a redundant power source in a controller shelf.

## Real-time clock battery

A real time clock battery preserves system date and time information if the power is off.

## Boot media

### Replace the boot media - ASA A900

The boot media stores a primary and secondary set of system (boot image) files that the system uses when it boots. Depending on your network configuration, you can perform either a nondisruptive or disruptive replacement.

You must have a USB flash drive, formatted to FAT32, with the appropriate amount of storage to hold the `image_XXX.tgz`.

You also must copy the `image_XXX.tgz` file to the USB flash drive for later use in this procedure.

- The nondisruptive and disruptive methods for replacing a boot media both require you to restore the `var` file system:
  - For nondisruptive replacement, the HA pair does not require connection to a network to restore the `var` file system. The HA pair in a single chassis has an internal e0S connection, which is used to transfer `var` config between them.
  - For disruptive replacement, you do not need a network connection to restore the `var` file system, but the process requires two reboots.
- You must replace the failed component with a replacement FRU component you received from your provider.
- It is important that you apply the commands in these steps on the correct controller:
  - The *impaired* controller is the controller on which you are performing maintenance.
  - The *healthy* controller is the HA partner of the impaired controller.

### Pre-shutdown checks for onboard encryption keys - ASA A900

Prior to shutting down the impaired controller and checking the status of the onboard encryption keys, you must check the status of the impaired controller, disable automatic giveback, and check which version of ONTAP is running on the system.

If you have a cluster with more than two nodes, it must be in quorum. If the cluster is not in quorum or a healthy controller shows false for eligibility and health, you must correct the issue before shutting down the impaired controller; see the [Synchronize a node with the cluster](#).

## Steps

1. Check the status of the impaired controller:
  - If the impaired controller is at the login prompt, log in as `admin`.
  - If the impaired controller is at the LOADER prompt and is part of HA configuration, log in as `admin` on the healthy controller.



- If the impaired controller is in a standalone configuration and at LOADER prompt, contact [mysupport.netapp.com](http://mysupport.netapp.com).
2. If AutoSupport is enabled, suppress automatic case creation by invoking an AutoSupport message:
 

```
system node autosupport invoke -node * -type all -message
MAINT=number_of_hours_downh
```

The following AutoSupport message suppresses automatic case creation for two hours: `cluster1:*>`

```
system node autosupport invoke -node * -type all -message MAINT=2h
```
  3. Check the version of ONTAP the system is running on the impaired controller if up, or on the partner controller if the impaired controller is down, using the `version -v` command:
    - If <Ino-DARE> or <1Ono-DARE> is displayed in the command output, the system does not support NVE, proceed to shut down the controller.

## ONTAP 9.6 and later

Before shutting down the impaired controller, you need to verify whether the system has either NetApp Volume Encryption (NVE) or NetApp Storage Encryption (NSE) enabled. If so, you need to verify the configuration.

1. Verify whether NVE is in use for any volumes in the cluster: `volume show -is-encrypted true`

If any volumes are listed in the output, NVE is configured and you need to verify the NVE configuration. If no volumes are listed, check whether NSE is configured and in use.

2. Verify whether NSE is configured and in use: `storage encryption disk show`
  - If the command output lists the drive details with Mode & Key ID information, NSE is configured and you need to verify the NSE configuration and in use.
  - If no disks are shown, NSE is not configured.
  - If NVE and NSE are not configured, no drives are protected with NSE keys, it's safe to shut down the impaired controller.

## Verify NVE configuration

1. Display the key IDs of the authentication keys that are stored on the key management servers: `security key-manager key query`



After the ONTAP 9.6 release, you may have additional key manager types. The types are KMIP, AKV, and GCP. The process for confirming these types is the same as confirming external or onboard key manager types.

- If the Key Manager type displays `external` and the Restored column displays `yes`, it's safe to shut down the impaired controller.
- If the Key Manager type displays `onboard` and the Restored column displays `yes`, you need to complete some additional steps.
- If the Key Manager type displays `external` and the Restored column displays anything other than `yes`, you need to complete some additional steps.
- If the Key Manager type displays `onboard` and the Restored column displays anything other than `yes`, you need to complete some additional steps.

2. If the `Key Manager` type displays `onboard` and the `Restored` column displays `yes`, manually back up the OKM information:
  - a. Go to advanced privilege mode and enter `y` when prompted to continue: `set -priv advanced`
  - b. Enter the command to display the key management information: `security key-manager onboard show-backup`
  - c. Copy the contents of the backup information to a separate file or your log file. You'll need it in disaster scenarios where you might need to manually recover OKM.
  - d. Return to admin mode: `set -priv admin`
  - e. Shut down the impaired controller.
  
3. If the `Key Manager` type displays `external` and the `Restored` column displays anything other than `yes`:
  - a. Restore the external key management authentication keys to all nodes in the cluster: `security key-manager external restore`  
  
If the command fails, contact NetApp Support.  
  
[mysupport.netapp.com](https://mysupport.netapp.com)
  - b. Verify that the `Restored` column equals `yes` for all authentication keys: `security key-manager key query`
  - c. Shut down the impaired controller.
  
4. If the `Key Manager` type displays `onboard` and the `Restored` column displays anything other than `yes`:
  - a. Enter the onboard security key-manager sync command: `security key-manager onboard sync`  
  

 Enter the customer's 32 character, alphanumeric onboard key management passphrase at the prompt. If the passphrase cannot be provided, contact NetApp Support.  
[mysupport.netapp.com](https://mysupport.netapp.com)
  - b. Verify the `Restored` column shows `yes` for all authentication keys: `security key-manager key query`
  - c. Verify that the `Key Manager` type shows `onboard`, and then manually back up the OKM information.
  - d. Go to advanced privilege mode and enter `y` when prompted to continue: `set -priv advanced`
  - e. Enter the command to display the key management backup information: `security key-manager onboard show-backup`
  - f. Copy the contents of the backup information to a separate file or your log file. You'll need it in disaster scenarios where you might need to manually recover OKM.
  - g. Return to admin mode: `set -priv admin`
  - h. You can safely shut down the controller.

## Verify NSE configuration

1. Display the key IDs of the authentication keys that are stored on the key management servers: `security key-manager key query -key-type NSE-AK`



After the ONTAP 9.6 release, you may have additional key manager types. The types are KMIP, AKV, and GCP. The process for confirming these types is the same as confirming external or onboard key manager types.

- If the Key Manager type displays `external` and the Restored column displays `yes`, it's safe to shut down the impaired controller.
  - If the Key Manager type displays `onboard` and the Restored column displays `yes`, you need to complete some additional steps.
  - If the Key Manager type displays `external` and the Restored column displays anything other than `yes`, you need to complete some additional steps.
  - If the Key Manager type displays `external` and the Restored column displays anything other than `yes`, you need to complete some additional steps.
2. If the Key Manager type displays `onboard` and the Restored column displays `yes`, manually back up the OKM information:
    - a. Go to advanced privilege mode and enter `y` when prompted to continue: `set -priv advanced`
    - b. Enter the command to display the key management information: `security key-manager onboard show-backup`
    - c. Copy the contents of the backup information to a separate file or your log file. You'll need it in disaster scenarios where you might need to manually recover OKM.
    - d. Return to admin mode: `set -priv admin`
    - e. You can safely shut down the controller.
  3. If the Key Manager type displays `external` and the Restored column displays anything other than `yes`:
    - a. Restore the external key management authentication keys to all nodes in the cluster: `security key-manager external restore`  
  
If the command fails, contact NetApp Support.  
  
[mysupport.netapp.com](https://mysupport.netapp.com)
    - b. Verify that the Restored column equals `yes` for all authentication keys: `security key-manager key query`
    - c. You can safely shut down the controller.
  4. If the Key Manager type displays `onboard` and the Restored column displays anything other than `yes`:
    - a. Enter the onboard security key-manager sync command: `security key-manager onboard sync`  
  
Enter the customer's 32 character, alphanumeric onboard key management passphrase at the prompt. If the passphrase cannot be provided, contact NetApp Support.  
  
[mysupport.netapp.com](https://mysupport.netapp.com)
    - b. Verify the Restored column shows `yes` for all authentication keys: `security key-manager key query`
    - c. Verify that the Key Manager type shows `onboard`, and then manually back up the OKM information.

- d. Go to advanced privilege mode and enter `y` when prompted to continue: `set -priv advanced`
- e. Enter the command to display the key management backup information: `security key-manager onboard show-backup`
- f. Copy the contents of the backup information to a separate file or your log file. You'll need it in disaster scenarios where you might need to manually recover OKM.
- g. Return to admin mode: `set -priv admin`
- h. You can safely shut down the controller.

### **Shut down the impaired controller - ASA A900**

Shut down or take over the impaired controller using the appropriate procedure for your configuration.

## Most configurations

After completing the NVE or NSE tasks, you need to complete the shutdown of the impaired controller.

To shut down the impaired controller, you must determine the status of the controller and, if necessary, take over the controller so that the healthy controller continues to serve data from the impaired controller storage.

### About this task

- If you have a SAN system, you must have checked event messages (`cluster kernel-service show`) for the impaired controller SCSI blade. The `cluster kernel-service show` command (from `priv advanced mode`) displays the node name, quorum status of that node, availability status of that node, and operational status of that node.

Each SCSI-blade process should be in quorum with the other nodes in the cluster. Any issues must be resolved before you proceed with the replacement.

- If you have a cluster with more than two nodes, it must be in quorum. If the cluster is not in quorum or a healthy controller shows false for eligibility and health, you must correct the issue before shutting down the impaired controller; see [Synchronize a node with the cluster](#).

### Steps

1. If AutoSupport is enabled, suppress automatic case creation by invoking an AutoSupport message:  

```
system node autosupport invoke -node * -type all -message MAINT=<# of hours>h
```

The following AutoSupport message suppresses automatic case creation for two hours: `cluster1:>`  

```
system node autosupport invoke -node * -type all -message MAINT=2h
```

2. Disable automatic giveback from the console of the healthy controller: 

```
storage failover modify -node local -auto-giveback false
```



When you see *Do you want to disable auto-giveback?*, enter *y*.

3. Take the impaired controller to the LOADER prompt:

If the impaired controller is displaying...	Then...
The LOADER prompt	Go to the next step.
Waiting for giveback...	Press Ctrl-C, and then respond <i>y</i> when prompted.
System prompt or password prompt	Take over or halt the impaired controller from the healthy controller: <pre>storage failover takeover -ofnode <i>impaired_node_name</i></pre> When the impaired controller shows Waiting for giveback..., press Ctrl-C, and then respond <i>y</i> .

## Controller is in a MetroCluster

After completing the NVE or NSE tasks, you need to complete the shutdown of the impaired controller.



Do not use this procedure if your system is in a two-node MetroCluster configuration.

To shut down the impaired controller, you must determine the status of the controller and, if necessary, take over the controller so that the healthy controller continues to serve data from the impaired controller storage.

- If you have a cluster with more than two nodes, it must be in quorum. If the cluster is not in quorum or a healthy controller shows false for eligibility and health, you must correct the issue before shutting down the impaired controller; see [Synchronize a node with the cluster](#).
- If you have a MetroCluster configuration, you must have confirmed that the MetroCluster Configuration State is configured and that the nodes are in an enabled and normal state (`metrocluster node show`).

### Steps

1. If AutoSupport is enabled, suppress automatic case creation by invoking an AutoSupport message:

```
system node autosupport invoke -node * -type all -message  
MAINT=number_of_hours_downh
```

The following AutoSupport message suppresses automatic case creation for two hours:

```
cluster1:*> system node autosupport invoke -node * -type all -message  
MAINT=2h
```

2. Disable automatic giveback from the console of the healthy controller: `storage failover modify -node local -auto-giveback false`
3. Take the impaired controller to the LOADER prompt:

If the impaired controller is displaying...	Then...
The LOADER prompt	Go to the next step.
Waiting for giveback...	Press Ctrl-C, and then respond <i>y</i> when prompted.
System prompt or password prompt (enter system password)	Take over or halt the impaired controller from the healthy controller: <code>storage failover takeover -ofnode <i>impaired_node_name</i></code>  When the impaired controller shows Waiting for giveback..., press Ctrl-C, and then respond <i>y</i> .

## Replace the boot media - ASA A900

You must remove and open the controller module, locate and replace the boot media in the controller, and then transfer the image to the replacement boot media.

## **Step 1: Remove the controller module**

To access components inside the controller, you must first remove the controller module from the system and then remove the cover on the controller module.

### **Steps**

1. If you are not already grounded, properly ground yourself.
2. Unplug the cables from the impaired controller module, and keep track of where the cables were connected.
3. Slide the terra cotta button on the cam handle downward until it unlocks.

[Animation - Remove the controller](#)

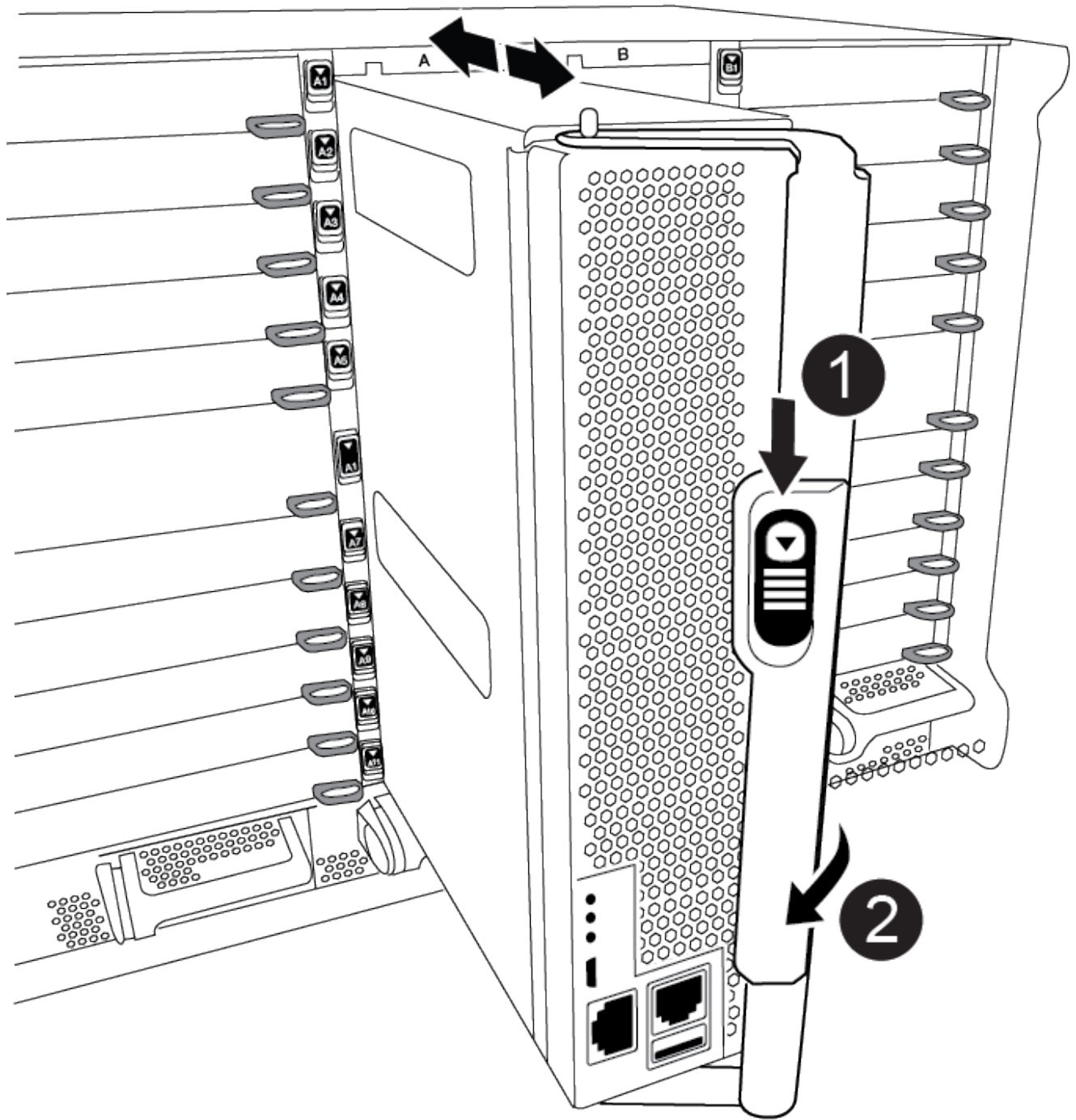

1	Cam handle release button
2	Cam handle

4. Rotate the cam handle so that it completely disengages the controller module from the chassis, and then slide the controller module out of the chassis.

Make sure that you support the bottom of the controller module as you slide it out of the chassis.



5. Place the controller module lid-side up on a stable, flat surface, press the blue button on the cover, slide the cover to the back of the controller module, and then swing the cover up and lift it off of the controller module.

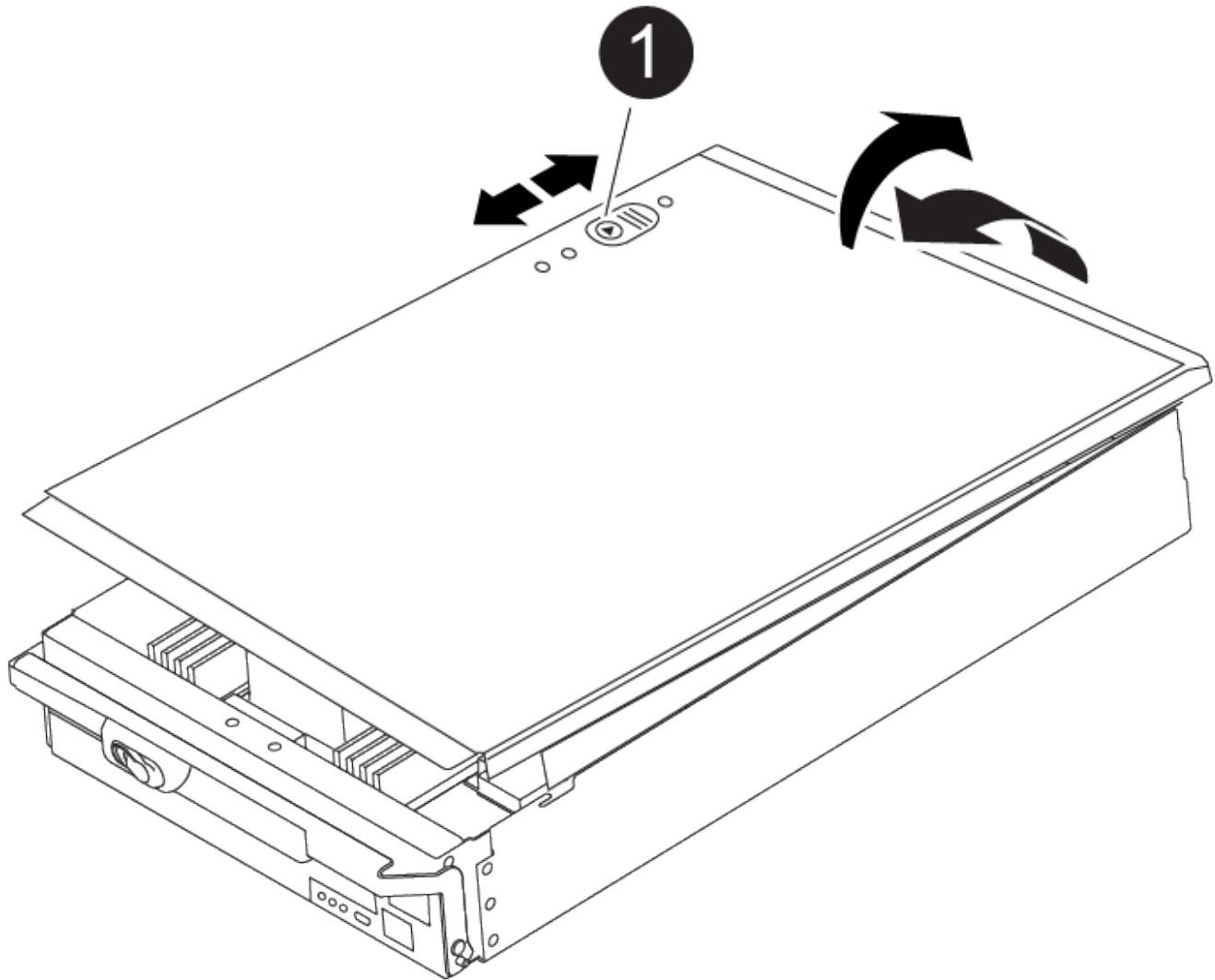

1

Controller module cover locking button

## Step 2: Replace the boot media

You must locate the boot media in the controller and follow the directions to replace it.

### Steps

1. Lift the black air duct at the back of the controller module and then locate the boot media using the following illustration or the FRU map on the controller module:

[Animation - Replace boot media](#)

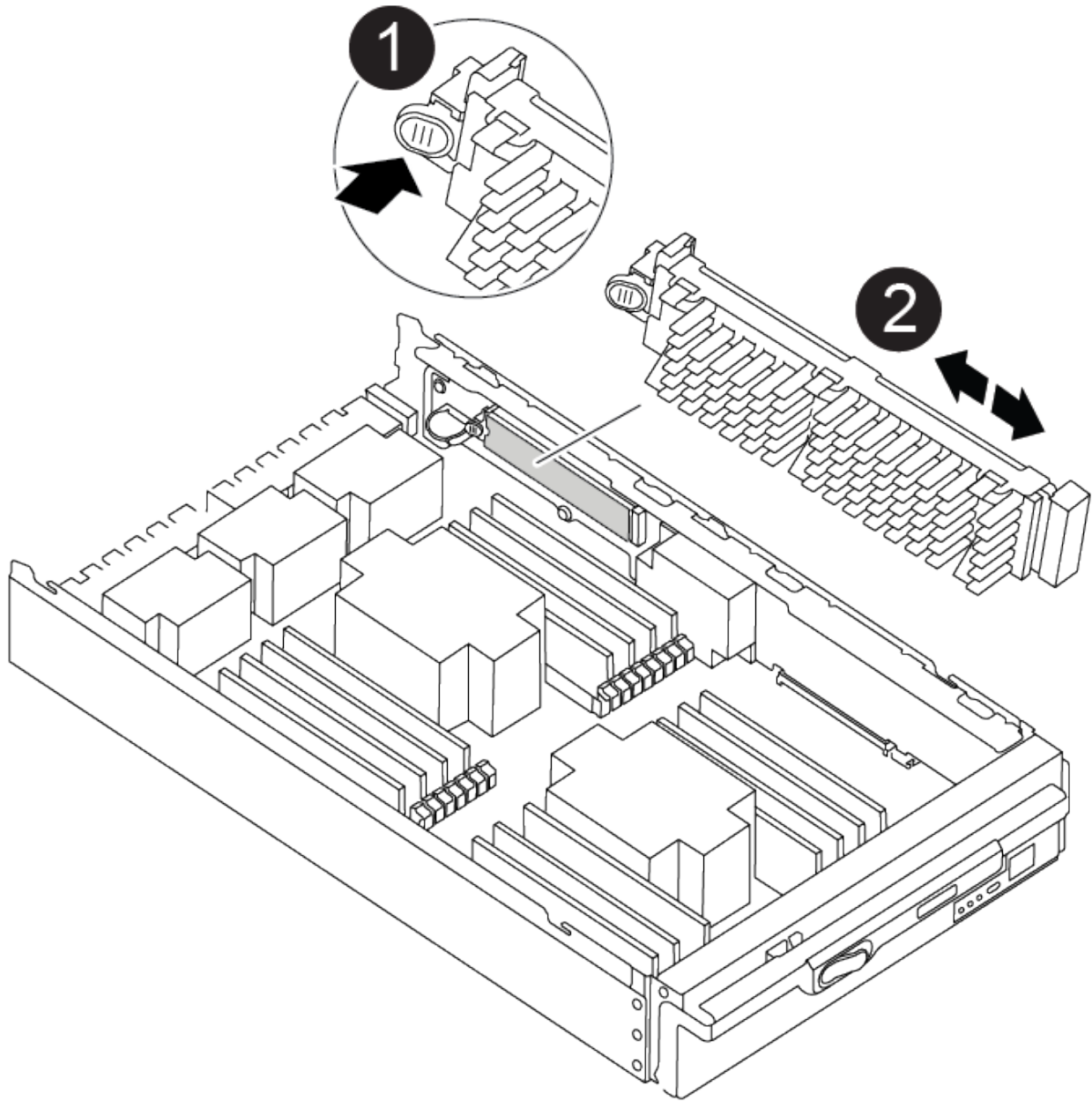

1	Press release tab
2	Boot media

2. Press the blue button on the boot media housing to release the boot media from its housing, and then gently pull it straight out of the boot media socket.



Do not twist or pull the boot media straight up, because this could damage the socket or the boot media.

3. Align the edges of the replacement boot media with the boot media socket, and then gently push it into the socket.

4. Check the boot media to make sure that it is seated squarely and completely in the socket.

If necessary, remove the boot media and reseal it into the socket.

5. Push the boot media down to engage the locking button on the boot media housing.
6. Reinstall the controller module lid by aligning the pins on the lid with the slots on the motherboard carrier, and then slide the lid into place.

### Step 3: Transfer the boot image to the boot media

You can install the system image to the replacement boot media using a USB flash drive with the image installed on it. However, you must restore the var file system during this procedure.

#### Before you begin

- You must have a USB flash drive, formatted to FAT32, with at least 4GB capacity.
- A copy of the same image version of ONTAP as what the impaired controller was running. You can download the appropriate image from the Downloads section on the NetApp Support Site
  - If NVE is enabled, download the image with NetApp Volume Encryption, as indicated in the download button.
  - If NVE is not enabled, download the image without NetApp Volume Encryption, as indicated in the download button.
- If your system is a stand-alone system you do not need a network connection, but you must perform an additional reboot when restoring the var file system.

#### Steps

1. Align the end of the controller module with the opening in the chassis, and then gently push the controller module halfway into the system.
2. Recable the controller module, as needed.
3. Insert the USB flash drive into the USB slot on the controller module.

Make sure that you install the USB flash drive in the slot labeled for USB devices, and not in the USB console port.

4. Push the controller module all the way into the system, making sure that the cam handle clears the USB flash drive, firmly push the cam handle to finish seating the controller module, and then push the cam handle to the closed position.

The controller begins to boot as soon as it is completely installed into the chassis.

5. Interrupt the boot process to stop at the LOADER prompt by pressing Ctrl-C when you see Starting AUTOBOOT press Ctrl-C to abort....

If you miss this message, press Ctrl-C, select the option to boot to Maintenance mode, and then halt the controller to boot to LOADER.

6. Set your network connection type at the LOADER prompt:

- If you are configuring DHCP: `ifconfig e0a -auto`



The target port you configure is the target port you use to communicate with the impaired controller from the healthy controller during var file system restore with a network connection. You can also use the e0M port in this command.

◦ If you are configuring manual connections: `ifconfig e0a -addr=filer_addr -mask=netmask -gw=gateway-dns=dns_addr-domain=dns_domain`

- `filer_addr` is the IP address of the storage system.
- `netmask` is the network mask of the management network that is connected to the HA partner.
- `gateway` is the gateway for the network.
- `dns_addr` is the IP address of a name server on your network.
- `dns_domain` is the Domain Name System (DNS) domain name.

If you use this optional parameter, you do not need a fully qualified domain name in the netboot server URL. You need only the server's host name.



Other parameters might be necessary for your interface. You can enter `help ifconfig` at the firmware prompt for details.

7. If the controller is in a stretch or fabric-attached MetroCluster, you must restore the FC adapter configuration:

- a. Boot to Maintenance mode: `boot_ontap maint`
- b. Set the MetroCluster ports as initiators: `ucadmin modify -m fc -t initiator adapter_name`
- c. Halt to return to Maintenance mode: `halt`

The changes will be implemented when the system is booted.

### Boot the recovery image - ASA A900

You must boot the ONTAP image from the USB drive, restore the file system, and verify the environmental variables.

1. From the LOADER prompt, boot the recovery image from the USB flash drive: `boot_recovery`

The image is downloaded from the USB flash drive.

2. When prompted, either enter the name of the image or accept the default image displayed inside the brackets on your screen.

3. Restore the var file system:

If your system has...	Then...
A network connection	<ul style="list-style-type: none"> <li>a. Press <code>y</code> when prompted to restore the backup configuration.</li> <li>b. Press <code>y</code> when prompted to overwrite <code>/etc/ssh/ssh_host_ecdsa_key</code>.</li> <li>c. Press <code>y</code> when prompted to confirm if the restore backup was successful.</li> <li>d. Press <code>Y</code> when prompted to the restored configuration copy.</li> <li>e. Set the impaired controller to advanced privilege level: <code>set -privilege advanced</code></li> <li>f. Run the restore backup command: <code>system node restore-backup -node local -target-address impaired_node_IP_address</code></li> <li>g. Return the impaired controller to admin level: <code>set -privilege admin</code></li> <li>h. Press <code>y</code> when prompted to use the restored configuration.</li> <li>i. Press <code>y</code> when prompted to reboot the impaired controller.</li> </ul>
No network connection	<ul style="list-style-type: none"> <li>a. Press <code>n</code> when prompted to restore the backup configuration.</li> <li>b. Reboot the system when prompted by the system.</li> <li>c. Select the <b>Update flash from backup config</b> (sync flash) option from the displayed menu.</li> </ul> <p>If you are prompted to continue with the update, press <code>y</code>.</p>

If your system has...	Then...
No network connection and is in a MetroCluster IP configuration	<p>a. Press <code>n</code> when prompted to restore the backup configuration.</p> <p>b. Reboot the system when prompted by the system.</p> <p>c. Wait for the iSCSI storage connections to connect.</p> <p>You can proceed after you see the following messages:</p> <pre data-bbox="672 394 1489 1255"> date-and-time [node- name:iscsi.session.stateChanged:notice]: iSCSI session state is changed to Connected for the target iSCSI-target (type: dr_auxiliary, address: ip-address). date-and-time [node- name:iscsi.session.stateChanged:notice]: iSCSI session state is changed to Connected for the target iSCSI-target (type: dr_partner, address: ip-address). date-and-time [node- name:iscsi.session.stateChanged:notice]: iSCSI session state is changed to Connected for the target iSCSI-target (type: dr_auxiliary, address: ip-address). date-and-time [node- name:iscsi.session.stateChanged:notice]: iSCSI session state is changed to Connected for the target iSCSI-target (type: dr_partner, address: ip-address). </pre> <p>d. Select the <b>Update flash from backup config</b> (sync flash) option from the displayed menu.</p> <p>If you are prompted to continue with the update, press <code>y</code>.</p>

4. Ensure that the environmental variables are set as expected:
  - a. Take the impaired controller to the LOADER prompt.
  - b. Check the environment variable settings with the `printenv` command.
  - c. If an environment variable is not set as expected, modify it with the `setenv environment_variable_name changed_value` command.
  - d. Save your changes using the `saveenv` command.
5. The next depends on your system configuration:
  - If your system has onboard keymanager, NSE or NVE configured, go to [Post boot media replacement steps for OKM, NSE, and NVE](#)

- If your system does not have onboard keymanager, NSE or NVE configured, complete the steps in this section.

6. From the LOADER prompt, enter the boot\_ontap command.

If you see...	Then...
The login prompt	Go to the next Step.
Waiting for giveback...	a. Log into the partner controller. b. Confirm the target is ready for giveback with the <code>storage failover show</code> command.

7. Connect the console cable to the partner controller.
8. Give back the controller using the `storage failover giveback -fromnode local` command.
9. At the cluster prompt, check the logical interfaces with the `net int -is-home false` command.

If any interfaces are listed as "false", revert those interfaces back to their home port using the `net int revert` command.

10. Move the console cable to the repaired Shut down or take over the impaired controller using the appropriate procedure for your configuration. and run the `version -v` command to check the ONTAP versions.
11. Restore automatic giveback if you disabled it by using the `storage failover modify -node local -auto -giveback true` command.

### Post boot media replacement steps for OKM, NSE, and NVE - ASA A900

After environment variables are checked, you must complete steps specific to restore Onboard Key Manager (OKM), NetApp Storage Encryption (NSE) and NetApp Volume Encryption (NVE).

Determine which section you should use to restore your OKM, NSE, or NVE configurations: If NSE or NVE are enabled along with Onboard Key Manager you must restore settings you captured at the beginning of this procedure.

- If NSE or NVE are enabled and Onboard Key Manager is enabled, go to [Restore NVE or NSE when Onboard Key Manager is enabled](#).
- If NSE or NVE are enabled for ONTAP 9.6, go to [Restore NSE/NVE on systems running ONTAP 9.6 and later](#).

### Restore NVE or NSE when Onboard Key Manager is enabled

#### Steps

1. Connect the console cable to the target controller.
2. Use the boot\_ontap command at the LOADER prompt to boot the controller.
3. Check the console output:

If the console displays...	Then...
The LOADER prompt	Boot the controller to the boot menu: <code>boot_ontap menu</code>
Waiting for giveback....	<ol style="list-style-type: none"> <li>Enter <code>Ctrl-C</code> at the prompt</li> <li>At the message: Do you wish to halt this node rather than wait [y/n]? , enter: <code>y</code></li> <li>At the LOADER prompt, enter the <code>boot_ontap menu</code> command.</li> </ol>

- At the Boot Menu, enter the hidden command, `recover_onboard_keymanager`, and reply `y` at the prompt.
- Enter the passphrase for the onboard key manager you obtained from the customer at the beginning of this procedure.
- When prompted to enter the backup data, paste the backup data you captured at the beginning of this section, when asked. Paste the output of `security key-manager backup show` OR `security key-manager onboard show-backup` command.



The data is output from either `security key-manager backup show` or `security key-manager onboard show-backup`` command.

Example of backup data:

Enter the backup data:

```

-----BEGIN BACKUP-----
TmV0QXBwIEtleSBCbG9iAAEAAAAEAAAAcAEAAAAAADuD+byAAAAACEAAAAAAAA
QAAAAAAAAABvOIH0AAAAAMh7qDLRyH1DBz12piVdy9ATSFMT0C0TIYFss4PDjTaV
dzRYkLd1PhQLxAWJwOlyqSr8qY1SEBgm1IWgE5DLRqkiAAAAAAAAACgAAAAAAAA
3WTh7gAAAAAAAAAAAAAAAAAIAAAAAAAgAZJEIWvdeHr5RCAvHGclo+wAAAAAAAA
lgAAAAAAAAAoAAAAAAAAAEOTcR0AAAAAAAAAAAAAAAAACAAAAAAAAJAGr3tJA/
LRzUQRHwv+1aWvAAAAAAAAAACQAAAAAAAAAgAAAAAAAAACdhTcvAAAAAJ1PXeBf
ml4NBsSyV1B4jc4A7cvWEFY6ILG6hc6tbKLAHZuvfQ4rlbYAAAAAAAAAAAAAAAA
AAAAAAAAAAAAAAAAAAAAAAAAAAAAAAAAAAAAAAAAAAAAAAAAAAAAAAAAAAAAAAAA
AAAAAAAAAAAAAAAAAAAAAAAAAAAAAAAAAAAAAAAAAAAAAAAAAAAAAAAAAAAAAAAA
.
.
.
.
H4nPQM0nrDRYRa9SCv8AAAAAAAAAAAAAAAAAAAAAAAAAAAAAAAAAAAAAAAAAAAA
AAAAAAAAAAAAAAAAAAAAAAAAAAAAAAAAAAAAAAAAAAAAAAAAAAAAAAAAAAAAAAAA
AAAAAAA
-----END BACKUP-----

```

- At the Boot Menu select the option for Normal Boot.

The system boots to Waiting for giveback... prompt.



8. Move the console cable to the partner controller and log in as admin.
9. Confirm the target controller is ready for giveback with the `storage failover show` command.
10. Give back only the CFO aggregates with the `storage failover giveback -fromnode local -only-cfo-aggregates true` command.
  - If the command fails because of a failed disk, physically disengage the failed disk, but leave the disk in the slot until a replacement is received.
  - If the command fails because of an open CIFS session, check with the customer how to close out CIFS sessions.



Terminating CIFS can cause loss of data.

- If the command fails because the partner "not ready", wait 5 minutes for the NVRAMs to synchronize.
  - If the command fails because of an NDMP, SnapMirror, or SnapVault process, disable the process. See the appropriate content for more information.
11. Once the giveback completes, check the failover and giveback status with the `storage failover show` and `storage failover show-giveback` commands.

Only the CFO aggregates (root aggregate and CFO style data aggregates) will be shown.

12. If you are running ONTAP 9.6 or later, run the security key-manager onboard sync:
  - a. Run the `security key-manager onboard sync` command and then enter the passphrase when prompted.
  - b. Enter the `security key-manager key-query` command to see a detailed view of all keys stored in the onboard key manager and verify that the `Restored` column = `yes/true` for all authentication keys.



If the `Restored` column = anything other than `yes/true`, contact Customer Support.

- c. Wait 10 minutes for the key to synchronize across the cluster.
13. Move the console cable to the partner controller.
14. Give back the target controller using the `storage failover giveback -fromnode local` command.
15. Check the giveback status, three minutes after it reports complete, using the `storage failover show` command.

If giveback is not complete after 20 minutes, contact Customer Support.

16. At the clustershell prompt, enter the `net int show -is-home false` command to list the logical interfaces that are not on their home controller and port.

If any interfaces are listed as `false`, revert those interfaces back to their home port using the `net int revert -vserver Cluster -lif nodename` command.

17. Move the console cable to the target controller and run the `version -v` command to check the ONTAP versions.
18. Restore automatic giveback if you disabled it by using the `storage failover modify -node local -auto-giveback true` command.

## Restore NSE/NVE on systems running ONTAP 9.6 and later

### Steps

1. Connect the console cable to the target controller.
2. Use the `boot_ontap` command at the LOADER prompt to boot the controller.
3. Check the console output:

If the console displays...	Then...
The login prompt	Go to step 7.
Waiting for giveback...	<ol style="list-style-type: none"><li>a. Log into the partner controller.</li><li>b. Confirm the target controller is ready for giveback with the <code>storage failover show</code> command.</li></ol>

4. Move the console cable to the partner controller and give back the target controller storage using the `storage failover giveback -fromnode local -only-cfo-aggregates true local` command.
  - If the command fails because of a failed disk, physically disengage the failed disk, but leave the disk in the slot until a replacement is received.
  - If the command fails because of an open CIFS sessions, check with customer how to close out CIFS sessions.



Terminating CIFS can cause loss of data.

- If the command fails because the partner is "not ready", wait 5 minutes for the NVMEMs to synchronize.
  - If the command fails because of an NDMP, SnapMirror, or SnapVault process, disable the process. See the appropriate content for more information.
5. Wait 3 minutes and check the failover status with the `storage failover show` command.
  6. At the clustershell prompt, enter the `net int show -is-home false` command to list the logical interfaces that are not on their home controller and port.

If any interfaces are listed as `false`, revert those interfaces back to their home port using the `net int revert -vserver Cluster -lif nodename` command.

7. Move the console cable to the target controller and run the `version -v` command to check the ONTAP versions.
8. Restore automatic giveback if you disabled it by using the `storage failover modify -node local -auto-giveback true` command.
9. Use the `storage encryption disk show` at the clustershell prompt, to review the output.
10. Use the `security key-manager key-query` command to display the encryption and authentication keys that are stored on the key management servers.
  - If the `Restored` column = `yes/true`, you are done and can proceed to complete the replacement process.
  - If the `Key Manager type` = `external` and the `Restored` column = anything other than `yes/true`, use the `security key-manager external restore` command to restore the key IDs of the

authentication keys.



If the command fails, contact Customer Support.

- If the `Key Manager type = onboard` and the `Restored` column = anything other than `yes/true`, use the `security key-manager onboard sync` command to re-sync the Key Manager type.

Use the `security key-manager key-query` command to verify that the `Restored` column = `yes/true` for all authentication keys.

11. Connect the console cable to the partner controller.
12. Give back the controller using the `storage failover giveback -fromnode local` command.
13. Restore automatic giveback if you disabled it by using the `storage failover modify -node local -auto-giveback true` command.

### Return the failed part to NetApp - ASA A900

Return the failed part to NetApp, as described in the RMA instructions shipped with the kit. See the [Part Return and Replacements](#) page for further information.

### Chassis

#### Replace the chassis - ASA A900

To replace the chassis, you must remove the power supplies, fans, controller modules, I/O modules, DCPM modules, and USB LED module from the impaired chassis, remove the impaired chassis from the equipment rack or system cabinet, install the replacement chassis in its place, and then install the components into the replacement chassis.

All other components in the system must be functioning properly; if not, you must contact technical support.

- You can use this procedure with all versions of ONTAP supported by your system.
- This procedure is disruptive. For a two-node cluster, you will have a complete service outage and a partial outage in a multi-node cluster.

#### Shutdown the controllers - ASA A900

This procedure is for 2-node, non-MetroCluster configurations only. If you have a system with more than two nodes, see [How to perform a graceful shutdown and power up of one HA pair in a 4-node cluster](#).

#### Before you begin

You need:

- Local administrator credentials for ONTAP.
- NetApp onboard key management (OKM) cluster-wide passphrase if using storage encryption or NVE/NAE.
- BMC accessibility for each controller.

- Stop all clients/host from accessing data on the NetApp system.
- Suspend external backup jobs.
- Necessary tools and equipment for the replacement.



If the system is a NetApp StorageGRID or ONTAP S3 used as FabricPool cloud tier, refer to the [Gracefully shutdown and power up your storage system Resolution Guide](#) after performing this procedure.



If using SSDs, refer to [SU490: \(Impact: Critical\) SSD Best Practices: Avoid risk of drive failure and data loss if powered off for more than two months](#)

As a best practice before shutdown, you should:

- Perform additional [system health checks](#).
- Upgrade ONTAP to a recommended release for the system.
- Resolve any [Active IQ Wellness Alerts and Risks](#).  
Make note of any faults presently on the system, such as LEDs on the system components.

### Steps

1. Log into the cluster through SSH or log in from any node in the cluster using a local console cable and a laptop/console.
2. Turn off AutoSupport and indicate how long you expect the system to be offline:

```
system node autosupport invoke -node * -type all -message "MAINT=8h Power Maintenance"
```

3. Identify the SP/BMC address of all nodes:

```
system service-processor show -node * -fields address
```

4. Exit the cluster shell: `exit`
5. Log into SP/BMC over SSH using the IP address of any of the nodes listed in the output from the previous step.

If you're using a console/laptop, log into the controller using the same cluster administrator credentials.



Open an SSH session to every SP/BMC connection so that you can monitor progress.

6. Halt the 2 nodes located in the impaired chassis:

```
system node halt -node <node>,<node2> -skip-lif-migration-before-shutdown true -ignore-quorum-warnings true -inhibit-takeover true
```



For clusters using SnapMirror synchronous operating in StrictSync mode: `system node halt -node <node>,<node2> -skip-lif-migration-before-shutdown true -ignore-quorum-warnings true -inhibit-takeover true -ignore-strict -sync-warnings true`

7. Enter **y** for each controller in the cluster when you see *Warning: Are you sure you want to halt*

```
node "cluster <node-name> number"?  
{y|n}:
```

8. Wait for each controller to halt and display the LOADER prompt.

## Move and replace hardware - ASA A900

To replace the chassis, you must remove the components from the impaired chassis and install them in the replacement chassis.

### Step 1: Remove the power supplies

Removing the power supplies when replacing a chassis involves turning off, disconnecting, and then removing the four power supplies from the rear of the impaired chassis.

1. If you are not already grounded, properly ground yourself.
2. Turn off the power supply and disconnect the power cables:
  - a. Turn off the power switch on the power supply.
  - b. Open the power cable retainer, and then unplug the power cable from the power supply.
  - c. Unplug the power cable from the power source.
3. Press and hold the terra cotta locking button on the power supply handle, and then pull the power supply out of the chassis.



When removing a power supply, always use two hands to support its weight.

### Animation - Remove/install PSU

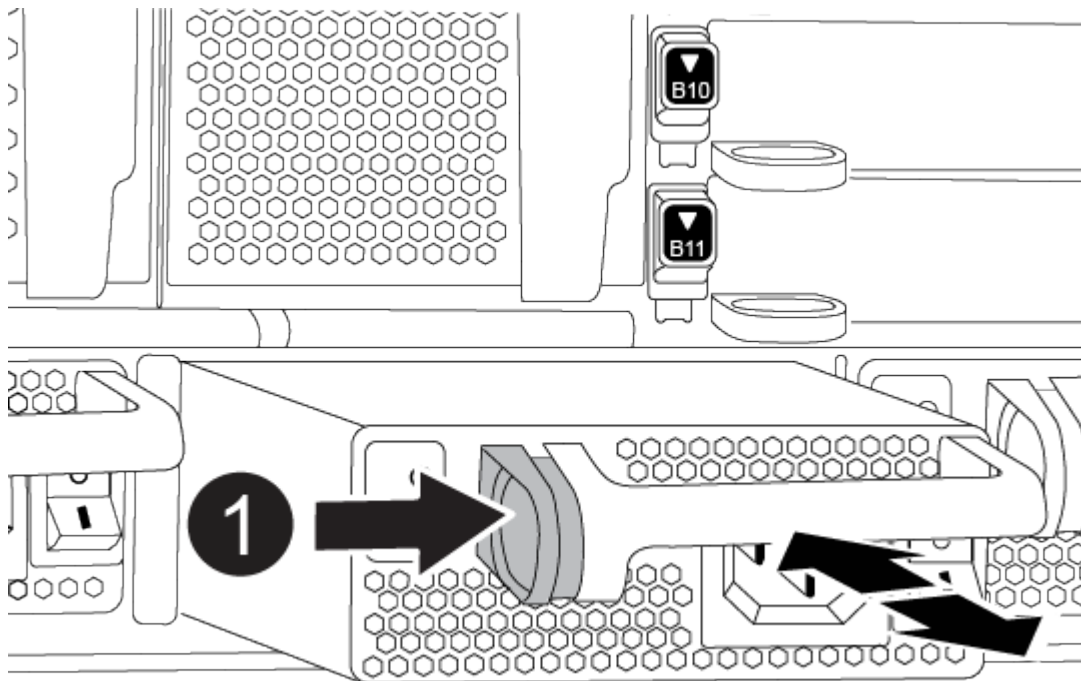

1

Locking button

4. Repeat the preceding steps for any remaining power supplies.

## Step 2: Remove the fans

You must remove the six fan modules, located on in the front of the chassis, when replacing the chassis.

1. If you are not already grounded, properly ground yourself.
2. Remove the bezel (if necessary) with two hands, by grasping the openings on each side of the bezel, and then pulling it toward you until the bezel releases from the ball studs on the chassis frame.
3. Press the terra cotta locking button on the fan module and pull the fan module straight out of the chassis, making sure that you support it with your free hand.



The fan modules are short. Always support the bottom of the fan module with your free hand so that it does not suddenly drop free from the chassis and injure you.

### Animation - Remove/install fan

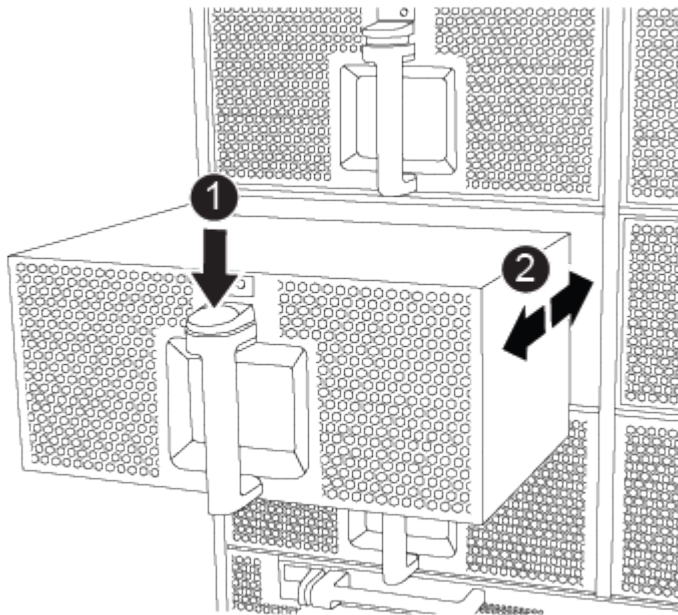

1	Terra cotta locking button
2	Slide fan in/out of chassis

4. Set the fan module aside.
5. Repeat the preceding steps for any remaining fan modules.

## Step 3: Remove the controller module

To replace the chassis, you must remove the controller module or modules from the impaired chassis.

1. If you are not already grounded, properly ground yourself.
2. Unplug the cables from the impaired controller module, and keep track of where the cables were

connected.

3. Slide the terra cotta locking button on the cam handle downward until it unlocks.

Animation - Remove the controller

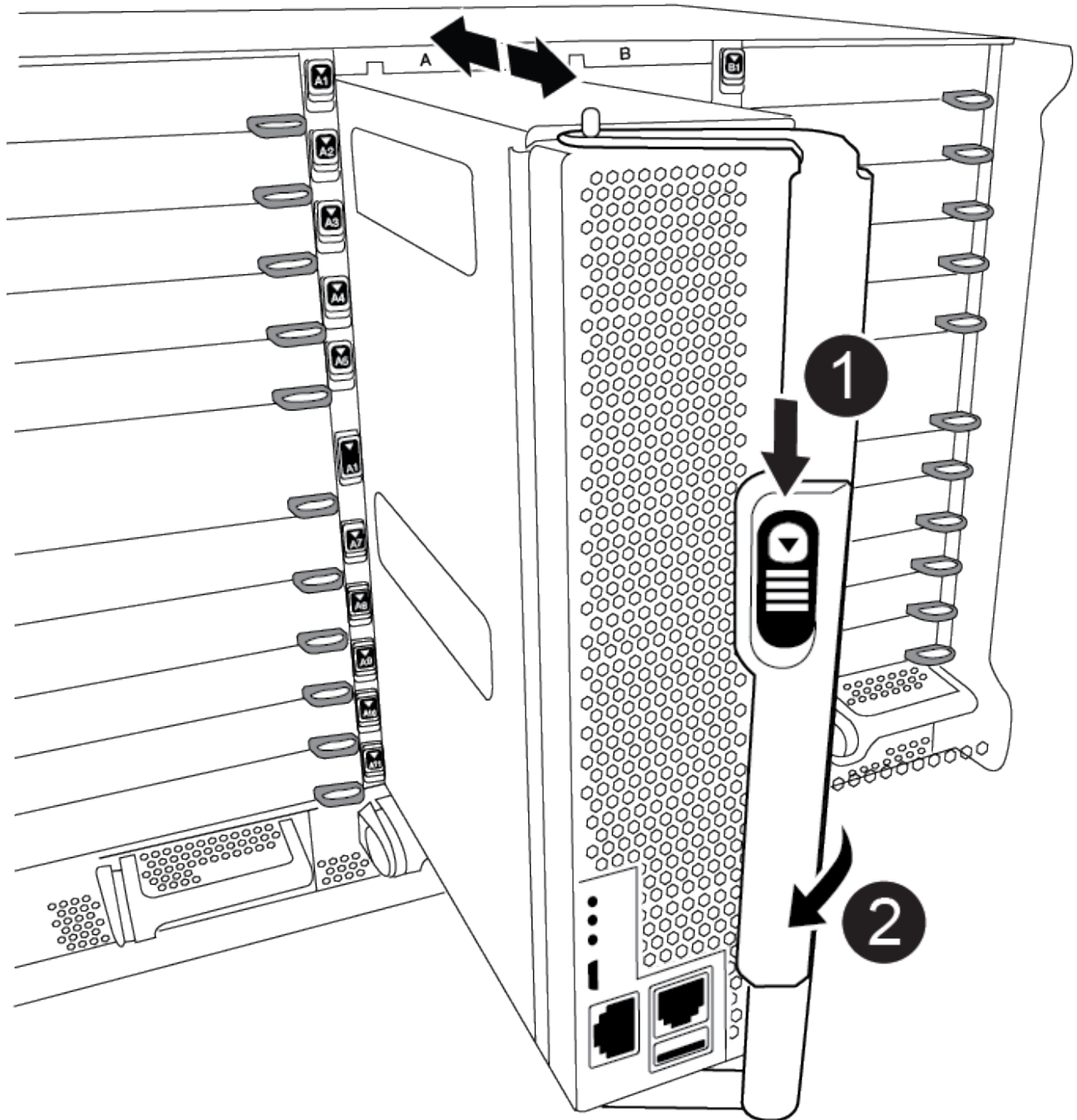

1	Cam handle locking button
2	Cam handle

4. Rotate the cam handle so that it completely disengages the controller module from the chassis, and then slide the controller module out of the chassis.

Make sure that you support the bottom of the controller module as you slide it out of the chassis.

5. Set the controller module aside in a safe place and keep track of which chassis slot it came from, so that it can be installed into the same slot in the replacement chassis..
6. Repeat these steps if you have another controller module in the chassis.

#### **Step 4: Remove the I/O modules**

To remove I/O modules from the impaired chassis, including the NVRAM modules, follow the specific sequence of steps.

1. If you are not already grounded, properly ground yourself.
2. Unplug any cabling associated with the target I/O module.

Make sure that you label the cables so that you know where they came from.

3. Remove the target I/O module from the chassis:

- a. Depress the lettered and numbered cam locking button.

The cam locking button moves away from the chassis.

- b. Rotate the cam latch down until it is in a horizontal position.

The I/O module disengages from the chassis and moves about 1/2 inch out of the I/O slot.

- c. Remove the I/O module from the chassis by pulling on the pull tabs on the sides of the module face.

Make sure that you keep track of which slot the I/O module was in.

[Animation - Remove/install I/O module](#)



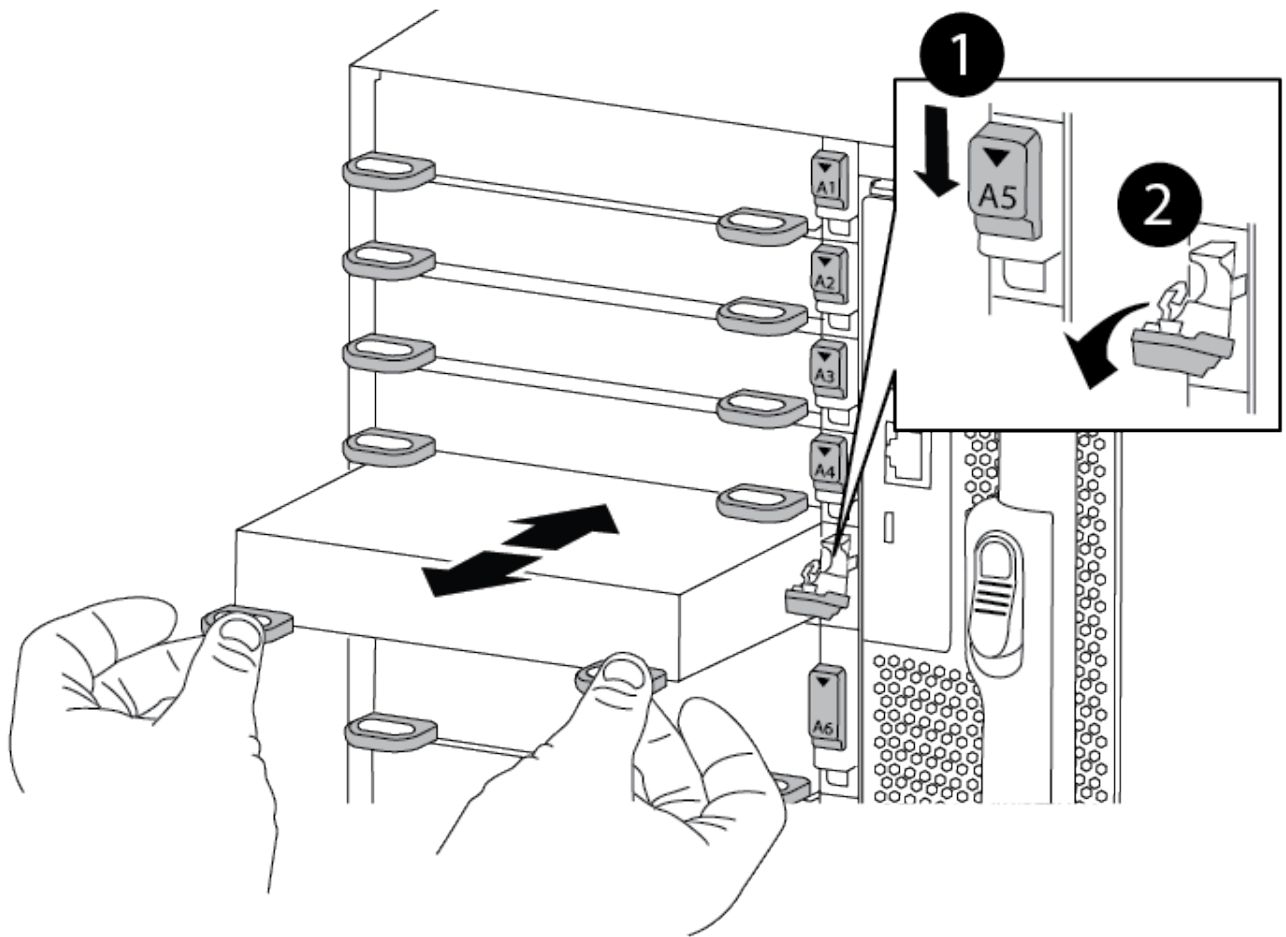

1	Lettered and numbered I/O cam latch
2	I/O cam latch completely unlocked

4. Set the I/O module aside.
5. Repeat the preceding step for the remaining I/O modules in the impaired chassis.

### Step 5: Remove the de-stage controller power module

Remove the two de-stage controller power modules from the front of the impaired chassis.

1. If you are not already grounded, properly ground yourself.
2. Press the terra cotta locking button on the module handle, and then slide the DCPM out of the chassis.

[Animation - Remove/install DCPM](#)

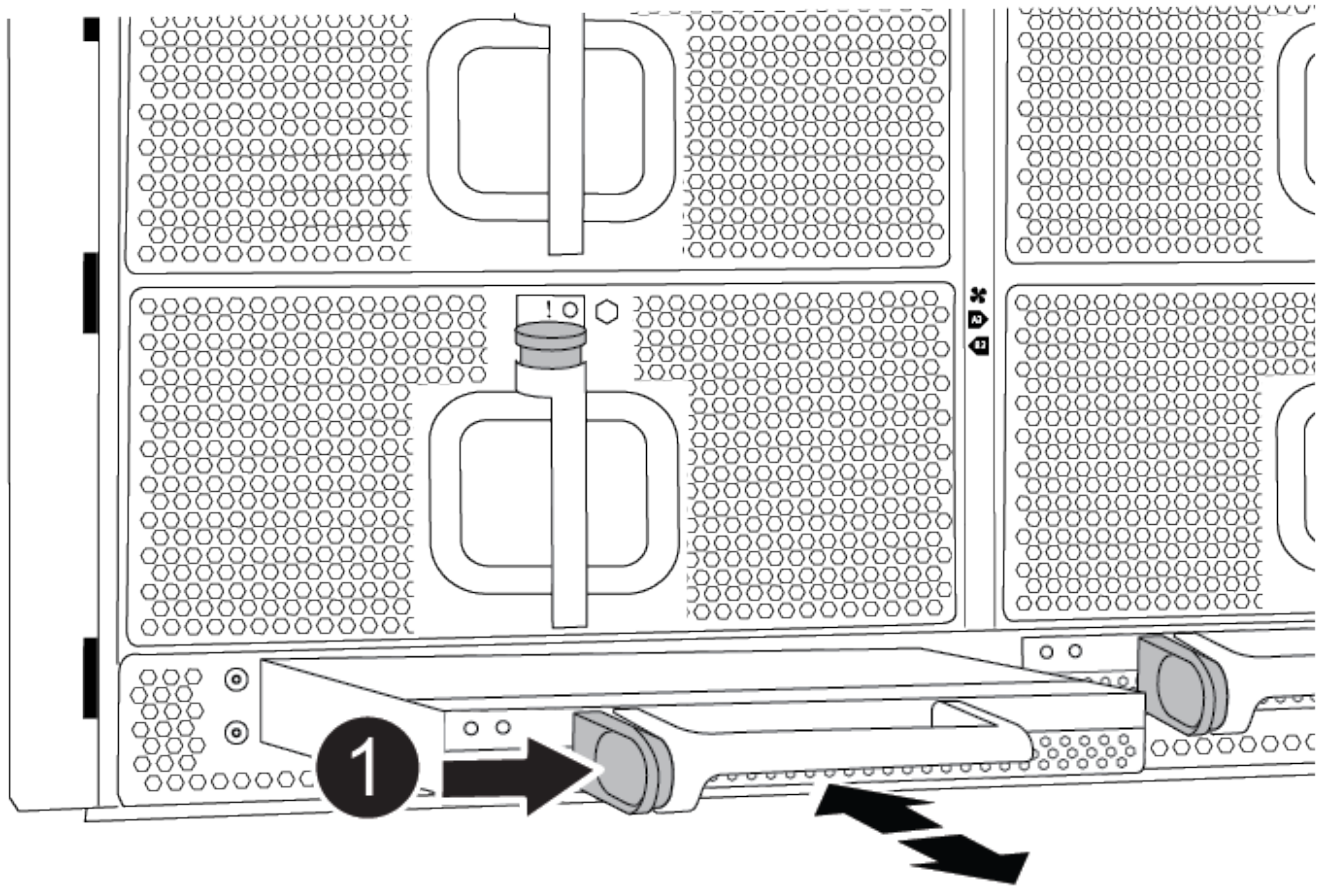

1	DCPM terra cotta locking button
---	---------------------------------

3. Set the DCPM aside in a safe place and repeat this step for the remaining DCPM.

### Step 6: Remove the USB LED module

Remove the USB LED modules.

[Animation - Remove/install USB](#)

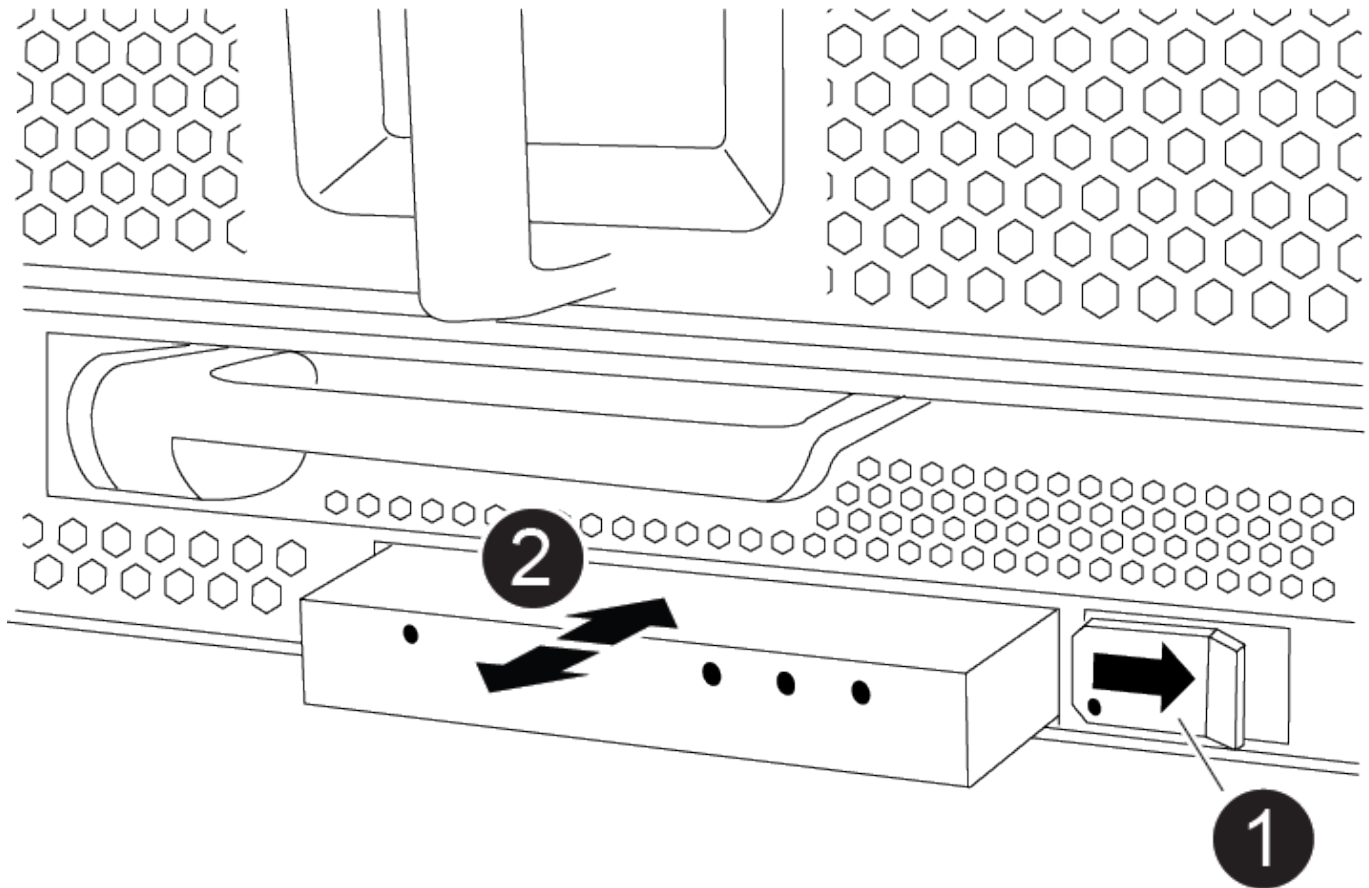

1	Eject the module.
2	Slide out of chassis.

1. Locate the USB LED module on the front of the impaired chassis, directly under the DCPM bays.
2. Press the black locking button on the right side of the module to release the module from the chassis, and then slide it out of the impaired chassis.
3. Set the module aside in a safe place.

### Step 7: Remove chassis

You must remove the existing chassis from the equipment rack or system cabinet before you can install the replacement chassis.

1. Remove the screws from the chassis mount points.



If the system is in a system cabinet, you might need to remove the rear tie-down bracket.

2. With the help of two or three people, slide the impaired chassis off the rack rails in a system cabinet or L brackets in an equipment rack, and then set it aside.
3. If you are not already grounded, properly ground yourself.

4. Using two or three people, install the replacement chassis into the equipment rack or system cabinet by guiding the chassis onto the rack rails in a system cabinet or L brackets in an equipment rack.
5. Slide the chassis all the way into the equipment rack or system cabinet.
6. Secure the front of the chassis to the equipment rack or system cabinet, using the screws you removed from the impaired chassis.
7. Secure the rear of the chassis to the equipment rack or system cabinet.
8. If you are using the cable management brackets, remove them from the impaired chassis, and then install them on the replacement chassis.

### Step 8: Install the de-stage controller power module

When the replacement chassis is installed into the rack or system cabinet, you must reinstall the de-stage controller power modules into it.

1. If you are not already grounded, properly ground yourself.
2. Align the end of the DCPM with the chassis opening, and then gently slide it into the chassis until it clicks into place.



The module and slot are keyed. Do not force the module into the opening. If the module does not go in easily, realign the module and slide it into the chassis.

3. Repeat this step for the remaining DCPM.

### Step 9: Install fans into the chassis

To install the fan modules when replacing the chassis, you must perform a specific sequence of tasks.

1. If you are not already grounded, properly ground yourself.
2. Align the edges of the replacement fan module with the opening in the chassis, and then slide it into the chassis until it snaps into place.

When inserted into a live system, the amber Attention LED flashes four times when the fan module is successfully inserted into the chassis.

3. Repeat these steps for the remaining fan modules.
4. Align the bezel with the ball studs, and then gently push the bezel onto the ball studs.

### Step 10: Install I/O modules

To install I/O modules, including the NVRAM modules from the impaired chassis, follow the specific sequence of steps.

You must have the chassis installed so that you can install the I/O modules into the corresponding slots in the replacement chassis.

1. If you are not already grounded, properly ground yourself.
2. After the replacement chassis is installed in the rack or cabinet, install the I/O modules into their corresponding slots in the replacement chassis by gently sliding the I/O module into the slot until the lettered and numbered I/O cam latch begins to engage, and then push the I/O cam latch all the way up to lock the module in place.

3. Recable the I/O module, as needed.
4. Repeat the preceding step for the remaining I/O modules that you set aside.



If the impaired chassis has blank I/O panels, move them to the replacement chassis at this time.

### Step 11: Install the power supplies

Installing the power supplies when replacing a chassis involves installing the power supplies into the replacement chassis, and connecting to the power source.

1. If you are not already grounded, properly ground yourself.
2. Make sure the power supplies rockers are in the off position.
3. Using both hands, support and align the edges of the power supply with the opening in the system chassis, and then gently push the power supply into the chassis until it locks into place.

The power supplies are keyed and can only be installed one way.



Do not use excessive force when sliding the power supply into the system. You can damage the connector.

4. Reconnect the power cable and secure it to the power supply using the power cable locking mechanism.



Only connect the power cable to the power supply. Do not connect the power cable to a power source at this time.

5. Repeat the preceding steps for any remaining power supplies.

### Step 12: Install the USB LED modules

Install the USB LED modules in the replacement chassis.

1. Locate the USB LED module slot on the front of the replacement chassis, directly under the DCPM bays.
2. Align the edges of the module with the USB LED bay, and gently push the module all the way into the chassis until it clicks into place.

### Step 13: Install the controller

After you install the controller module and any other components into the replacement chassis, boot it.

1. If you are not already grounded, properly ground yourself.
2. Connect the power supplies to different power sources, and then turn them on.
3. Align the end of the controller module with the opening in the chassis, and then gently push the controller module halfway into the system.



Do not completely insert the controller module in the chassis until instructed to do so.

4. Recable the console to the controller module, and then reconnect the management port.
5. With the cam handle in the open position, slide the controller module into the chassis and firmly push the

controller module in until it meets the midplane and is fully seated, and then close the cam handle until it clicks into the locked position.



Do not use excessive force when sliding the controller module into the chassis; you might damage the connectors.

The controller module begins to boot as soon as it is fully seated in the chassis.

6. Repeat the preceding steps to install the second controller into the replacement chassis.
7. Boot each controller.

## Restore and verify the configuration - ASA A900

To complete the chassis replacement, you must complete specific tasks.

### Step 1: Verify and set the HA state of the chassis

You must verify the HA state of the chassis, and, if necessary, update the state to match your system configuration.

1. In Maintenance mode, from either controller module, display the HA state of the local controller module and chassis: `ha-config show`

The HA state should be the same for all components.

2. If the displayed system state for the chassis does not match your system configuration:
  - a. Set the HA state for the chassis: `ha-config modify chassis ha-state`

The value for HA-state can be one of the following:

- ha
- non-ha

3. Confirm that the setting has changed: `ha-config show`
4. If you have not already done so, recable the rest of your system.

### Step 2: Bring up the system

1. If you have not done so, plug the power cables back into the PSUs.
2. Turn on the PSUs by toggling the rocker switched to **ON**, and wait for the controllers to power up completely.
3. Check the front and the back of the chassis and controllers for any fault lights after power up.
4. Connect to the SP or BMC IP address of the nodes via SSH. This will be the same address used to shut down the nodes.
5. Perform additional health checks as described in [How\\_to\\_perform\\_a\\_cluster\\_health\\_check\\_with\\_a\\_script\\_in\\_ONTAP](#)
6. Turn AutoSupport back on (end the maintenance window message):  
`system node autosupport invoke -node * -type all -message MAINT=end`



As a best practice, you should do the following:

- Resolve any [Active IQ Wellness Alerts and Risks](#) (Active IQ will take time to process post-power up AutoSupports - expect a delay in results)
- Run [Active IQ Config Advisor](#)
- Check system health using [How\\_to\\_perform\\_a\\_cluster\\_health\\_check\\_with\\_a\\_script\\_in\\_ONTAP](#)

### Step 3: Return the failed part to NetApp

Return the failed part to NetApp, as described in the RMA instructions shipped with the kit. See the [Part Return and Replacements](#) page for further information.

#### Controller

#### Replace the controller module - ASA A900

To replace the impaired controller module, you must shut down the impaired controller, move the internal components to the replacement controller module, install the replacement controller module, and reboot the replacement controller.

#### Before you begin

You must review the prerequisites for the replacement procedure and select the correct one for your version of the ONTAP operating system.

- All drive shelves must be working properly.
- If your system is a FlexArray system or has a V\_StorageAttach license, you must refer to the additional required steps before performing this procedure.
- If your system is in an HA pair, the healthy controller must be able to take over the controller that is being replaced (referred to in this procedure as the “impaired controller”).
- If your system is in a MetroCluster configuration, you must review the section [Choosing the correct recovery procedure](#) to determine whether you should use this procedure.

If this is the procedure you should use, note that the controller replacement procedure for a controller in a four or eight node MetroCluster configuration is the same as that in an HA pair. No MetroCluster-specific steps are required because the failure is restricted to an HA pair and storage failover commands can be used to provide nondisruptive operation during the replacement.

- You must replace the failed component with a replacement FRU component you received from your provider.
- You must be replacing a controller module with a controller module of the same model type. You cannot upgrade your system by just replacing the controller module.
- You cannot change any drives or drive shelves as part of this procedure.
- In this procedure, the boot device is moved from the impaired controller to the replacement controller so that the replacement controller will boot up in the same version of ONTAP as the old controller module.
- It is important that you apply the commands in these steps on the correct systems:
  - The impaired controller is the controller that is being replaced.

- The replacement controller is the new controller that is replacing the impaired controller.
- The healthy controller is the surviving controller.
- You must always capture the controller's console output to a text file.

This provides you a record of the procedure so that you can troubleshoot any issues that you might encounter during the replacement process.

### **Shut down the impaired controller - ASA A900**

Shut down or take over the impaired controller using one of the following options.



## Option 1: Most systems

To shut down the impaired controller, you must determine the status of the controller and, if necessary, take over the controller so that the healthy controller continues to serve data from the impaired controller storage.

### About this task

- If you have a SAN system, you must have checked event messages (`cluster kernel-service show`) for the impaired controller SCSI blade. The `cluster kernel-service show` command (from `priv advanced` mode) displays the node name, quorum status of that node, availability status of that node, and operational status of that node.

Each SCSI-blade process should be in quorum with the other nodes in the cluster. Any issues must be resolved before you proceed with the replacement.

- If you have a cluster with more than two nodes, it must be in quorum. If the cluster is not in quorum or a healthy controller shows false for eligibility and health, you must correct the issue before shutting down the impaired controller; see [Synchronize a node with the cluster](#).

### Steps

1. If AutoSupport is enabled, suppress automatic case creation by invoking an AutoSupport message:  

```
system node autosupport invoke -node * -type all -message MAINT=<# of hours>h
```

The following AutoSupport message suppresses automatic case creation for two hours: `cluster1:>`  

```
system node autosupport invoke -node * -type all -message MAINT=2h
```

2. Disable automatic giveback from the console of the healthy controller: 

```
storage failover modify -node local -auto-giveback false
```



When you see *Do you want to disable auto-giveback?*, enter *y*.

3. Take the impaired controller to the LOADER prompt:

If the impaired controller is displaying...	Then...
The LOADER prompt	Go to the next step.
Waiting for giveback...	Press Ctrl-C, and then respond <i>y</i> when prompted.
System prompt or password prompt	Take over or halt the impaired controller from the healthy controller: <pre>storage failover takeover -ofnode impaired_node_name</pre> When the impaired controller shows <i>Waiting for giveback...</i> , press Ctrl-C, and then respond <i>y</i> .

## Option 2: Controller is in a MetroCluster



Do not use this procedure if your system is in a two-node MetroCluster configuration.

To shut down the impaired controller, you must determine the status of the controller and, if necessary, take over the controller so that the healthy controller continues to serve data from the impaired controller storage.

- If you have a cluster with more than two nodes, it must be in quorum. If the cluster is not in quorum or a healthy controller shows false for eligibility and health, you must correct the issue before shutting down the impaired controller; see [Synchronize a node with the cluster](#).
- If you have a MetroCluster configuration, you must have confirmed that the MetroCluster Configuration State is configured and that the nodes are in an enabled and normal state (`metrocluster node show`).

### Steps

1. If AutoSupport is enabled, suppress automatic case creation by invoking an AutoSupport message:

```
system node autosupport invoke -node * -type all -message
MAINT=number_of_hours_downh
```

The following AutoSupport message suppresses automatic case creation for two hours:

```
cluster1:*> system node autosupport invoke -node * -type all -message
MAINT=2h
```

2. Disable automatic giveback from the console of the healthy controller: `storage failover modify -node local -auto-giveback false`
3. Take the impaired controller to the LOADER prompt:

If the impaired controller is displaying...	Then...
The LOADER prompt	Go to the next step.
Waiting for giveback...	Press Ctrl-C, and then respond <code>y</code> when prompted.
System prompt or password prompt (enter system password)	Take over or halt the impaired controller from the healthy controller: <code>storage failover takeover -ofnode <i>impaired_node_name</i></code>  When the impaired controller shows Waiting for giveback..., press Ctrl-C, and then respond <code>y</code> .

### Replace the controller module hardware - ASA A900

To replace the controller module hardware, you must remove the impaired controller, move FRU components to the replacement controller module, install the replacement controller module in the chassis, and then boot the system to Maintenance mode.

The following animation shows the whole process of moving components from the impaired to the replacement controller.

### **Step 1: Remove the controller module**

To access components inside the controller, you must first remove the controller module from the system and then remove the cover on the controller module.

1. If you are not already grounded, properly ground yourself.
2. Unplug the cables from the impaired controller module, and keep track of where the cables were connected.
3. Slide the terra cotta button on the cam handle downward until it unlocks.

[Animation - Remove the controller](#)

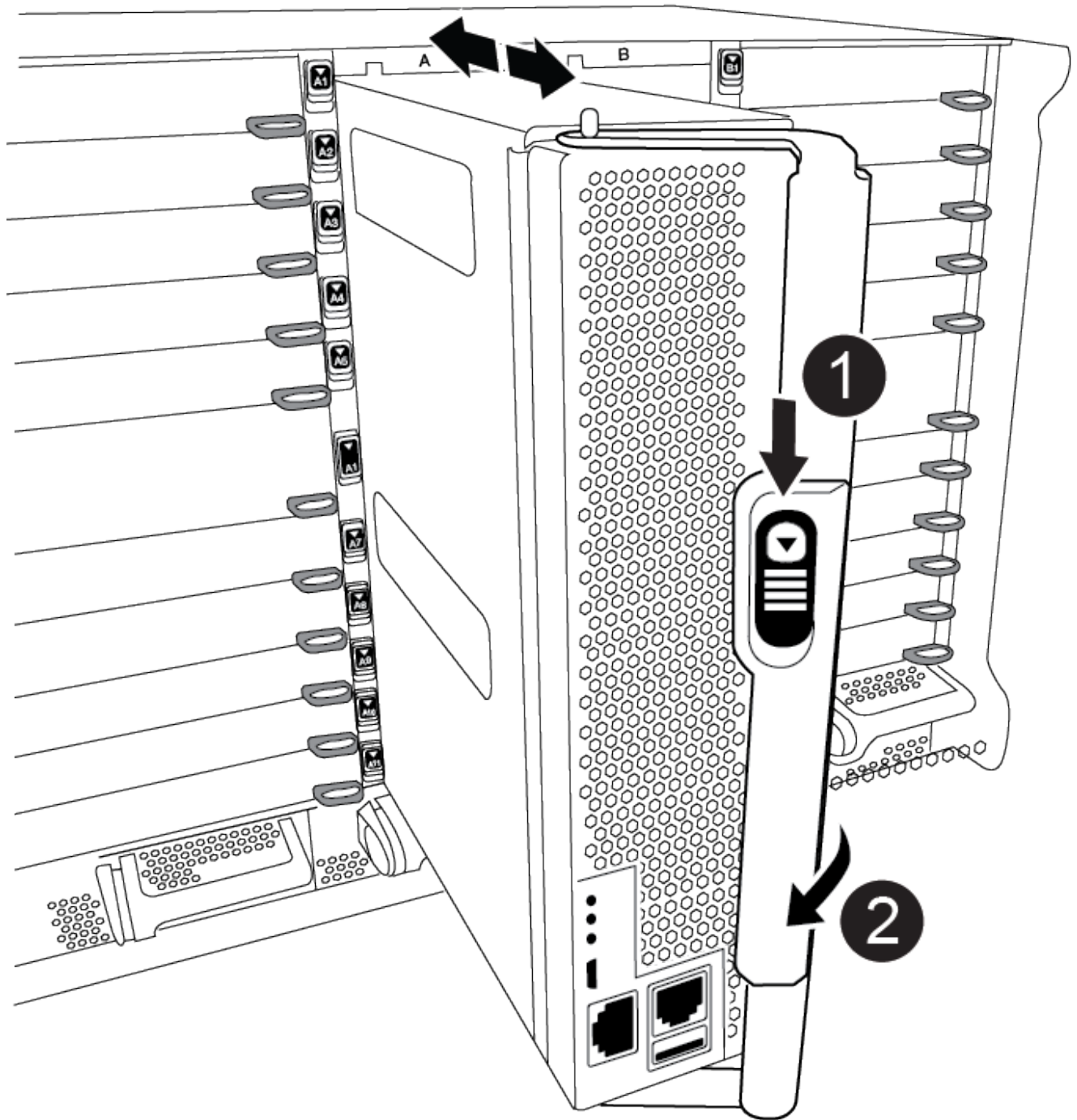

1	Cam handle release button
2	Cam handle

4. Rotate the cam handle so that it completely disengages the controller module from the chassis, and then slide the controller module out of the chassis.

Make sure that you support the bottom of the controller module as you slide it out of the chassis.

5. Place the controller module lid-side up on a stable, flat surface, press the blue button on the cover, slide the cover to the back of the controller module, and then swing the cover up and lift it off of the controller module.

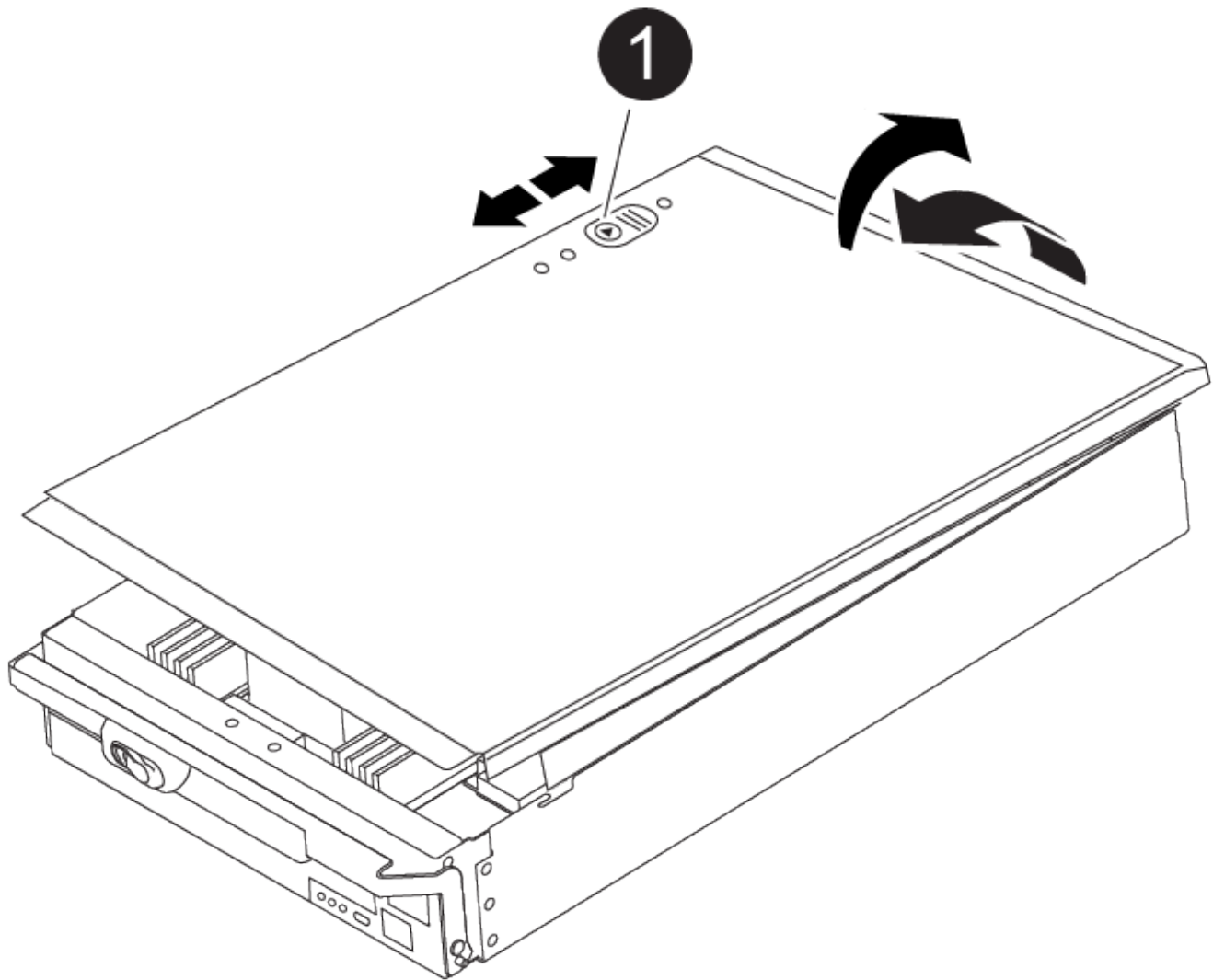

1	Controller module cover locking button
---	--

### Step 2: Move the boot media

You must locate the boot media and follow the directions to remove it from the old controller and insert it in the new controller.

1. Locate the boot media using the following illustration or the FRU map on the controller module:

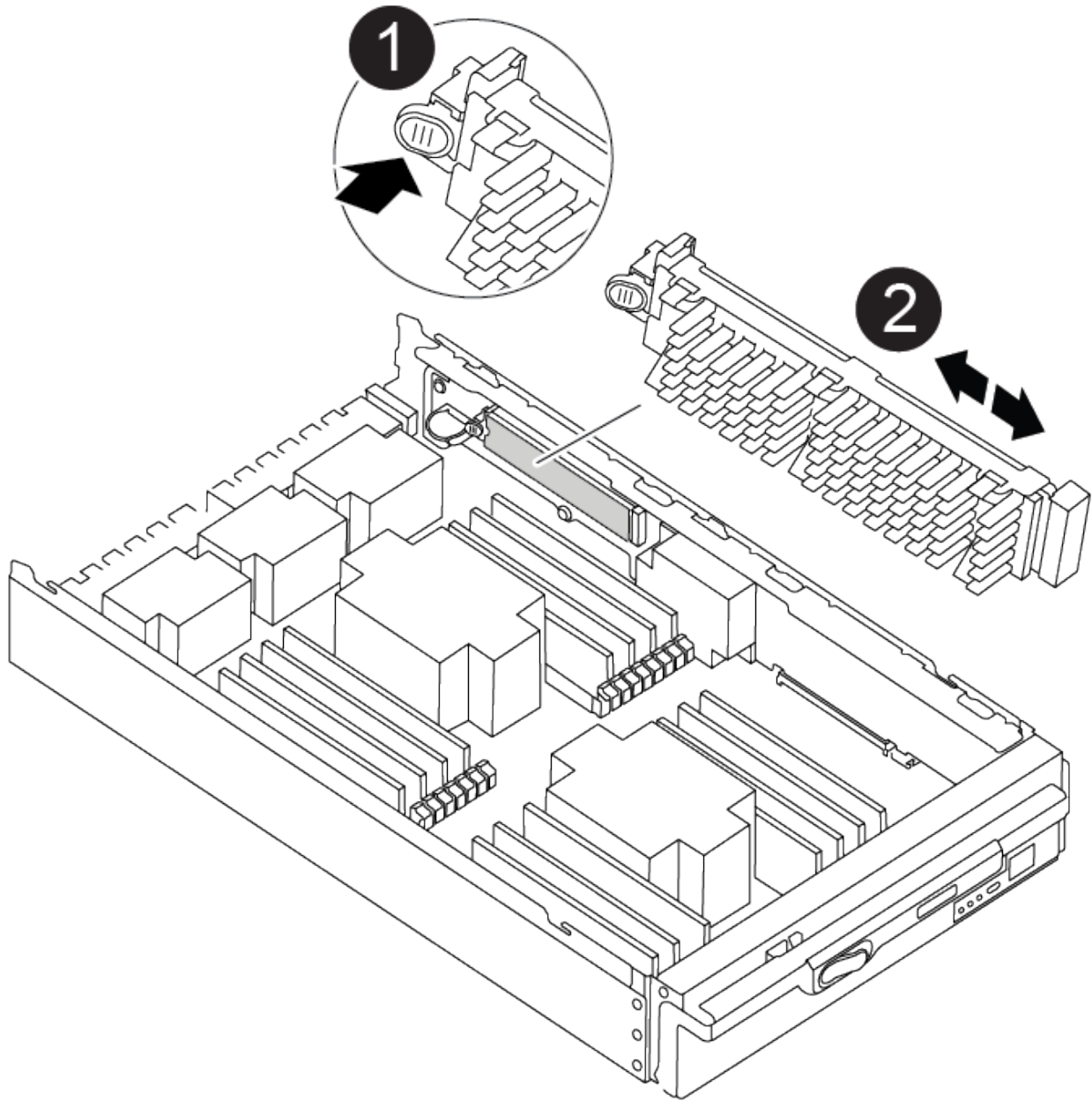

1	Press release tab
2	Boot media

2. Press the blue button on the boot media housing to release the boot media from its housing, and then gently pull it straight out of the boot media socket.



Do not twist or pull the boot media straight up, because this could damage the socket or the boot media.

3. Move the boot media to the new controller module, align the edges of the boot media with the socket housing, and then gently push it into the socket.

4. Check the boot media to make sure that it is seated squarely and completely in the socket.

If necessary, remove the boot media and reseal it into the socket.

5. Push the boot media down to engage the locking button on the boot media housing.

### Step 3: Move the system DIMMs

To move the DIMMs, locate and move them from the old controller into the replacement controller and follow the specific sequence of steps.



The VER2 controller has fewer DIMM sockets. There is no reduction in the number of DIMMs supported or change in the DIMM socket numbering. When moving the DIMMs to the new controller module, install the DIMMs into the same socket number/location as the impaired controller module. See the FRU map diagram on the VER2 controller module for DIMM socket locations.

1. If you are not already grounded, properly ground yourself.
2. Locate the DIMMs on your controller module.
3. Note the orientation of the DIMM in the socket so that you can insert the DIMM in the replacement controller module in the proper orientation.
4. Eject the DIMM from its slot by slowly pushing apart the two DIMM ejector tabs on either side of the DIMM, and then slide the DIMM out of the slot.



Carefully hold the DIMM by the edges to avoid pressure on the components on the DIMM circuit board.

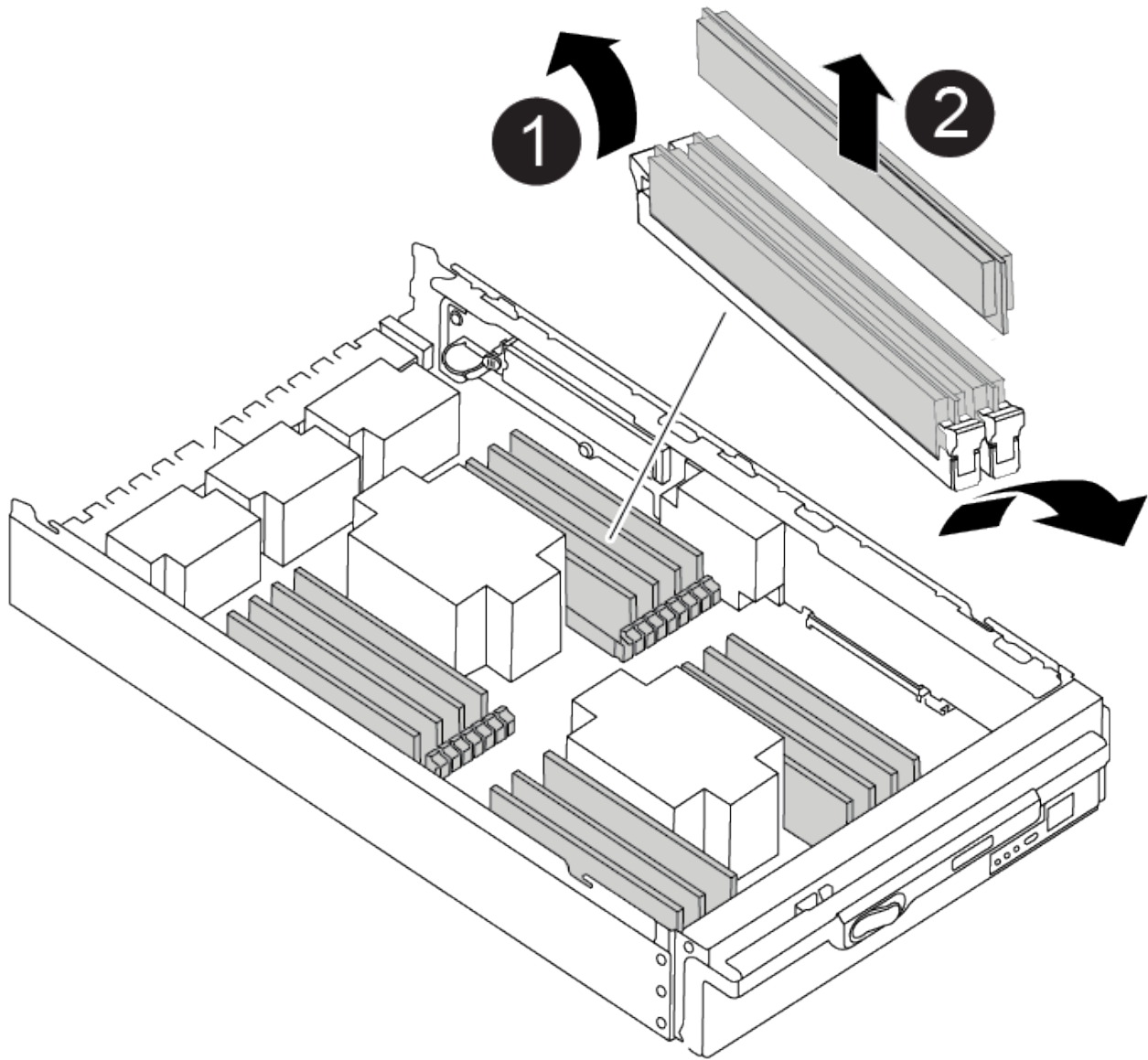

1	DIMM ejector tabs
2	DIMM

5. Locate the slot where you are installing the DIMM.

6. Make sure that the DIMM ejector tabs on the connector are in the open position, and then insert the DIMM squarely into the slot.

The DIMM fits tightly in the slot, but should go in easily. If not, realign the DIMM with the slot and reinsert it.



Visually inspect the DIMM to verify that it is evenly aligned and fully inserted into the slot.

7. Insert the DIMM squarely into the slot.

The DIMM fits tightly in the slot, but should go in easily. If not, realign the DIMM with the slot and reinsert it.





Visually inspect the DIMM to verify that it is evenly aligned and fully inserted into the slot.

8. Push carefully, but firmly, on the top edge of the DIMM until the ejector tabs snap into place over the notches at the ends of the DIMM.
9. Repeat these steps for the remaining DIMMs.

#### Step 4: Install the controller

After you install the components into the replacement controller module, you must install the replacement controller module into the system chassis and boot the operating system.

For HA pairs with two controller modules in the same chassis, the sequence in which you install the controller module is especially important because it attempts to reboot as soon as you completely seat it in the chassis.



The system might update system firmware when it boots. Do not abort this process. The procedure requires you to interrupt the boot process, which you can typically do at any time after prompted to do so. However, if the system updates the system firmware when it boots, you must wait until after the update is complete before interrupting the boot process.

1. If you are not already grounded, properly ground yourself.
2. If you have not already done so, replace the cover on the controller module.
3. Align the end of the controller module with the opening in the chassis, and then gently push the controller module halfway into the system.

[Animation - Install controller](#)

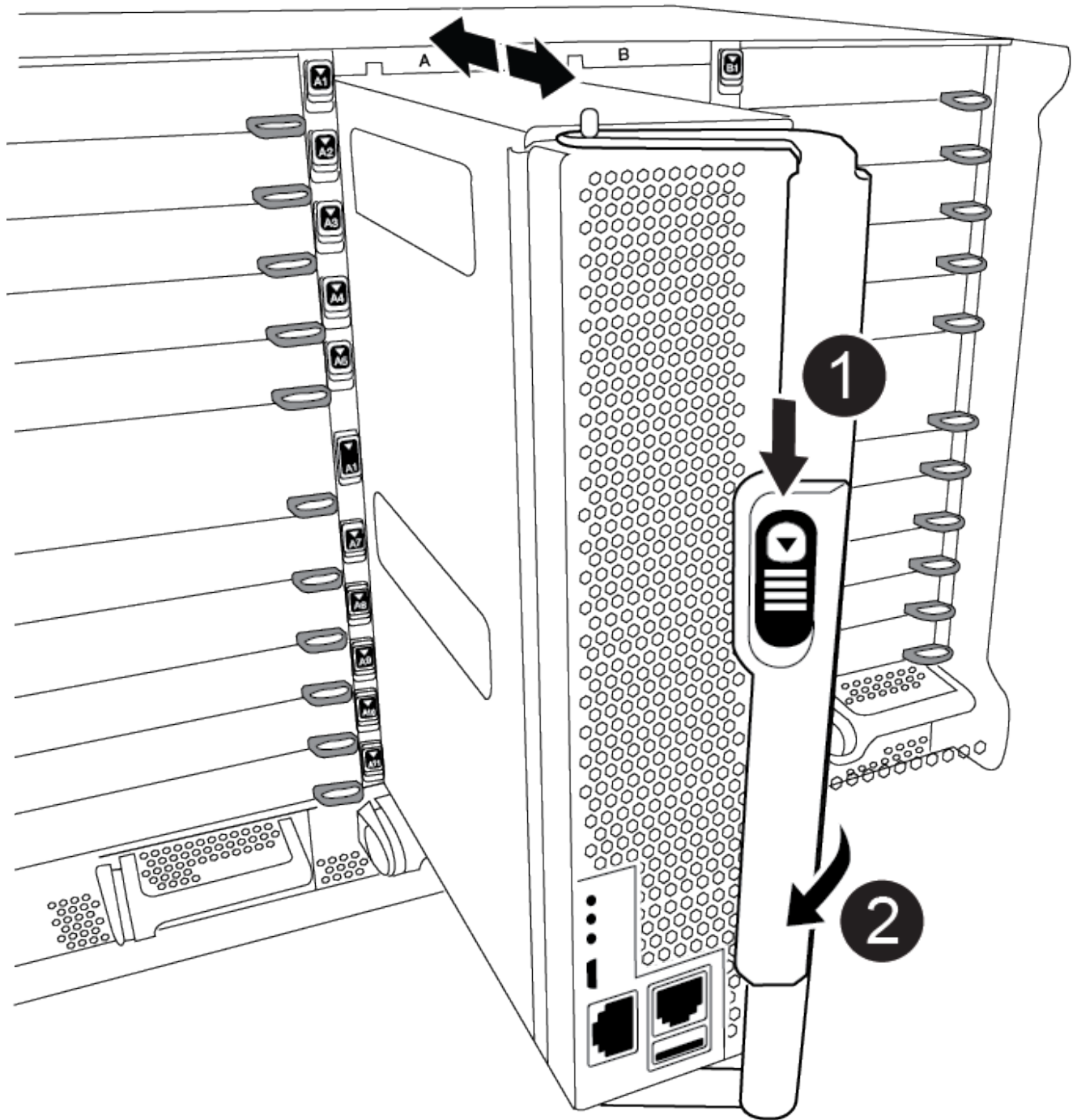

1	Cam handle release button
2	Cam handle



Do not completely insert the controller module in the chassis until instructed to do so.

4. Cable the management and console ports only, so that you can access the system to perform the tasks in

the following sections.



You will connect the rest of the cables to the controller module later in this procedure.

5. Complete the reinstallation of the controller module:

- a. If you have not already done so, reinstall the cable management device.
- b. Firmly push the controller module into the chassis until it meets the midplane and is fully seated.



Do not use excessive force when sliding the controller module into the chassis to avoid damaging the connectors.

The controller module begins to boot as soon as it is fully seated in the chassis. Be prepared to interrupt the boot process.

- c. Rotate the controller module cam handle to the locked position.
- d. Interrupt the boot process by pressing `Ctrl-C` when you see `Press Ctrl-C for Boot Menu`.
- e. Select the option to boot to `LOADER`.

## Restore and verify the system configuration - ASA A900

After completing the hardware replacement, you verify the low-level system configuration of the replacement controller, and reconfigure system settings as necessary.

### Step 1: Set and verify the system time

You should check the time and date on the replacement controller module against the healthy controller module in an HA pair, or against a reliable time server in a stand-alone configuration. If the time and date do not match, you must reset them on the replacement controller module to prevent possible outages on clients due to time differences.

#### About this task

It is important that you apply the commands in the steps on the correct systems:

- The *replacement* node is the new node that replaced the impaired node as part of this procedure.
- The *healthy* node is the HA partner of the *replacement* node.

#### Steps

1. If the *replacement* node is not at the `LOADER` prompt, halt the system to the `LOADER` prompt.
2. On the *healthy* node, check the system time: `cluster date show`

The date and time are based on the configured timezone.

3. At the `LOADER` prompt, check the date and time on the *replacement* node: `show date`

The date and time are given in GMT.

4. If necessary, set the date in GMT on the replacement node: `set date mm/dd/yyyy`
5. If necessary, set the time in GMT on the replacement node: `set time hh:mm:ss`

- At the LOADER prompt, confirm the date and time on the *replacement* node: `show date`

The date and time are given in GMT.

## Step 2: Verify and set the controller's HA state

You must verify the HA state of the controller module and, if necessary, update the state to match your system configuration.

- In Maintenance mode from the replacement controller module, verify that all components display the same HA state: `ha-config show`

If your system is in...	The HA state for all components should be...
An HA pair	ha
A MetroCluster FC configuration with four or more nodes	mcc
A MetroCluster IP configuration	mccip

- If the displayed system state of the controller module does not match your system configuration, set the HA state for the controller module: `ha-config modify controller ha-state`
- If the displayed system state of the chassis does not match your system configuration, set the HA state for the chassis: `ha-config modify chassis ha-state`

## Recable the system - ASA A900

Continue the replacement procedure by recabling the storage and network configurations.

### Step 1: Recable the system

You must recable the controller module's storage and network connections.

#### Steps

- Recable the system.
- Verify that the cabling is correct by using [Active IQ Config Advisor](#).
  - Download and install Config Advisor.
  - Enter the information for the target system, and then click Collect Data.
  - Click the Cabling tab, and then examine the output. Make sure that all disk shelves are displayed and all disks appear in the output, correcting any cabling issues you find.
  - Check other cabling by clicking the appropriate tab, and then examining the output from Config Advisor.



The system ID and disk assignment information reside in the NVRAM module, which is in a module separate from the controller module and not impacted by the controller module replacement.

## Step 2: Reassign disks

If the storage system is in an HA pair, the system ID of the new controller module is automatically assigned to the disks when the giveback occurs at the end of the procedure. You must confirm the system ID change when you boot the *replacement* controller and then verify that the change was implemented.

This procedure applies only to systems running ONTAP in an HA pair.

1. If the *replacement* controller is in Maintenance mode (showing the `*>` prompt), exit Maintenance mode and go to the LOADER prompt: `halt`
2. From the LOADER prompt on the *replacement* controller, boot the controller, entering `y` if you are prompted to override the system ID due to a system ID mismatch: `boot_ontap`
3. Wait until the `Waiting for giveback...` message is displayed on the *replacement* controller console and then, from the healthy controller, verify that the new partner system ID has been automatically assigned: `storage failover show`

In the command output, you should see a message that the system ID has changed on the impaired controller, showing the correct old and new IDs. In the following example, node2 has undergone replacement and has a new system ID of 151759706.

```
node1> `storage failover show`
```

Node	Partner	Takeover Possible	State Description
node1	node2	false	System ID changed on partner (Old: 151759755, New: 151759706), In takeover
node2	node1	-	Waiting for giveback (HA mailboxes)

4. From the healthy controller, verify that any coredumps are saved:
  - a. Change to the advanced privilege level: `set -privilege advanced`

You can respond `y` when prompted to continue into advanced mode. The advanced mode prompt appears (`*>`).
  - b. Save any coredumps: `system node run -node local-node-name partner savecore`
  - c. Wait for the `savecore` command to complete before issuing the giveback.

You can enter the following command to monitor the progress of the `savecore` command: `system node run -node local-node-name partner savecore -s`
  - d. Return to the admin privilege level: `set -privilege admin`
5. If your storage system has Storage or Volume Encryption configured, you must restore Storage or Volume Encryption functionality by using one of the following procedures, depending on whether you are using onboard or external key management:

- [Restore onboard key management encryption keys](#)
- [Restore external key management encryption keys](#)

6. Give back the controller:

- a. From the healthy controller, give back the replaced controller's storage: `storage failover giveback -ofnode replacement_node_name`

The *replacement* controller takes back its storage and completes booting.

If you are prompted to override the system ID due to a system ID mismatch, you should enter *y*.



If the giveback is vetoed, you can consider overriding the vetoes.

For more information, see the [Manual giveback commands](#) topic to override the veto.

- b. After the giveback has been completed, confirm that the HA pair is healthy and that takeover is possible: `storage failover show`

The output from the `storage failover show` command should not include the System ID changed on partner message.

7. Verify that the disks were assigned correctly: `storage disk show -ownership`

The disks belonging to the *replacement* controller should show the new system ID. In the following example, the disks owned by node1 now show the new system ID, 1873775277:

```
node1> `storage disk show -ownership`

Disk  Aggregate Home  Owner  DR Home  Home ID      Owner ID  DR Home ID
Reserver  Pool
-----  -----  -----  -----  -----  -----  -----  -----
-----  ---
1.0.0  aggr0_1  node1  node1  -          1873775277 1873775277  -
1873775277 Pool0
1.0.1  aggr0_1  node1  node1          1873775277 1873775277  -
1873775277 Pool0
.
.
.
```

8. If the system is in a MetroCluster configuration, monitor the status of the controller: `metrocluster node show`

The MetroCluster configuration takes a few minutes after the replacement to return to a normal state, at which time each controller will show a configured state, with DR Mirroring enabled and a mode of normal. The 'metrocluster node show -fields node-systemid' command output displays the old system ID until the MetroCluster configuration returns to a normal state.

9. If the controller is in a MetroCluster configuration, depending on the MetroCluster state, verify that the DR

home ID field shows the original owner of the disk if the original owner is a controller on the disaster site.

This is required if both of the following are true:

- The MetroCluster configuration is in a switchover state.
- The *replacement* controller is the current owner of the disks on the disaster site.

For more information, see [Disk ownership changes during HA takeover and MetroCluster switchover in a four-node MetroCluster configuration](#) topic.

10. If your system is in a MetroCluster configuration, verify that each controller is configured: `metrocluster node show -fields configuration-state`

```
node1_siteA::> metrocluster node show -fields configuration-state

dr-group-id          cluster node          configuration-state
-----
-----
1 node1_siteA        node1mcc-001         configured
1 node1_siteA        node1mcc-002         configured
1 node1_siteB        node1mcc-003         configured
1 node1_siteB        node1mcc-004         configured

4 entries were displayed.
```

11. Verify that the expected volumes are present for each controller: `vol show -node node-name`
12. If you disabled automatic takeover on reboot, enable it from the healthy controller: `storage failover modify -node replacement-node-name -onreboot true`

## Complete system restoration - ASA A900

To complete the replacement procedure and restore your system to full operation, you must recable the storage, restore the NetApp Storage Encryption configuration (if necessary), and install licenses for the new controller. You must complete a series of tasks before restoring your system to full operation.

### Step 1: Install licenses for the new controller

You must install new licenses for the *replacement* node if the impaired node was using ONTAP features that require a standard (node-locked) license. For features with standard licenses, each node in the cluster should have its own key for the feature.

#### About this task

Until you install license keys, features requiring standard licenses continue to be available to the *replacement* node. However, if the impaired node was the only node in the cluster with a license for the feature, no configuration changes to the feature are allowed.

Also, using unlicensed features on the node might put you out of compliance with your license agreement, so you should install the replacement license key or keys on the *replacement* node as soon as possible.

The license keys must be in the 28-character format.

You have a 90-day grace period in which to install the license keys. After the grace period, all old licenses are invalidated. After a valid license key is installed, you have 24 hours to install all of the keys before the grace period ends.

If the node is in a MetroCluster configuration and all nodes at a site have been replaced, license keys must be installed on the *replacement* node or nodes prior to switchback.

### Steps

1. If you need new license keys, obtain replacement license keys on the [NetApp Support site](#) in the My Support section under Software licenses.



The new license keys that you require are automatically generated and sent to the email address on file. If you fail to receive the email with the license keys within 30 days, you should contact technical support.

2. Install each license key: `system license add -license-code license-key, license-key...`
3. Remove the old licenses, if desired:
  - a. Check for unused licenses: `license clean-up -unused -simulate`
  - b. If the list looks correct, remove the unused licenses: `license clean-up -unused`

### Step 2: Verify LIFs and register the serial number

Before returning the *replacement* node to service, you should verify that the LIFs are on their home ports, and register the serial number of the *replacement* node if AutoSupport is enabled, and reset automatic giveback.

### Steps

1. Verify that the logical interfaces are reporting to their home server and ports: `network interface show -is-home false`  
  
If any LIFs are listed as false, revert them to their home ports: `network interface revert -vserver * -lif *`
2. Register the system serial number with NetApp Support.
  - If AutoSupport is enabled, send an AutoSupport message to register the serial number.
  - If AutoSupport is not enabled, call [NetApp Support](#) to register the serial number.
3. If an AutoSupport maintenance window was triggered, end it by using the `system node autosupport invoke -node * -type all -message MAINT=END` command.
4. If automatic giveback was disabled, reenabling it: `storage failover modify -node local -auto-giveback true`

### Step 3: Return the failed part to NetApp

Return the failed part to NetApp, as described in the RMA instructions shipped with the kit. See the [Part Return and Replacements](#) page for further information.



## Replace a DIMM - ASA A900

You must replace a DIMM in the controller module when your system registers an increasing number of correctable error correction codes (ECC); failure to do so causes a system panic.

### **Before you begin**

All other components in the system must be functioning properly; if not, you must contact technical support.

You must replace the failed component with a replacement FRU component you received from your provider.

### **Step 1: Shut down the impaired controller**

Shut down or take over the impaired controller using one of the following options.

## Option 1: Most systems

To shut down the impaired controller, you must determine the status of the controller and, if necessary, take over the controller so that the healthy controller continues to serve data from the impaired controller storage.

### About this task

- If you have a SAN system, you must have checked event messages (`cluster kernel-service show`) for the impaired controller SCSI blade. The `cluster kernel-service show` command (from `priv advanced` mode) displays the node name, quorum status of that node, availability status of that node, and operational status of that node.

Each SCSI-blade process should be in quorum with the other nodes in the cluster. Any issues must be resolved before you proceed with the replacement.

- If you have a cluster with more than two nodes, it must be in quorum. If the cluster is not in quorum or a healthy controller shows false for eligibility and health, you must correct the issue before shutting down the impaired controller; see [Synchronize a node with the cluster](#).

### Steps

1. If AutoSupport is enabled, suppress automatic case creation by invoking an AutoSupport message:

```
system node autosupport invoke -node * -type all -message MAINT=<# of hours>h
```

The following AutoSupport message suppresses automatic case creation for two hours: `cluster1:>`

```
system node autosupport invoke -node * -type all -message MAINT=2h
```

2. Disable automatic giveback from the console of the healthy controller: `storage failover modify -node local -auto-giveback false`



When you see *Do you want to disable auto-giveback?*, enter *y*.

3. Take the impaired controller to the LOADER prompt:

If the impaired controller is displaying...	Then...
The LOADER prompt	Go to the next step.
Waiting for giveback...	Press Ctrl-C, and then respond <i>y</i> when prompted.
System prompt or password prompt	Take over or halt the impaired controller from the healthy controller: <code>storage failover takeover -ofnode <i>impaired_node_name</i></code>  When the impaired controller shows <i>Waiting for giveback...</i> , press Ctrl-C, and then respond <i>y</i> .

## Option 2: Controller is in a MetroCluster



Do not use this procedure if your system is in a two-node MetroCluster configuration.

To shut down the impaired controller, you must determine the status of the controller and, if necessary, take over the controller so that the healthy controller continues to serve data from the impaired controller storage.

- If you have a cluster with more than two nodes, it must be in quorum. If the cluster is not in quorum or a healthy controller shows false for eligibility and health, you must correct the issue before shutting down the impaired controller; see [Synchronize a node with the cluster](#).
- If you have a MetroCluster configuration, you must have confirmed that the MetroCluster Configuration State is configured and that the nodes are in an enabled and normal state (`metrocluster node show`).

### Steps

1. If AutoSupport is enabled, suppress automatic case creation by invoking an AutoSupport message:

```
system node autosupport invoke -node * -type all -message
MAINT=number_of_hours_downh
```

The following AutoSupport message suppresses automatic case creation for two hours:

```
cluster1:*> system node autosupport invoke -node * -type all -message
MAINT=2h
```

2. Disable automatic giveback from the console of the healthy controller: `storage failover modify -node local -auto-giveback false`
3. Take the impaired controller to the LOADER prompt:

If the impaired controller is displaying...	Then...
The LOADER prompt	Go to the next step.
Waiting for giveback...	Press Ctrl-C, and then respond <code>y</code> when prompted.
System prompt or password prompt (enter system password)	Take over or halt the impaired controller from the healthy controller: <code>storage failover takeover -ofnode <i>impaired_node_name</i></code>  When the impaired controller shows Waiting for giveback..., press Ctrl-C, and then respond <code>y</code> .

### Step 2: Remove the controller module

To access components inside the controller, you must first remove the controller module from the system and then remove the cover on the controller module.

1. If you are not already grounded, properly ground yourself.
2. Unplug the cables from the impaired controller module, and keep track of where the cables were connected.

3. Slide the terra cotta button on the cam handle downward until it unlocks.

[Animation - Remove the controller](#)

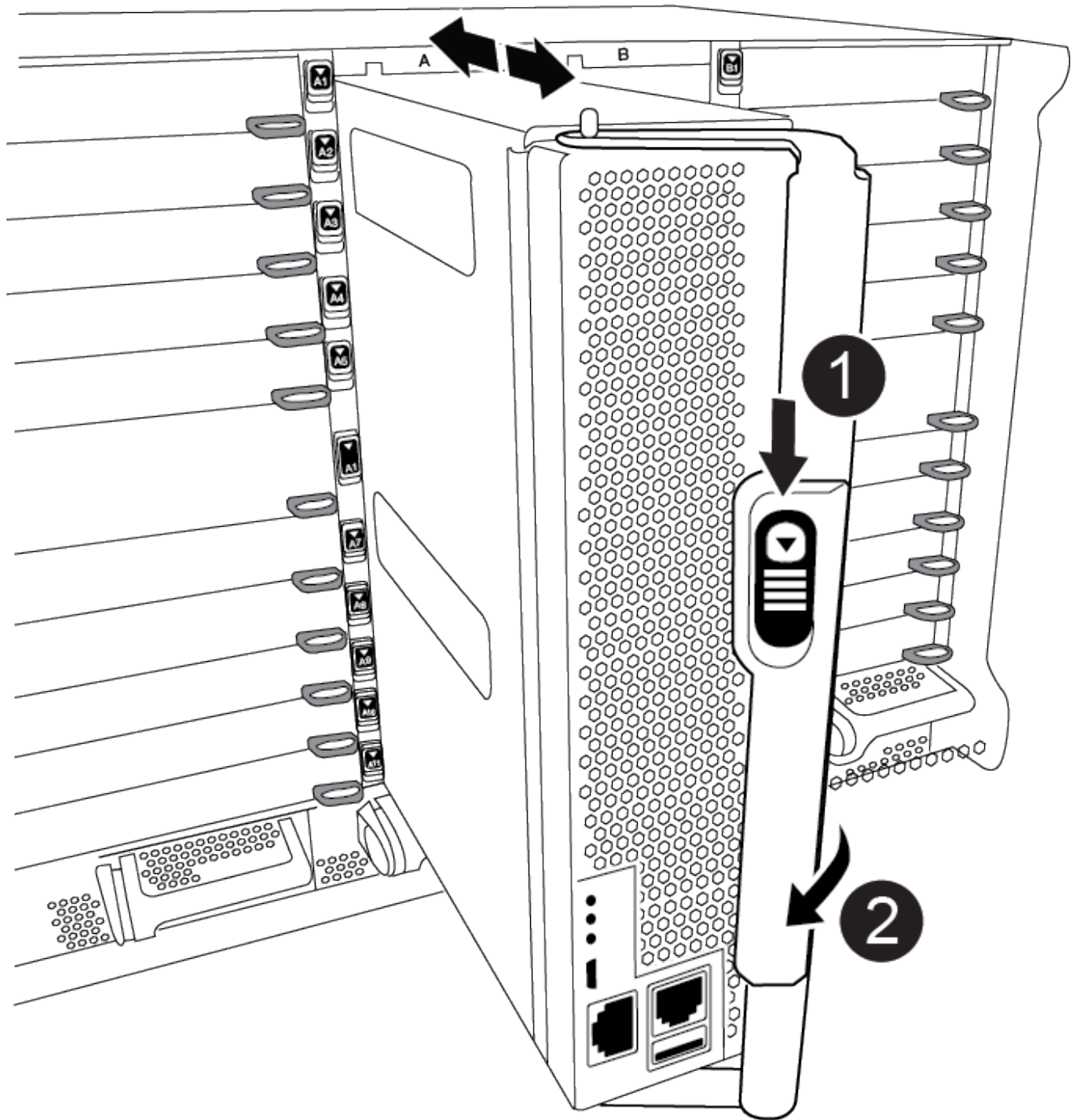

1	Cam handle release button
2	Cam handle

4. Rotate the cam handle so that it completely disengages the controller module from the chassis, and then slide the controller module out of the chassis.

Make sure that you support the bottom of the controller module as you slide it out of the chassis.

5. Place the controller module lid-side up on a stable, flat surface, press the blue button on the cover, slide the cover to the back of the controller module, and then swing the cover up and lift it off of the controller module.

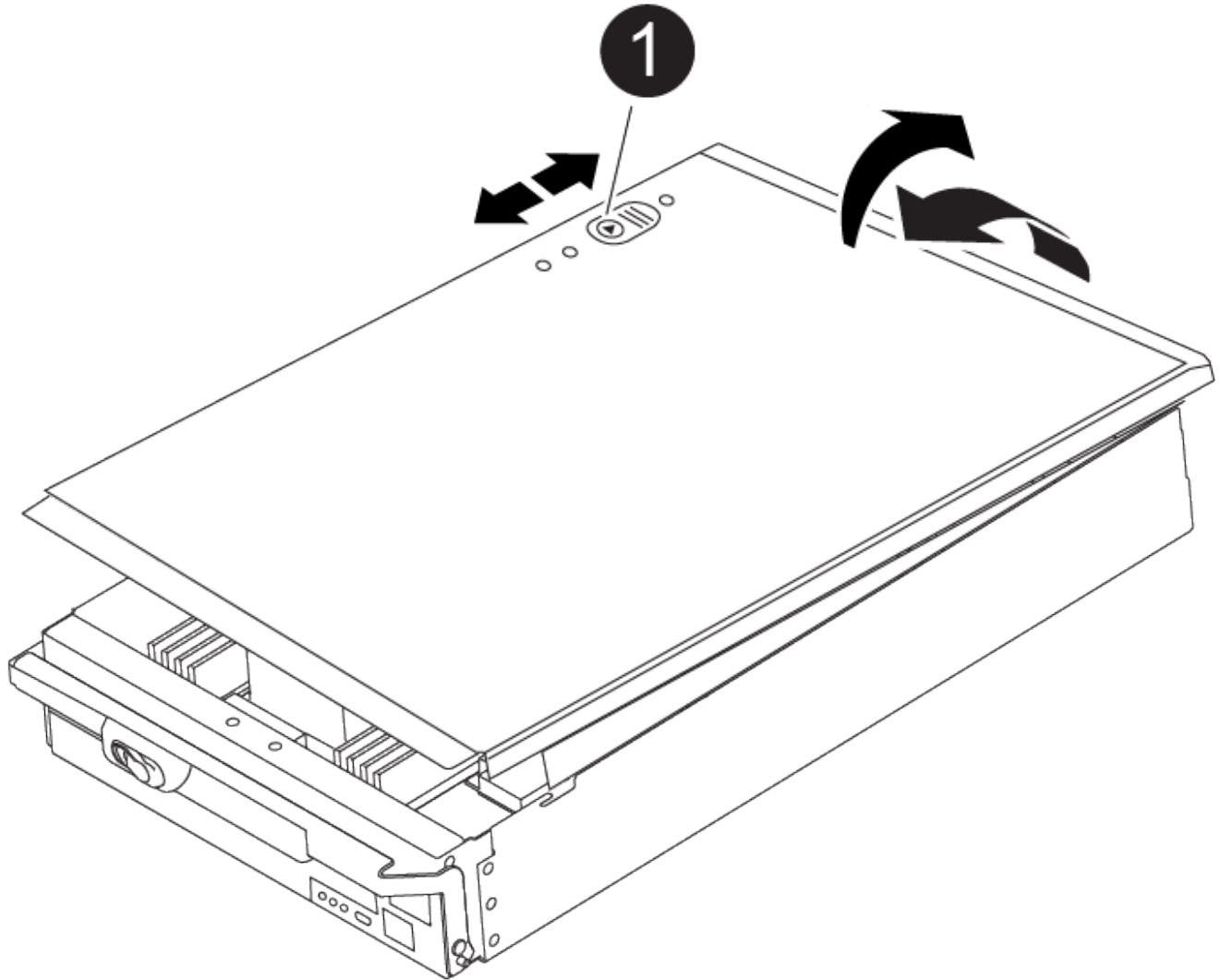

1

Controller module cover locking button

### Step 3: Replace the DIMMs

To replace the DIMMs, locate them inside the controller and follow the specific sequence of steps.



The VER2 controller has fewer DIMM sockets. There is no reduction in the number of DIMMs supported or change in the DIMM socket numbering. When moving the DIMMs to the new controller module, install the DIMMs into the same socket number/location as the impaired controller module. See the FRU map diagram on the VER2 controller module for DIMM socket locations.

1. If you are not already grounded, properly ground yourself.
2. Locate the DIMMs on your controller module.

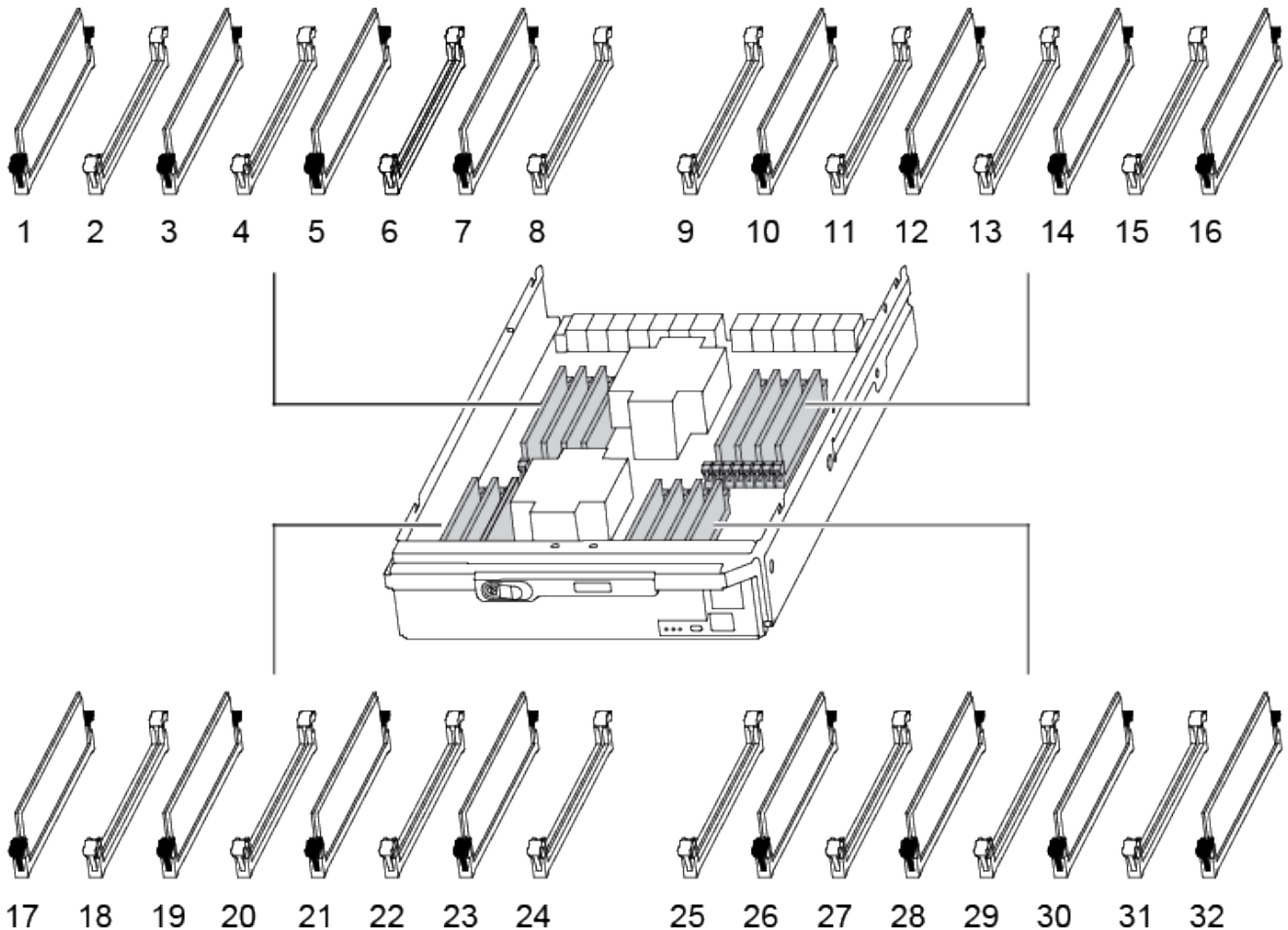

3. Eject the DIMM from its slot by slowly pushing apart the two DIMM ejector tabs on either side of the DIMM, and then slide the DIMM out of the slot.



Carefully hold the DIMM by the edges to avoid pressure on the components on the DIMM circuit board.

[Animation - Replace DIMM](#)

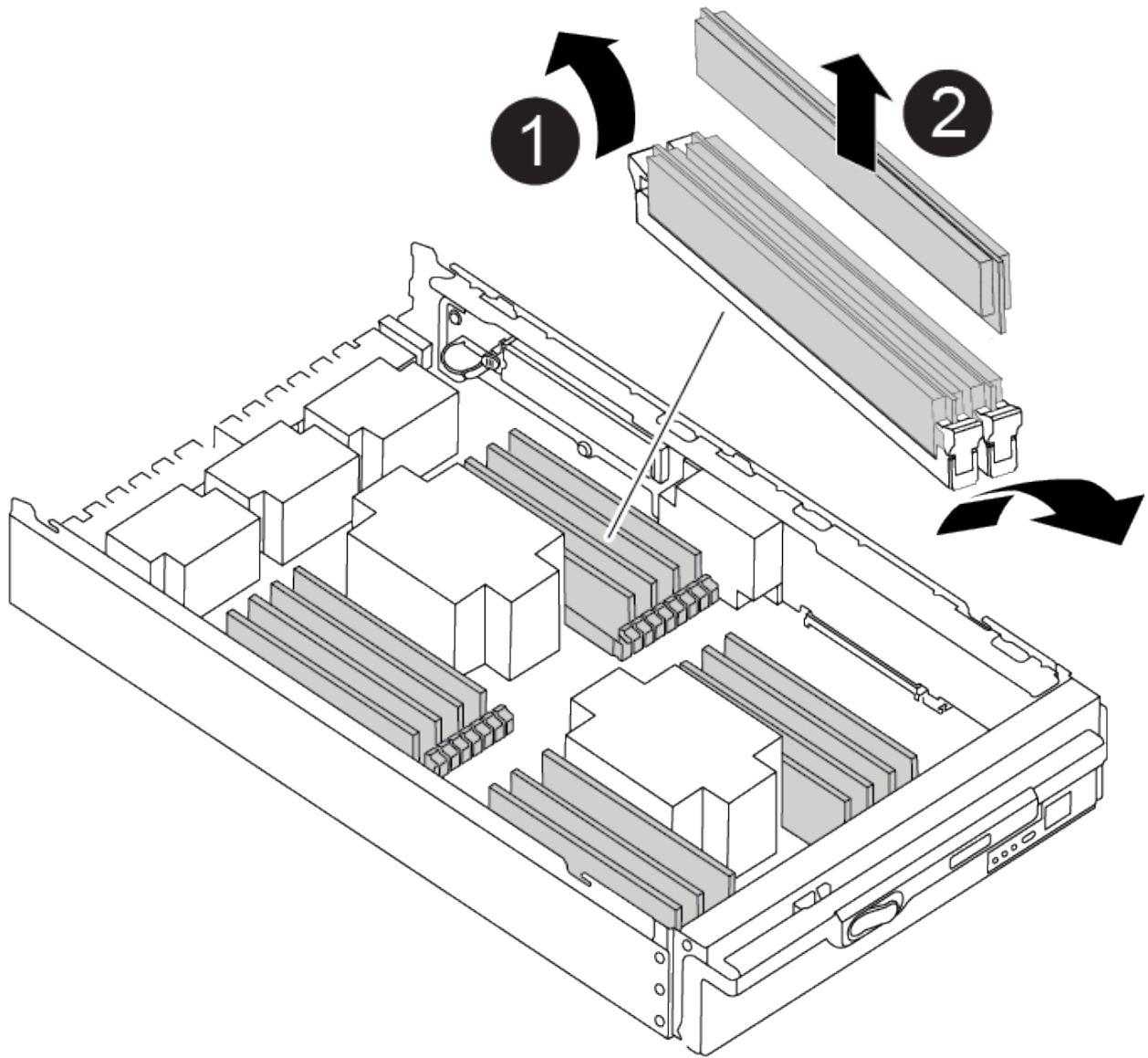

1	DIMM ejector tabs
2	DIMM

4. Remove the replacement DIMM from the antistatic shipping bag, hold the DIMM by the corners, and align it to the slot.

The notch among the pins on the DIMM should line up with the tab in the socket.

5. Make sure that the DIMM ejector tabs on the connector are in the open position, and then insert the DIMM squarely into the slot.

The DIMM fits tightly in the slot, but should go in easily. If not, realign the DIMM with the slot and reinsert it.



Visually inspect the DIMM to verify that it is evenly aligned and fully inserted into the slot.

6. Push carefully, but firmly, on the top edge of the DIMM until the ejector tabs snap into place over the notches at the ends of the DIMM.
7. Close the controller module cover.

#### Step 4: Install the controller

After you install the components into the controller module, you must install the controller module back into the system chassis and boot the operating system.

For HA pairs with two controller modules in the same chassis, the sequence in which you install the controller module is especially important because it attempts to reboot as soon as you completely seat it in the chassis.

1. If you are not already grounded, properly ground yourself.
2. If you have not already done so, replace the cover on the controller module.

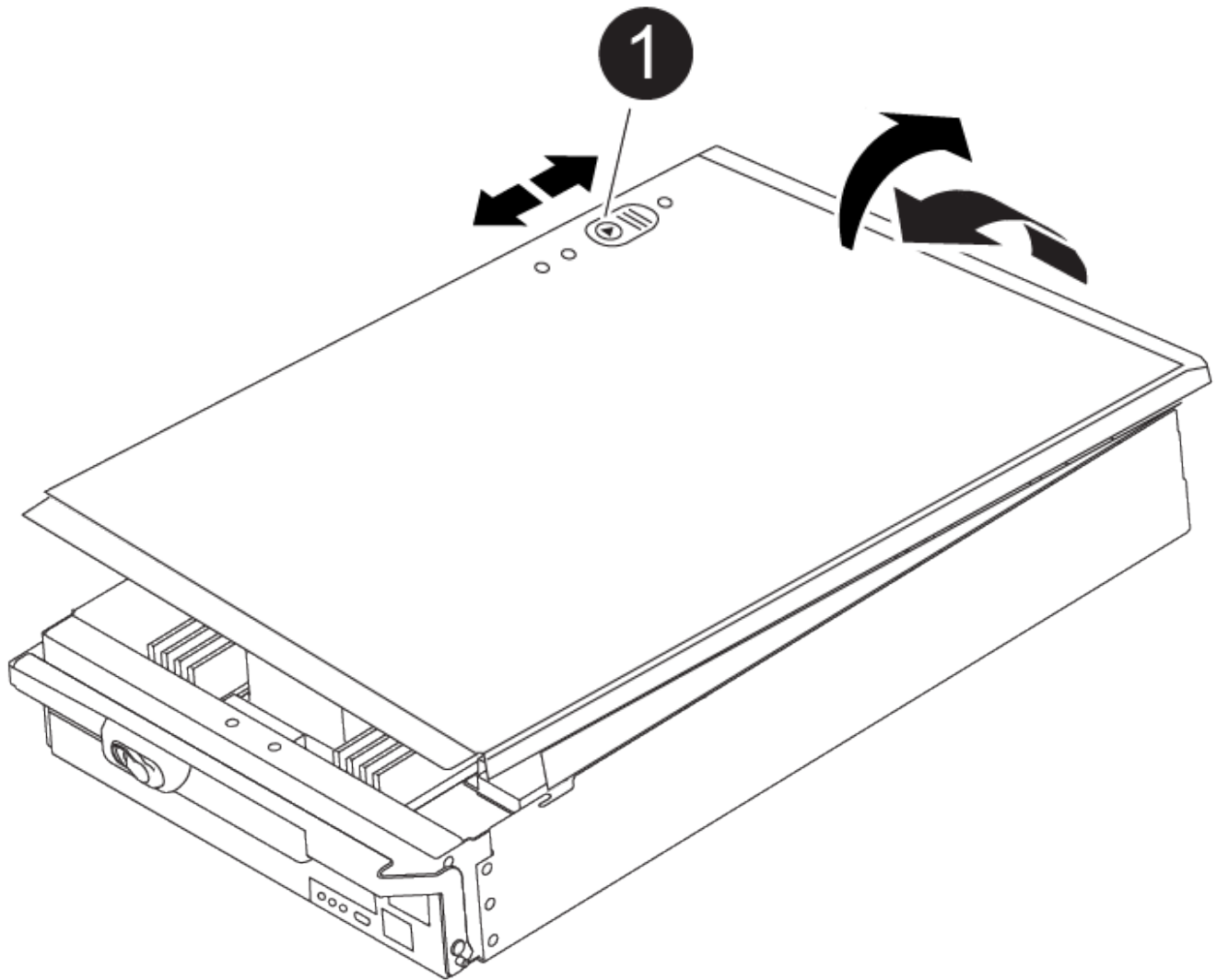

1

Controller module cover locking button

3. Align the end of the controller module with the opening in the chassis, and then gently push the controller module halfway into the system.



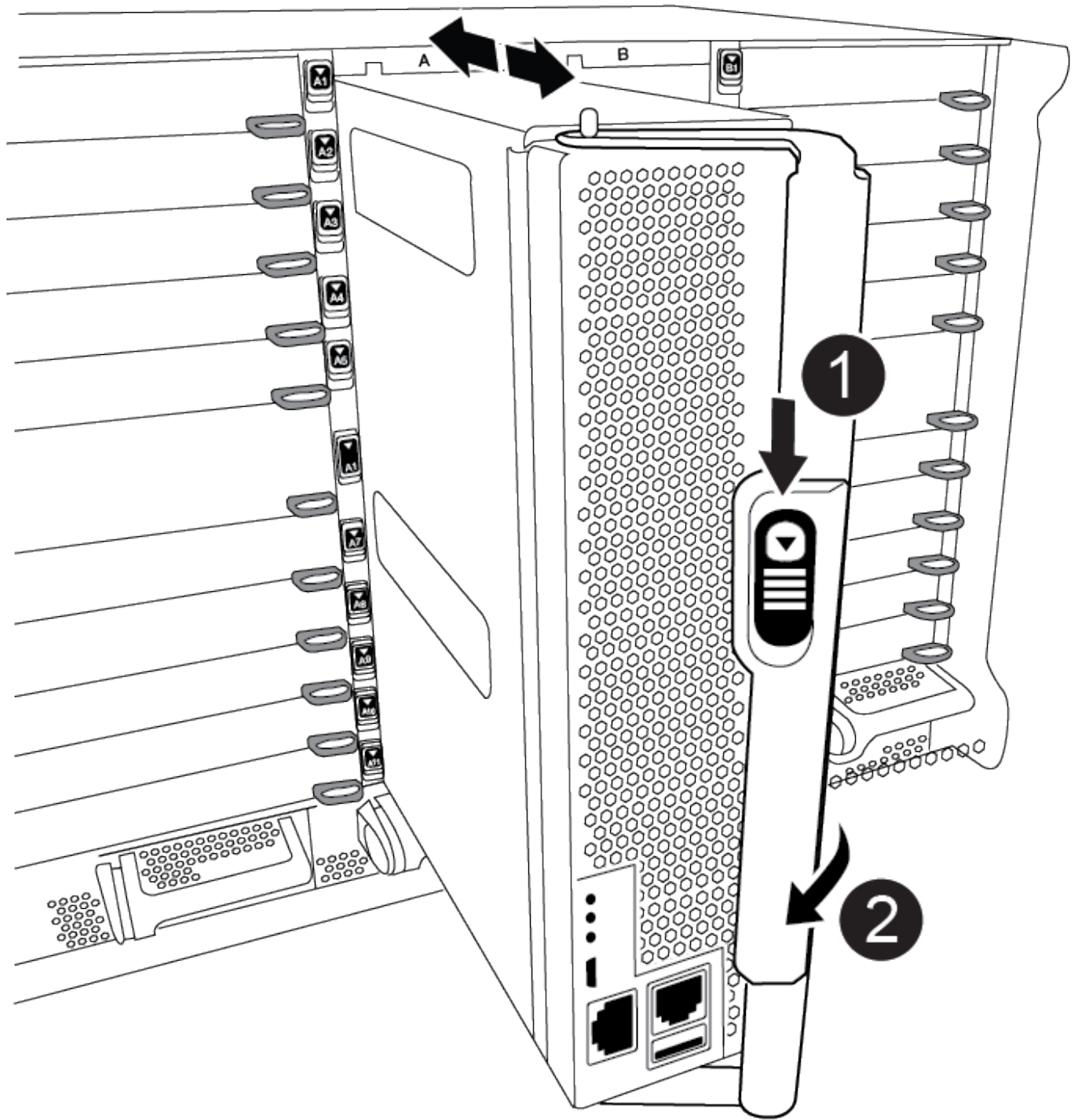

<b>1</b>	Cam handle release button
<b>2</b>	Cam handle



Do not completely insert the controller module in the chassis until instructed to do so.

4. Cable the management and console ports only, so that you can access the system to perform the tasks in the following sections.



You will connect the rest of the cables to the controller module later in this procedure.

5. Complete the reinstallation of the controller module:
  - a. If you have not already done so, reinstall the cable management device.
  - b. Firmly push the controller module into the chassis until it meets the midplane and is fully seated.

The locking latches rise when the controller module is fully seated.



Do not use excessive force when sliding the controller module into the chassis to avoid damaging the connectors.

The controller module begins to boot as soon as it is fully seated in the chassis. Be prepared to interrupt the boot process.

- c. Rotate the locking latches upward, tilting them so that they clear the locking pins, and then lower them into the locked position.
- d. Interrupt the boot process by pressing `Ctrl-C` when you see `Press Ctrl-C for Boot Menu`.
- e. Select the option to boot to Maintenance mode from the displayed menu.

### Step 5: Run system-level diagnostics

After installing a new DIMM, you should run diagnostics.

Your system must be at the `LOADER` prompt to start System Level Diagnostics.

All commands in the diagnostic procedures are issued from the controller where the component is being replaced.

1. If the controller to be serviced is not at the `LOADER` prompt, perform the following steps:
  - a. Select the Maintenance mode option from the displayed menu.
  - b. After the controller boots to Maintenance mode, halt the controller: `halt`

After you issue the command, you should wait until the system stops at the `LOADER` prompt.



During the boot process, you can safely respond `y` to prompts.

- If a prompt appears warning that when entering Maintenance mode in an HA configuration, you must ensure that the healthy controller remains down.

2. At the `LOADER` prompt, access the special drivers specifically designed for system-level diagnostics to function properly: `boot_diags`

During the boot process, you can safely respond `y` to the prompts until the Maintenance mode prompt (`*>`) appears.

3. Run diagnostics on the system memory: `sldiag device run -dev mem`
4. Verify that no hardware problems resulted from the replacement of the DIMMs: `sldiag device status`

-dev mem -long -state failed

System-level diagnostics returns you to the prompt if there are no test failures, or lists the full status of failures resulting from testing the component.

5. Proceed based on the result of the preceding step:

<b>If the system-level diagnostics tests...</b>	<b>Then...</b>
Were completed without any failures	<ul style="list-style-type: none"><li>a. Clear the status logs: <code>sldiag device clearstatus</code></li><li>b. Verify that the log was cleared: <code>sldiag device status</code>  The following default response is displayed:  SLDIAG: No log messages are present.</li><li>c. Exit Maintenance mode: <code>halt</code>  The controller displays the LOADER prompt.</li><li>d. Boot the controller from the LOADER prompt: <code>bye</code></li><li>e. Return the controller to normal operation:</li></ul>
<b>If your controller is in...</b>	<b>Then...</b>
An HA pair	Perform a give back: <code>storage failover giveback -ofnode replacement_node_name</code> <b>Note:</b> If you disabled automatic giveback, re-enable it with the storage failover modify command.

If your controller is in...	Then...
Resulted in some test failures	<p>Determine the cause of the problem:</p> <ol style="list-style-type: none"> <li>a. Exit Maintenance mode: <code>halt</code> <p>After you issue the command, wait until the system stops at the LOADER prompt.</p> </li> <li>b. Verify that you have observed all the considerations identified for running system-level diagnostics, that cables are securely connected, and that hardware components are properly installed in the storage system.</li> <li>c. Boot the controller module you are servicing, interrupting the boot by pressing <code>Ctrl-C</code> when prompted to get to the Boot menu: <ul style="list-style-type: none"> <li>◦ If you have two controller modules in the chassis, fully seat the controller module you are servicing in the chassis. <p>The controller module boots up when fully seated.</p> </li> <li>◦ If you have one controller module in the chassis, connect the power supplies, and then turn them on.</li> </ul> </li> <li>d. Select Boot to maintenance mode from the menu.</li> <li>e. Exit Maintenance mode by entering the following command: <code>halt</code> <p>After you issue the command, wait until the system stops at the LOADER prompt.</p> </li> <li>f. Rerun the system-level diagnostic test.</li> </ol>

## Step 6: Return the failed part to NetApp

Return the failed part to NetApp, as described in the RMA instructions shipped with the kit. See the [Part Return and Replacements](#) page for further information.

### Replace the DCPM containing the NVRAM11 battery - ASA A900

To hot-swap a destage controller power module (DCPM), which contains the NVRAM11 battery, you must locate the failed DCPM module, remove it from the chassis, and install the replacement DCPM module.

You must have a replacement DCPM module in-hand before removing the failed module from the chassis and it must be replaced within five minutes of removal. Once the DCPM module is removed from the chassis, there is no shutdown protection for the controller module that owns the DCPM module, other than failover to the other controller module.

### Step 1: Replace the DCPM module

To replace the DCPM module in your system, you must remove the failed DCPM module from the system and then replace it with a new DCPM module.

1. If you are not already grounded, properly ground yourself.
2. Remove the bezel on the front of the system and set it aside.
3. Locate the failed DCPM module in the front of the system by looking for the Attention LED on the module.

The LED will be steady amber if the module is faulty.



The DCPM module must be replaced in the chassis within five minutes of removal or the associated controller will shut down.

4. Press the terra cotta release button on the module handle, and then slide the DCPM module out of the chassis.

#### Animation - Remove/install DCPM

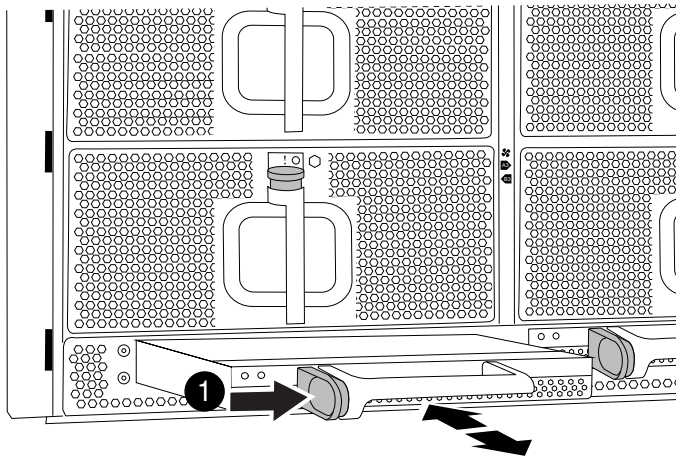

1

DCPM module terra cotta locking button

5. Align the end of the DCPM module with the chassis opening, and then gently slide it into the chassis until it clicks into place.



The module and slot are keyed. Do not force the module into the opening. If the module does not go in easily, realign the module and slide it into the chassis.

The Amber LED flashes four times upon insertion and the green LED also flashes if the battery is providing a voltage. If it does not flash, it will likely need to be replaced.

## Step 2: Dispose of batteries

You must dispose of batteries according to the local regulations regarding battery recycling or disposal. If you cannot properly dispose of batteries, you must return the batteries to NetApp, as described in the RMA instructions that are shipped with the kit.

### Safety Information and Regulatory Notices

### Step 3: Return the failed part to NetApp

Return the failed part to NetApp, as described in the RMA instructions shipped with the kit. See the [Part Return and Replacements](#) page for further information.

#### Swap out a fan - ASA A900

To swap out a fan module without interrupting service, you must perform a specific sequence of tasks.



It is a best practice to replace the power supply within two minutes of removing it from the chassis. The system continues to function, but ONTAP sends messages to the console about the degraded power supply until the power supply is replaced.

#### Steps

1. If you are not already grounded, properly ground yourself.
2. Remove the bezel (if necessary) with two hands, by grasping the openings on each side of the bezel, and then pulling it toward you until the bezel releases from the ball studs on the chassis frame.
3. Identify the fan module that you must replace by checking the console error messages and looking at the Attention LED on each fan module.
4. Press the terra cotta button on the fan module and pull the fan module straight out of the chassis, making sure that you support it with your free hand.



The fan modules are short. Always support the bottom of the fan module with your free hand so that it does not suddenly drop free from the chassis and injure you.

#### Animation - Remove/install fan

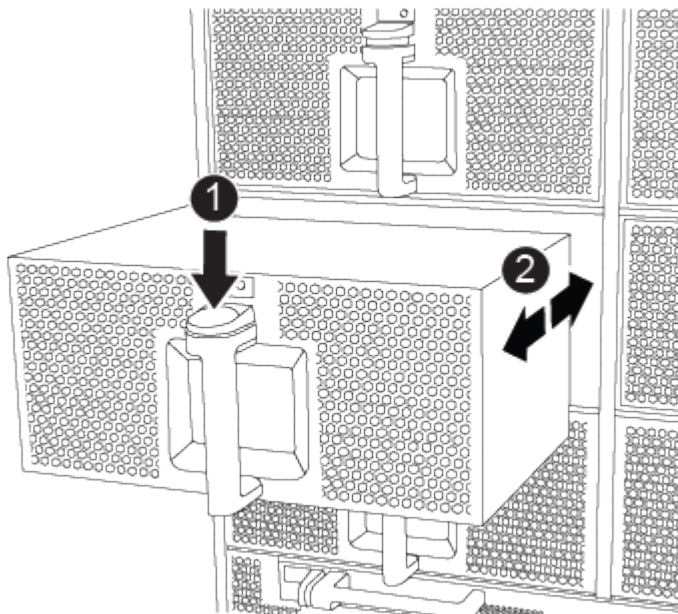

1

Terra cotta release button

2

Slide fan in/out of chassis

5. Set the fan module aside.
6. Align the edges of the replacement fan module with the opening in the chassis, and then slide it into the chassis until it snaps into place.

When inserted into a live system, the amber Attention LED flashes four times when the fan module is successfully inserted into the chassis.

7. Align the bezel with the ball studs, and then gently push the bezel onto the ball studs.
8. Return the failed part to NetApp, as described in the RMA instructions shipped with the kit. See the [Part Return and Replacements](#) page for further information.

## I/O module

### Replace the I/O module - ASA A900

To replace an I/O module, you must perform a specific sequence of tasks.

- You can use this procedure with all versions of ONTAP supported by your system.
- All other components in the system must be functioning properly; if not, you must contact technical support.

#### Step 1: Shut down the impaired node

Shut down or take over the impaired controller using one of the following options.

### Option 1: Most systems

To shut down the impaired controller, you must determine the status of the controller and, if necessary, take over the controller so that the healthy controller continues to serve data from the impaired controller storage.

#### About this task

If you have a cluster with more than two nodes, it must be in quorum. If the cluster is not in quorum or a healthy controller shows false for eligibility and health, you must correct the issue before shutting down the impaired controller; see [Synchronize a node with the cluster](#).

#### Steps

1. If AutoSupport is enabled, suppress automatic case creation by invoking an AutoSupport message command: `system node autosupport invoke -node * -type all -message MAINT=number_of_hours_downh`

The following AutoSupport command suppresses automatic case creation for two hours:

```
cluster1:*> system node autosupport invoke -node * -type all -message MAINT=2h
```

2. Disable automatic giveback from the console of the healthy controller: `storage failover modify -node local -auto-giveback false`
3. Take the impaired controller to the LOADER prompt:

If the impaired controller is displaying...	Then...
The LOADER prompt	Go to the next step.
Waiting for giveback...	Press Ctrl-C, and then respond <i>y</i> when prompted.
System prompt or password prompt (enter system password)	Halt or take over the impaired controller from the healthy controller: <code>storage failover takeover -ofnode <i>impaired_node_name</i></code>  When the impaired controller shows Waiting for giveback..., press Ctrl-C, and then respond <i>y</i> .

### Option 2: Controller is in a MetroCluster



Do not use this procedure if your system is in a two-node MetroCluster configuration.

To shut down the impaired controller, you must determine the status of the controller and, if necessary, take over the controller so that the healthy controller continues to serve data from the impaired controller storage.

- If you have a cluster with more than two nodes, it must be in quorum. If the cluster is not in quorum or a healthy controller shows false for eligibility and health, you must correct the issue before shutting down the impaired controller; see [Synchronize a node with the cluster](#).
- If you have a MetroCluster configuration, you must have confirmed that the MetroCluster



Configuration State is configured and that the nodes are in an enabled and normal state (metrocluster node show).

### Steps

1. If AutoSupport is enabled, suppress automatic case creation by invoking an AutoSupport command:  

```
system node autosupport invoke -node * -type all -message  
MAINT=number_of_hours_downh
```

The following AutoSupport command suppresses automatic case creation for two hours:

```
cluster1:*> system node autosupport invoke -node * -type all -message  
MAINT=2h
```

2. Disable automatic giveback from the console of the healthy controller: 

```
storage failover modify  
-node local -auto-giveback false
```
3. Take the impaired controller to the LOADER prompt:

If the impaired controller is displaying...	Then...
The LOADER prompt	Go to the next Step.
Waiting for giveback...	Press Ctrl-C, and then respond <i>y</i> when prompted.
System prompt or password prompt (enter system password)	Halt or take over the impaired controller from the healthy controller: <pre>storage failover takeover -ofnode impaired_node_name</pre> When the impaired controller shows Waiting for giveback..., press Ctrl-C, and then respond <i>y</i> .

### Step 2: Replace I/O modules

To replace an I/O module, locate it within the chassis and follow the specific sequence of steps.

1. If you are not already grounded, properly ground yourself.
2. Unplug any cabling associated with the target I/O module.

Make sure that you label the cables so that you know where they came from.

3. Remove the target I/O module from the chassis:
  - a. Depress the lettered and numbered cam button.

The cam button moves away from the chassis.

- b. Rotate the cam latch down until it is in a horizontal position.

The I/O module disengages from the chassis and moves about 1/2 inch out of the I/O slot.

- c. Remove the I/O module from the chassis by pulling on the pull tabs on the sides of the module face.

Make sure that you keep track of which slot the I/O module was in.

[Animation - Remove/install I/O module](#)

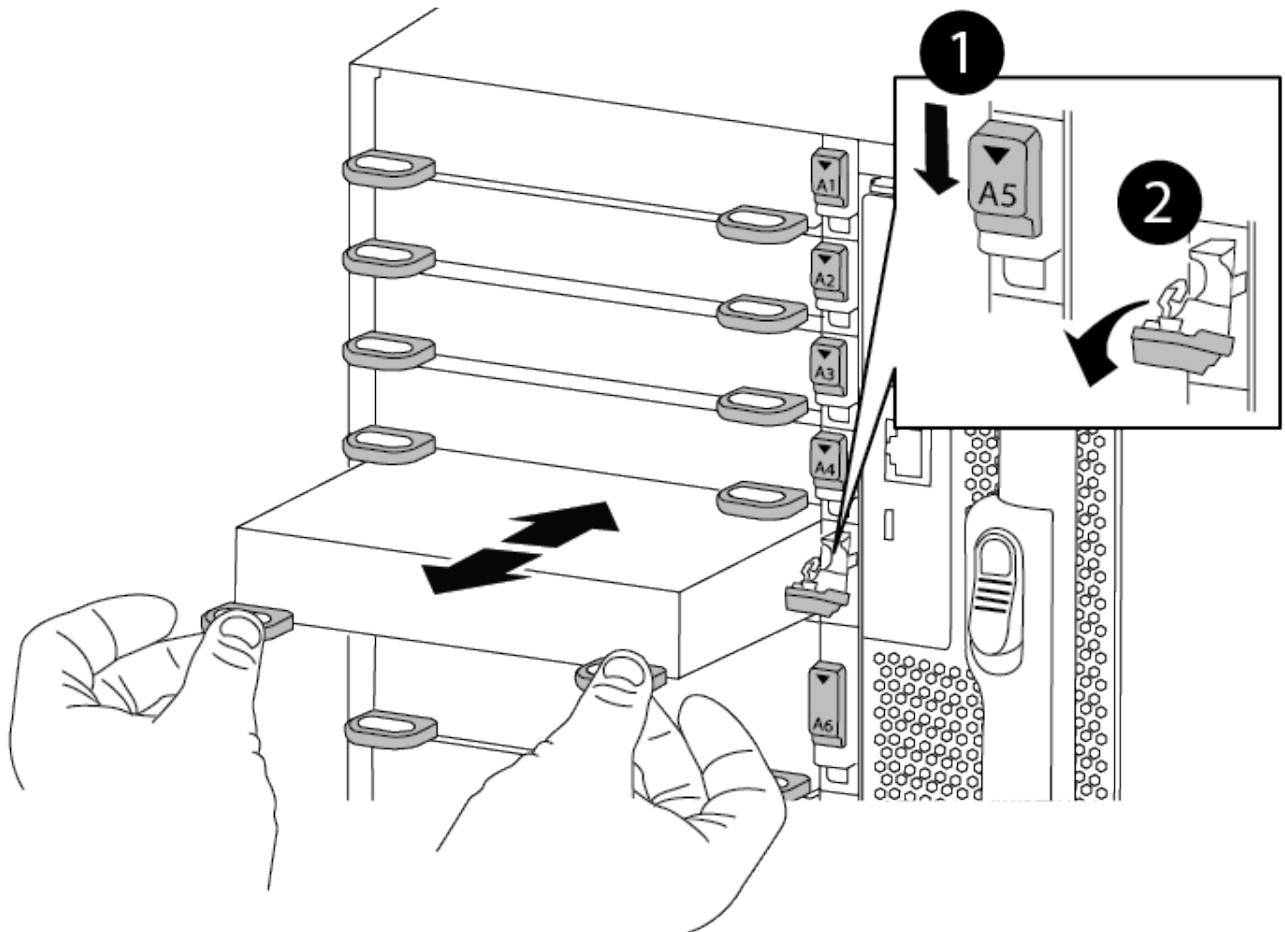

1	Lettered and numbered I/O cam latch
2	I/O cam latch completely unlocked

4. Set the I/O module aside.
5. Install the replacement I/O module into the chassis by gently sliding the I/O module into the slot until the lettered and numbered I/O cam latch begins to engage with the I/O cam pin, and then push the I/O cam latch all the way up to lock the module in place.
6. Recable the I/O module, as needed.

### Step 3: Reboot the controller

After you replace an I/O module, you must reboot the controller module.



If the new I/O module is not the same model as the failed module, you must first reboot the BMC.

## Steps

1. Reboot the BMC if the replacement module is not the same model as the old module:
  - a. From the LOADER prompt, change to advanced privilege mode: `priv set advanced`
  - b. Reboot the BMC: `sp reboot`
2. From the LOADER prompt, reboot the node: `bye`



This reinitializes the PCIe cards and other components and reboots the node.

3. If your system is configured to support 10 GbE cluster interconnect and data connections on 40 GbE NICs, convert these ports to 10 GbE connections by using the `nicadmin convert` command from Maintenance mode. See [Convert 40GbE NIC ports into multiple 10GbE ports for 10GbE connectivity](#) for more information.



Be sure to exit Maintenance mode after completing the conversion.

4. Return the node to normal operation: `storage failover giveback -ofnode impaired_node_name`
5. If automatic giveback was disabled, reenable it: `storage failover modify -node local -auto -giveback true`

## Step 4: Return the failed part to NetApp

Return the failed part to NetApp, as described in the RMA instructions shipped with the kit. See the [Part Return and Replacements](#) page for further information.

### Add an I/O module - ASA A900

You can add an I/O module to your system by either adding a new I/O module into a system with empty slots or by replacing an I/O module with a new one in a fully-populated system.

#### Before you begin

- Check the [NetApp Hardware Universe](#) to make sure that the new I/O module is compatible with your system and version of ONTAP you're running.
- If multiple slots are available, check the slot priorities in [NetApp Hardware Universe](#) and use the best one available for your I/O module.
- To non-disruptively add an I/O module, you must take over the target controller, remove the slot blanking cover in the target slot or remove an existing I/O module, add the new or replacement I/O module, and then giveback the target controller.
- Make sure that all other components are functioning properly.

#### Option 1: Add the I/O module to a system with open slots

You can add an I/O module into an empty module slot in your system.

#### Step 1: Shut down the impaired node

Shut down or take over the impaired controller using one of the following options.

### Option 1: Most systems

To shut down the impaired controller, you must determine the status of the controller and, if necessary, take over the controller so that the healthy controller continues to serve data from the impaired controller storage.

#### About this task

If you have a cluster with more than two nodes, it must be in quorum. If the cluster is not in quorum or a healthy controller shows false for eligibility and health, you must correct the issue before shutting down the impaired controller; see [Synchronize a node with the cluster](#).

#### Steps

1. If AutoSupport is enabled, suppress automatic case creation by invoking an AutoSupport message command: `system node autosupport invoke -node * -type all -message MAINT=number_of_hours_downh`

The following AutoSupport command suppresses automatic case creation for two hours:

```
cluster1:*> system node autosupport invoke -node * -type all -message MAINT=2h
```

2. Disable automatic giveback from the console of the healthy controller: `storage failover modify -node local -auto-giveback false`
3. Take the impaired controller to the LOADER prompt:

If the impaired controller is displaying...	Then...
The LOADER prompt	Go to the next step.
Waiting for giveback...	Press Ctrl-C, and then respond <i>y</i> when prompted.
System prompt or password prompt (enter system password)	Halt or take over the impaired controller from the healthy controller: <code>storage failover takeover -ofnode <i>impaired_node_name</i></code>  When the impaired controller shows Waiting for giveback..., press Ctrl-C, and then respond <i>y</i> .

### Option 2: Controller is in a MetroCluster



Do not use this procedure if your system is in a two-node MetroCluster configuration.

To shut down the impaired controller, you must determine the status of the controller and, if necessary, take over the controller so that the healthy controller continues to serve data from the impaired controller storage.

- If you have a cluster with more than two nodes, it must be in quorum. If the cluster is not in quorum or a healthy controller shows false for eligibility and health, you must correct the issue before shutting down the impaired controller; see [Synchronize a node with the cluster](#).
- If you have a MetroCluster configuration, you must have confirmed that the MetroCluster

Configuration State is configured and that the nodes are in an enabled and normal state (metrocluster node show).

### Steps

1. If AutoSupport is enabled, suppress automatic case creation by invoking an AutoSupport command:  

```
system node autosupport invoke -node * -type all -message  
MAINT=number_of_hours_downh
```

The following AutoSupport command suppresses automatic case creation for two hours:

```
cluster1:*> system node autosupport invoke -node * -type all -message  
MAINT=2h
```

2. Disable automatic giveback from the console of the healthy controller: 

```
storage failover modify  
-node local -auto-giveback false
```
3. Take the impaired controller to the LOADER prompt:

If the impaired controller is displaying...	Then...
The LOADER prompt	Go to the next Step.
Waiting for giveback...	Press Ctrl-C, and then respond <i>y</i> when prompted.
System prompt or password prompt (enter system password)	Halt or take over the impaired controller from the healthy controller: <pre>storage failover takeover -ofnode impaired_node_name</pre> When the impaired controller shows Waiting for giveback..., press Ctrl-C, and then respond <i>y</i> .

### Step 2: Add I/O modules

1. If you are not already grounded, properly ground yourself.
2. Remove the target slot blanking cover:
  - a. Depress the lettered and numbered cam latch.
  - b. Rotate the cam latch down until it is the open position.
  - c. Remove the blanking cover.
3. Install the I/O module:
  - a. Align the I/O module with the edges of the slot.
  - b. Slide the I/O module into the slot until the lettered and numbered I/O cam latch begins to engage with the I/O cam pin.
  - c. Push the I/O cam latch all the way up to lock the module in place.
4. If the replacement I/O module is a NIC, cable the module to the data switches.



Make sure that any unused I/O slots have blanks installed to prevent possible thermal issues.

5. Reboot the controller from the LOADER prompt: `bye`



This reinitializes the PCIe cards and other components and reboots the node.

6. Give back the controller from the partner controller. `storage failover giveback -ofnode target_node_name`

7. Enable automatic giveback if it was disabled: `storage failover modify -node local -auto -giveback true`

8. If you are using slots 3 and/or 7 for networking, use the `storage port modify -node <node name> -port <port name> -mode network` command to convert the slot for networking use.

9. Repeat these steps for controller B.

10. If you installed a storage I/O module, install and cable your NS224 shelves, as described in [Hot-add workflow](#).

## Option 2: Add an I/O module in a system with no open slots

If your system is fully populated, you can change an I/O module in an I/O slot by removing an existing I/O module and replacing it with a different I/O module.

1. If you are:

Replacing a...	Then...
NIC I/O module with the same the same number of ports	The LIFs will automatically migrate when its controller module is shut down.
NIC I/O module with fewer ports	Permanently reassign the affected LIFs to a different home port. See <a href="#">Migrating a LIF</a> for information about using System Manager to permanently move the LIFs.
NIC I/O module with a storage I/O module	Use System Manager to permanently migrate the LIFs to different home ports, as described in <a href="#">Migrating a LIF</a> .

## Step 1: Shut down the impaired node

Shut down or take over the impaired controller using one of the following options.

### Option 1: Most systems

To shut down the impaired controller, you must determine the status of the controller and, if necessary, take over the controller so that the healthy controller continues to serve data from the impaired controller storage.

#### About this task

If you have a cluster with more than two nodes, it must be in quorum. If the cluster is not in quorum or a healthy controller shows false for eligibility and health, you must correct the issue before shutting down the impaired controller; see [Synchronize a node with the cluster](#).

#### Steps

1. If AutoSupport is enabled, suppress automatic case creation by invoking an AutoSupport message command:  

```
system node autosupport invoke -node * -type all -message MAINT=number_of_hours_downh
```

The following AutoSupport command suppresses automatic case creation for two hours:

```
cluster1:*> system node autosupport invoke -node * -type all -message MAINT=2h
```

2. Disable automatic giveback from the console of the healthy controller:  

```
storage failover modify -node local -auto-giveback false
```
3. Take the impaired controller to the LOADER prompt:

If the impaired controller is displaying...	Then...
The LOADER prompt	Go to the next step.
Waiting for giveback...	Press Ctrl-C, and then respond <i>y</i> when prompted.
System prompt or password prompt (enter system password)	Halt or take over the impaired controller from the healthy controller: <pre>storage failover takeover -ofnode <i>impaired_node_name</i></pre> When the impaired controller shows Waiting for giveback..., press Ctrl-C, and then respond <i>y</i> .

### Option 2: Controller is in a MetroCluster



Do not use this procedure if your system is in a two-node MetroCluster configuration.

To shut down the impaired controller, you must determine the status of the controller and, if necessary, take over the controller so that the healthy controller continues to serve data from the impaired controller storage.

- If you have a cluster with more than two nodes, it must be in quorum. If the cluster is not in quorum or a healthy controller shows false for eligibility and health, you must correct the issue before shutting down the impaired controller; see [Synchronize a node with the cluster](#).
- If you have a MetroCluster configuration, you must have confirmed that the MetroCluster

Configuration State is configured and that the nodes are in an enabled and normal state (metrocluster node show).

### Steps

1. If AutoSupport is enabled, suppress automatic case creation by invoking an AutoSupport command:  

```
system node autosupport invoke -node * -type all -message  
MAINT=number_of_hours_downh
```

The following AutoSupport command suppresses automatic case creation for two hours:

```
cluster1:*> system node autosupport invoke -node * -type all -message  
MAINT=2h
```

2. Disable automatic giveback from the console of the healthy controller: 

```
storage failover modify  
-node local -auto-giveback false
```
3. Take the impaired controller to the LOADER prompt:

If the impaired controller is displaying...	Then...
The LOADER prompt	Go to the next Step.
Waiting for giveback...	Press Ctrl-C, and then respond <i>y</i> when prompted.
System prompt or password prompt (enter system password)	Halt or take over the impaired controller from the healthy controller: <pre>storage failover takeover -ofnode impaired_node_name</pre> When the impaired controller shows Waiting for giveback..., press Ctrl-C, and then respond <i>y</i> .

### Step 2: Replace I/O modules

1. If you are not already grounded, properly ground yourself.
2. Unplug any cabling on the target I/O module.
3. Remove the target I/O module from the chassis:

- a. Depress the lettered and numbered cam latch.

The cam latch moves away from the chassis.

- b. Rotate the cam latch down until it is in a horizontal position.

The I/O module disengages from the chassis and moves about 1/2 inch out of the I/O slot.

- c. Remove the I/O module from the chassis by pulling on the pull tabs on the sides of the module face.

Make sure that you keep track of which slot the I/O module was in.

[Animation - Remove or replacing an I/O module](#)



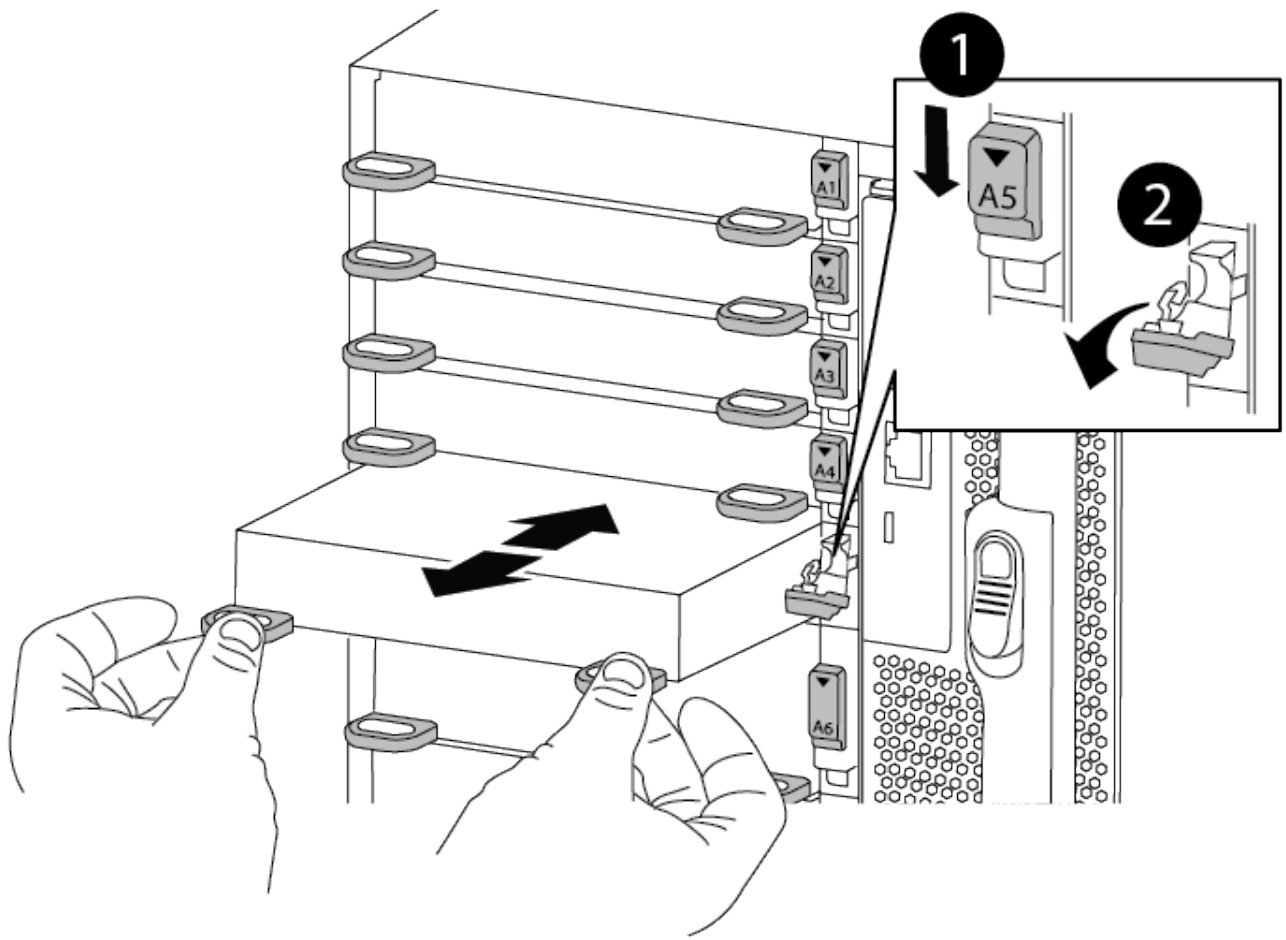

1	Lettered and numbered I/O cam latch
2	I/O cam latch completely unlocked

4. Install the I/O module into the target slot:
  - a. Align the I/O module with the edges of the slot.
  - b. Slide the I/O module into the slot until the lettered and numbered I/O cam latch begins to engage with the I/O cam pin.
  - c. Push the I/O cam latch all the way up to lock the module in place.
5. Repeat the remove and install steps to replace additional modules for controller A.
6. If the replacement I/O module is a NIC, cable the module or modules to the data switches.
7. Reboot the controller from the LOADER prompt:
  - a. Check the version of BMC on the controller: `system service-processor show`
  - b. Update the BMC firmware if needed: `system service-processor image update`
  - c. Reboot the node: `bye`



This reinitializes the PCIe cards and other components and reboots the node.



If you encounter an issue during reboot, see [BURT 1494308 - Environment shutdown might be triggered during I/O module replacement](#)

8. Give back the controller from the partner controller. `storage failover giveback -ofnode target_node_name`
9. Enable automatic giveback if it was disabled: `storage failover modify -node local -auto -giveback true`
10. If you added:

If I/O module is a...	Then...
NIC module in slots 3 or 7,	Use the <code>storage port modify -node *<i>&lt;node name&gt;</i> -port *<i>&lt;port name&gt;</i> -mode network</code> command for each port.
Storage module	Install and cable your NS224 shelves, as described in <a href="#">Hot-add workflow</a> .

11. Repeat these steps for controller B.

#### Replace an LED USB module - ASA A900

The LED USB module provides connectivity to console ports and system status. Replacement of this module does not require tools and does not interrupt service.

#### Step 1: Replace the LED USB module

##### Steps

1. Remove the impaired LED USB module:

[Animation - Remove/install LED-USB module](#)

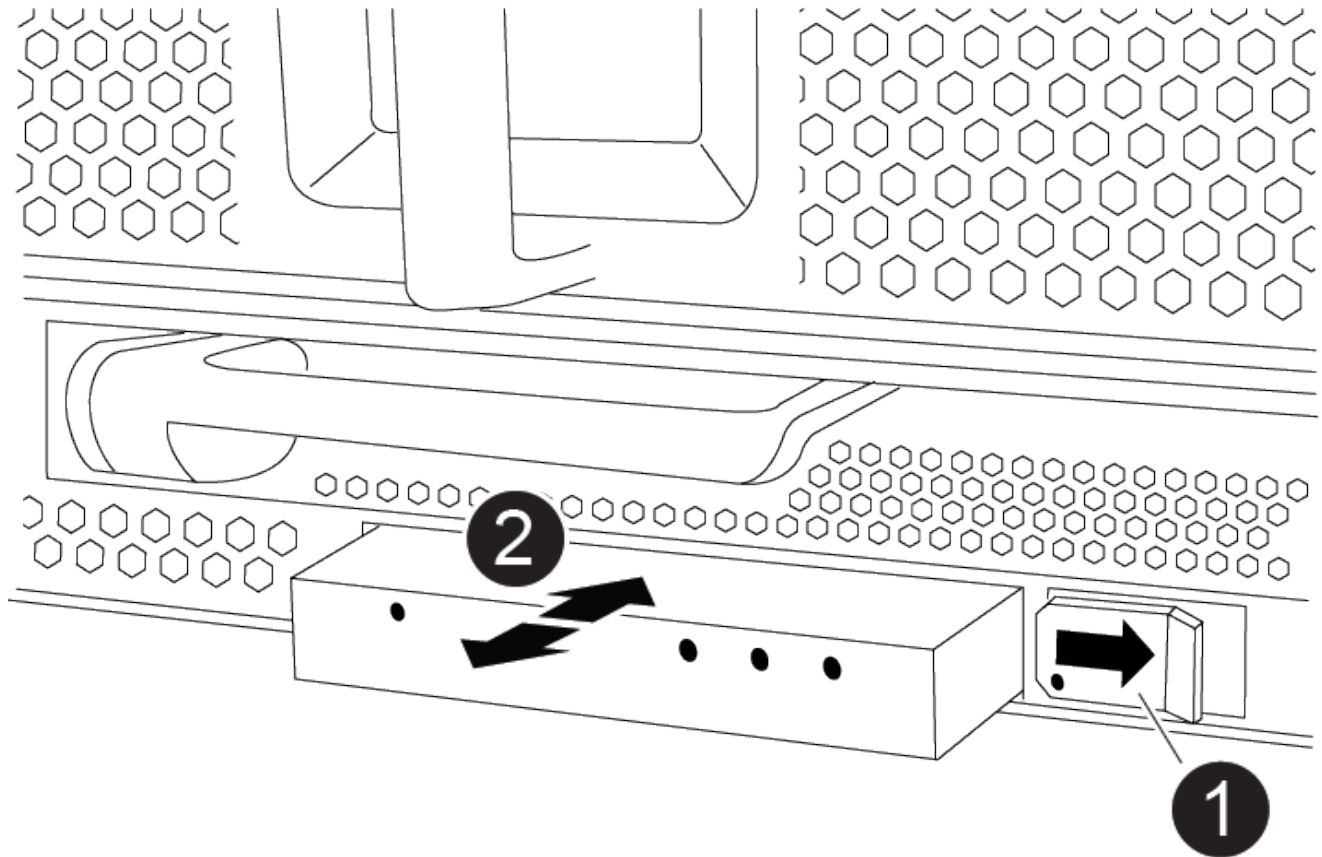

1	Locking button
2	USB LED module

- a. With the bezel removed, locate the LED USB module at the front of the chassis, on the bottom left side.
  - b. Slide the latch to partially eject the module.
  - c. Pull the module out of the bay to disconnect it from the midplane. Do not leave the slot empty.
2. Install the new LED USB module:
- a. Align the module to the bay with the notch in the corner of the module positioned near the slider latch on the chassis. The bay will prevent you from installing the module upside down.
  - b. Push the module into the bay until it is fully seated flush with the chassis.

There is an audible click when the module is secure and connected to the midplane.

## Step 2: Return the failed component

1. Return the failed part to NetApp, as described in the RMA instructions shipped with the kit. See the [Part Return and Replacements](#) page for further information.

## Replace the NVRAM module and NVRAM DIMMs - ASA A900

The NVRAM module consists of the NVRAM11 and DIMMs. You can replace a failed

NVRAM module or the DIMMs inside the NVRAM module. To replace a failed NVRAM module, you must remove it from the chassis, move the DIMMs to the replacement module, and install the replacement NVRAM module into the chassis.

To replace and NVRAM DIMM, you must remove the NVRAM module from the chassis, replace the failed DIMM in the module, and then reinstall the NVRAM module.

### **About this task**

Because the system ID is derived from the NVRAM module, if replacing the module, disks belonging to the system are reassigned to a new system ID.

### **Before you begin**

- All disk shelves must be working properly.
- If your system is in an HA pair, the partner controller must be able to take over the controller associated with the NVRAM module that is being replaced.
- This procedure uses the following terminology:
  - The impaired controller is the controller on which you are performing maintenance.
  - The healthy controller is the HA partner of the impaired controller.
- This procedure includes steps for automatically reassigning disks to the controller module associated with the new NVRAM module. You must reassign the disks when directed to in the procedure. Completing the disk reassignment before giveback can cause issues.
- You must replace the failed component with a replacement FRU component you received from your provider.
- You cannot change any disks or disk shelves as part of this procedure.

### **Step 1: Shut down the impaired controller**

Shut down or take over the impaired controller using one of the following options.

## Option 1: Most systems

To shut down the impaired controller, you must determine the status of the controller and, if necessary, take over the controller so that the healthy controller continues to serve data from the impaired controller storage.

### About this task

- If you have a SAN system, you must have checked event messages (`cluster kernel-service show`) for the impaired controller SCSI blade. The `cluster kernel-service show` command (from `priv advanced` mode) displays the node name, quorum status of that node, availability status of that node, and operational status of that node.

Each SCSI-blade process should be in quorum with the other nodes in the cluster. Any issues must be resolved before you proceed with the replacement.

- If you have a cluster with more than two nodes, it must be in quorum. If the cluster is not in quorum or a healthy controller shows false for eligibility and health, you must correct the issue before shutting down the impaired controller; see [Synchronize a node with the cluster](#).

### Steps

1. If AutoSupport is enabled, suppress automatic case creation by invoking an AutoSupport message:  

```
system node autosupport invoke -node * -type all -message MAINT=<# of hours>h
```

The following AutoSupport message suppresses automatic case creation for two hours: `cluster1:>`  

```
system node autosupport invoke -node * -type all -message MAINT=2h
```

2. Disable automatic giveback from the console of the healthy controller: 

```
storage failover modify -node local -auto-giveback false
```



When you see *Do you want to disable auto-giveback?*, enter *y*.

3. Take the impaired controller to the LOADER prompt:

If the impaired controller is displaying...	Then...
The LOADER prompt	Go to the next step.
Waiting for giveback...	Press Ctrl-C, and then respond <i>y</i> when prompted.
System prompt or password prompt	Take over or halt the impaired controller from the healthy controller: <pre>storage failover takeover -ofnode impaired_node_name</pre> When the impaired controller shows Waiting for giveback..., press Ctrl-C, and then respond <i>y</i> .

## Option 2: Controller is in a MetroCluster



Do not use this procedure if your system is in a two-node MetroCluster configuration.

To shut down the impaired controller, you must determine the status of the controller and, if necessary, take over the controller so that the healthy controller continues to serve data from the impaired controller storage.

- If you have a cluster with more than two nodes, it must be in quorum. If the cluster is not in quorum or a healthy controller shows false for eligibility and health, you must correct the issue before shutting down the impaired controller; see [Synchronize a node with the cluster](#).
- If you have a MetroCluster configuration, you must have confirmed that the MetroCluster Configuration State is configured and that the nodes are in an enabled and normal state (`metrocluster node show`).

### Steps

1. If AutoSupport is enabled, suppress automatic case creation by invoking an AutoSupport message:

```
system node autosupport invoke -node * -type all -message
MAINT=number_of_hours_downh
```

The following AutoSupport message suppresses automatic case creation for two hours:

```
cluster1:*> system node autosupport invoke -node * -type all -message
MAINT=2h
```

2. Disable automatic giveback from the console of the healthy controller: `storage failover modify -node local -auto-giveback false`
3. Take the impaired controller to the LOADER prompt:

If the impaired controller is displaying...	Then...
The LOADER prompt	Go to the next step.
Waiting for giveback...	Press Ctrl-C, and then respond <code>y</code> when prompted.
System prompt or password prompt (enter system password)	Take over or halt the impaired controller from the healthy controller: <code>storage failover takeover -ofnode <i>impaired_node_name</i></code>  When the impaired controller shows Waiting for giveback..., press Ctrl-C, and then respond <code>y</code> .

### Step 2: Replace the NVRAM module

To replace the NVRAM module, locate it in slot 6 in the chassis and follow the specific sequence of steps.

1. If you are not already grounded, properly ground yourself.
2. Remove the target NVRAM module from the chassis:
  - a. Depress the lettered and numbered cam button.

The cam button moves away from the chassis.

- b. Rotate the cam latch down until it is in a horizontal position.

The NVRAM module disengages from the chassis and moves out a few inches.

- c. Remove the NVRAM module from the chassis by pulling on the pull tabs on the sides of the module face.

[Animation - Replace the NVRAM module](#)

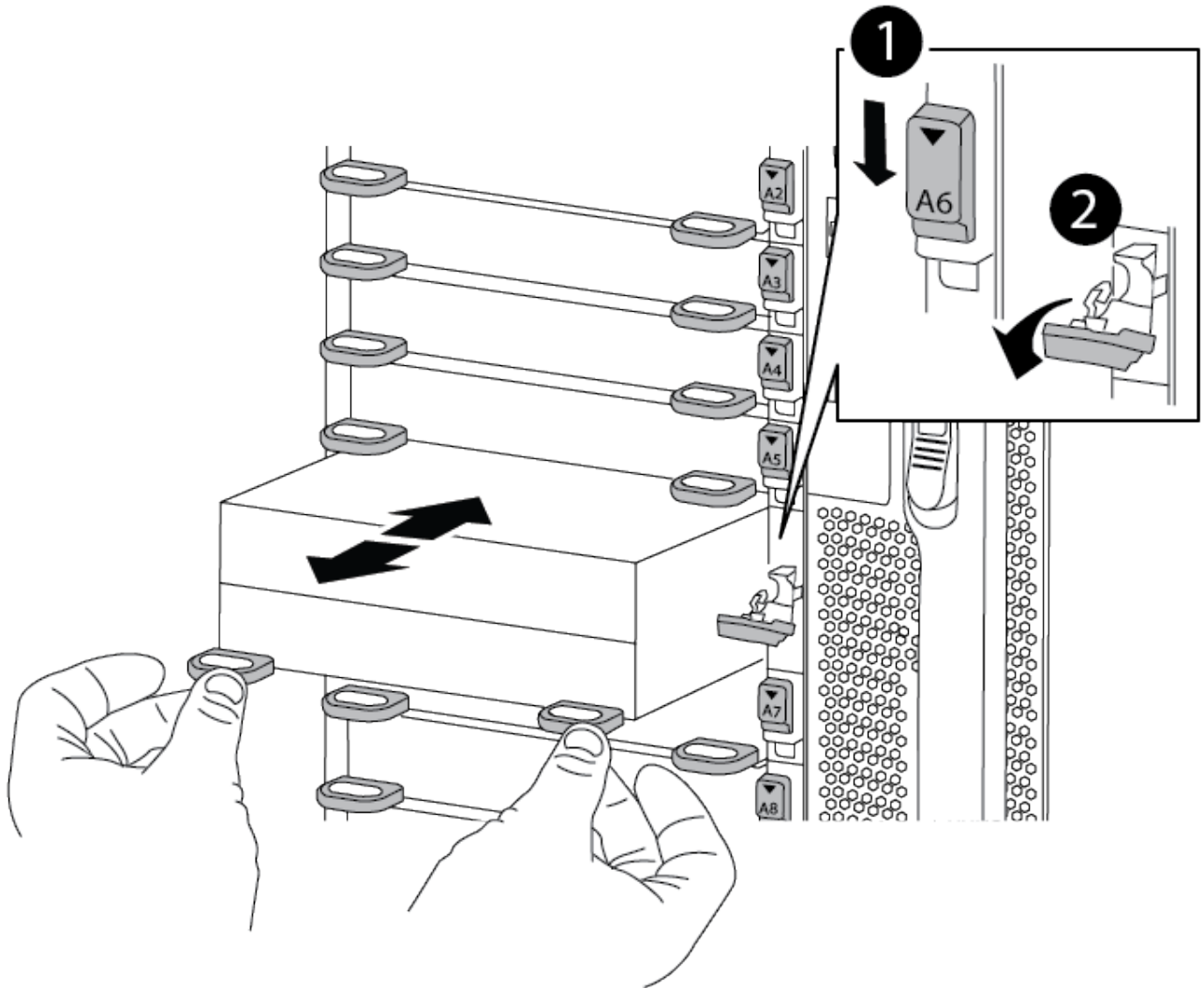

<b>1</b>	Lettered and numbered cam latch
<b>2</b>	Cam latch completely unlocked

- 3. Set the NVRAM module on a stable surface and remove the cover from the NVRAM module by pushing down on the blue locking button on the cover, and then, while holding down the blue button, slide the lid off the NVRAM module.

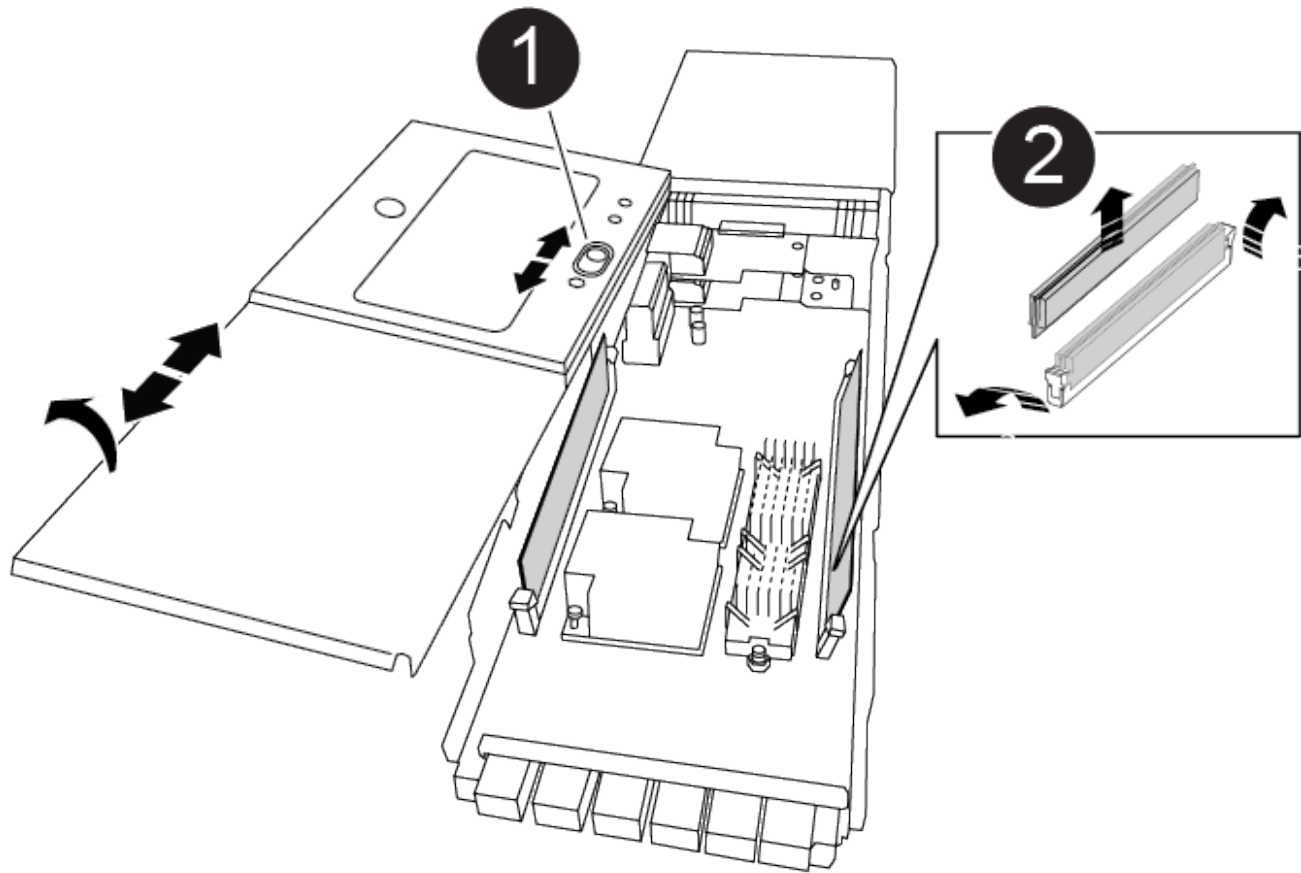

1	Cover locking button
2	DIMM and DIMM ejector tabs

4. Remove the DIMMs, one at a time, from the old NVRAM module and install them in the replacement NVRAM module.
5. Close the cover on the module.
6. Install the replacement NVRAM module into the chassis:
  - a. Align the module with the edges of the chassis opening in slot 6.
  - b. Gently slide the module into the slot until the lettered and numbered cam latch begins to engage with the I/O cam pin, and then push the cam latch all the way up to lock the module in place.

### Step 3: Replace a NVRAM DIMM

To replace NVRAM DIMMs in the NVRAM module, you must remove the NVRAM module, open the module, and then replace the target DIMM.

1. If you are not already grounded, properly ground yourself.
2. Remove the target NVRAM module from the chassis:
  - a. Depress the lettered and numbered cam button.

The cam button moves away from the chassis.



b. Rotate the cam latch down until it is in a horizontal position.

The NVRAM module disengages from the chassis and moves out a few inches.

c. Remove the NVRAM module from the chassis by pulling on the pull tabs on the sides of the module face.

[Animation - Replace NVRAM DIMM](#)

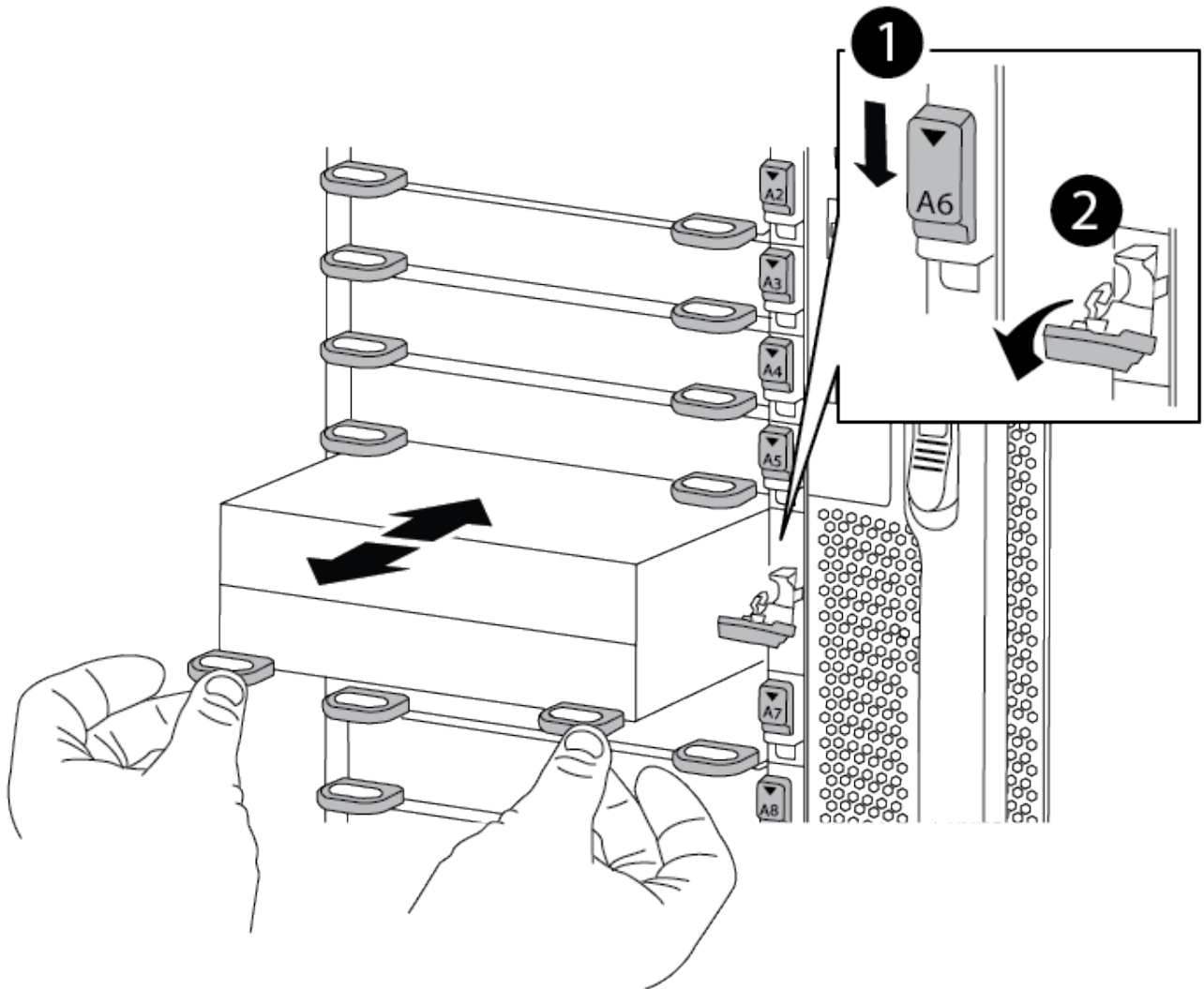

<b>1</b>	Lettered and numbered cam latch
<b>2</b>	cam latch completely unlocked

3. Set the NVRAM module on a stable surface and remove the cover from the NVRAM module by pushing down on the blue locking button on the cover, and then, while holding down the blue button, slide the lid off the NVRAM module.

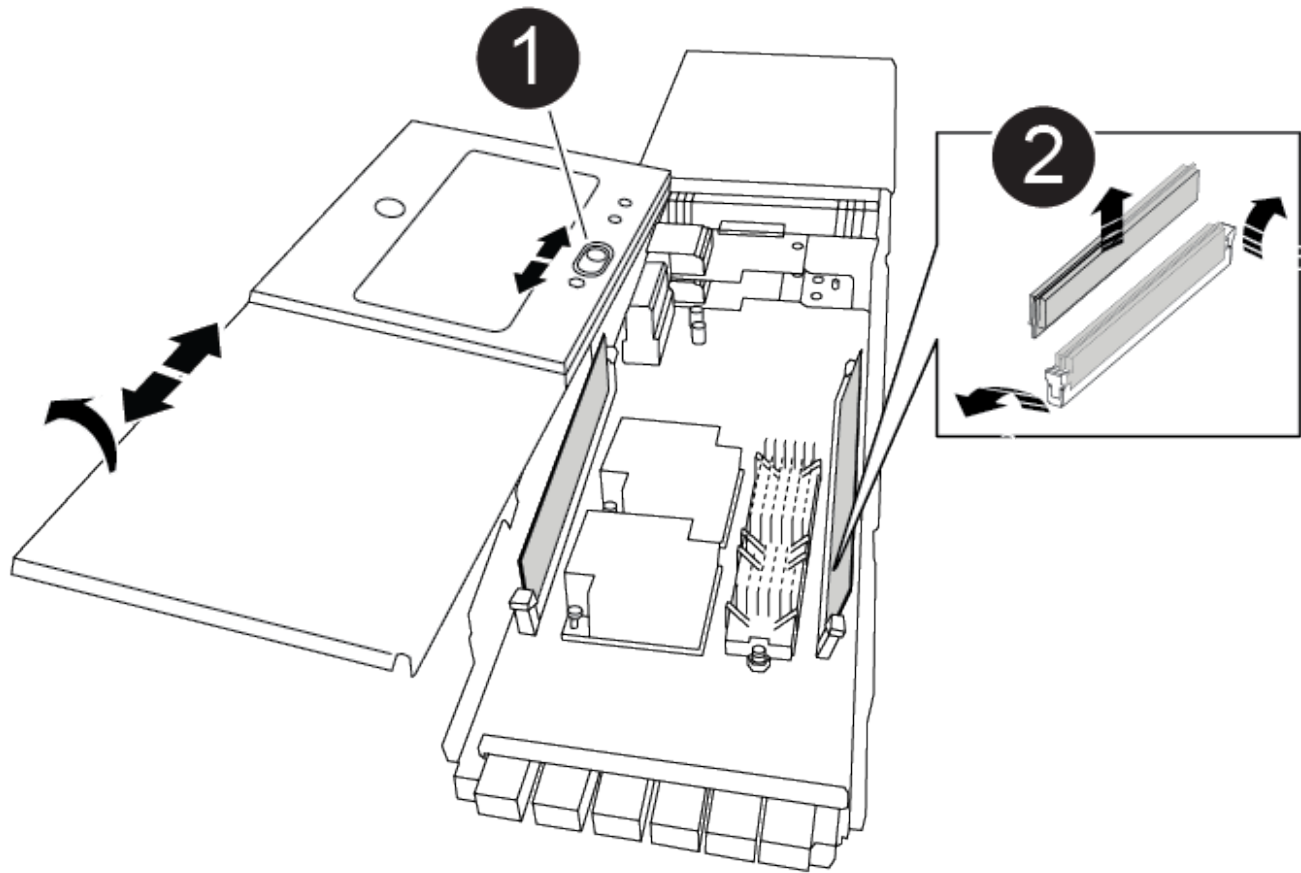

1	Cover locking button
2	DIMM and DIMM ejector tabs

4. Locate the DIMM to be replaced inside the NVRAM module, and then remove it by pressing down on the DIMM locking tabs and lifting the DIMM out of the socket.
5. Install the replacement DIMM by aligning the DIMM with the socket and gently pushing the DIMM into the socket until the locking tabs lock in place.
6. Close the cover on the module.
7. Install the NVRAM module into the chassis:
  - a. Align the module with the edges of the chassis opening in slot 6.
  - b. Gently slide the module into the slot until the lettered and numbered cam latch begins to engage with the I/O cam pin, and then push the cam latch all the way up to lock the module in place.

#### Step 4: Reboot the controller

After you replace the FRU, you must reboot the controller module.

1. To boot ONTAP from the LOADER prompt, enter `bye`.

## Step 5: Reassign disks

You must confirm the system ID change when you boot the replacement controller and then verify that the change was implemented.



Disk reassignment is only needed when replacing the NVRAM module and does not apply to NVRAM DIMM replacement.

### Steps

1. If the replacement controller is in Maintenance mode (showing the `*>` prompt), exit Maintenance mode and go to the LOADER prompt: `halt`
2. From the LOADER prompt on the replacement controller, boot the controller and entering `y` if you are prompted to override the system ID due to a system ID mismatch.
3. Wait until the `Waiting for giveback...` message is displayed on the console of the controller with the replacement module and then, from the healthy controller, verify that the new partner system ID has been automatically assigned: `storage failover show`

In the command output, you should see a message that the system ID has changed on the impaired controller, showing the correct old and new IDs. In the following example, `node2` has undergone replacement and has a new system ID of `151759706`.

```
node1:> storage failover show
```

Node	Partner	Takeover Possible	State Description
node1	node2	false	System ID changed on partner (Old: 151759706), In takeover
node2	node1	-	Waiting for giveback (HA mailboxes)

4. Give back the controller:
  - a. From the healthy controller, give back the replaced controller's storage: `storage failover giveback -ofnode replacement_node_name`

The replacement controller takes back its storage and completes booting.

If you are prompted to override the system ID due to a system ID mismatch, you should enter `y`.



If the giveback is vetoed, you can consider overriding the vetoes.

For more information, see the [Manual giveback commands](#) topic to override the veto.

- b. After the giveback has been completed, confirm that the HA pair is healthy and that takeover is possible: `storage failover show`

The output from the `storage failover show` command should not include the System ID changed on partner message.

5. Verify that the disks were assigned correctly: `storage disk show -ownership`

The disks belonging to the replacement controller should show the new system ID. In the following example, the disks owned by node1 now show the new system ID, 151759706:

```
node1:> storage disk show -ownership

Disk Aggregate Home Owner DR Home Home ID Owner ID DR Home ID
Reserver Pool
-----
-----
-----
-----
-----
1.0.0 aggr0_1 node1 node1 - 151759706 151759706 -
151759706 Pool10
1.0.1 aggr0_1 node1 node1 151759706 151759706 -
151759706 Pool10
.
.
.
```

6. If the system is in a MetroCluster configuration, monitor the status of the controller: `metrocluster node show`

The MetroCluster configuration takes a few minutes after the replacement to return to a normal state, at which time each controller will show a configured state, with DR Mirroring enabled and a mode of normal. The `metrocluster node show -fields node-systemid` command output displays the old system ID until the MetroCluster configuration returns to a normal state.

7. If the controller is in a MetroCluster configuration, depending on the MetroCluster state, verify that the DR home ID field shows the original owner of the disk if the original owner is a controller on the disaster site.

This is required if both of the following are true:

- The MetroCluster configuration is in a switchover state.
- The replacement controller is the current owner of the disks on the disaster site.

See [Disk ownership changes during HA takeover and MetroCluster switchover in a four-node MetroCluster configuration](#) for more information.

8. If your system is in a MetroCluster configuration, verify that each controller is configured: `metrocluster node show - fields configuration-state`

```

node1_siteA::> metrocluster node show -fields configuration-state

dr-group-id          cluster node          configuration-state
-----
-----
1 node1_siteA        node1mcc-001         configured
1 node1_siteA        node1mcc-002         configured
1 node1_siteB        node1mcc-003         configured
1 node1_siteB        node1mcc-004         configured

4 entries were displayed.

```

9. Verify that the expected volumes are present for each controller: `vol show -node node-name`
10. If storage encryption is enabled, you must restore functionality.
11. If you disabled automatic takeover on reboot, enable it from the healthy controller: `storage failover modify -node replacement-node-name -onreboot true`

### Step 6: Return the failed part to NetApp

Return the failed part to NetApp, as described in the RMA instructions shipped with the kit. See the [Part Return and Replacements](#) page for further information.

#### Swap out a power supply - ASA A900

Swapping out a power supply involves turning off, disconnecting, and removing the power supply and installing, connecting, and turning on the replacement power supply.

All other components in the system must be functioning properly; if not, you must contact technical support.

#### About this task

- The power supplies are redundant and hot-swappable.
- This procedure is written for replacing one power supply at a time.



It is a best practice to replace the power supply within two minutes of removing it from the chassis. The system continues to function, but ONTAP sends messages to the console about the degraded power supply until the power supply is replaced.

- There are four power supplies in the system.
- Power supplies are auto-ranging.



Do not mix PSUs with different efficiency ratings. Always replace like for like.

#### Steps

1. Identify the power supply you want to replace, based on console error messages or through the LEDs on the power supplies.
2. If you are not already grounded, properly ground yourself.

3. Turn off the power supply and disconnect the power cables:
  - a. Turn off the power switch on the power supply.
  - b. Open the power cable retainer, and then unplug the power cable from the power supply.
4. Press and hold the terra cotta button on the power supply handle, and then pull the power supply out of the chassis.

**CAUTION:**

When removing a power supply, always use two hands to support its weight.

[Animation - Remove/install PSU](#)

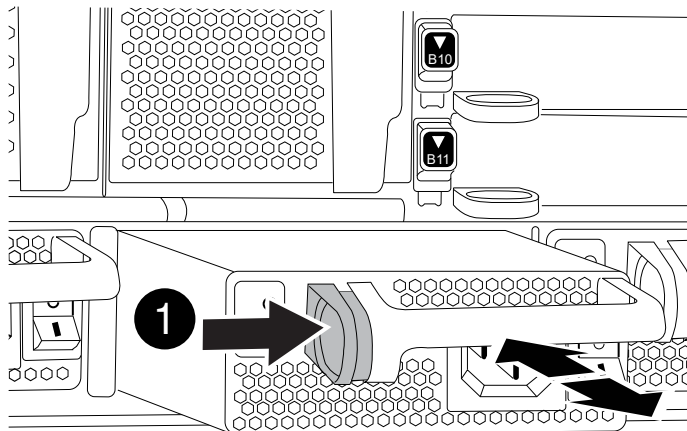

1	Locking button
---	----------------

5. Make sure that the on/off switch of the new power supply is in the Off position.
6. Using both hands, support and align the edges of the power supply with the opening in the system chassis, and then gently push the power supply into the chassis until it locks into place.

The power supplies are keyed and can only be installed one way.



Do not use excessive force when sliding the power supply into the system. You can damage the connector.

7. Reconnect the power supply cabling:
  - a. Reconnect the power cable to the power supply.
  - b. Secure the power cable to the power supply using the power cable retainer.

Once power is restored to the power supply, the status LED should be green.

8. Turn on the power to the new power supply, and then verify the operation of the power supply activity LEDs.

The green power LED lights when the PSU is fully inserted into the chassis and the amber attention LED flashes initially, but turns off after a few moments.

9. Return the failed part to NetApp, as described in the RMA instructions shipped with the kit. See the [Part Return and Replacements](#) page for further information.

#### **Replace the real-time clock battery - ASA A900**

You replace the real-time clock (RTC) battery in the controller module so that your system's services and applications that depend on accurate time synchronization continue to function.

- You can use this procedure with all versions of ONTAP supported by your system
- All other components in the system must be functioning properly; if not, you must contact technical support.

#### **Step 1: Shut down the impaired controller**

Shut down or take over the impaired controller using one of the following options.

## Option 1: Most systems

To shut down the impaired controller, you must determine the status of the controller and, if necessary, take over the controller so that the healthy controller continues to serve data from the impaired controller storage.

### About this task

- If you have a SAN system, you must have checked event messages (`cluster kernel-service show`) for the impaired controller SCSI blade. The `cluster kernel-service show` command (from `priv advanced` mode) displays the node name, quorum status of that node, availability status of that node, and operational status of that node.

Each SCSI-blade process should be in quorum with the other nodes in the cluster. Any issues must be resolved before you proceed with the replacement.

- If you have a cluster with more than two nodes, it must be in quorum. If the cluster is not in quorum or a healthy controller shows false for eligibility and health, you must correct the issue before shutting down the impaired controller; see [Synchronize a node with the cluster](#).

### Steps

1. If AutoSupport is enabled, suppress automatic case creation by invoking an AutoSupport message:

```
system node autosupport invoke -node * -type all -message MAINT=<# of hours>h
```

The following AutoSupport message suppresses automatic case creation for two hours: `cluster1:>`

```
system node autosupport invoke -node * -type all -message MAINT=2h
```

2. Disable automatic giveback from the console of the healthy controller: `storage failover modify -node local -auto-giveback false`



When you see *Do you want to disable auto-giveback?*, enter *y*.

3. Take the impaired controller to the LOADER prompt:

If the impaired controller is displaying...	Then...
The LOADER prompt	Go to the next step.
Waiting for giveback...	Press Ctrl-C, and then respond <i>y</i> when prompted.
System prompt or password prompt	Take over or halt the impaired controller from the healthy controller: <code>storage failover takeover -ofnode <i>impaired_node_name</i></code>  When the impaired controller shows <i>Waiting for giveback...</i> , press Ctrl-C, and then respond <i>y</i> .

## Option 2: Controller is in a MetroCluster





Do not use this procedure if your system is in a two-node MetroCluster configuration.

To shut down the impaired controller, you must determine the status of the controller and, if necessary, take over the controller so that the healthy controller continues to serve data from the impaired controller storage.

- If you have a cluster with more than two nodes, it must be in quorum. If the cluster is not in quorum or a healthy controller shows false for eligibility and health, you must correct the issue before shutting down the impaired controller; see [Synchronize a node with the cluster](#).
- If you have a MetroCluster configuration, you must have confirmed that the MetroCluster Configuration State is configured and that the nodes are in an enabled and normal state (`metrocluster node show`).

### Steps

1. If AutoSupport is enabled, suppress automatic case creation by invoking an AutoSupport message:

```
system node autosupport invoke -node * -type all -message
MAINT=number_of_hours_downh
```

The following AutoSupport message suppresses automatic case creation for two hours:

```
cluster1:*> system node autosupport invoke -node * -type all -message
MAINT=2h
```

2. Disable automatic giveback from the console of the healthy controller: `storage failover modify -node local -auto-giveback false`
3. Take the impaired controller to the LOADER prompt:

If the impaired controller is displaying...	Then...
The LOADER prompt	Go to the next step.
Waiting for giveback...	Press Ctrl-C, and then respond <code>y</code> when prompted.
System prompt or password prompt (enter system password)	Take over or halt the impaired controller from the healthy controller: <code>storage failover takeover -ofnode <i>impaired_node_name</i></code>  When the impaired controller shows Waiting for giveback..., press Ctrl-C, and then respond <code>y</code> .

### Step 2: Remove the controller

To access components inside the controller, you must first remove the controller module from the system and then remove the cover on the controller module.

1. If you are not already grounded, properly ground yourself.
2. Unplug the cables from the impaired controller module, and keep track of where the cables were connected.

3. Slide the terra cotta button on the cam handle downward until it unlocks.

[Animation - Remove the controller](#)

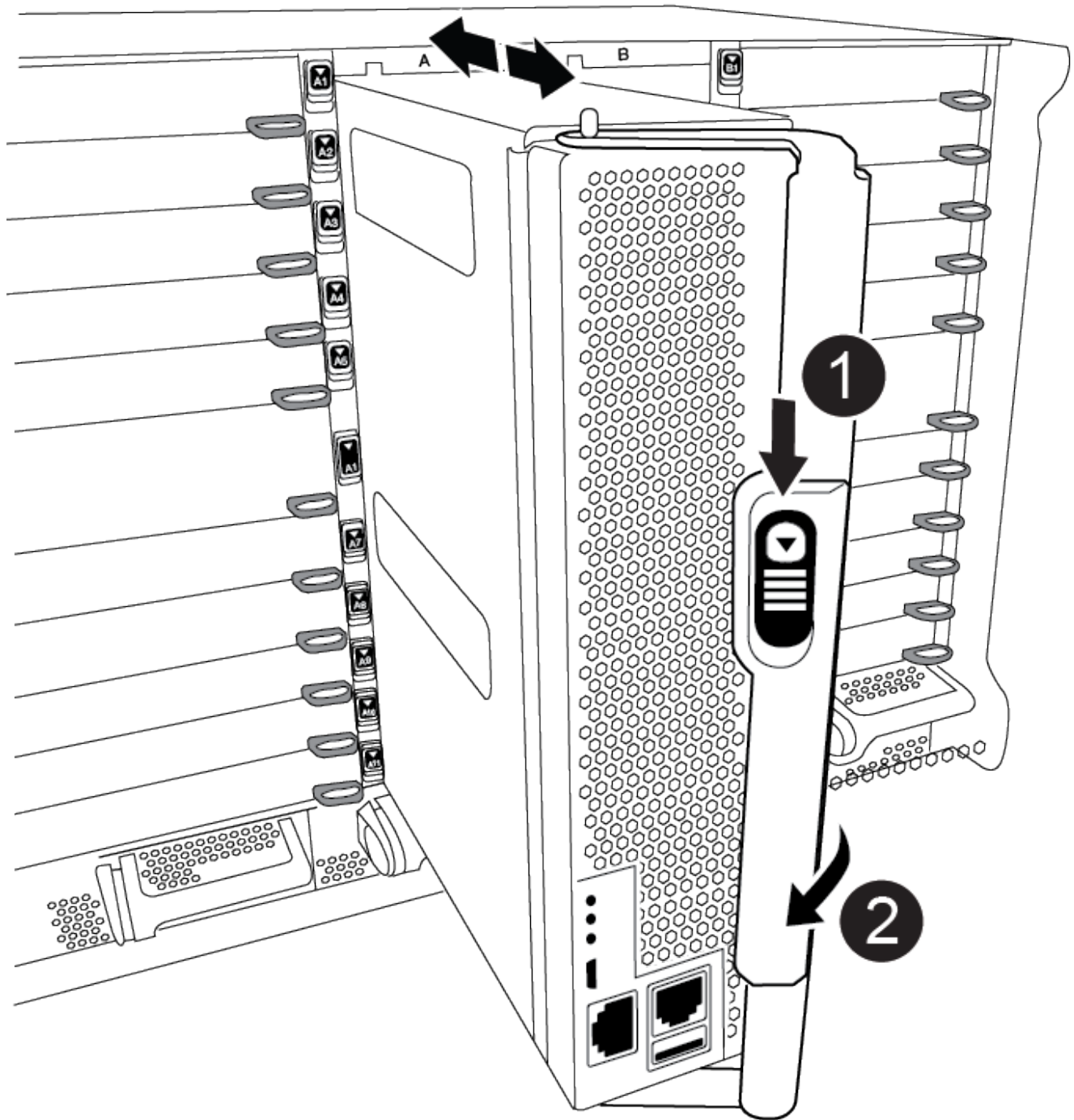

<b>1</b>	Cam handle release button
<b>2</b>	Cam handle

4. Rotate the cam handle so that it completely disengages the controller module from the chassis, and then slide the controller module out of the chassis.

Make sure that you support the bottom of the controller module as you slide it out of the chassis.

5. Place the controller module lid-side up on a stable, flat surface, press the blue button on the cover, slide the cover to the back of the controller module, and then swing the cover up and lift it off of the controller module.

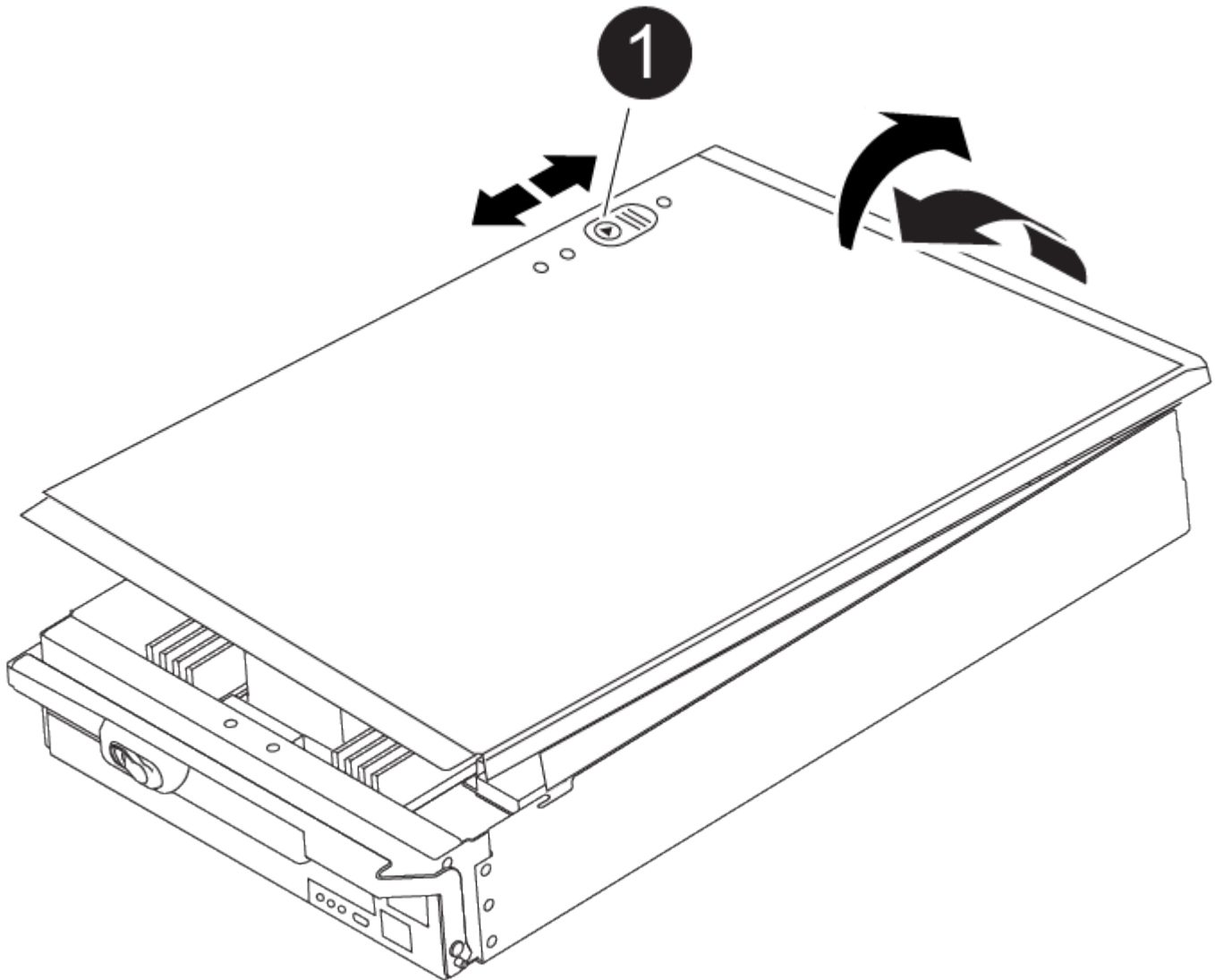

1

Controller module cover locking button

### Step 3: Replace the RTC battery

To replace the RTC battery, you must locate the failed battery in the controller module, remove it from the holder, and then install the replacement battery in the holder.

1. If you are not already grounded, properly ground yourself.
2. Locate the RTC battery.

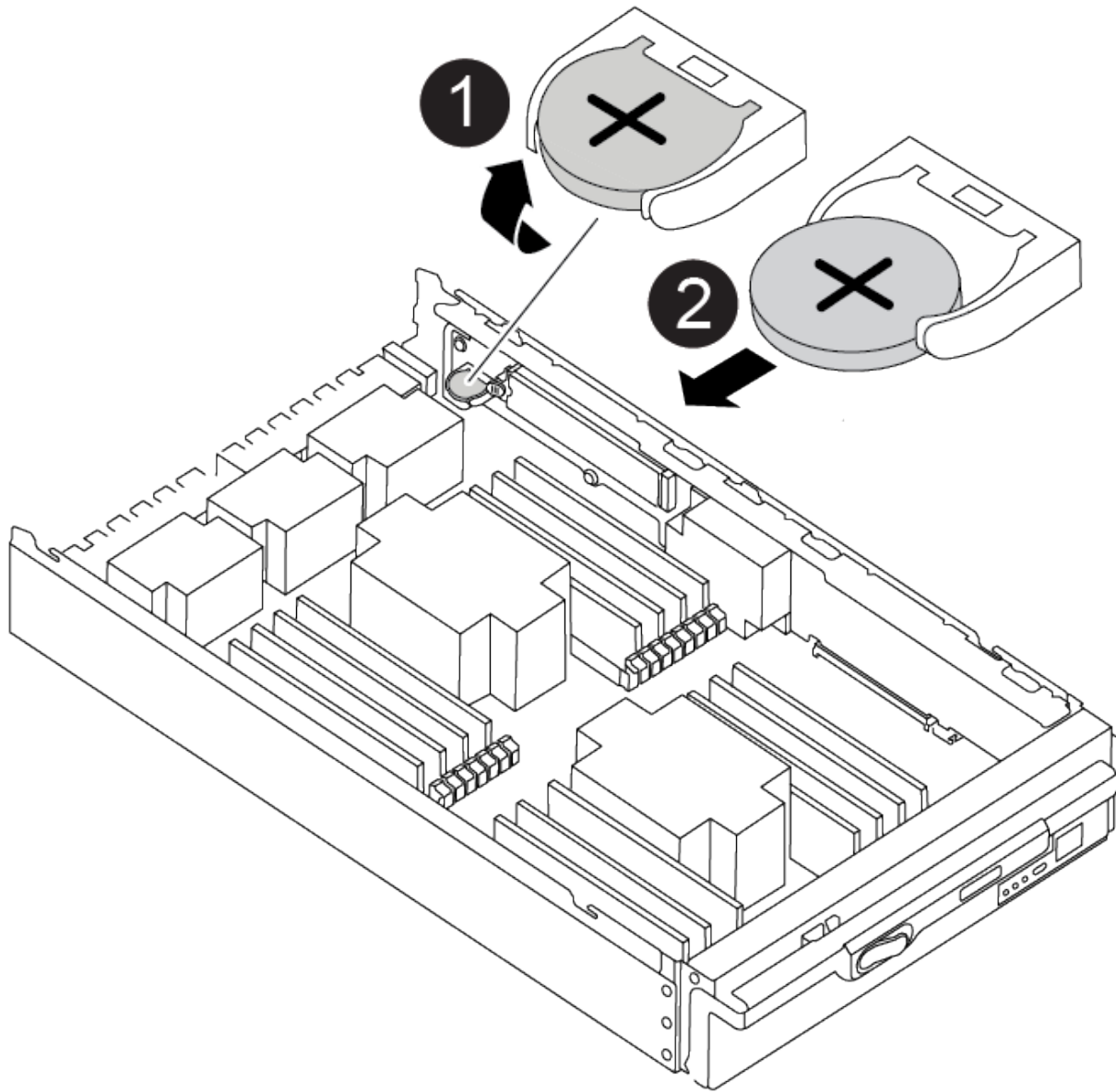

1	RTC battery
2	RTC battery housing

3. Gently push the battery away from the holder, rotate it away from the holder, and then lift it out of the holder.



Note the polarity of the battery as you remove it from the holder. The battery is marked with a plus sign and must be positioned in the holder correctly. A plus sign near the holder tells you how the battery should be positioned.

4. Remove the replacement battery from the antistatic shipping bag.

5. Locate the empty battery holder in the controller module.

6. Note the polarity of the RTC battery, and then insert it into the holder by tilting the battery at an angle and pushing down.
7. Visually inspect the battery to make sure that it is completely installed into the holder and that the polarity is correct.
8. Reinstall the controller module cover.

#### Step 4: Reinstall the controller module and set time/date

After you replace the RTC battery, you must reinstall the controller module. If the RTC battery has been left out of the controller module for more than 10 minutes, you may have to reset the time and date.

1. If you have not already done so, close the air duct or controller module cover.
2. Align the end of the controller module with the opening in the chassis, and then gently push the controller module halfway into the system.

Do not completely insert the controller module in the chassis until instructed to do so.

3. Recable the system, as needed.

If you removed the media converters (QSFPs or SFPs), remember to reinstall them if you are using fiber optic cables.

4. If the power supplies were unplugged, plug them back in and reinstall the power cable retainers.
5. Complete the reinstallation of the controller module:

- a. With the cam handle in the open position, firmly push the controller module in until it meets the midplane and is fully seated, and then close the cam handle to the locked position.



Do not use excessive force when sliding the controller module into the chassis to avoid damaging the connectors.

- b. If you have not already done so, reinstall the cable management device.
- c. Bind the cables to the cable management device with the hook and loop strap.
- d. Reconnect the power cables to the power supplies and to the power sources, and then turn on the power to start the boot process.
- e. Halt the controller at the LOADER prompt.



If your system stops at the boot menu, select the option for "Reboot node" and respond `y` when prompted, then boot to LOADER by pressing `Ctrl-C`.

1. Reset the time and date on the controller:
  - a. Check the date and time on the healthy controller with the `show date` command.
  - b. At the LOADER prompt on the target controller, check the time and date.
  - c. If necessary, modify the date with the `set date mm/dd/yyyy` command.
  - d. If necessary, set the time, in GMT, using the `set time hh:mm:ss` command.
  - e. Confirm the date and time on the target controller.

2. At the LOADER prompt, enter `bye` to reinitialize the PCIe cards and other components and let the controller reboot.
3. Return the controller to normal operation by giving back its storage: `storage failover giveback -ofnode impaired_node_name`
4. If automatic giveback was disabled, reenable it: `storage failover modify -node local -auto-giveback true`

### Step 5: Return the failed part to NetApp

Return the failed part to NetApp, as described in the RMA instructions shipped with the kit. See the [Part Return and Replacements](#) page for further information.

## All-Flash SAN Array (ASA) C-Series Systems

### ASA C250 systems

#### Install and setup

**Start here: Choose your installation and setup experience**

For most configurations, you can choose from different content formats.

- [Quick steps](#)

A printable PDF of step-by-step instructions with live links to additional content.

- [Video steps](#)

Video step-by-step instructions.

- [Detailed steps](#)

Online step-by-step instructions with live links to additional content.

If your system is in a MetroCluster IP configuration, see the [Install MetroCluster IP Configuration](#) instructions.

#### Quick steps - ASA C250

The Installation and Setup instructions give graphic instructions for a typical installation of your system, from racking and cabling, through initial system bring-up. Use this guide if you are familiar with installing NetApp systems.



The ASA A250 and ASA C250 use the same installation procedure as the AFF A250 system.

[AFF A250 Installation and Setup Instructions](#)

#### Videos - ASA C250

The following video shows how to install and cable your new system.

[Animation - Installation and Setup of an AFF A250](#)



The ASA C250 uses the same installation procedure as the AFF A250 system.

### Detailed steps - ASA C250

This section gives detailed step-by-step instructions for installing an ASA C250 system.

#### Step 1: Prepare for installation

To install your AFF A250 system, you need to create an account and register the system. You also need to inventory the appropriate number and type of cables for your system and collect specific network information.



Customers with specific power requirements must check HWU for their configuration options.

#### Before you begin

- Make sure you have access to the [NetApp Hardware Universe](#) (HWU) for information about site requirements.
- Make sure you have access to the [Release Notes for your version of ONTAP](#) for more information about this system.
- You need to provide the following at your site:
  - Rack space for the storage system
  - Phillips #2 screwdriver
  - Additional networking cables to connect your system to your network switch and laptop or console with a Web browser





#### Steps

1. Unpack the contents of all boxes.
2. Record the system serial number from the controllers.



3. Set up your account:
  - a. Log in to your existing account or create an account.
  - b. [Register](#) your system.
4. Download and install [NetApp Downloads: Config Advisor](#) on your laptop.
5. Inventory and make a note of the number and types of cables you received.

The following table identifies the types of cables you might receive. If you receive a cable not listed in the table, see the [NetApp Hardware Universe](#) to locate the cable and identify its use.

Type of cable...	Part number and length	Connector type	For...
25 GbE cable	X66240A-05 (112-00595), 0.5m; X66240-2 (112-00573), 2m		Cluster interconnect network
	X66240A-2 (112-00598), 2m; X66240A-5 (112-00600), 5m		Data
100 GbE cable	X66211-2 (112-00574), 2m; X66211-5 (112-00576), 5m		Storage
RJ-45 (order dependent)	Not applicable		Management network (BMC and wrench port) and Ethernet data (e0a and e0b)
Fibre Channel	X66250-2 (112-00342) 2m; X66250-5 (112-00344) 5m; X66250-15 (112-00346) 15m; X66250-30 (112-00347) 30m		
Micro-USB console cable	Not applicable		Console connection during software setup
Power cables	Not applicable		Powering up the system

6. Review the [ONTAP Configuration Guide](#) and collect the required information listed in that guide.

## Step 2: Install the hardware

You need to install your system in a 4-post rack or NetApp system cabinet, as applicable.

### Steps

1. Install the rail kits, as needed.
2. Install and secure your system using the instructions included with the rail kit.



You need to be aware of the safety concerns associated with the weight of the system.



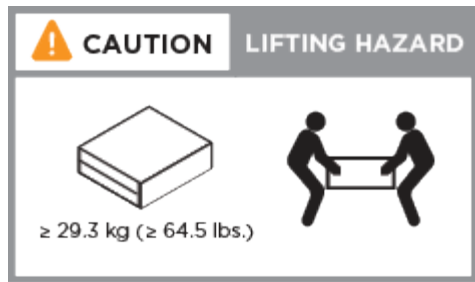

3. Identify and manage cables because this system does not have a cable management device.
4. Place the bezel on the front of the system.

### **Step 3: Cable controllers to cluster**

Cable the controllers to a cluster by using the two-node switchless cluster method or by using the cluster interconnect network method.

### Option 1: Two-node switchless cluster

The management, Fibre Channel, and data or host network ports on the controller modules are connected to switches. The cluster interconnect ports are cabled on both controller modules.

#### Before you begin

- Contact your network administrator for information about connecting the system to the switches.
- Be sure to check the illustration arrow for the proper cable connector pull-tab orientation.

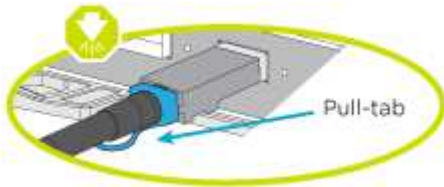

As you insert the connector, you should feel it click into place; if you do not feel it click, remove it, turn it around and try again.

#### About this task

Use the animation or the tabulated steps to complete the cabling between the controllers and the switches. Perform the steps on each controller.

#### Animation - Cable two-node switchless cluster

#### Steps

1. Use the the 25GbE cluster interconnect cable to connect the cluster interconnect ports e0c to e0c and e0d to e0d.

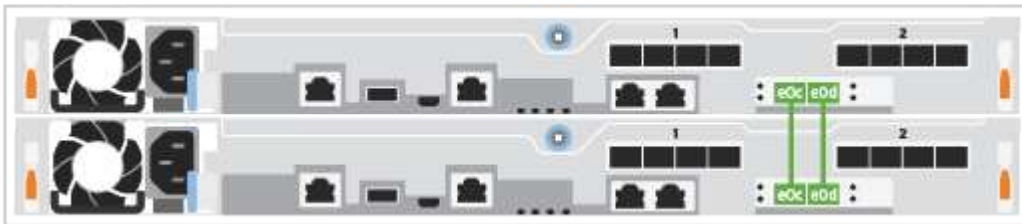

2. Cable the wrench ports to the management network switches with the RJ45 cables.

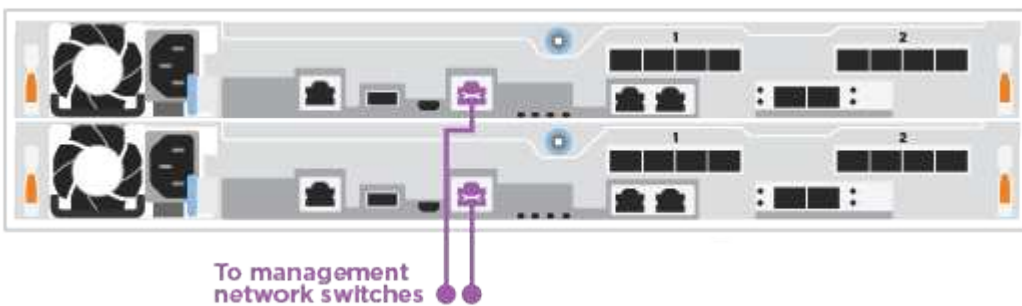

To management network switches



DO NOT plug in the power cords at this point.

### Option 2: Switched cluster

All ports on the controllers are connected to switches; cluster interconnect, management, Fibre Channel, and data or host network switches.

#### Before you begin

- Contact your network administrator for information about connecting the system to the switches.
- Be sure to check the illustration arrow for the proper cable connector pull-tab orientation.

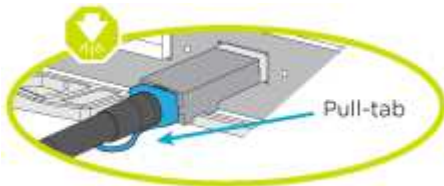

As you insert the connector, you should feel it click into place; if you do not feel it click, remove it, turn it around and try again.

#### About this task

Use the animation or the steps to complete the cabling between the controllers and the switches. Perform the steps on each controller.

[Animation - Cable switched cluster](#)

#### Steps

1. Cable the cluster interconnect ports e0c and e0d to the 25 GbE cluster interconnect switches.

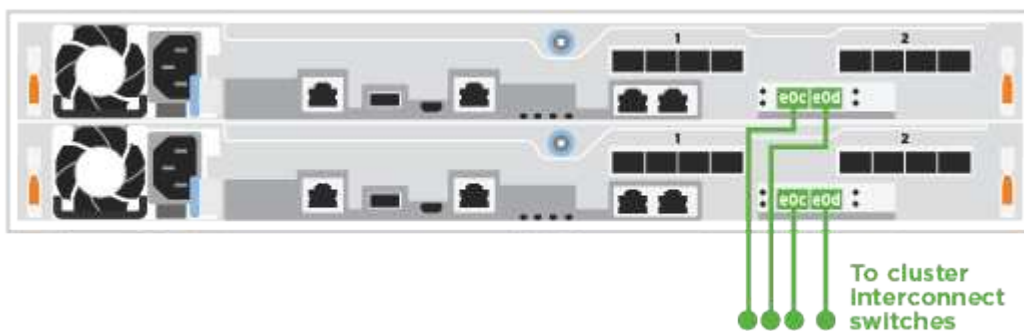

2. Cable the wrench ports to the management network switches with the RJ45 cables.

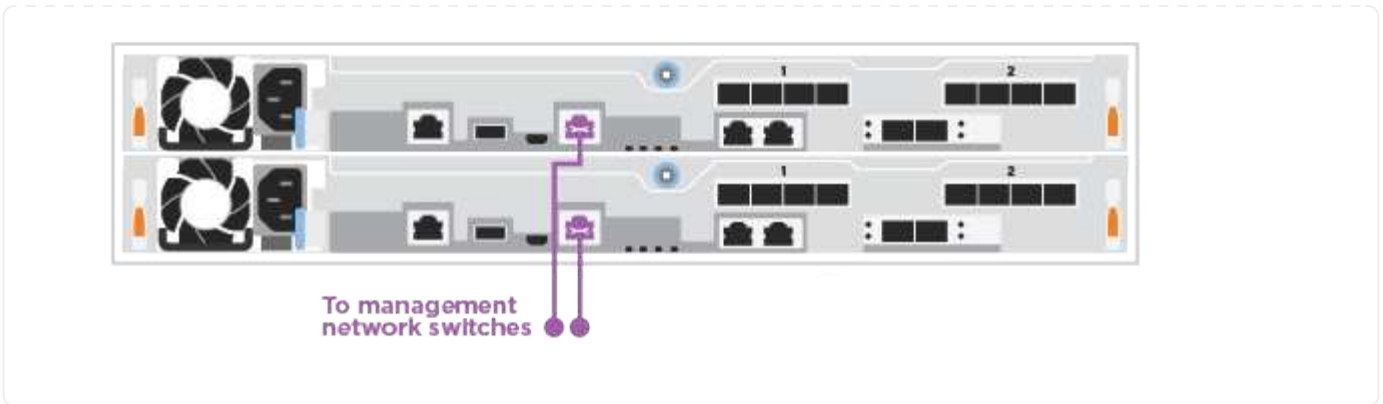

#### Step 4: Cable to host network or storage (Optional)

You have configuration-dependent optional cabling to the Fibre Channel or iSCSI host networks or direct-attached storage. This cabling is not exclusive; you can have cabling to a host network and storage.



[NetApp Hardware Universe](#) slot priority for host network cards (Fibre Channel or 25GbE) is slot 2. However, if you have both cards, the Fibre Channel card goes in slot 2 and the 25GbE card goes in slot 1 (as shown in the options below). If you have an external shelf, the storage card goes in slot 1, the only supported slot for shelves.

### Option 1: Cable to Fibre Channel host network

Fibre Channel ports on the controllers are connected to Fibre Channel host network switches.

#### Before you begin

- Contact your network administrator for information about connecting the system to the switches.
- Be sure to check the illustration arrow for the proper cable connector pull-tab orientation.

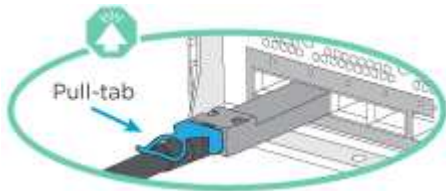

As you insert the connector, you should feel it click into place; if you do not feel it click, remove it, turn it around and try again..

#### About this task

Perform the following step on each controller module.

#### Steps

1. Cable ports 2a through 2d to the FC host switches.

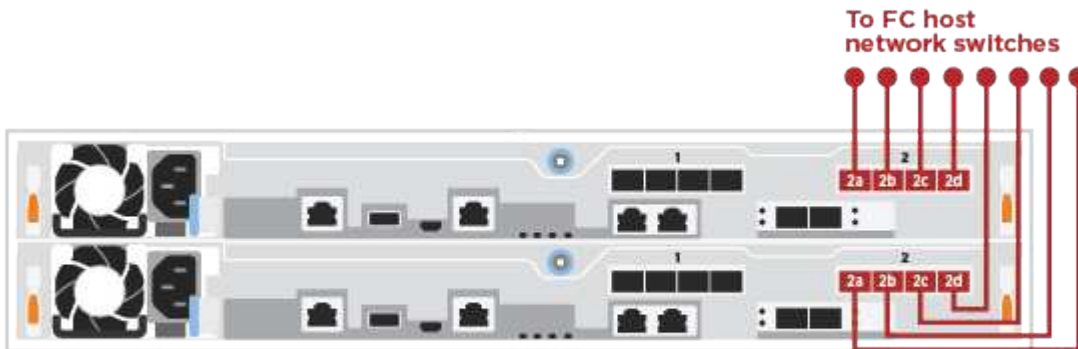

### Option 2: Cable to 25GbE data or host network

25GbE ports on the controllers are connected to 25GbE data or host network switches.

#### Before you begin

- Contact your network administrator for information about connecting the system to the switches.
- Be sure to check the illustration arrow for the proper cable connector pull-tab orientation.

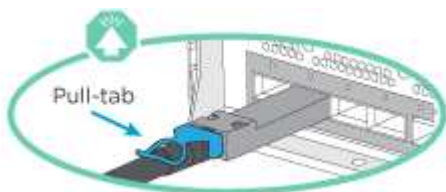



As you insert the connector, you should feel it click into place; if you do not feel it click, remove it, turn it around and try again.

### About this task

Perform the following step on each controller module.

### Steps

1. Cable ports e4a through e4d to the 10GbE host network switches.

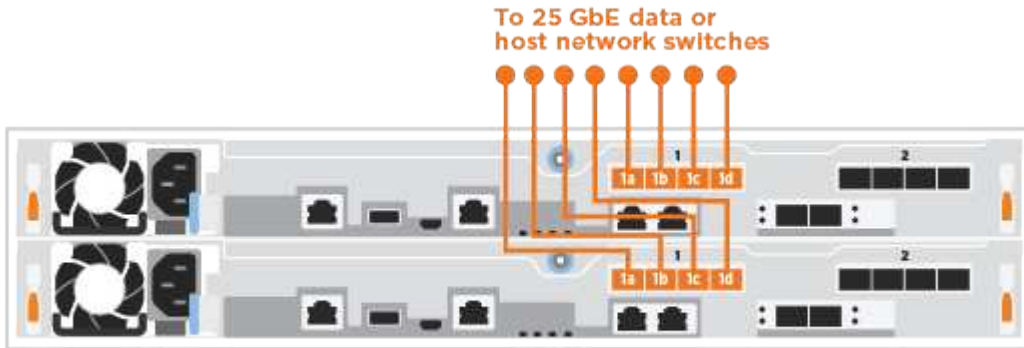

### Option 3: Cable controllers to single drive shelf

Cable each controller to the NSM modules on the NS224 drive shelf.

### Before you begin

Be sure to check the illustration arrow for the proper cable connector pull-tab orientation.

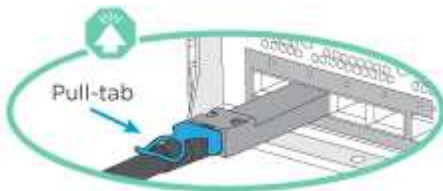

As you insert the connector, you should feel it click into place; if you do not feel it click, remove it, turn it around and try again.

### About this task

Use the animation or the tabulated steps to complete the cabling between the controllers and the single shelf. Perform the steps on each controller module.

[Animation - Cable the controllers to a single NS224](#)

### Steps

1. Cable controller A to the shelf.

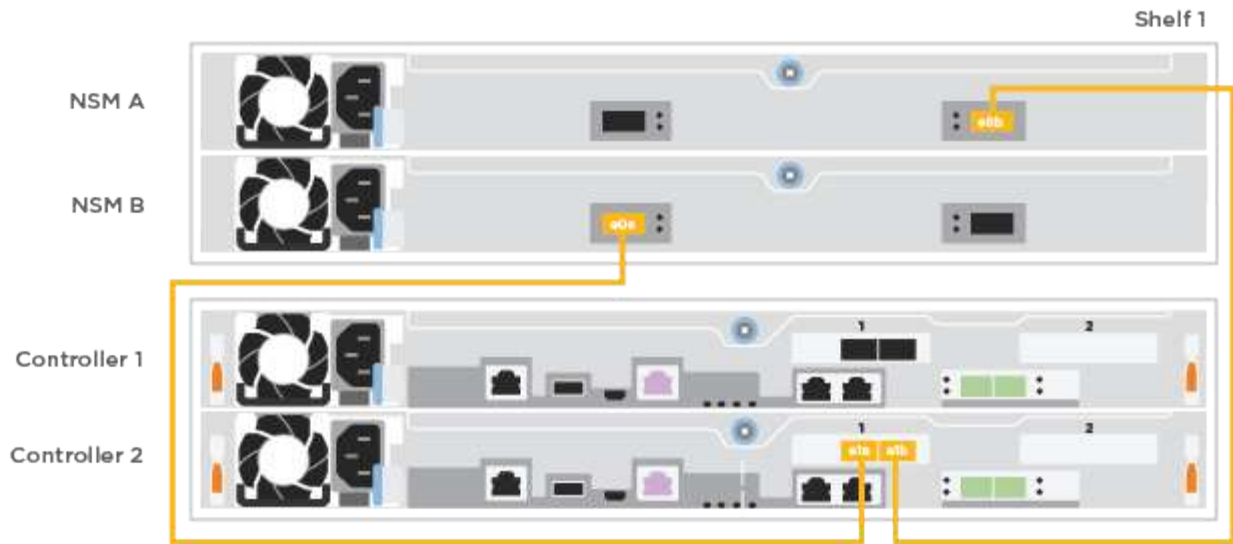

2. Cable controller B to the shelf.

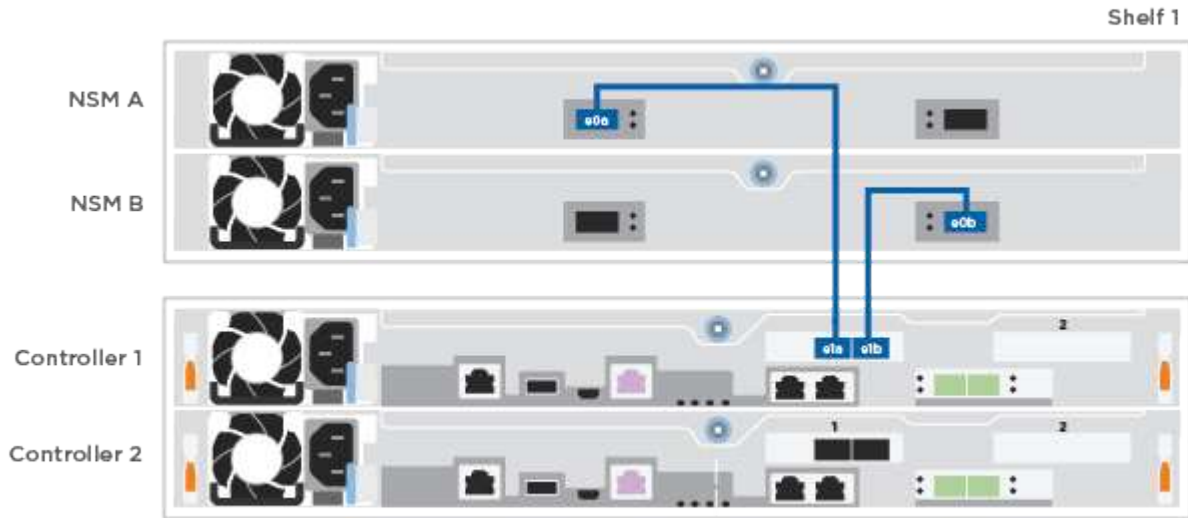

### Step 5: Complete system setup

Complete the system setup and configuration using cluster discovery with only a connection to the switch and laptop, or by connecting directly to a controller in the system and then connecting to the management switch.

### Option 1: If network discovery is enabled

If you have network discovery enabled on your laptop, you can complete system setup and configuration using automatic cluster discovery.

#### Steps

1. Plug the power cords into the controller power supplies, and then connect them to power sources on different circuits.

The system begins to boot. Initial booting may take up to eight minutes.

2. Make sure that your laptop has network discovery enabled.

See your laptop's online help for more information.

3. Use the animation to connect your laptop to the Management switch:

[Animation - Connect your laptop to the Management switch](#)

4. Select an ONTAP icon listed to discover:

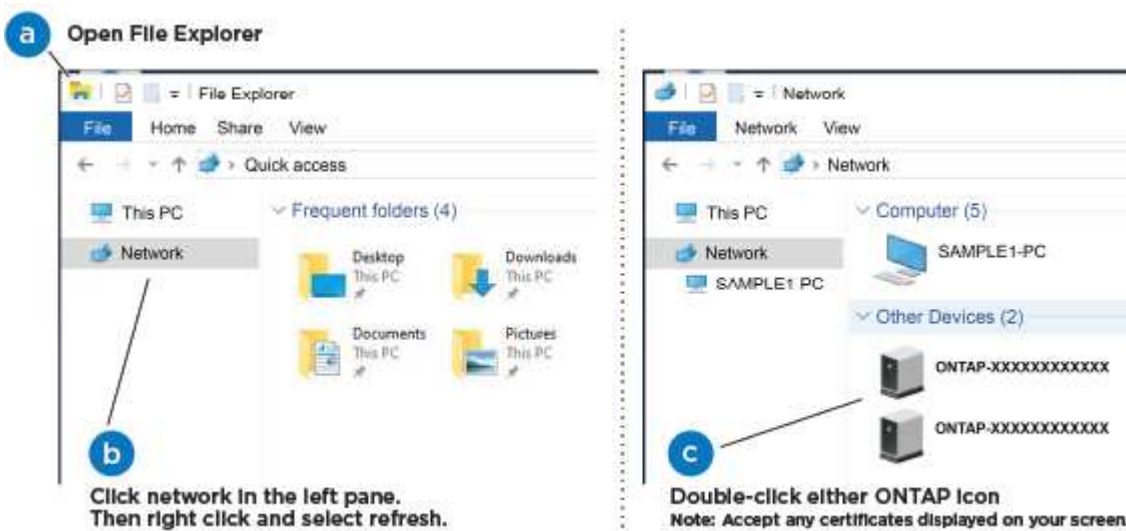

- a. Open File Explorer.
- b. Click **Network** in the left pane.
- c. Right-click and select **refresh**.
- d. Double-click either ONTAP icon and accept any certificates displayed on your screen.



XXXXX is the system serial number for the target node.

System Manager opens.

5. Use System Manager guided setup to configure your system using the data you collected in the [ONTAP Configuration Guide](#).
6. Verify the health of your system by running Config Advisor.
7. After you have completed the initial configuration, go to the [ONTAP & ONTAP System Manager](#)



[Documentation Resources](#) page for information about configuring additional features in ONTAP.

### Option 2: If network discovery is not enabled

If network discovery is not enabled on your laptop, you must complete the configuration and setup using this task.

#### Steps

1. Cable and configure your laptop or console:
  - a. Set the console port on the laptop or console to 115,200 baud with N-8-1.



See your laptop or console's online help for how to configure the console port.

- b. Connect the laptop or console to the switch on the management subnet.



- c. Assign a TCP/IP address to the laptop or console, using one that is on the management subnet.
2. Plug the power cords into the controller power supplies, and then connect them to power sources on different circuits.

The system begins to boot. Initial booting may take up to eight minutes.

3. Assign an initial node management IP address to one of the nodes.

If the management network has DHCP...	Then...
Configured	Record the IP address assigned to the new controllers.
Not configured	<ol style="list-style-type: none"><li>a. Open a console session using PuTTY, a terminal server, or the equivalent for your environment.   Check your laptop or console's online help if you do not know how to configure PuTTY.</li><li>b. Enter the management IP address when prompted by the script.</li></ol>

4. Using System Manager on your laptop or console, configure your cluster:
  - a. Point your browser to the node management IP address.



The format for the address is `https://x.x.x.x`.

- b. Configure the system using the data you collected in the [ONTAP Configuration Guide](#).
5. Verify the health of your system by running Config Advisor.
6. After you have completed the initial configuration, go to the [ONTAP & ONTAP System Manager Documentation Resources](#) page for information about configuring additional features in ONTAP.

## Maintain

### Maintain ASA C250 hardware

For the ASA C250 storage system, you can perform maintenance procedures on the following components.

#### Boot media

The boot media stores a primary and secondary set of boot image files that the system uses when it boots.

#### Chassis

The chassis is the physical enclosure housing all the controller components such as the controller/CPU unit, power supply, and I/O.

#### Controller

A controller consists of a board, firmware, and software. It controls the drives and implements the ONTAP functions.

#### DIMM

You must replace a DIMM (dual in-line memory module) when a memory mismatch is present, or you have a failed DIMM.

#### Drive

A drive is a device that provides the physical storage media for data.

#### Fan

The fan cools the controller.

#### Mezzanine card

A Mezzanine card is a printed circuit board that plugs directly into another plug-in card.

#### NVEM battery

A battery is included with the controller and preserves cached data if the AC power fails.

#### Power supply

A power supply provides a redundant power source in a controller shelf.

## Real-time clock battery

A real time clock battery preserves system date and time information if the power is off.

## Boot media

### Overview of boot media replacement - ASA C250

The boot media stores a primary and secondary set of system (boot image) files that the system uses when it boots.

#### Before you begin

- You must have a USB flash drive, formatted to MBR/FAT32, with the appropriate amount of storage to hold the `image_XXX.tgz` file.
- You also must copy the `image_XXX.tgz` file to the USB flash drive for later use in this procedure.

#### About this task

- The nondisruptive and disruptive methods for replacing a boot media both require you to restore the `var` file system:
  - For nondisruptive replacement, the HA pair must be connected to a network to restore the `var` file system.
  - For disruptive replacement, you do not need a network connection to restore the `var` file system, but the process requires two reboots.
- You must replace the failed component with a replacement FRU component you received from your provider.
- It is important that you apply the commands in these steps on the correct controller:
  - The *impaired* node is the controller on which you are performing maintenance.
  - The *healthy* node is the HA partner of the impaired controller.

### Check onboard encryption keys - ASA C250

Prior to shutting down the impaired controller and checking the status of the onboard encryption keys, you must check the status of the impaired controller, disable automatic giveback, and check which version of ONTAP is running on the system.

If you have a cluster with more than two nodes, it must be in quorum. If the cluster is not in quorum or a healthy controller shows false for eligibility and health, you must correct the issue before shutting down the impaired controller; see the [Synchronize a node with the cluster](#).

#### Steps

1. Check the status of the impaired controller:
  - If the impaired controller is at the login prompt, log in as `admin`.
  - If the impaired controller is at the LOADER prompt and is part of HA configuration, log in as `admin` on the healthy controller.
  - If the impaired controller is in a standalone configuration and at LOADER prompt, contact [mysupport.netapp.com](https://mysupport.netapp.com).
2. If AutoSupport is enabled, suppress automatic case creation by invoking an AutoSupport message:

```
system node autosupport invoke -node * -type all -message  
MAINT=number_of_hours_downh
```

The following AutoSupport message suppresses automatic case creation for two hours: `cluster1:*>`  
`system node autosupport invoke -node * -type all -message MAINT=2h`

3. Check the version of ONTAP the system is running on the impaired controller if up, or on the partner controller if the impaired controller is down, using the `version -v` command:
  - If `<Ino-DARE>` or `<1Ono-DARE>` is displayed in the command output, the system does not support NVE, proceed to shut down the controller.
  - If `<Ino-DARE>` is not displayed in the command output, and the system is running ONTAP 9.6 or later, go to the next section.
4. If the impaired controller is part of an HA configuration, disable automatic giveback from the healthy controller: `storage failover modify -node local -auto-giveback false` or `storage failover modify -node local -auto-giveback-after-panic false`

### Check NVE or NSE on systems running ONTAP 9.6 and later

Before shutting down the impaired controller, you need to verify whether the system has either NetApp Volume Encryption (NVE) or NetApp Storage Encryption (NSE) enabled. If so, you need to verify the configuration.

1. Verify whether NVE is in use for any volumes in the cluster: `volume show -is-encrypted true`

If any volumes are listed in the output, NVE is configured and you need to verify the NVE configuration. If no volumes are listed, check whether NSE is configured and in use.

2. Verify whether NSE is configured and in use: `storage encryption disk show`
  - If the command output lists the drive details with Mode & Key ID information, NSE is configured and you need to verify the NSE configuration and in use.
  - If no disks are shown, NSE is not configured.
  - If NVE and NSE are not configured, no drives are protected with NSE keys, it's safe to shut down the impaired controller.

### Verify NVE configuration

1. Display the key IDs of the authentication keys that are stored on the key management servers: `security key-manager key query`



After the ONTAP 9.6 release, you may have additional key manager types. The types are KMIP, AKV, and GCP. The process for confirming these types is the same as confirming external or onboard key manager types.

- If the Key Manager type displays `external` and the Restored column displays `yes`, it's safe to shut down the impaired controller.
- If the Key Manager type displays `onboard` and the Restored column displays `yes`, you need to complete some additional steps.
- If the Key Manager type displays `external` and the Restored column displays anything other than `yes`, you need to complete some additional steps.

- If the Key Manager type displays `onboard` and the Restored column displays anything other than `yes`, you need to complete some additional steps.
2. If the Key Manager type displays `onboard` and the Restored column displays `yes`, manually back up the OKM information:
    - a. Go to advanced privilege mode and enter `y` when prompted to continue: `set -priv advanced`
    - b. Enter the command to display the key management information: `security key-manager onboard show-backup`
    - c. Copy the contents of the backup information to a separate file or your log file. You'll need it in disaster scenarios where you might need to manually recover OKM.
    - d. Return to admin mode: `set -priv admin`
    - e. Shut down the impaired controller.
  3. If the Key Manager type displays `external` and the Restored column displays anything other than `yes`:
    - a. Restore the external key management authentication keys to all nodes in the cluster: `security key-manager external restore`

If the command fails, contact NetApp Support.

[mysupport.netapp.com](https://mysupport.netapp.com)

    - b. Verify that the Restored column equals `yes` for all authentication keys: `security key-manager key query`
    - c. Shut down the impaired controller.
  4. If the Key Manager type displays `onboard` and the Restored column displays anything other than `yes`:
    - a. Enter the onboard security key-manager sync command: `security key-manager onboard sync`



Enter the customer's 32 character, alphanumeric onboard key management passphrase at the prompt. If the passphrase cannot be provided, contact NetApp Support.  
[mysupport.netapp.com](https://mysupport.netapp.com)

- b. Verify the Restored column shows `yes` for all authentication keys: `security key-manager key query`
- c. Verify that the Key Manager type shows `onboard`, and then manually back up the OKM information.
- d. Go to advanced privilege mode and enter `y` when prompted to continue: `set -priv advanced`
- e. Enter the command to display the key management backup information: `security key-manager onboard show-backup`
- f. Copy the contents of the backup information to a separate file or your log file. You'll need it in disaster scenarios where you might need to manually recover OKM.
- g. Return to admin mode: `set -priv admin`
- h. You can safely shut down the controller.

## Verify NSE configuration

1. Display the key IDs of the authentication keys that are stored on the key management servers: `security key-manager key query -key-type NSE-AK`



After the ONTAP 9.6 release, you may have additional key manager types. The types are KMIP, AKV, and GCP. The process for confirming these types is the same as confirming external or onboard key manager types.

- If the Key Manager type displays `external` and the Restored column displays `yes`, it's safe to shut down the impaired controller.
  - If the Key Manager type displays `onboard` and the Restored column displays `yes`, you need to complete some additional steps.
  - If the Key Manager type displays `external` and the Restored column displays anything other than `yes`, you need to complete some additional steps.
  - If the Key Manager type displays `external` and the Restored column displays anything other than `yes`, you need to complete some additional steps.
2. If the Key Manager type displays `onboard` and the Restored column displays `yes`, manually back up the OKM information:
    - a. Go to advanced privilege mode and enter `y` when prompted to continue: `set -priv advanced`
    - b. Enter the command to display the key management information: `security key-manager onboard show-backup`
    - c. Copy the contents of the backup information to a separate file or your log file. You'll need it in disaster scenarios where you might need to manually recover OKM.
    - d. Return to admin mode: `set -priv admin`
    - e. You can safely shut down the controller.
  3. If the Key Manager type displays `external` and the Restored column displays anything other than `yes`:
    - a. Restore the external key management authentication keys to all nodes in the cluster: `security key-manager external restore`  
  
If the command fails, contact NetApp Support.  
  
[mysupport.netapp.com](https://mysupport.netapp.com)
    - b. Verify that the Restored column equals `yes` for all authentication keys: `security key-manager key query`
    - c. You can safely shut down the controller.
  4. If the Key Manager type displays `onboard` and the Restored column displays anything other than `yes`:
    - a. Enter the onboard security key-manager sync command: `security key-manager onboard sync`  
  
Enter the customer's 32 character, alphanumeric onboard key management passphrase at the prompt. If the passphrase cannot be provided, contact NetApp Support.  
  
[mysupport.netapp.com](https://mysupport.netapp.com)

- b. Verify the `Restored` column shows `yes` for all authentication keys: `security key-manager key query`
- c. Verify that the `Key Manager` type shows `onboard`, and then manually back up the OKM information.
- d. Go to advanced privilege mode and enter `y` when prompted to continue: `set -priv advanced`
- e. Enter the command to display the key management backup information: `security key-manager onboard show-backup`
- f. Copy the contents of the backup information to a separate file or your log file. You'll need it in disaster scenarios where you might need to manually recover OKM.
- g. Return to admin mode: `set -priv admin`
- h. You can safely shut down the controller.

## Shut down the controller - ASA C250

### Option 1: Most systems

After completing the NVE or NSE tasks, you need to complete the shutdown of the impaired controller.

#### Steps

- a. Take the impaired controller to the LOADER prompt:

If the impaired controller displays...	Then...
The LOADER prompt	Go to Remove controller module.
Waiting for giveback...	Press Ctrl-C, and then respond <code>y</code> when prompted.
System prompt or password prompt (enter system password)	Take over or halt the impaired controller from the healthy controller: <code>storage failover takeover -ofnode impaired_node_name</code>  When the impaired controller shows Waiting for giveback..., press Ctrl-C, and then respond <code>y</code> .

- b. From the LOADER prompt, enter: `printenv` to capture all boot environmental variables. Save the output to your log file.



This command may not work if the boot device is corrupted or non-functional.

### Option 2: Systems in a MetroCluster

After completing the NVE or NSE tasks, you need to complete the shutdown of the impaired controller.



Do not use this procedure if your system is in a two-node MetroCluster configuration.

To shut down the impaired controller, you must determine the status of the controller and, if necessary, take over the controller so that the healthy controller continues to serve data from the impaired controller storage.

- If you have a cluster with more than two nodes, it must be in quorum. If the cluster is not in quorum or a healthy controller shows false for eligibility and health, you must correct the issue before shutting down the impaired controller; see [Synchronize a node with the cluster](#).
- If you have a MetroCluster configuration, you must have confirmed that the MetroCluster Configuration State is configured and that the nodes are in an enabled and normal state (`metrocluster node show`).

### Steps

1. If AutoSupport is enabled, suppress automatic case creation by invoking an AutoSupport message:

```
system node autosupport invoke -node * -type all -message
MAINT=number_of_hours_downh
```

The following AutoSupport message suppresses automatic case creation for two hours: `cluster1:*>`

```
system node autosupport invoke -node * -type all -message MAINT=2h
```

2. Disable automatic giveback from the console of the healthy controller: `storage failover modify -node local -auto-giveback false`
3. Take the impaired controller to the LOADER prompt:

If the impaired controller is displaying...	Then...
The LOADER prompt	Go to the next step.
Waiting for giveback...	Press Ctrl-C, and then respond <code>y</code> when prompted.
System prompt or password prompt (enter system password)	Take over or halt the impaired controller from the healthy controller: <pre>storage failover takeover -ofnode impaired_node_name</pre> <p>When the impaired controller shows Waiting for giveback..., press Ctrl-C, and then respond <code>y</code>.</p>

## Replace the boot media - ASA C250

To replace the boot media, you must remove the impaired controller module, install the replacement boot media, and transfer the boot image to a USB flash drive.

### Step 1: Remove the controller module

To access components inside the controller module, you must first remove the controller module from the system, and then remove the cover on the controller module.

#### Steps

1. If you are not already grounded, properly ground yourself.
2. Unplug the controller module power supplies from the source.
3. Release the power cable retainers, and then unplug the cables from the power supplies.



4. Insert your forefinger into the latching mechanism on either side of the controller module, press the lever with your thumb, and gently pull the controller a few inches out of the chassis.



If you have difficulty removing the controller module, place your index fingers through the finger holes from the inside (by crossing your arms).

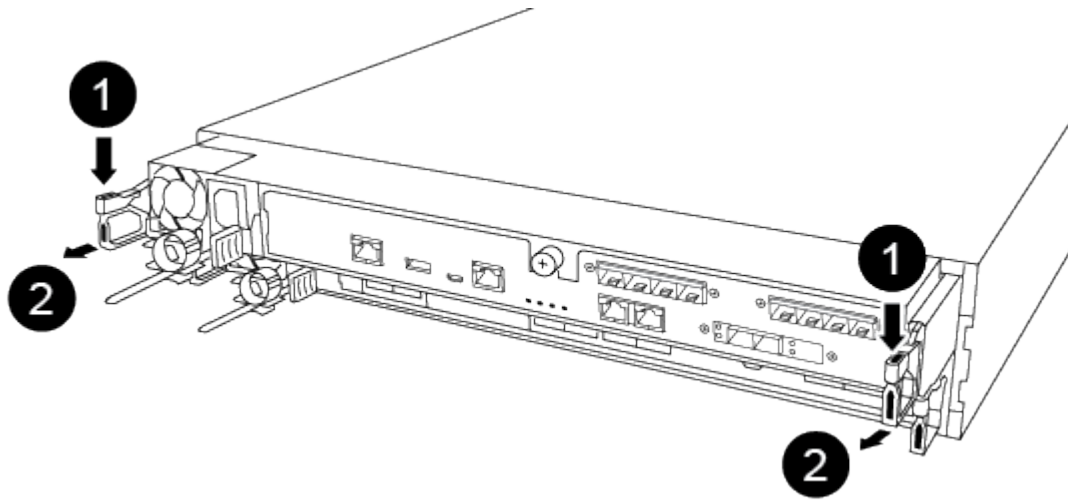

1	Lever
2	Latching mechanism

5. Using both hands, grasp the controller module sides and gently pull it out of the chassis and set it on a flat, stable surface.
6. Turn the thumbscrew on the front of the controller module anti-clockwise and open the controller module cover.

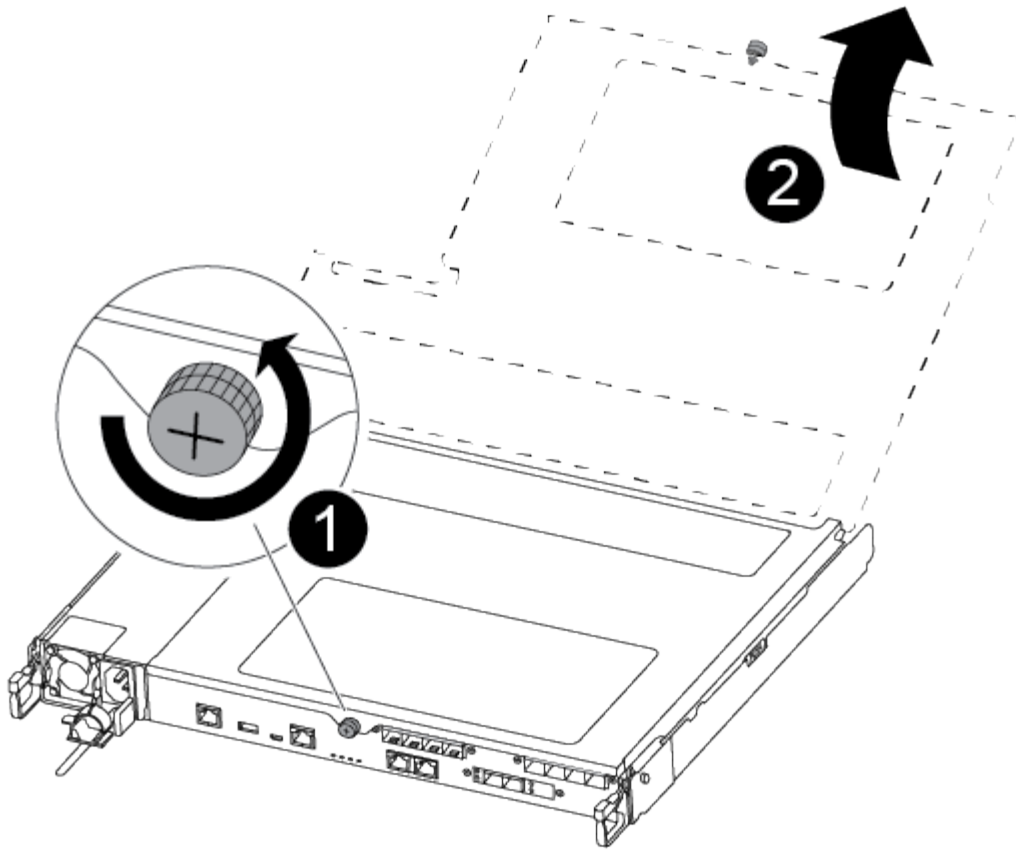

1	Thumbscrew
2	Controller module cover.

7. Lift out the air duct cover.

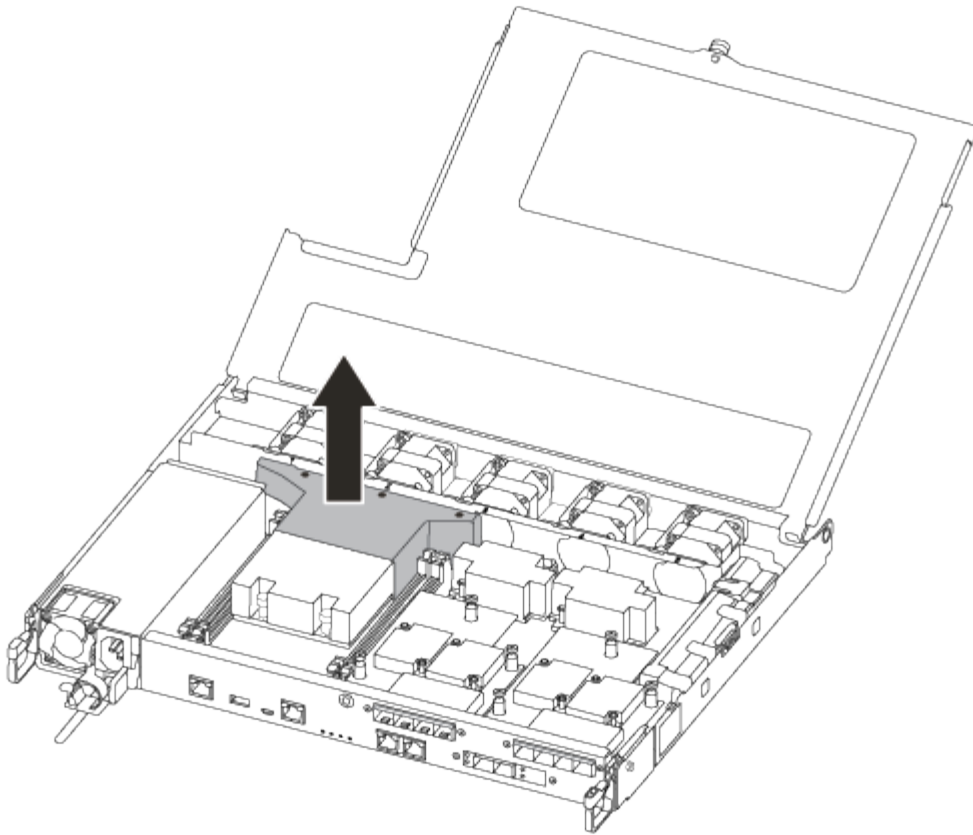

## Step 2: Replace the boot media

You locate the failed boot media in the controller module by removing the air duct on the controller module before you can replace the boot media.

You need a #1 magnetic Phillips head screwdriver to remove the screw that holds the boot media in place. Due to the space constraints within the controller module, you should also have a magnet to transfer the screw on to so that you do not lose it.

You can use the following video or the tabulated steps to replace the boot media:

[Animation - Replace the boot media](#)

1. Locate and replace the impaired boot media from the controller module.

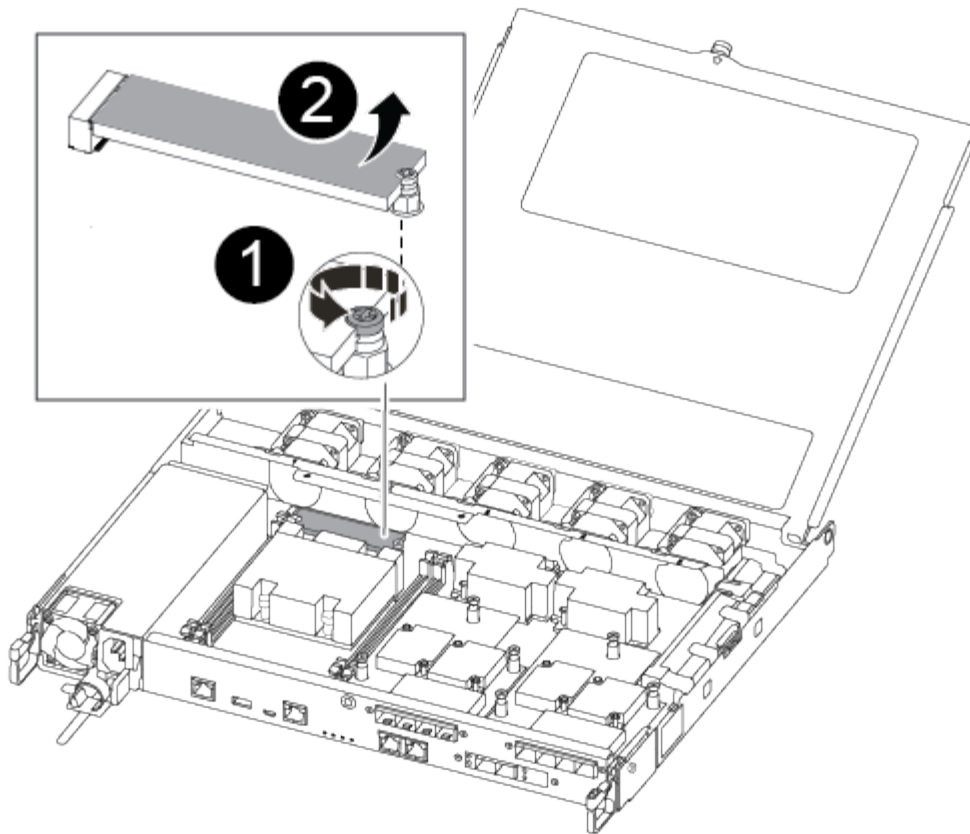

<p><b>1</b></p>	<p>Remove the screw securing the boot media to the motherboard in the controller module.</p>
<p><b>2</b></p>	<p>Lift the boot media out of the controller module.</p>

2. Using the #1 magnetic screwdriver, remove the screw from the impaired boot media, and set it aside safely on the magnet.
3. Gently lift the impaired boot media directly out of the socket and set it aside.
4. Remove the replacement boot media from the antistatic shipping bag and align it into place on the controller module.
5. Using the #1 magnetic screwdriver, insert and tighten the screw on the boot media.



Do not apply force when tightening the screw on the boot media; you might crack it.

### Step 3: Transfer the boot image to the boot media

The replacement boot media that you installed is without a boot image so you need to transfer a boot image using a USB flash drive.

- You must have a USB flash drive, formatted to MBR/FAT32, with at least 4GB capacity
- A copy of the same image version of ONTAP as what the impaired controller was running. You can download the appropriate image from the Downloads section on the NetApp Support Site
  - If NVE is enabled, download the image with NetApp Volume Encryption, as indicated in the download

button.

- If NVE is not enabled, download the image without NetApp Volume Encryption, as indicated in the download button.
  - If your system is an HA pair, you must have a network connection.
  - If your system is a stand-alone system you do not need a network connection, but you must perform an additional reboot when restoring the var file system.
1. Download and copy the appropriate service image from the NetApp Support Site to the USB flash drive.
  2. Download the service image to your work space on your laptop.
  3. Unzip the service image.



If you are extracting the contents using Windows, do not use winzip to extract the netboot image. Use another extraction tool, such as 7-Zip or WinRAR.

There are two folders in the unzipped service image file:

- boot
  - efi
4. Copy the efi folder to the top directory on the USB flash drive.

The USB flash drive should have the efi folder and the same Service Image (BIOS) version of what the impaired controller is running.

5. Remove the USB flash drive from your laptop.
6. If you have not already done so, install the air duct.

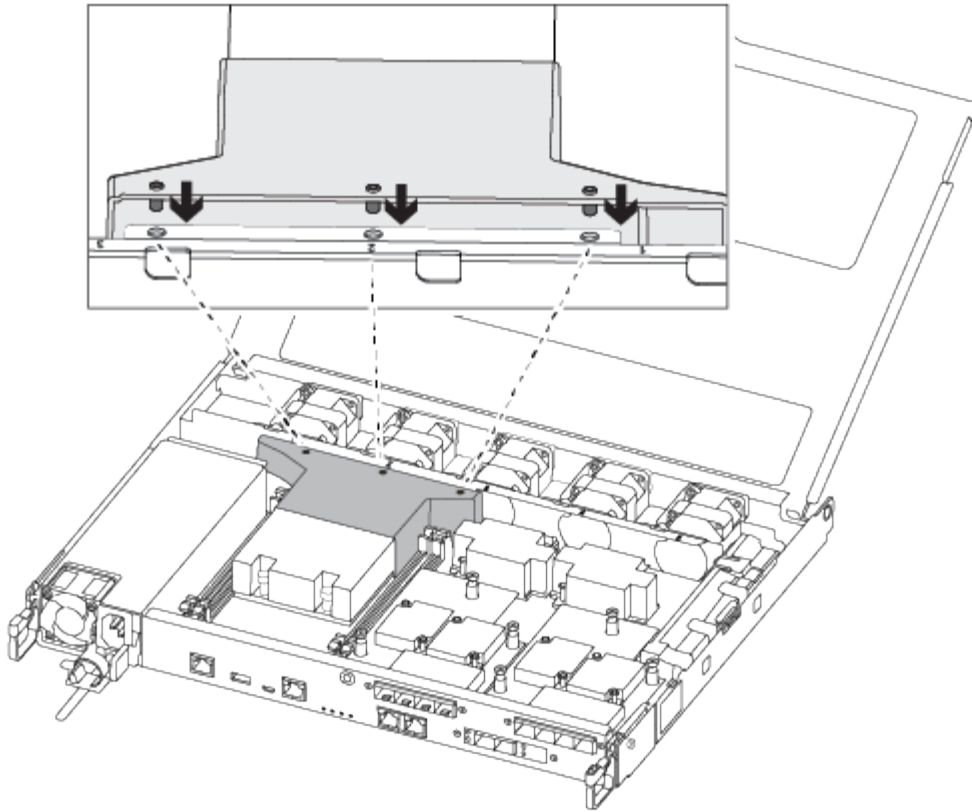

7. Close the controller module cover and tighten the thumbscrew.

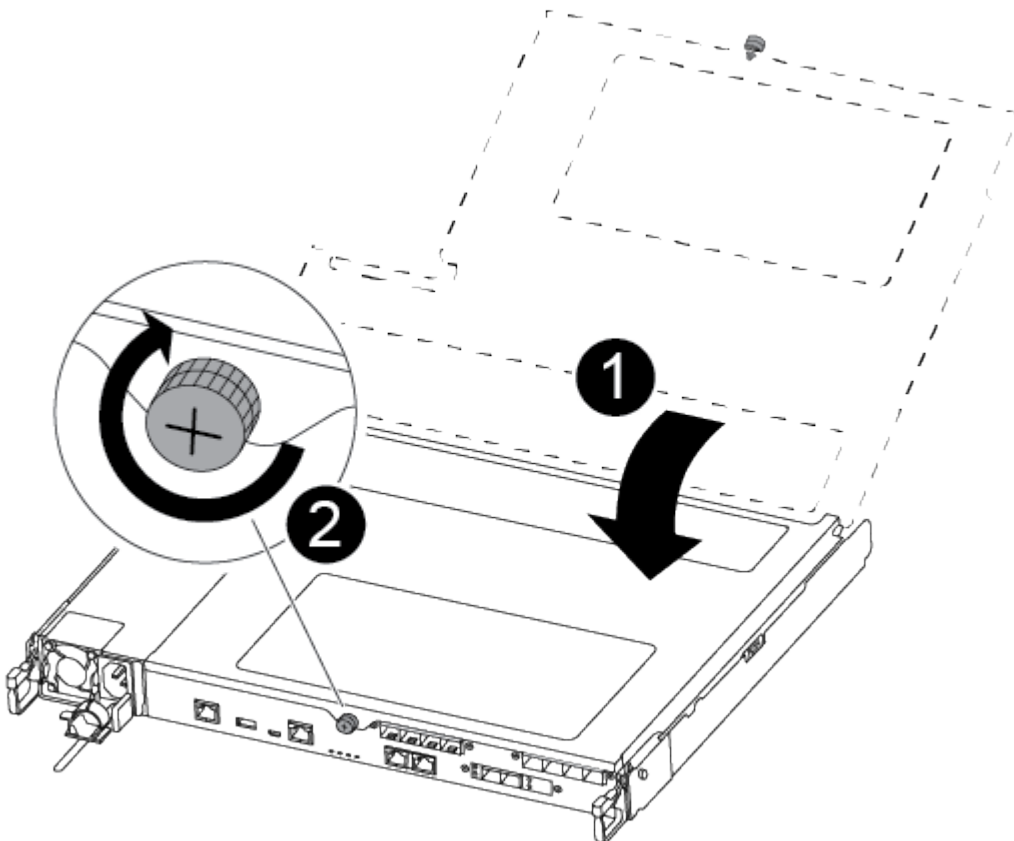

<b>1</b>	Controller module cover
<b>2</b>	Thumbscrew

8. Align the end of the controller module with the opening in the chassis, and then gently push the controller module halfway into the system.
9. Plug the power cable into the power supply and reinstall the power cable retainer.
10. Insert the USB flash drive into the USB slot on the controller module.

Make sure that you install the USB flash drive in the slot labeled for USB devices, and not in the USB console port.

11. Push the controller module all the way into the chassis:
12. Place your index fingers through the finger holes from the inside of the latching mechanism.
13. Press your thumbs down on the orange tabs on top of the latching mechanism and gently push the controller module over the stop.
14. Release your thumbs from the top of the latching mechanisms and continue pushing until the latching mechanisms snap into place.

The controller module begins to boot as soon as it is fully seated in the chassis. Be prepared to interrupt the boot process.

The controller module should be fully inserted and flush with the edges of the chassis.

15. Interrupt the boot process to stop at the LOADER prompt by pressing Ctrl-C when you see Starting AUTOBOOT press Ctrl-C to abort....

If you miss this message, press Ctrl-C, select the option to boot to Maintenance mode, and then halt the controller to boot to LOADER.

16. For systems with one controller in the chassis, reconnect the power and turn on the power supplies.

The system begins to boot and stops at the LOADER prompt.

17. Set your network connection type at the LOADER prompt:

- If you are configuring DHCP: `ifconfig e0a -auto`



The target port you configure is the target port you use to communicate with the impaired controller from the healthy controller during var file system restore with a network connection. You can also use the e0M port in this command.

- If you are configuring manual connections: `ifconfig e0a -addr=filer_addr -mask=netmask -gw=gateway-dns=dns_addr-domain=dns_domain`
  - `filer_addr` is the IP address of the storage system.
  - `netmask` is the network mask of the management network that is connected to the HA partner.
  - `gateway` is the gateway for the network.

- `dns_addr` is the IP address of a name server on your network.
- `dns_domain` is the Domain Name System (DNS) domain name.

If you use this optional parameter, you do not need a fully qualified domain name in the netboot server URL. You need only the server's host name.



Other parameters might be necessary for your interface. You can enter `help ifconfig` at the firmware prompt for details.

### Boot the recovery image - ASA C250

You must boot the ONTAP image from the USB drive, restore the file system, and verify the environmental variables.

1. From the LOADER prompt, boot the recovery image from the USB flash drive: `boot_recovery`

The image is downloaded from the USB flash drive.

2. When prompted, either enter the name of the image or accept the default image displayed inside the brackets on your screen.
3. Restore the `var` file system:

If your system has...	Then...
A network connection	<ol style="list-style-type: none"> <li>a. Press <code>y</code> when prompted to restore the backup configuration.</li> <li>b. Set the healthy controller to advanced privilege level: <code>set -privilege advanced</code></li> <li>c. Run the restore backup command: <code>system node restore-backup -node local -target-address <i>impaired_node_IP_address</i></code></li> <li>d. Return the controller to admin level: <code>set -privilege admin</code></li> <li>e. Press <code>y</code> when prompted to use the restored configuration.</li> <li>f. Press <code>y</code> when prompted to reboot the controller.</li> </ol>
No network connection	<ol style="list-style-type: none"> <li>a. Press <code>n</code> when prompted to restore the backup configuration.</li> <li>b. Reboot the system when prompted by the system.</li> <li>c. Select the <b>Update flash from backup config</b> (sync flash) option from the displayed menu.</li> </ol> <p>If you are prompted to continue with the update, press <code>y</code>.</p>



If your system has...	Then...
No network connection and is in a MetroCluster IP configuration	<p>a. Press <code>n</code> when prompted to restore the backup configuration.</p> <p>b. Reboot the system when prompted by the system.</p> <p>c. Wait for the iSCSI storage connections to connect.</p> <p>You can proceed after you see the following messages:</p> <pre data-bbox="672 394 1489 1255"> date-and-time [node- name:iscsi.session.stateChanged:notice]: iSCSI session state is changed to Connected for the target iSCSI-target (type: dr_auxiliary, address: ip-address). date-and-time [node- name:iscsi.session.stateChanged:notice]: iSCSI session state is changed to Connected for the target iSCSI-target (type: dr_partner, address: ip-address). date-and-time [node- name:iscsi.session.stateChanged:notice]: iSCSI session state is changed to Connected for the target iSCSI-target (type: dr_auxiliary, address: ip-address). date-and-time [node- name:iscsi.session.stateChanged:notice]: iSCSI session state is changed to Connected for the target iSCSI-target (type: dr_partner, address: ip-address). </pre> <p>d. Select the <b>Update flash from backup config</b> (sync flash) option from the displayed menu.</p> <p>If you are prompted to continue with the update, press <code>y</code>.</p>

4. Ensure that the environmental variables are set as expected:

- a. Take the controller to the `LOADER` prompt.
- b. Check the environment variable settings with the `printenv` command.
- c. If an environment variable is not set as expected, modify it with the `setenv environment_variable_name changed_value` command.
- d. Save your changes using the `saveenv` command.

5. The next depends on your system configuration:

- If your system has onboard keymanager, NSE or NVE configured, go to [Restore OKM, NSE, and NVE as needed](#)

- If your system does not have onboard keymanager, NSE or NVE configured, complete the steps in this section.

6. From the LOADER prompt, enter the `boot_ontap` command.

If you see...	Then...
The login prompt	Go to the next Step.
Waiting for giveback...	<ol style="list-style-type: none"> <li>Log into the partner controller.</li> <li>Confirm the target controller is ready for giveback with the <code>storage failover show</code> command.</li> </ol>

- Connect the console cable to the partner controller.
- Give back the controller using the `storage failover giveback -fromnode local` command.
- At the cluster prompt, check the logical interfaces with the `net int -is-home false` command.

If any interfaces are listed as "false", revert those interfaces back to their home port using the `net int revert` command.

- Move the console cable to the repaired controller and run the `version -v` command to check the ONTAP versions.
- Restore automatic giveback if you disabled it by using the `storage failover modify -node local -auto-giveback true` command.

### Restore OKM, NSE, and NVE as needed - ASA C250

Once environment variables are checked, you must complete steps specific to systems that have Onboard Key Manager (OKM), NetApp Storage Encryption (NSE) or NetApp Volume Encryption (NVE) enabled.

- Determine which section you should use to restore your OKM, NSE, or NVE configurations: If NSE or NVE are enabled along with Onboard Key Manager you must restore settings you captured at the beginning of this procedure.
  - If NSE or NVE are enabled and Onboard Key Manager is enabled, go to [Restore NVE or NSE when Onboard Key Manager is enabled](#).
  - If NSE or NVE are enabled for ONTAP 9.6, go to [Restore NSE/NVE on systems running ONTAP 9.6 and later](#).

### Restore NVE or NSE when Onboard Key Manager is enabled

#### Steps

- Connect the console cable to the target controller.
- Use the `boot_ontap` command at the LOADER prompt to boot the controller.
- Check the console output:

If the console displays...	Then...
The LOADER prompt	Boot the controller to the boot menu: <code>boot_ontap menu</code>
Waiting for giveback....	<ol style="list-style-type: none"> <li>Enter <code>Ctrl-C</code> at the prompt</li> <li>At the message: Do you wish to halt this node rather than wait [y/n]? , enter: <code>y</code></li> <li>At the LOADER prompt, enter the <code>boot_ontap menu</code> command.</li> </ol>

- At the Boot Menu, enter the hidden command, `recover_onboard_keymanager` and reply `y` at the prompt
- Enter the passphrase for the onboard key manager you obtained from the customer at the beginning of this procedure.
- When prompted to enter the backup data, paste the backup data you captured at the beginning of this procedure, when asked. Paste the output of `security key-manager backup show` OR `security key-manager onboard show-backup` command



The data is output from either `security key-manager backup show` or `security key-manager onboard show-backup` command.

Example of backup data:

```

-----BEGIN BACKUP-----
TmV0QXBwIEtleSBCbG9iAAEAAAAEAAAAcAEAAAAAADuD+byAAAAACEAAAAAAAAA
QAAAAAAAAABvOIH0AAAAAMh7qDLRyH1DBz12piVdy9ATSFMT0C0TIYFss4PDjTaV
dzRYkLd1PhQLxAWJwOlyqSr8qY1SEBgm1IWgE5DLRqkiAAAAAAAAACgAAAAAAAA
3WTh7gAAAAAAAAAAAAAAAAAIAAAAAAAgAZJEIWvdeHr5RCAvHGclo+wAAAAAAAAA
lgAAAAAAAAAoAAAAAAAAAEOTcR0AAAAAAAAAAAAAAAAACAAAAAAAAJAGr3tJA/
LRzUQRHwv+1aWvAAAAAAAAAACQAAAAAAAAAgAAAAAAAAACdhTcvAAAAAJ1PXeBf
ml4NBsSyV1B4jc4A7cvWEFY6ILG6hc6tbKLAHZuvfQ4rlbYAAAAAAAAAAAAAAAAA
AAAAAAAAAAAAAAAAAAAAAAAAAAAAAAAAAAAAAAAAAAAAAAAAAAAAAAAAAAAAAAAA
AAAAAAAAAAAAAAAAAAAAAAAAAAAAAAAAAAAAAAAAAAAAAAAAAAAAAAAAAAAAAAAA
.
.
.
.
H4nPQM0nrDRYRa9SCv8AAAAAAAAAAAAAAAAAAAAAAAAAAAAAAAAAAAAAAAAAAAAA
AAAAAAAAAAAAAAAAAAAAAAAAAAAAAAAAAAAAAAAAAAAAAAAAAAAAAAAAAAAAAAAA
AAAAAAAA
-----END BACKUP-----

```

- At the Boot Menu select the option for Normal Boot.  
The system boots to Waiting for giveback... prompt.
- Confirm the target controller is ready for giveback with the `storage failover show` command.

9. Giveback only the CFO aggregates with the `storage failover giveback -fromnode local -only-cfo-aggregates true` command.
  - If the command fails because of a failed disk, physically disengage the failed disk, but leave the disk in the slot until a replacement is received.
  - If the command fails because of an open CIFS sessions, check with customer how to close out CIFS sessions.



Terminating CIFS can cause loss of data.

- If the command fails because the partner "not ready", wait 5 minutes for the NVMEMs to synchronize.
  - If the command fails because of an NDMP, SnapMirror, or SnapVault process, disable the process. See the appropriate Documentation Center for more information.
10. Once the giveback completes, check the failover and giveback status with the `storage failover show` and `storage failover show-giveback` commands.

Only the CFO aggregates (root aggregate and CFO style data aggregates) will be shown.

11. Move the console cable to the target controller.
  - a. If you are running ONTAP 9.6 or later, run the security key-manager onboard sync:
  - b. Run the `security key-manager onboard sync` command and then enter the passphrase when prompted.
  - c. Enter the `security key-manager key query` command to see a detailed view of all keys stored in the onboard key manager and verify that the `Restored` column = `yes/true` for all authentication keys.



If the `Restored` column = anything other than `yes/true`, contact Customer Support.

- d. Wait 10 minutes for the key to synchronize across the cluster.
12. Move the console cable to the partner controller.
13. Give back the target controller using the `storage failover giveback -fromnode local` command.
14. Check the giveback status, 3 minutes after it reports complete, using the `storage failover show` command.

If giveback is not complete after 20 minutes, contact Customer Support.

15. At the clustershell prompt, enter the `net int show -is-home false` command to list the logical interfaces that are not on their home controller and port.

If any interfaces are listed as `false`, revert those interfaces back to their home port using the `net int revert -vserver Cluster -lif nodename` command.

16. Move the console cable to the target controller and run the `version -v` command to check the ONTAP versions.
17. Restore automatic giveback if you disabled it by using the `storage failover modify -node local -auto-giveback true` command.

## Restore NSE/NVE on systems running ONTAP 9.6 and later

### Steps

1. Connect the console cable to the target controller.
2. Use the `boot_ontap` command at the LOADER prompt to boot the controller.
3. Check the console output:

If the console displays...	Then...
The login prompt	Go to Step 7.
Waiting for giveback...	<ol style="list-style-type: none"><li>a. Log into the partner controller.</li><li>b. Confirm the target controller is ready for giveback with the <code>storage failover show</code> command.</li></ol>

4. Move the console cable to the partner controller and give back the target controller storage using the `storage failover giveback -fromnode local -only-cfo-aggregates true local` command.
  - If the command fails because of a failed disk, physically disengage the failed disk, but leave the disk in the slot until a replacement is received.
  - If the command fails because of an open CIFS sessions, check with customer how to close out CIFS sessions.



Terminating CIFS can cause loss of data.

- If the command fails because the partner "not ready", wait 5 minutes for the NVMEMs to synchronize.
  - If the command fails because of an NDMP, SnapMirror, or SnapVault process, disable the process. See the appropriate Documentation Center for more information.
5. Wait 3 minutes and check the failover status with the `storage failover show` command.
  6. At the clustershell prompt, enter the `net int show -is-home false` command to list the logical interfaces that are not on their home controller and port.

If any interfaces are listed as `false`, revert those interfaces back to their home port using the `net int revert -vserver Cluster -lif nodename` command.
  7. Move the console cable to the target controller and run the `version -v` command to check the ONTAP versions.
  8. Restore automatic giveback if you disabled it by using the `storage failover modify -node local -auto-giveback true` command.
  9. Use the `storage encryption disk show` at the clustershell prompt, to review the output.
  10. Use the `security key-manager key query` command to display the key IDs of the authentication keys that are stored on the key management servers.
    - If the `Restored` column = `yes/true`, you are done and can proceed to complete the replacement process.

- If the `Key Manager type = external` and the `Restored` column = anything other than `yes/true`, use the `security key-manager external restore` command to restore the key IDs of the authentication keys.



If the command fails, contact Customer Support.

- If the `Key Manager type = onboard` and the `Restored` column = anything other than `yes/true`, use the `security key-manager onboard sync` command to re-sync the Key Manager type.

Use the `security key-manager key query` command to verify that the `Restored` column = `yes/true` for all authentication keys.

11. Connect the console cable to the partner controller.
12. Give back the controller using the `storage failover giveback -fromnode local` command.
13. Restore automatic giveback if you disabled it by using the `storage failover modify -node local -auto-giveback true` command.

### Return the failed part to NetApp - ASA C250

Return the failed part to NetApp, as described in the RMA instructions shipped with the kit. See the [Part Return and Replacements](#) page for further information.

### Chassis

#### Overview of chassis replacement - ASA C250

To replace the chassis, you must move the bezel, controller modules, and NVMe drives from the impaired chassis to the replacement chassis, and then remove the impaired chassis from the equipment rack or system cabinet and install the replacement chassis in its place.

#### About this task

- All other components in the system must be functioning properly; if not, you must contact technical support.
- You can use this procedure with all versions of ONTAP supported by your system.
- This procedure is written with the assumption that you are moving the bezel, NVMe drives, and controller modules to the new chassis, and that the replacement chassis is a new component from NetApp.
- This procedure is disruptive. For a two-node cluster, you will have a complete service outage and a partial outage in a multi-node cluster.

#### Shut down the controllers - ASA C250

This procedure is for 2-node, non-MetroCluster configurations only. If you have a system with more than two nodes, see [How to perform a graceful shutdown and power up of one HA pair in a 4-node cluster](#).

#### Before you begin

You need:

- Local administrator credentials for ONTAP.
- NetApp onboard key management (OKM) cluster-wide passphrase if using storage encryption or NVE/NAE.
- BMC accessibility for each controller.
- Stop all clients/host from accessing data on the NetApp system.
- Suspend external backup jobs.
- Necessary tools and equipment for the replacement.



If the system is a NetApp StorageGRID or ONTAP S3 used as FabricPool cloud tier, refer to the [Gracefully shutdown and power up your storage system Resolution Guide](#) after performing this procedure.



If using SSDs, refer to [SU490: \(Impact: Critical\) SSD Best Practices: Avoid risk of drive failure and data loss if powered off for more than two months](#)

As a best practice before shutdown, you should:

- Perform additional [system health checks](#).
- Upgrade ONTAP to a recommended release for the system.
- Resolve any [Active IQ Wellness Alerts and Risks](#).  
Make note of any faults presently on the system, such as LEDs on the system components.

### Steps

1. Log into the cluster through SSH or log in from any node in the cluster using a local console cable and a laptop/console.
2. Turn off AutoSupport and indicate how long you expect the system to be offline:

```
system node autosupport invoke -node * -type all -message "MAINT=8h Power Maintenance"
```

3. Identify the SP/BMC address of all nodes:

```
system service-processor show -node * -fields address
```

4. Exit the cluster shell: `exit`
5. Log into SP/BMC over SSH using the IP address of any of the nodes listed in the output from the previous step.

If you're using a console/laptop, log into the controller using the same cluster administrator credentials.



Open an SSH session to every SP/BMC connection so that you can monitor progress.

6. Halt the 2 nodes located in the impaired chassis:

```
system node halt -node <node>,<node2> -skip-lif-migration-before-shutdown true -ignore-quorum-warnings true -inhibit-takeover true
```



For clusters using SnapMirror synchronous operating in StrictSync mode: `system node halt -node <node>, <node2> -skip-lif-migration-before-shutdown true -ignore-quorum-warnings true -inhibit-takeover true -ignore-strict-sync-warnings true`

7. Enter **y** for each controller in the cluster when you see *Warning: Are you sure you want to halt node "cluster <node-name> number"?*  
{y|n}:
8. Wait for each controller to halt and display the LOADER prompt.

## Replace hardware - ASA C250

To replace the chassis, you move the power supplies, hard drives, and controller module from the impaired chassis to the new chassis, and swap out the impaired chassis from with the new chassis of the same model as the impaired chassis.

### Step 1: Remove the controller modules

To replace the chassis, you must remove the controller modules from the old chassis.

Use the following video or the tabulated steps to replace the chassis; it assumes the removal and replacement of the bezel:

#### [Animation - Replace the chassis](#)

1. If you are not already grounded, properly ground yourself.
2. Unplug the controller module power supplies from the source.
3. Release the power cable retainers, and then unplug the cables from the power supplies.
4. Insert your forefinger into the latching mechanism on either side of the controller module, press the lever with your thumb, and gently pull the controller a few inches out of the chassis.



If you have difficulty removing the controller module, place your index fingers through the finger holes from the inside (by crossing your arms).

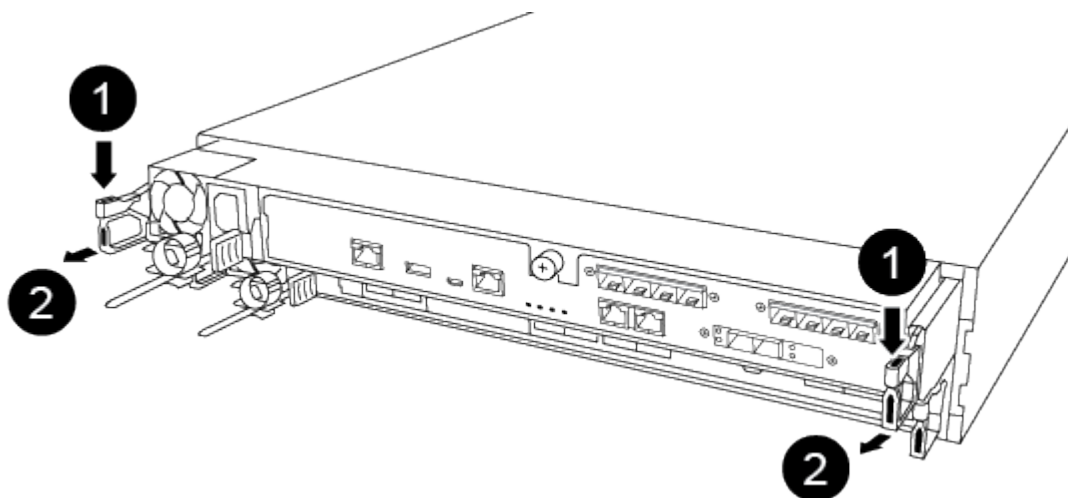



<b>1</b>	Lever
<b>2</b>	Latching mechanism

5. Using both hands, grasp the controller module sides and gently pull it out of the chassis and set it on a flat, stable surface.
6. Set the controller module aside in a safe place, and repeat these steps for the other controller module in the chassis.

## Step 2: Move drives to the new chassis

You need to move the drives from each bay opening in the old chassis to the same bay opening in the new chassis.

1. Gently remove the bezel from the front of the system.
2. Remove the drives:
  - a. Press the release button at the top of the carrier face below the LEDs.
  - b. Pull the cam handle to its fully open position to unseat the drive from the midplane, and then gently slide the drive out of the chassis.

The drive should disengage from the chassis, allowing it to slide free of the chassis.



When removing a drive, always use two hands to support its weight.



Drives are fragile. Handle them as little as possible to prevent damage to them.

3. Align the drive from the old chassis with the same bay opening in the new chassis.
4. Gently push the drive into the chassis as far as it will go.

The cam handle engages and begins to rotate upward.

5. Firmly push the drive the rest of the way into the chassis, and then lock the cam handle by pushing it up and against the drive holder.

Be sure to close the cam handle slowly so that it aligns correctly with the front of the drive carrier. It clicks when it is secure.

6. Repeat the process for the remaining drives in the system.

## Step 3: Replace a chassis from within the equipment rack or system cabinet

You must remove the existing chassis from the equipment rack or system cabinet before you can install the replacement chassis.

1. Remove the screws from the chassis mount points.
2. With two people, slide the old chassis off the rack rails in a system cabinet or equipment rack, and then set it aside.

3. If you are not already grounded, properly ground yourself.
4. Using two people, install the replacement chassis into the equipment rack or system cabinet by guiding the chassis onto the rack rails in a system cabinet or equipment rack.
5. Slide the chassis all the way into the equipment rack or system cabinet.
6. Secure the front of the chassis to the equipment rack or system cabinet, using the screws you removed from the old chassis.
7. If you have not already done so, install the bezel.

#### Step 4: Install the controller modules

After you install the controller modules into the new chassis, you need to boot the system.

For HA pairs with two controller modules in the same chassis, the sequence in which you install the controller module is especially important because it attempts to reboot as soon as you completely seat it in the chassis.

1. Align the end of the controller module with the opening in the chassis, and then gently push the controller module halfway into the system.



Do not completely insert the controller module in the chassis until instructed to do so.

2. Recable the console to the controller module, and then reconnect the management port.
3. Plug the power cables into the power supplies and reinstall the power cable retainers.
4. Insert the controller module into the chassis:
  - a. Ensure the latching mechanism arms are locked in the fully extended position.
  - b. Using both hands, align and gently slide the controller module into the latching mechanism arms until it stops.
  - c. Place your index fingers through the finger holes from the inside of the latching mechanism.
  - d. Press your thumbs down on the orange tabs on top of the latching mechanism and gently push the controller module over the stop.
  - e. Release your thumbs from the top of the latching mechanisms and continue pushing until the latching mechanisms snap into place.

The controller module begins to boot as soon as it is fully seated in the chassis. Be prepared to interrupt the boot process.

The controller module should be fully inserted and flush with the edges of the chassis.

5. Repeat the preceding steps to install the second controller into the new chassis.

#### Complete the restoration and replacement process - ASA C250

You must verify the HA state of the chassis, and return the failed part to NetApp, as described in the RMA instructions shipped with the kit.

#### Step 1: Verify and set the HA state of the chassis

You must verify the HA state of the chassis, and, if necessary, update the state to match your system configuration.

1. In Maintenance mode, from either controller module, display the HA state of the local controller module and chassis: `ha-config show`

The HA state should be the same for all components.

2. If the displayed system state for the chassis does not match your system configuration:

- a. Set the HA state for the chassis: `ha-config modify chassis HA-state`

The value for HA-state can be one of the following:

- `ha`
- `mcc`
- `mccip`
- `non-ha`

- b. Confirm that the setting has changed: `ha-config show`

3. If you have not already done so, recable the rest of your system.
4. Reinstall the bezel on the front of the system.

## Step 2: Return the failed part to NetApp

Return the failed part to NetApp, as described in the RMA instructions shipped with the kit. See the [Part Return and Replacements](#) page for further information.

### Controller

#### Overview of controller module replacement- ASA C250

You must review the prerequisites for the replacement procedure and select the correct one for your version of the ONTAP operating system.

- All drive shelves must be working properly.
- If your system is in a MetroCluster configuration, you must review the section [Choosing the correct recovery procedure](#) to determine whether you should use this procedure.
- You must replace the failed component with a replacement FRU component you received from your provider.
- You must be replacing a controller module with a controller module of the same model type. You cannot upgrade your system by just replacing the controller module.
- You cannot change any drives or drive shelves as part of this procedure.
- In this procedure, the boot device is moved from the impaired controller to the *replacement* controller so that the *replacement* controller will boot up in the same version of ONTAP as the old controller module.
- It is important that you apply the commands in these steps on the correct systems:
  - The *impaired* controller is the controller that is being replaced.
  - The *replacement* controller is the new controller that is replacing the impaired controller.
  - The *healthy* controller is the surviving controller.
- You must always capture the controller's console output to a text file.

This provides you a record of the procedure so that you can troubleshoot any issues that you might encounter during the replacement process.

## Shut down the impaired controller module - ASA C250

To shut down the impaired controller, you must determine the status of the controller and, if necessary, take over the controller so that the healthy controller continues to serve data from the impaired controller storage.

### About this task

- If you have a SAN system, you must have checked event messages (`cluster kernel-service show`) for the impaired controller SCSI blade. The `cluster kernel-service show` command (from `priv advanced` mode) displays the node name, quorum status of that node, availability status of that node, and operational status of that node.

Each SCSI-blade process should be in quorum with the other nodes in the cluster. Any issues must be resolved before you proceed with the replacement.

- If you have a cluster with more than two nodes, it must be in quorum. If the cluster is not in quorum or a healthy controller shows false for eligibility and health, you must correct the issue before shutting down the impaired controller; see [Synchronize a node with the cluster](#).

### Steps

1. If AutoSupport is enabled, suppress automatic case creation by invoking an AutoSupport message:  
`system node autosupport invoke -node * -type all -message MAINT=<# of hours>h`

The following AutoSupport message suppresses automatic case creation for two hours: `cluster1:> system node autosupport invoke -node * -type all -message MAINT=2h`

2. Disable automatic giveback from the console of the healthy controller: `storage failover modify -node local -auto-giveback false`



When you see *Do you want to disable auto-giveback?*, enter *y*.

3. Take the impaired controller to the LOADER prompt:

If the impaired controller is displaying...	Then...
The LOADER prompt	Go to the next step.
Waiting for giveback...	Press Ctrl-C, and then respond <i>y</i> when prompted.
System prompt or password prompt	Take over or halt the impaired controller from the healthy controller: <code>storage failover takeover -ofnode impaired_node_name</code>  When the impaired controller shows Waiting for giveback..., press Ctrl-C, and then respond <i>y</i> .

## Replace the controller module hardware - ASA C250

To replace the controller module hardware, you must remove the impaired controller, move FRU components to the replacement controller module, install the replacement controller module in the chassis, and then boot the system to Maintenance mode.

### Step 1: Remove the controller module

You must remove the controller module from the chassis when you replace a component inside the controller module.

Make sure that you label the cables so that you know where they came from.

Use the following video or the tabulated steps to replace a controller module:

#### [Animation - Replace a controller module](#)

1. If you are not already grounded, properly ground yourself.
2. Unplug the controller module power supplies from the source.
3. Release the power cable retainers, and then unplug the cables from the power supplies.
4. Insert your forefinger into the latching mechanism on either side of the controller module, press the lever with your thumb, and gently pull the controller a few inches out of the chassis.



If you have difficulty removing the controller module, place your index fingers through the finger holes from the inside (by crossing your arms).

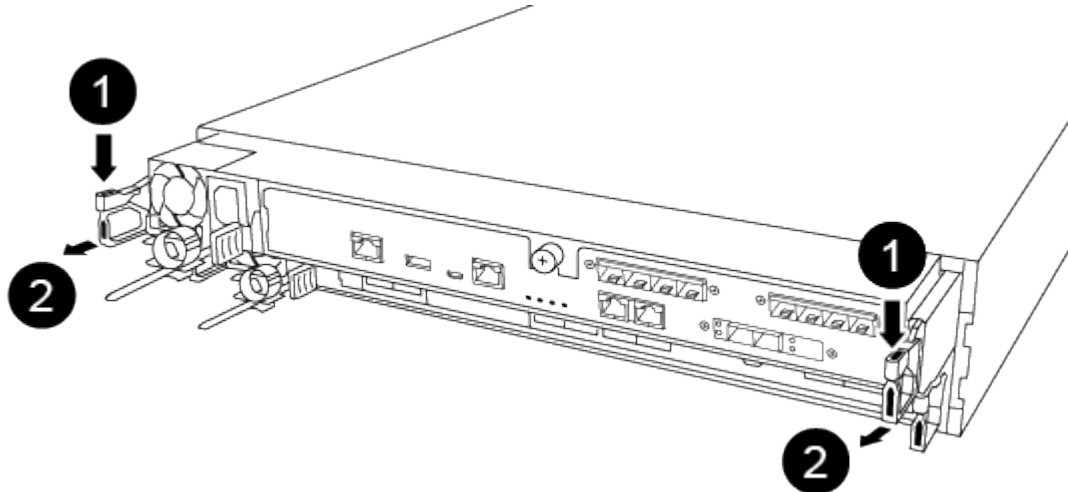

<b>1</b>	Lever
<b>2</b>	Latching mechanism

5. Using both hands, grasp the controller module sides and gently pull it out of the chassis and set it on a flat, stable surface.
6. Turn the thumbscrew on the front of the controller module anti-clockwise and open the controller module

cover.

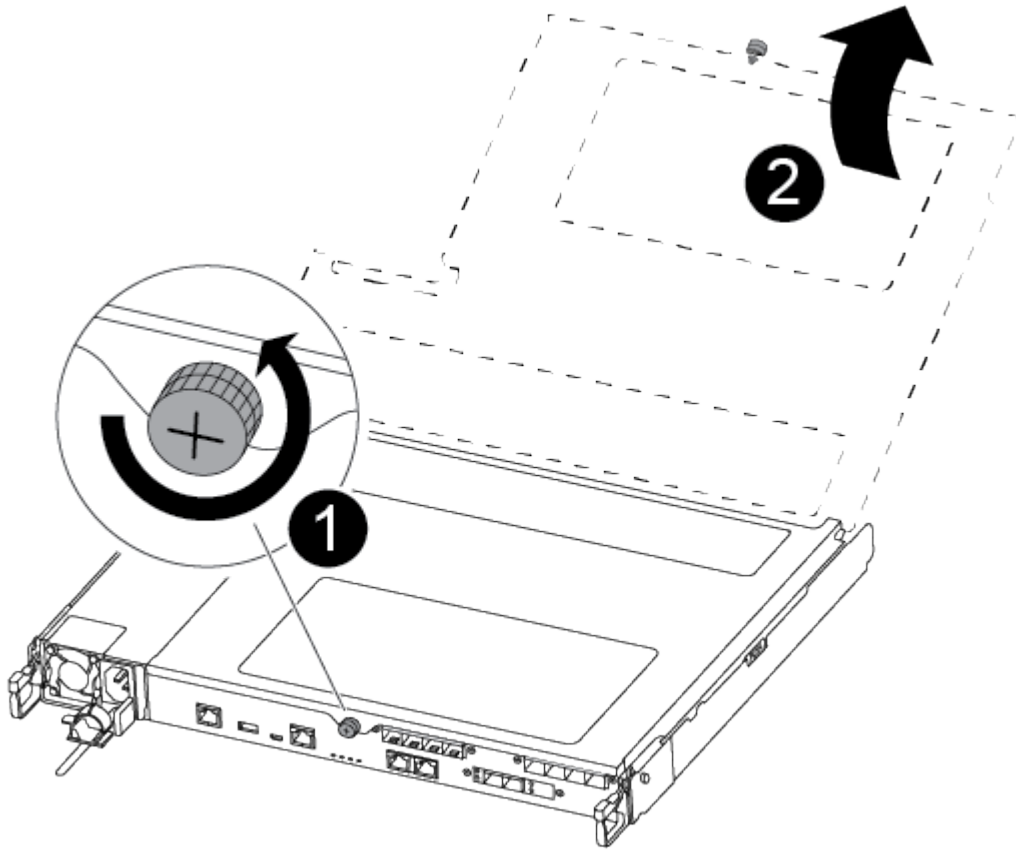

1	Thumbscrew
2	Controller module cover.

7. Lift out the air duct cover.

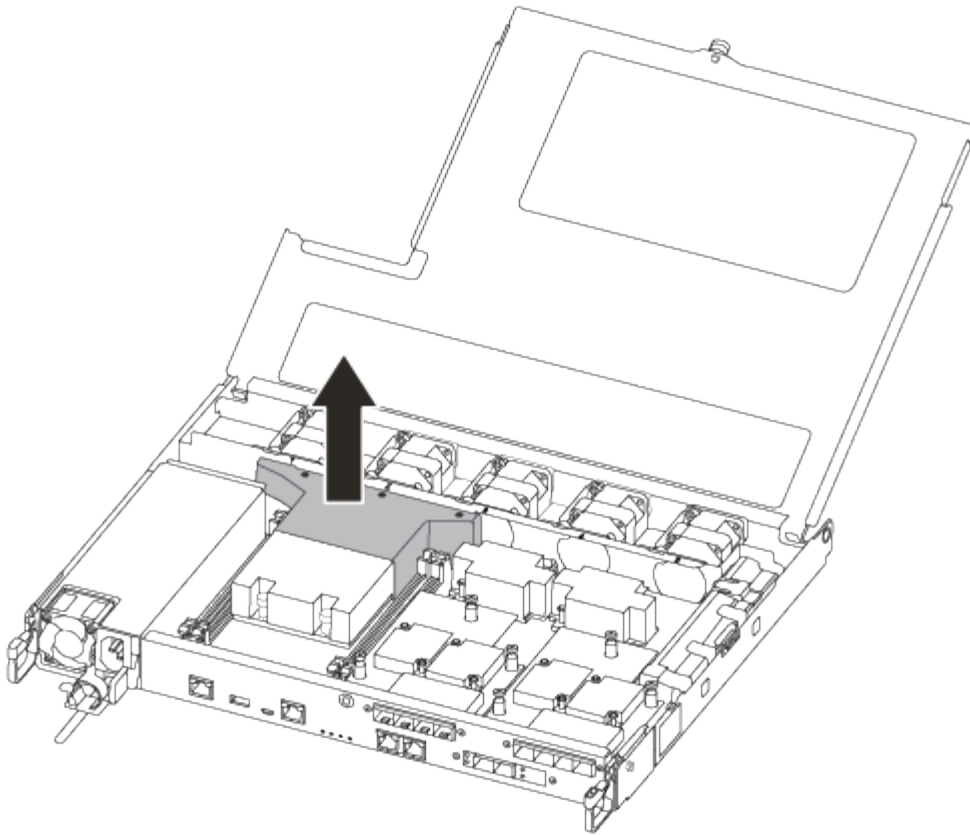

## Step 2: Move the power supply

You must move the power supply from the impaired controller module to the replacement controller module when you replace a controller module.

1. Disconnect the power supply.
2. Open the power cable retainer, and then unplug the power cable from the power supply.
3. Unplug the power cable from the power source.
4. Rotate the cam handle such that it can be used to pull power supply out of the controller module while pressing the locking tab.



Do not use excessive force when sliding the controller module into the chassis to avoid damaging the connectors.

The power supply is short. Always use two hands to support it when removing it from the controller module so that it does not suddenly swing free from the controller module and injure you.

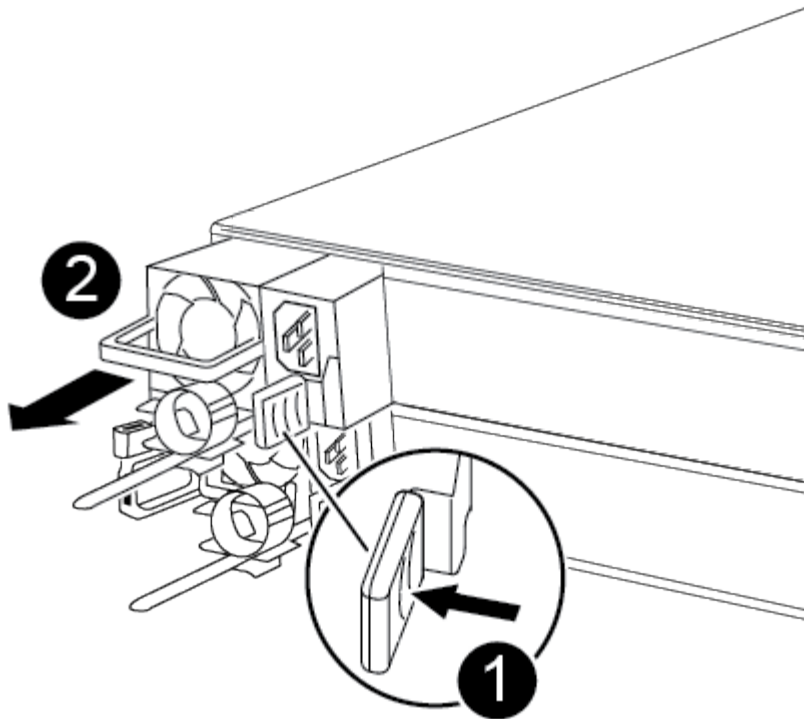

1	Blue power supply locking tab
2	Power supply

5. Move the power supply to the new controller module, and then install it.
6. Using both hands, support and align the edges of the power supply with the opening in the controller module, and then gently push the power supply into the controller module until the locking tab clicks into place.

The power supplies will only properly engage with the internal connector and lock in place one way.



To avoid damaging the internal connector, do not use excessive force when sliding the power supply into the system.

### Step 3: Move the fans

You must move the fans from the impaired controller module to the replacement module when replacing a failed controller module.

1. Remove the fan module by pinching the side of the fan module, and then lifting the fan module straight out of the controller module.



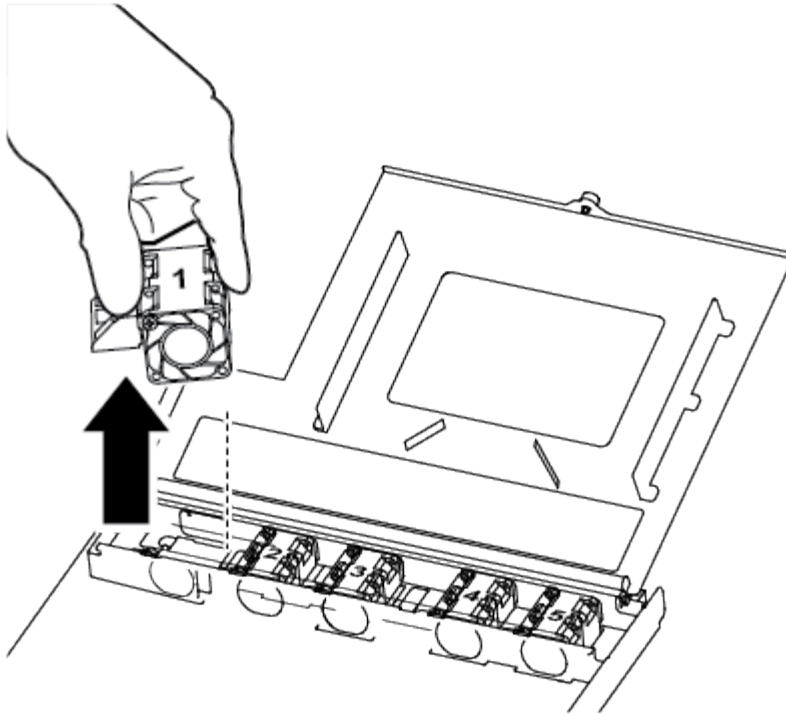

<b>1</b>	Fan module
----------	------------

2. Move the fan module to the replacement controller module, and align the edges of the fan module with the opening in the controller module, and then slide the fan module in.
3. Repeat these steps for the remaining fan modules.

#### Step 4: Move the boot media

You must move the boot media device from the impaired controller module to the replacement controller module.

You need a #1 magnetic Phillips head screwdriver to remove the screw that holds the boot media in place. Due to the space constraints within the controller module, you should also have a magnet to transfer the screw on to so that you do not lose it.

1. Locate and move the boot media from the impaired controller module to the replacement controller module.

The boot media is located under the air duct cover you removed earlier in this procedure.

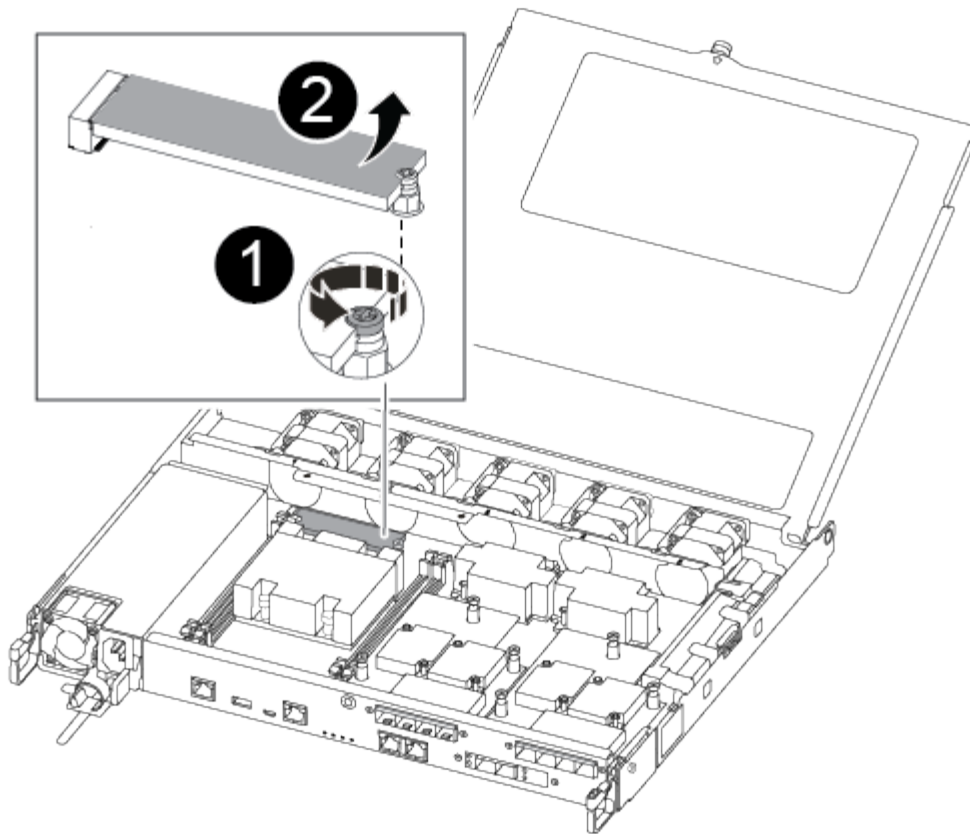

1	Remove the screw securing the boot media to the motherboard in the impaired controller module.
2	Lift the boot media out of the impaired controller module.

2. Using the #1 magnetic screwdriver, remove the screw from the boot media, and set it aside safely on the magnet.
3. Gently lift the boot media directly out of the socket and align it into place in the replacement controller module.
4. Using the #1 magnetic screwdriver, insert and tighten the screw on the boot media.



Do not apply force when tightening the screw on the boot media; you might crack it.

### Step 5: Move the DIMMs

To move the DIMMs, locate and move them from the impaired controller into the replacement controller and follow the specific sequence of steps.

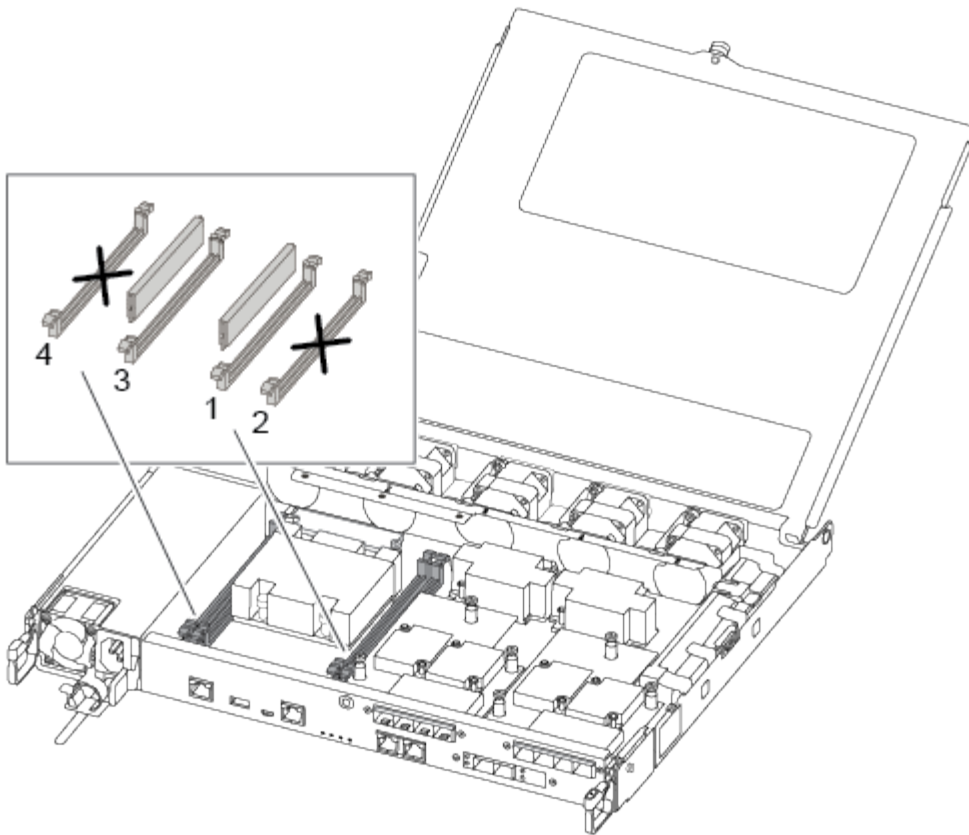

Install each DIMM into the same slot it occupied in the impaired controller module.

1. Slowly push apart the DIMM ejector tabs on either side of the DIMM, and slide the DIMM out of the slot.



Hold the DIMM by the edges to avoid pressure on the components on the DIMM circuit board.

2. Locate the corresponding DIMM slot on the replacement controller module.
3. Make sure that the DIMM ejector tabs on the DIMM socket are in the open position, and then insert the DIMM squarely into the socket.

The DIMMs fit tightly in the socket. If not, reinsert the DIMM to realign it with the socket.

4. Visually inspect the DIMM to verify that it is evenly aligned and fully inserted into the socket.
5. Repeat these steps for the remaining DIMM.

### Step 6: Move a mezzanine card

To move a mezzanine card, you must remove the cabling and any QSFPs and SFPs from the ports, move the mezzanine card to the replacement controller, reinstall any QSFPs and SFPs onto the ports, and cable the ports.

1. Locate and move the mezzanine cards from your impaired controller module.

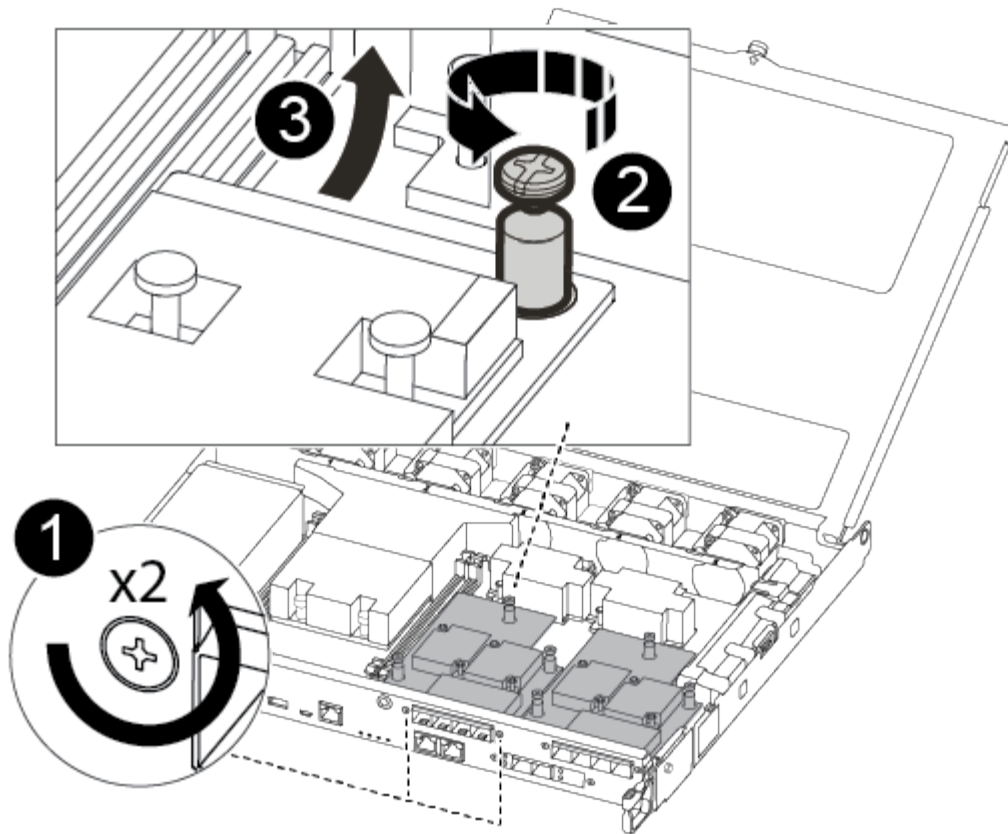

1	Remove screws on the face of the controller module.
2	Loosen the screw in the controller module.
3	Move the mezzanine card.

2. Unplug any cabling associated with the mezzanine card.

Make sure that you label the cables so that you know where they came from.

- a. Remove any SFP or QSFP modules that might be in the mezzanine card and set it aside.
- b. Using the #1 magnetic screwdriver, remove the screws from the face of the impaired controller module and from the mezzanine card, and set them aside safely on the magnet.
- c. Gently lift the mezzanine card out of the socket and move it to the same position in the replacement controller.
- d. Gently align the mezzanine card into place in the replacement controller.
- e. Using the #1 magnetic screwdriver, insert and tighten the screws on the face of the replacement controller module and on the mezzanine card.



Do not apply force when tightening the screw on the mezzanine card; you might crack it.

3. Repeat these steps if there is another mezzanine card in the impaired controller module.

4. Insert the SFP or QSFP modules that were removed onto the mezzanine card.

### Step 7: Move the NV battery

When replacing the controller module, you must move the NV battery from the impaired controller module to the replacement controller module.

1. Locate and move the NVMEM battery from your impaired controller module to the replacement controller module.

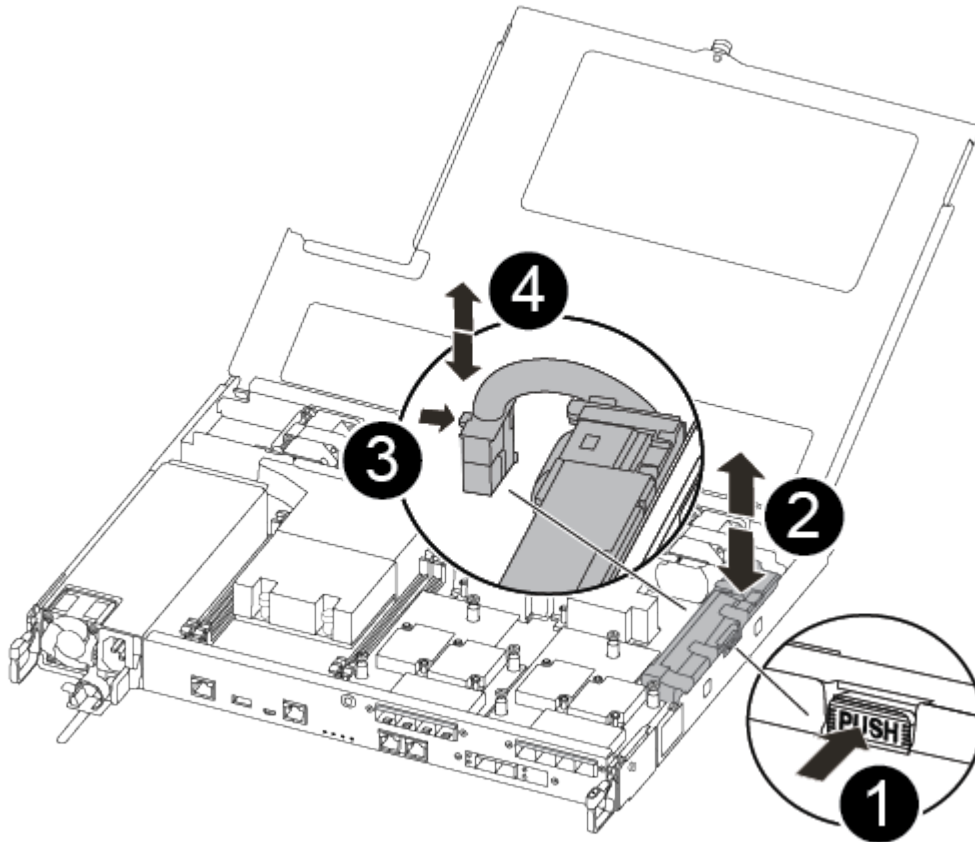

1	Squeeze the clip on the face of the battery plug.
2	Unplug the battery cable from the socket.
3	Grasp the battery and press the blue locking tab marked PUSH.
4	Lift the battery out of the holder and controller module.

2. Locate the battery plug and squeeze the clip on the face of the battery plug to release the plug from the socket.
3. Grasp the battery and press the blue locking tab marked PUSH, and then lift the battery out of the holder and controller module.

4. Locate the corresponding NV battery holder on the replacement controller module and align the NV battery to the battery holder.
5. Insert the NV battery plug into the socket.
6. Slide the battery pack down along the sheet metal side wall until the support tabs on the side wall hook into the slots on the battery pack, and the battery pack latch engages and clicks into the opening on the side wall.
7. Press firmly down on the battery pack to make sure that it is locked into place.

### Step 8: Install the controller module

After all of the components have been moved from the impaired controller module to the replacement controller module, you must install the replacement controller module into the chassis, and then boot it to Maintenance mode.

You can use the following illustrations or the written steps to install the replacement controller module in the chassis.

1. If you have not already done so, install the air duct.

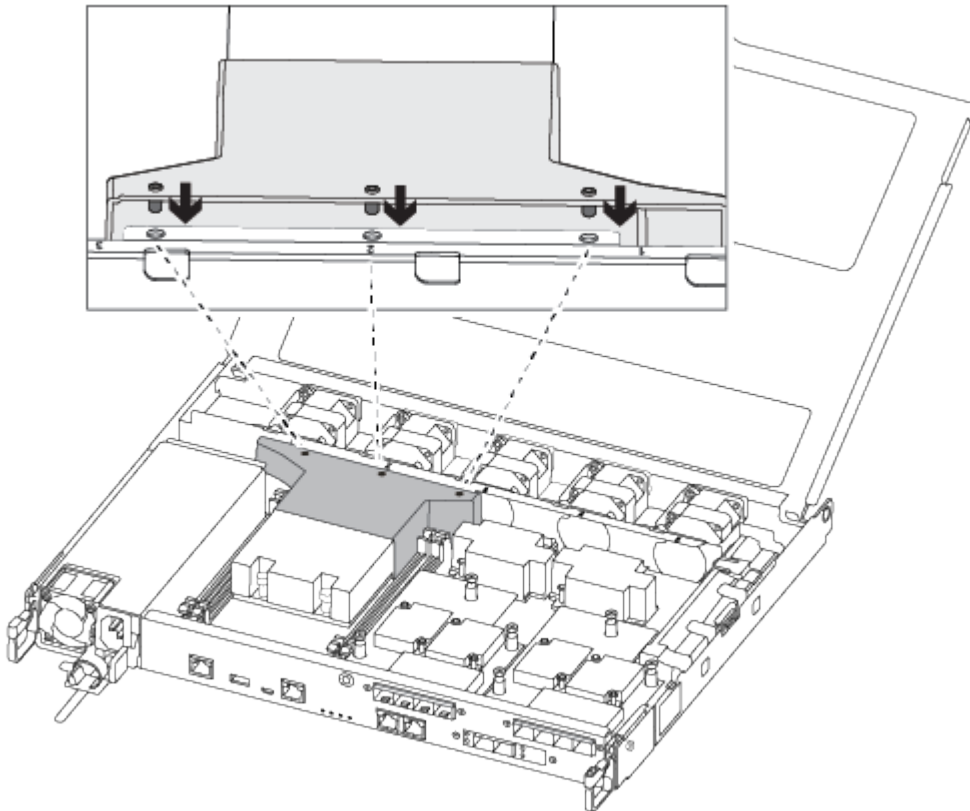

2. Close the controller module cover and tighten the thumbscrew.

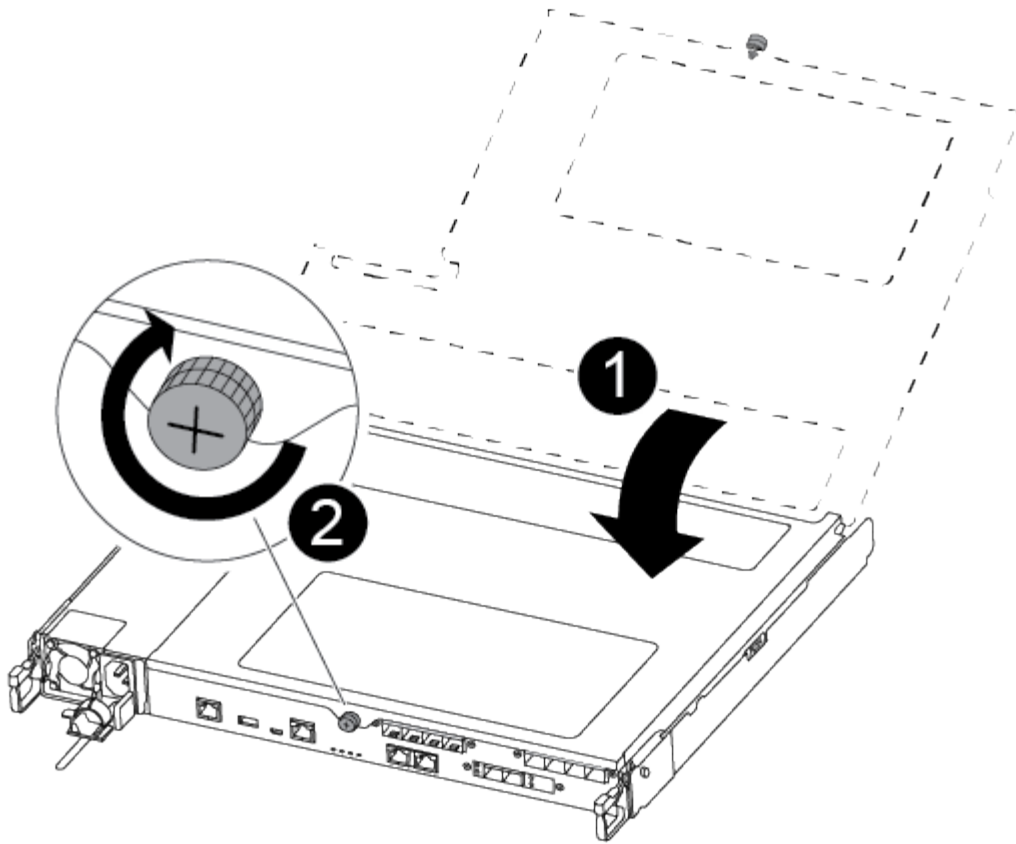

1	Controller module cover
2	Thumbscrew

3. Align the end of the controller module with the opening in the chassis, and then gently push the controller module halfway into the system.

 Do not completely insert the controller module in the chassis until instructed to do so.

4. Cable the management and console ports only, so that you can access the system to perform the tasks in the following sections.

 You will connect the rest of the cables to the controller module later in this procedure.

5. Insert the controller module into the chassis:

6. Ensure the latching mechanism arms are locked in the fully extended position.

7. Using both hands, align and gently slide the controller module into the latching mechanism arms until it stops.

8. Place your index fingers through the finger holes from the inside of the latching mechanism.

9. Press your thumbs down on the orange tabs on top of the latching mechanism and gently push the controller module over the stop.

10. Release your thumbs from the top of the latching mechanisms and continue pushing until the latching

mechanisms snap into place.

The controller module begins to boot as soon as it is fully seated in the chassis. Be prepared to interrupt the boot process.

The controller module should be fully inserted and flush with the edges of the chassis.

## Restore and verify the system configuration - ASA C250

After completing the hardware replacement and booting to Maintenance mode, you verify the low-level system configuration of the replacement controller and reconfigure system settings as necessary.

### Step 1: Set and verify system time after replacing the controller

You should check the time and date on the replacement controller module against the healthy controller module in an HA pair, or against a reliable time server in a stand-alone configuration. If the time and date do not match, you must reset them on the replacement controller module to prevent possible outages on clients due to time differences.

#### About this task

It is important that you apply the commands in the steps on the correct systems:

- The *replacement* node is the new node that replaced the impaired node as part of this procedure.
- The *healthy* node is the HA partner of the *replacement* node.

#### Steps

1. If the *replacement* node is not at the LOADER prompt, halt the system to the LOADER prompt.
2. On the *healthy* node, check the system time: `cluster date show`

The date and time are based on the configured timezone.

3. At the LOADER prompt, check the date and time on the *replacement* node: `show date`

The date and time are given in GMT.

4. If necessary, set the date in GMT on the replacement node: `set date mm/dd/yyyy`
5. If necessary, set the time in GMT on the replacement node: `set time hh:mm:ss`
6. At the LOADER prompt, confirm the date and time on the *replacement* node: `show date`

The date and time are given in GMT.

### Step 2: Verify and set the HA state of the controller

You must verify the HA state of the controller module and, if necessary, update the state to match your system configuration.

1. In Maintenance mode from the new controller module, verify that all components display the same HA state: `ha-config show`



The HA state should be the same for all components.

2. If the displayed system state of the controller module does not match your system configuration, set the HA state for the controller module: `ha-config modify controller ha-state`

The value for HA-state can be one of the following:

- ha
- mcc
- mccip
- non-ha

3. If the displayed system state of the controller module does not match your system configuration, set the HA state for the controller module: `ha-config modify controller ha-state`
4. Confirm that the setting has changed: `ha-config show`

## Recable the system and reassign disks - ASA C250

Continue the replacement procedure by recabling the storage and confirming disk reassignment.

### Step 1: Recable the system

Recable the controller module's storage and network connections.

#### Steps

1. Recable the the controller module to storage and network connections.
2. Verify that the cabling is correct by using [Active IQ Config Advisor](#).
  - a. Download and install Config Advisor.
  - b. Enter the information for the target system, and then click Collect Data.
  - c. Click the Cabling tab, and then examine the output. Make sure that all disk shelves are displayed and all disks appear in the output, correcting any cabling issues you find.
  - d. Check other cabling by clicking the appropriate tab, and then examining the output from Config Advisor.

### Step 2: Reassign disks

If the storage system is in an HA pair, the system ID of the new controller module is automatically assigned to the disks when the giveback occurs at the end of the procedure. You must confirm the system ID change when you boot the *replacement* controller and then verify that the change was implemented.

This procedure applies only to systems running ONTAP in an HA pair.

1. If the *replacement* controller is in Maintenance mode (showing the `*>` prompt, exit Maintenance mode and go to the LOADER prompt: `halt`
2. From the LOADER prompt on the *replacement* controller, boot the controller, entering `y` if you are prompted to override the system ID due to a system ID mismatch:
3. Wait until the `Waiting for giveback...` message is displayed on the *replacement* controller console and then, from the healthy controller, verify that the new partner system ID has been automatically assigned: `storage failover show`

In the command output, you should see a message that the system ID has changed on the impaired controller, showing the correct old and new IDs. In the following example, node2 has undergone replacement and has a new system ID of 151759706.

```
node1> `storage failover show`

Node                Partner                Takeover
-----                -----                -
node1                node2                false
partner (Old:
151759706), In takeover
node2                node1                -
(HA mailboxes)                Waiting for giveback
```

4. From the healthy controller, verify that any coredumps are saved:

a. Change to the advanced privilege level: `set -privilege advanced`

You can respond `y` when prompted to continue into advanced mode. The advanced mode prompt appears (`*>`).

b. Save any coredumps: `system node run -node local-node-name partner savecore`

c. Wait for the `savecore` command to complete before issuing the giveback.

You can enter the following command to monitor the progress of the `savecore` command: `system node run -node local-node-name partner savecore -s`

d. Return to the admin privilege level: `set -privilege admin`

5. If your storage system has Storage or Volume Encryption configured, you must restore Storage or Volume Encryption functionality by using one of the following procedures, depending on whether you are using onboard or external key management:

- [Restore onboard key management encryption keys](#)
- [Restore external key management encryption keys](#)

6. Give back the controller:

a. From the healthy controller, give back the replaced controller's storage: `storage failover giveback -ofnode replacement_node_name`

The *replacement* controller takes back its storage and completes booting.

If you are prompted to override the system ID due to a system ID mismatch, you should enter `y`.



If the giveback is vetoed, you can consider overriding the vetoes.

[Find the High-Availability Configuration content for your version of ONTAP 9](#)

- b. After the giveback has been completed, confirm that the HA pair is healthy and that takeover is possible: `storage failover show`

The output from the `storage failover show` command should not include the System ID changed on partner message.

7. Verify that the disks were assigned correctly: `storage disk show -ownership`

The disks belonging to the *replacement* controller should show the new system ID. In the following example, the disks owned by node1 now show the new system ID, 1873775277:

```
node1> `storage disk show -ownership`

Disk  Aggregate Home  Owner  DR Home  Home ID      Owner ID      DR Home ID
Reserver Pool
-----
-----
-----
1.0.0  aggr0_1  node1 node1  -        1873775277  1873775277  -
1873775277 Pool10
1.0.1  aggr0_1  node1 node1  -        1873775277  1873775277  -
1873775277 Pool10
.
.
.
```

8. If the system is in a MetroCluster configuration, monitor the status of the controller: `metrocluster node show`

The MetroCluster configuration takes a few minutes after the replacement to return to a normal state, at which time each controller will show a configured state, with DR Mirroring enabled and a mode of normal. The `metrocluster node show -fields node-systemid` command output displays the old system ID until the MetroCluster configuration returns to a normal state.

9. If the controller is in a MetroCluster configuration, depending on the MetroCluster state, verify that the DR home ID field shows the original owner of the disk if the original owner is a controller on the disaster site.

This is required if both of the following are true:

- The MetroCluster configuration is in a switchover state.
- The *replacement* controller is the current owner of the disks on the disaster site.

[Disk ownership changes during HA takeover and MetroCluster switchover in a four-node MetroCluster configuration](#)

10. If your system is in a MetroCluster configuration, verify that each controller is configured: `metrocluster node show - fields configuration-state`

```

node1_siteA::> metrocluster node show -fields configuration-state

dr-group-id          cluster node          configuration-state
-----
-----
1 node1_siteA        node1mcc-001         configured
1 node1_siteA        node1mcc-002         configured
1 node1_siteB        node1mcc-003         configured
1 node1_siteB        node1mcc-004         configured

4 entries were displayed.

```

11. Verify that the expected volumes are present for each controller: `vol show -node node-name`
12. If you disabled automatic takeover on reboot, enable it from the healthy controller: `storage failover modify -node replacement-node-name -onreboot true`

### Complete system restoration - ASA C250

To restore your system to full operation, you must restore the NetApp Storage Encryption configuration (if necessary), and install licenses for the new controller, and return the failed part to NetApp, as described in the RMA instructions shipped with the kit.

#### Step 1: Install licenses for the replacement controller in ONTAP

You must install new licenses for the *replacement* node if the impaired node was using ONTAP features that require a standard (node-locked) license. For features with standard licenses, each node in the cluster should have its own key for the feature.

#### About this task

Until you install license keys, features requiring standard licenses continue to be available to the *replacement* node. However, if the impaired node was the only node in the cluster with a license for the feature, no configuration changes to the feature are allowed. Also, using unlicensed features on the node might put you out of compliance with your license agreement, so you should install the replacement license key or keys on the *replacement* node as soon as possible.

#### Before you begin

The licenses keys must be in the 28-character format.

You have a 90-day grace period in which to install the license keys. After the grace period, all old licenses are invalidated. After a valid license key is installed, you have 24 hours to install all of the keys before the grace period ends.

#### Steps

1. If you need new license keys, obtain replacement license keys on the [NetApp Support Site](#) in the My Support section under Software licenses.



The new license keys that you require are automatically generated and sent to the email address on file. If you fail to receive the email with the license keys within 30 days, you should contact technical support.

2. Install each license key: `system license add -license-code license-key, license-key...`
3. Remove the old licenses, if desired:
  - a. Check for unused licenses: `license clean-up -unused -simulate`
  - b. If the list looks correct, remove the unused licenses: `license clean-up -unused`

## Step 2: Verify LIFs and registering the serial number

Before returning the *replacement* node to service, you should verify that the LIFs are on their home ports, and register the serial number of the *replacement* node if AutoSupport is enabled, and reset automatic giveback.

### Steps

1. Verify that the logical interfaces are reporting to their home server and ports: `network interface show -is-home false`  
  
If any LIFs are listed as false, revert them to their home ports: `network interface revert -vserver * -lif *`
2. Register the system serial number with NetApp Support.
  - If AutoSupport is enabled, send an AutoSupport message to register the serial number.
  - If AutoSupport is not enabled, call [NetApp Support](#) to register the serial number.
3. If an AutoSupport maintenance window was triggered, end it by using the `system node autosupport invoke -node * -type all -message MAINT=END` command.
4. If automatic giveback was disabled, reenable it: `storage failover modify -node local -auto-giveback true`

## Step 3: Return the failed part to NetApp

Return the failed part to NetApp, as described in the RMA instructions shipped with the kit. See the [Part Return and Replacements](#) page for further information.

### Replace a DIMM - ASA C250

You must replace a DIMM in the controller module when your system registers an increasing number of correctable error correction codes (ECC); failure to do so causes a system panic.

#### About this task

All other components in the system must be functioning properly; if not, you must contact technical support.

You must replace the failed component with a replacement FRU component you received from your provider.

## Step 1: Shut down the impaired controller

To shut down the impaired controller, you must determine the status of the controller and, if necessary, take

over the controller so that the healthy controller continues to serve data from the impaired controller storage.

### About this task

- If you have a SAN system, you must have checked event messages (`cluster kernel-service show`) for the impaired controller SCSI blade. The `cluster kernel-service show` command (from `priv advanced mode`) displays the node name, quorum status of that node, availability status of that node, and operational status of that node.

Each SCSI-blade process should be in quorum with the other nodes in the cluster. Any issues must be resolved before you proceed with the replacement.

- If you have a cluster with more than two nodes, it must be in quorum. If the cluster is not in quorum or a healthy controller shows `false` for eligibility and health, you must correct the issue before shutting down the impaired controller; see [Synchronize a node with the cluster](#).

### Steps

1. If AutoSupport is enabled, suppress automatic case creation by invoking an AutoSupport message:  
`system node autosupport invoke -node * -type all -message MAINT=<# of hours>h`

The following AutoSupport message suppresses automatic case creation for two hours: `cluster1:>`  
`system node autosupport invoke -node * -type all -message MAINT=2h`

2. Disable automatic giveback from the console of the healthy controller: `storage failover modify -node local -auto-giveback false`



When you see *Do you want to disable auto-giveback?*, enter `y`.

3. Take the impaired controller to the LOADER prompt:

If the impaired controller is displaying...	Then...
The LOADER prompt	Go to the next step.
Waiting for giveback...	Press Ctrl-C, and then respond <code>y</code> when prompted.
System prompt or password prompt	Take over or halt the impaired controller from the healthy controller: <code>storage failover takeover -ofnode impaired_node_name</code>  When the impaired controller shows <code>Waiting for giveback...</code> , press Ctrl-C, and then respond <code>y</code> .

### Step 2: Remove the controller module

You must remove the controller module from the chassis when you replace a component inside the controller module.

Make sure that you label the cables so that you know where they came from.

1. If you are not already grounded, properly ground yourself.

2. Unplug the controller module power supplies from the source.
3. Release the power cable retainers, and then unplug the cables from the power supplies.
4. Insert your forefinger into the latching mechanism on either side of the controller module, press the lever with your thumb, and gently pull the controller a few inches out of the chassis.



If you have difficulty removing the controller module, place your index fingers through the finger holes from the inside (by crossing your arms).

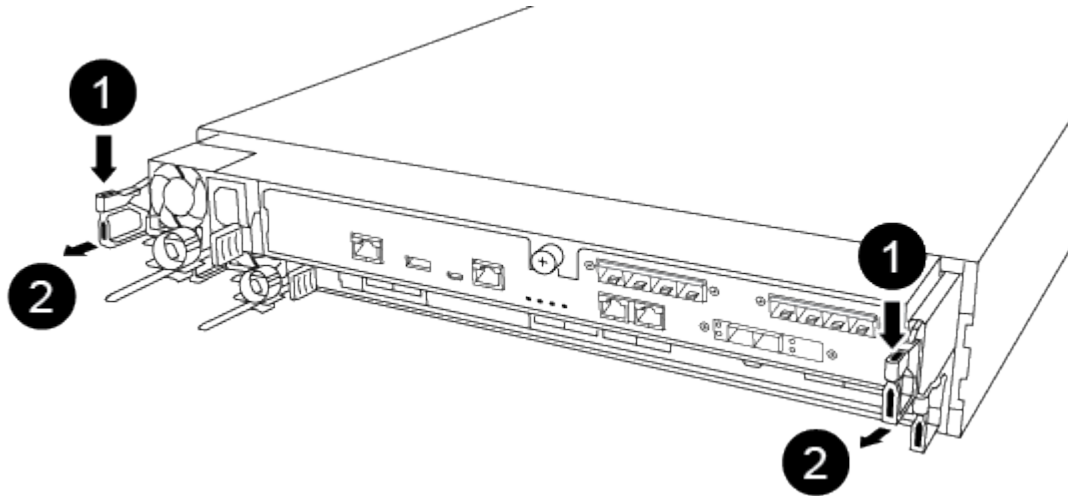

<b>1</b>	Lever
<b>2</b>	Latching mechanism

5. Using both hands, grasp the controller module sides and gently pull it out of the chassis and set it on a flat, stable surface.
6. Turn the thumbscrew on the front of the controller module anti-clockwise and open the controller module cover.

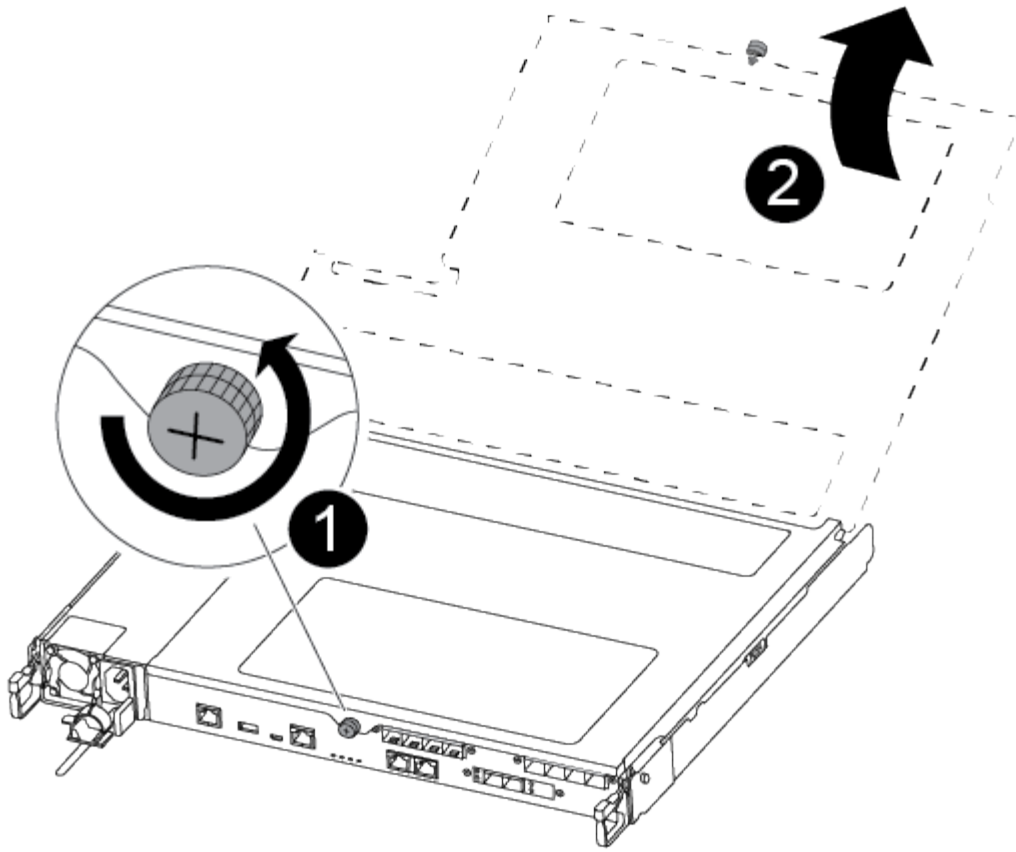

1	Thumbscrew
2	Controller module cover.

7. Lift out the air duct cover.



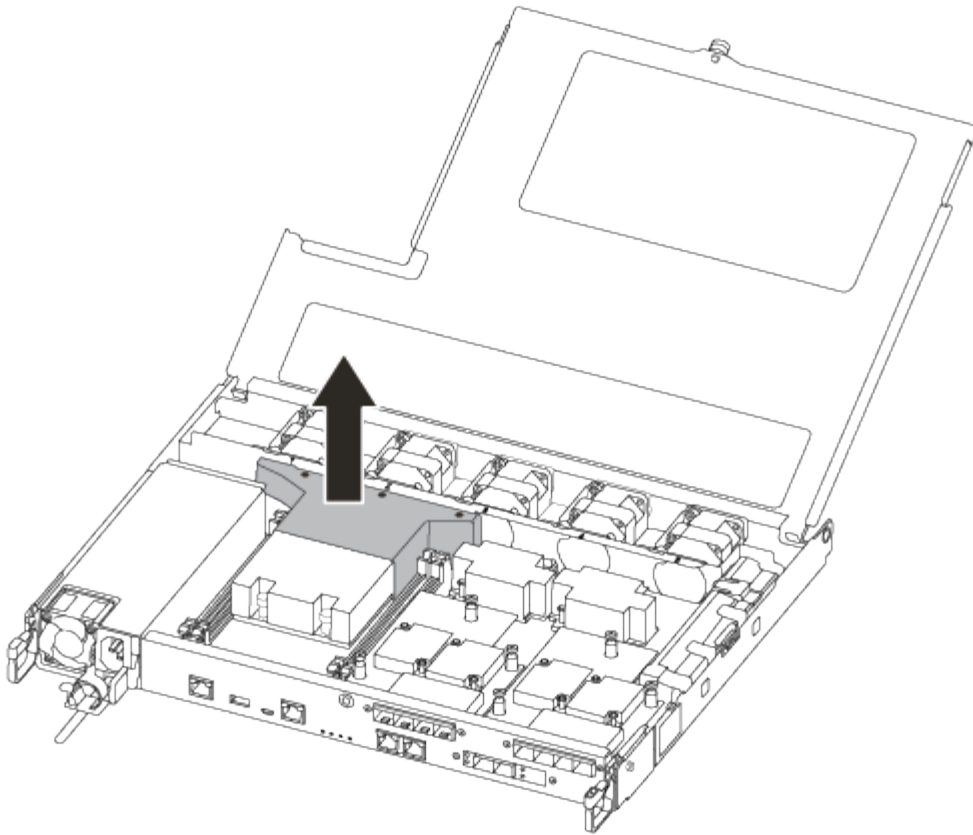

### Step 3: Replace a DIMM

To replace a DIMM, you must locate it in the controller module using the DIMM map label on top of the air duct and then replace it following the specific sequence of steps.

Use the following video or the tabulated steps to replace a DIMM:

[Animation - Replace a DIMM](#)

1. Replace the impaired DIMM on your controller module.

The DIMMs are in slot 3 or 1 on the motherboard. Slot 2 and 4 are left empty. Do not attempt to install DIMMs into these slots.

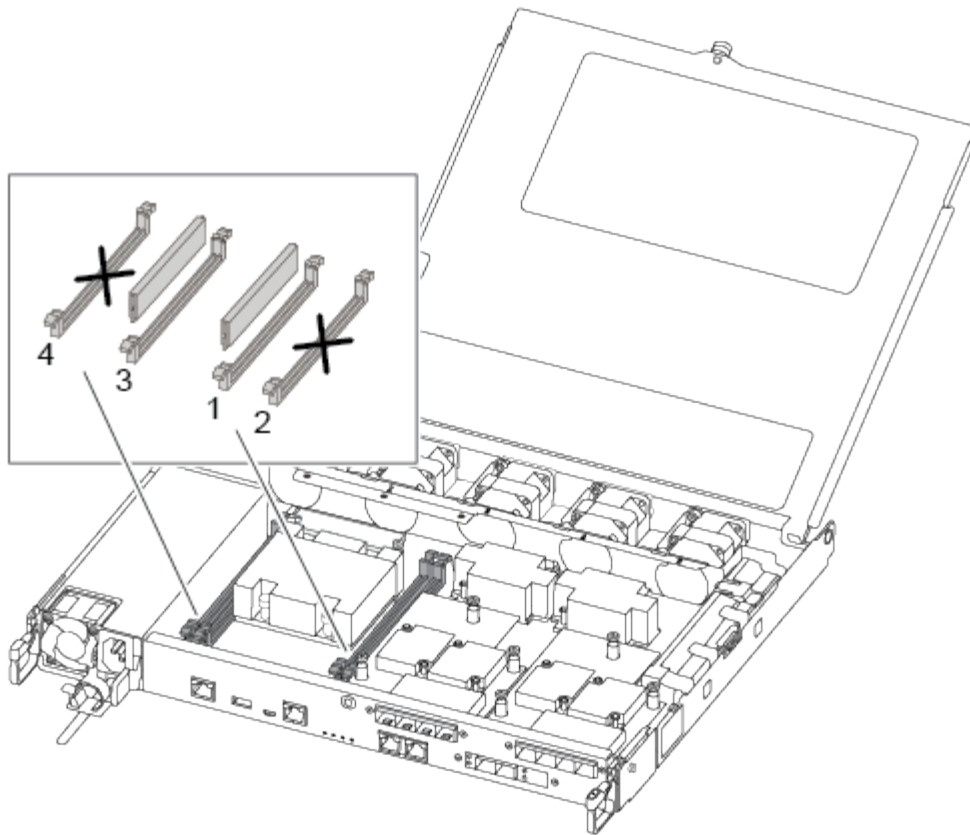

2. Note the orientation of the DIMM in the socket so that you can insert the replacement DIMM in the proper orientation.
3. Slowly push apart the DIMM ejector tabs on either side of the DIMM, and slide the DIMM out of the slot.
4. Leave DIMM ejector tabs on the connector in the open position.
5. Remove the replacement DIMM from the antistatic shipping bag, hold the DIMM by the corners, and align it to the slot.



Hold the DIMM by the edges to avoid pressure on the components on the DIMM circuit board.

6. Insert the replacement DIMM squarely into the slot.

The DIMMs fit tightly in the socket. If not, reinsert the DIMM to realign it with the socket.

7. Visually inspect the DIMM to verify that it is evenly aligned and fully inserted into the socket.

#### Step 4: Install the controller module

After you have replaced the component in the controller module, you must reinstall the controller module into the chassis, and then boot it.

You can use the following illustrations or the written steps to install the replacement controller module in the chassis.

1. If you have not already done so, install the air duct.

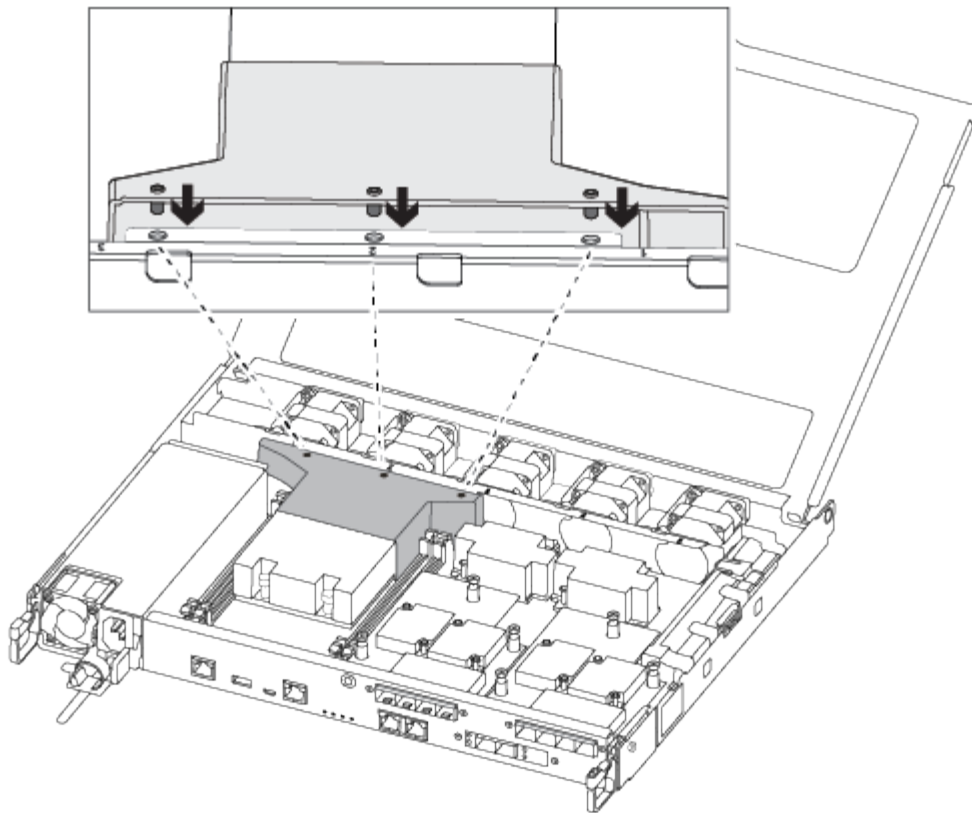

2. Close the controller module cover and tighten the thumbscrew.

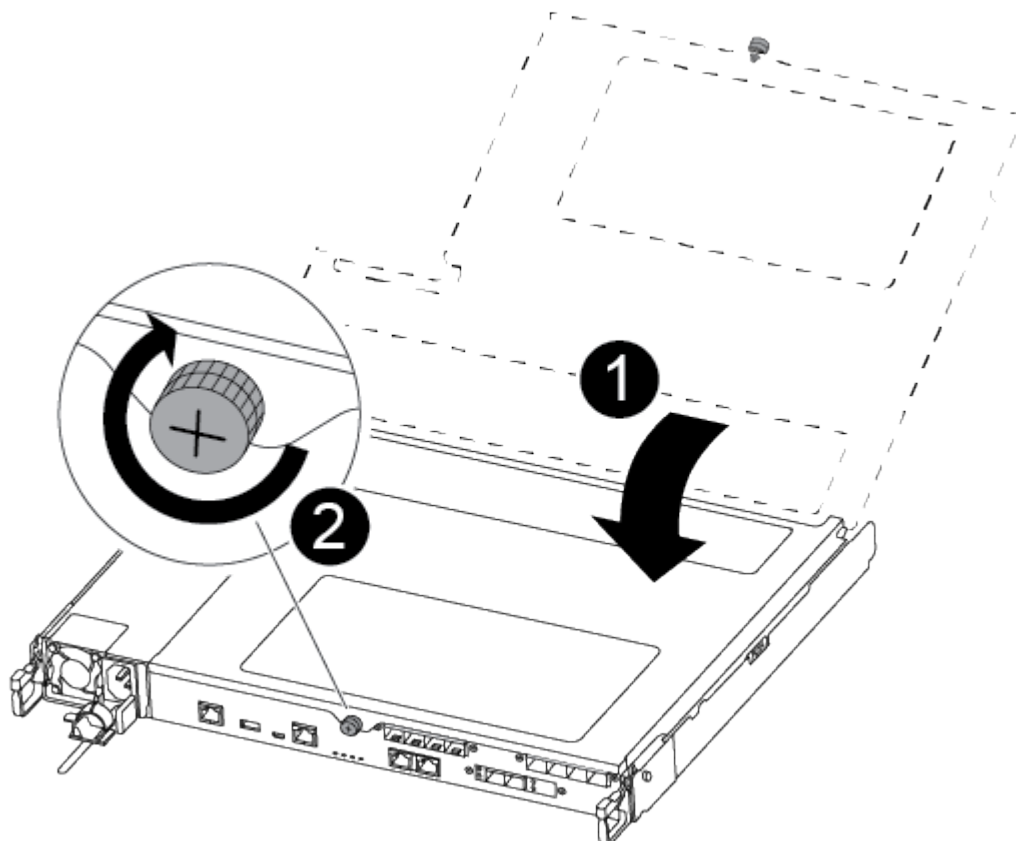

<b>1</b>	Controller module cover
<b>2</b>	Thumbscrew

3. Insert the controller module into the chassis:

- a. Ensure the latching mechanism arms are locked in the fully extended position.
- b. Using both hands, align and gently slide the controller module into the latching mechanism arms until it stops.
- c. Place your index fingers through the finger holes from the inside of the latching mechanism.
- d. Press your thumbs down on the orange tabs on top of the latching mechanism and gently push the controller module over the stop.
- e. Release your thumbs from the top of the latching mechanisms and continue pushing until the latching mechanisms snap into place.

The controller module begins to boot as soon as it is fully seated in the chassis.

The controller module should be fully inserted and flush with the edges of the chassis.

4. Cable the management and console ports only, so that you can access the system to perform the tasks in the following sections.



You will connect the rest of the cables to the controller module later in this procedure.

### Step 5: Return the failed part to NetApp

Return the failed part to NetApp, as described in the RMA instructions shipped with the kit. See the [Part Return and Replacements](#) page for further information.

#### Replace SSD Drive or HDD Drive - ASA C250

You can replace a failed drive nondisruptively while I/O is in progress. The procedure for replacing an SSD is meant for non-spinning drives and the procedure for replacing an HDD is meant for spinning drives.

When a drive fails, the platform logs a warning message to the system console indicating which drive has failed. In addition, both the fault LED on the operator display panel and the fault LED on the failed drive are illuminated.

#### Before you begin

- Follow best practice and install the current version of the Disk Qualification Package (DQP) before replacing a drive.
- Identify the failed drive by running the `storage disk show -broken` command from the system console.

The failed drive appears in the list of failed drives. If it does not, you should wait, and then run the command again.



Depending on the type and capacity, it can take up to several hours for the drive to appear in the list of failed drives.

- Determine whether SED authentication is enabled.

How you replace the drive depends on how the drive is being used. If SED authentication is enabled, you must use the SED replacement instructions in the [ONTAP 9 NetApp Encryption Power Guide](#). These Instructions describe additional steps you must perform before and after replacing an SED.

- Make sure the replacement drive is supported by your platform. See the [NetApp Hardware Universe](#).
- Make sure all other components in the system are functioning properly; if not, you must contact technical support.

#### **About this task**

- Drive firmware is automatically updated (nondisruptively) on new drives that have non current firmware versions.
- When replacing a drive, you must wait one minute between the removal of the failed drive and the insertion of the replacement drive to allow the storage system to recognize the existence of the new drive.

## Option 1: Replace SSD

### Steps

1. If you want to manually assign drive ownership for the replacement drive, you need to disable automatic drive assignment replacement drive, if it is enabled



You manually assign drive ownership and then reenables automatic drive assignment later in this procedure.

- a. Verify whether automatic drive assignment is enabled: `storage disk option show`

You can enter the command on either controller module.

If automatic drive assignment is enabled, the output shows `on` in the “Auto Assign” column (for each controller module).

- b. If automatic drive assignment is enabled, disable it: `storage disk option modify -node node_name -autoassign off`

You must disable automatic drive assignment on both controller modules.

2. Properly ground yourself.
3. Physically identify the failed drive.

When a drive fails, the system logs a warning message to the system console indicating which drive failed. Additionally, the attention (amber) LED on the drive shelf operator display panel and the failed drive illuminate.



The activity (green) LED on a failed drive can be illuminated (solid), which indicates that the drive has power, but should not be blinking, which indicates I/O activity. A failed drive has no I/O activity.

4. Remove the failed drive:
  - a. Press the release button on the drive face to open the cam handle.
  - b. Slide the drive out of the shelf using the cam handle and supporting the drive with your other hand.

5. Wait a minimum of 70 seconds before inserting the replacement drive.

This allows the system to recognize that a drive was removed.

6. Insert the replacement drive:
  - a. With the cam handle in the open position, use both hands to insert the replacement drive.
  - b. Push until the drive stops.
  - c. Close the cam handle so that the drive is fully seated into the midplane and the handle clicks into place.

Be sure to close the cam handle slowly so that it aligns correctly with the face of the drive.

7. Verify that the drive’s activity (green) LED is illuminated.

When the drive's activity LED is solid, it means that the drive has power. When the drive's activity LED is blinking, it means that the drive has power and I/O is in progress. If the drive firmware is automatically updating, the LED blinks.

8. If you are replacing another drive, repeat Steps 3 through 7.
9. If you disabled automatic drive assignment in Step 1, then, manually assign drive ownership and then reenables automatic drive assignment if needed.

- a. Display all unowned drives: `storage disk show -container-type unassigned`

You can enter the command on either controller module.

- b. Assign each drive: `storage disk assign -disk disk_name -owner node_name`

You can enter the command on either controller module.

You can use the wildcard character to assign more than one drive at once.

- c. Reenable automatic drive assignment if needed: `storage disk option modify -node node_name -autoassign on`

You must reenables automatic drive assignment on both controller modules.

10. Return the failed part to NetApp, as described in the RMA instructions shipped with the kit.

Contact technical support at [NetApp Support](#), 888-463-8277 (North America), 00-800-44-638277 (Europe), or +800-800-80-800 (Asia/Pacific) if you need the RMA number or additional help with the replacement procedure.

## Option 2: Replace HDD

1. If you want to manually assign drive ownership for the replacement drive, you need to disable automatic drive assignment replacement drive, if it is enabled



You manually assign drive ownership and then reenables automatic drive assignment later in this procedure.

- a. Verify whether automatic drive assignment is enabled: `storage disk option show`

You can enter the command on either controller module.

If automatic drive assignment is enabled, the output shows `on` in the "Auto Assign" column (for each controller module).

- b. If automatic drive assignment is enabled, disable it: `storage disk option modify -node node_name -autoassign off`

You must disable automatic drive assignment on both controller modules.

2. Properly ground yourself.
3. Gently remove the bezel from the front of the platform.
4. Identify the failed disk drive from the system console warning message and the illuminated fault LED on the disk drive

5. Press the release button on the disk drive face.

Depending on the storage system, the disk drives have the release button located at the top or on the left of the disk drive face.

For example, the following illustration shows a disk drive with the release button located on the top of the disk drive face:

The cam handle on the disk drive springs open partially and the disk drive releases from the midplane.

6. Pull the cam handle to its fully open position to unseat the disk drive from the midplane.

7. Slide out the disk drive slightly and allow the disk to safely spin down, which can take less than one minute, and then, using both hands, remove the disk drive from the disk shelf.

8. With the cam handle in the open position, insert the replacement disk drive into the drive bay, firmly pushing until the disk drive stops.



Wait a minimum of 10 seconds before inserting a new disk drive. This allows the system to recognize that a disk drive was removed.



If your platform drive bays are not fully loaded with drives, it is important to place the replacement drive into the same drive bay from which you removed the failed drive.



Use two hands when inserting the disk drive, but do not place hands on the disk drive boards that are exposed on the underside of the disk carrier.

9. Close the cam handle so that the disk drive is fully seated into the midplane and the handle clicks into place.

Be sure to close the cam handle slowly so that it aligns correctly with the face of the disk drive..

10. If you are replacing another disk drive, repeat Steps 4 through 9.

11. Reinstall the bezel.

12. If you disabled automatic drive assignment in Step 1, then, manually assign drive ownership and then reenale automatic drive assignment if needed.

a. Display all unowned drives: `storage disk show -container-type unassigned`

You can enter the command on either controller module.

b. Assign each drive: `storage disk assign -disk disk_name -owner owner_name`

You can enter the command on either controller module.

You can use the wildcard character to assign more than one drive at once.

c. Reenable automatic drive assignment if needed: `storage disk option modify -node node_name -autoassign on`



You must reenable automatic drive assignment on both controller modules.

13. Return the failed part to NetApp, as described in the RMA instructions shipped with the kit.

Contact technical support at [NetApp Support](#), 888-463-8277 (North America), 00-800-44-638277 (Europe), or +800-800-80-800 (Asia/Pacific) if you need the RMA number or additional help with the replacement procedure.

## Replace a fan - ASA C250

To replace a fan, remove the failed fan module and replace it with a new fan module.

### Step 1: Shut down the impaired controller

To shut down the impaired controller, you must determine the status of the controller and, if necessary, take over the controller so that the healthy controller continues to serve data from the impaired controller storage.

#### About this task

- If you have a SAN system, you must have checked event messages (`cluster kernel-service show`) for the impaired controller SCSI blade. The `cluster kernel-service show` command (from `priv advanced` mode) displays the node name, quorum status of that node, availability status of that node, and operational status of that node.

Each SCSI-blade process should be in quorum with the other nodes in the cluster. Any issues must be resolved before you proceed with the replacement.

- If you have a cluster with more than two nodes, it must be in quorum. If the cluster is not in quorum or a healthy controller shows `false` for eligibility and health, you must correct the issue before shutting down the impaired controller; see [Synchronize a node with the cluster](#).

#### Steps

1. If AutoSupport is enabled, suppress automatic case creation by invoking an AutoSupport message:  

```
system node autosupport invoke -node * -type all -message MAINT=<# of hours>h
```

The following AutoSupport message suppresses automatic case creation for two hours: `cluster1:>`  

```
system node autosupport invoke -node * -type all -message MAINT=2h
```

2. Disable automatic giveback from the console of the healthy controller: 

```
storage failover modify -node local -auto-giveback false
```



When you see *Do you want to disable auto-giveback?*, enter `y`.

3. Take the impaired controller to the LOADER prompt:

If the impaired controller is displaying...	Then...
The LOADER prompt	Go to the next step.
Waiting for giveback...	Press Ctrl-C, and then respond <code>y</code> when prompted.

If the impaired controller is displaying...	Then...
System prompt or password prompt	Take over or halt the impaired controller from the healthy controller: <pre>storage failover takeover -ofnode impaired_node_name</pre> When the impaired controller shows Waiting for giveback..., press Ctrl-C, and then respond <i>y</i> .

## Step 2: Remove the controller module

You must remove the controller module from the chassis when you replace a component inside the controller module.

Make sure that you label the cables so that you know where they came from.

1. If you are not already grounded, properly ground yourself.
2. Unplug the controller module power supplies from the source.
3. Release the power cable retainers, and then unplug the cables from the power supplies.
4. Insert your forefinger into the latching mechanism on either side of the controller module, press the lever with your thumb, and gently pull the controller a few inches out of the chassis.



If you have difficulty removing the controller module, place your index fingers through the finger holes from the inside (by crossing your arms).

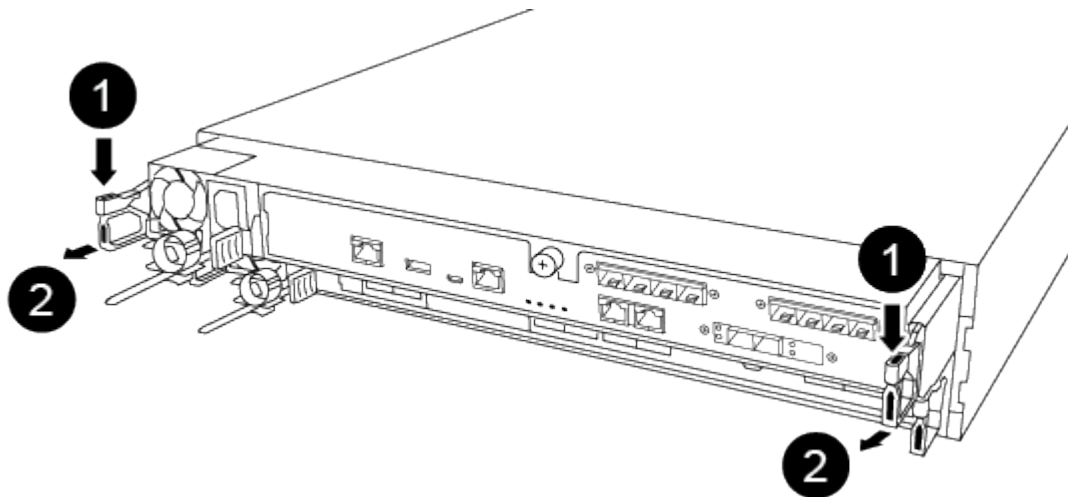

1	Lever
2	Latching mechanism

5. Using both hands, grasp the controller module sides and gently pull it out of the chassis and set it on a flat, stable surface.

6. Turn the thumbscrew on the front of the controller module anti-clockwise and open the controller module cover.

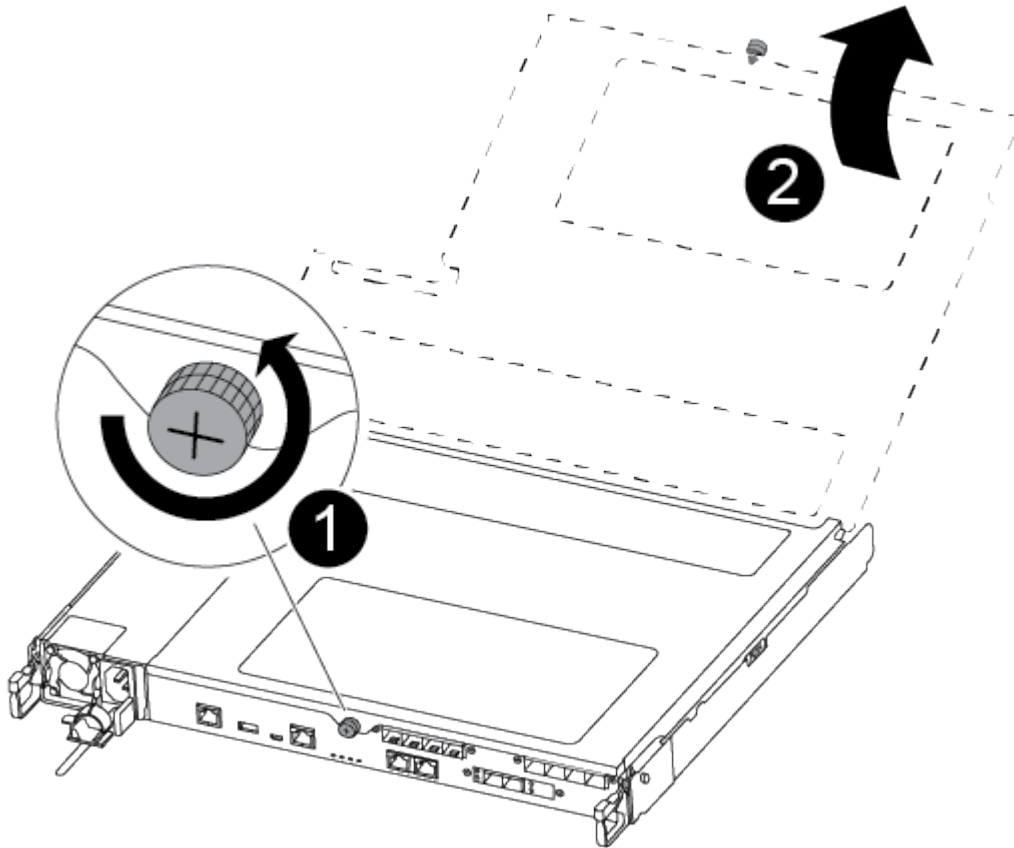

1	Thumbscrew
2	Controller module cover

### Step 3: Replace a fan

To replace a fan, remove the failed fan module and replace it with a new fan module.

Use the following video or the tabulated steps to replace a fan:

#### [Animation - Replace a fan](#)

1. Identify the fan module that you must replace by checking the console error messages or by locating the lit LED for the fan module on the motherboard.
2. Remove the fan module by pinching the side of the fan module, and then lifting the fan module straight out of the controller module.

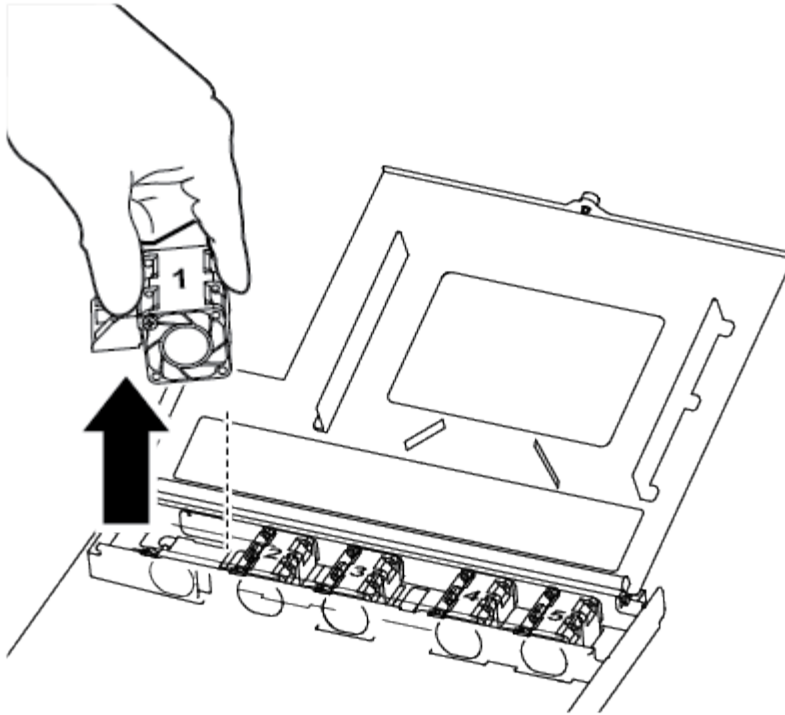

1

Fan module

3. Align the edges of the replacement fan module with the opening in the controller module, and then slide the replacement fan module into the controller module.

#### **Step 4: Reinstall the controller module**

After you replace a component within the controller module, you must reinstall the controller module in the system chassis and boot it.

1. Close the controller module cover and tighten the thumbscrew.

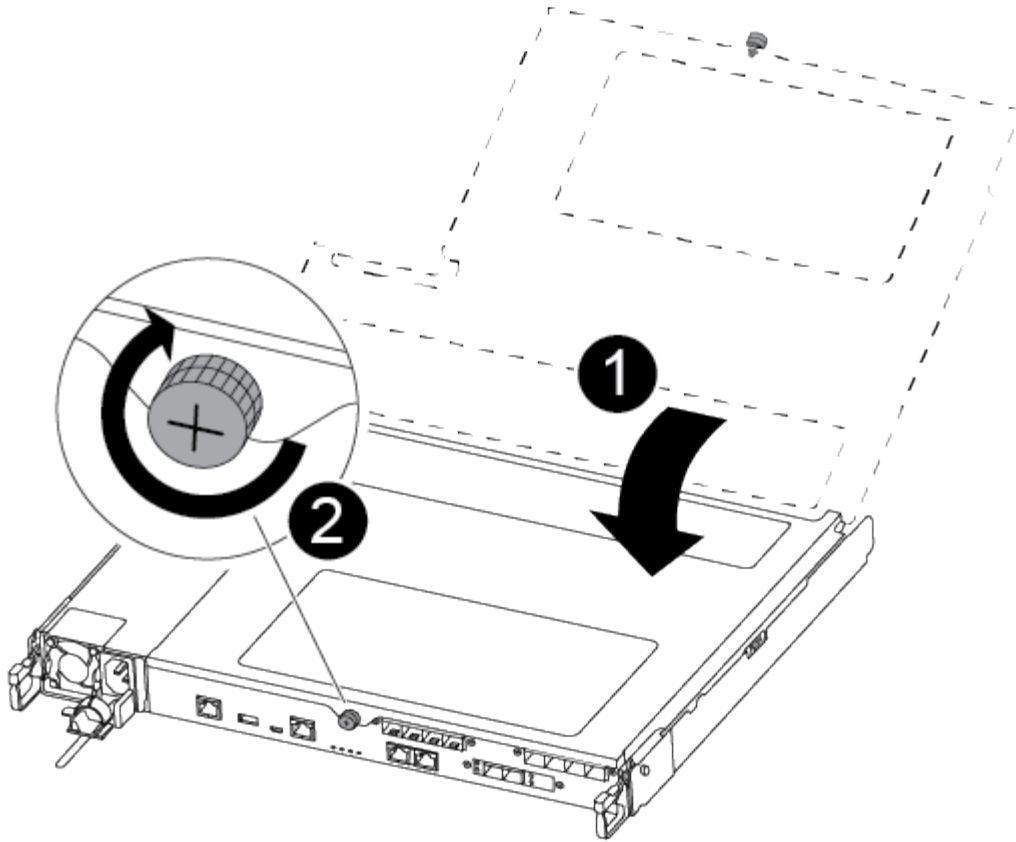

1	Controller module cover
2	Thumbscrew

2. Insert the controller module into the chassis:

- a. Ensure the latching mechanism arms are locked in the fully extended position.
- b. Using both hands, align and gently slide the controller module into the latching mechanism arms until it stops.
- c. Place your index fingers through the finger holes from the inside of the latching mechanism.
- d. Press your thumbs down on the orange tabs on top of the latching mechanism and gently push the controller module over the stop.
- e. Release your thumbs from the top of the latching mechanisms and continue pushing until the latching mechanisms snap into place.

The controller module begins to boot as soon as it is fully seated in the chassis. Be prepared to interrupt the boot process.

The controller module should be fully inserted and flush with the edges of the chassis.

3. Recable the system, as needed.

4. Return the controller to normal operation by giving back its storage: `storage failover giveback -ofnode impaired_node_name`

5. If automatic giveback was disabled, reenable it: 

```
storage failover modify -node local -auto-giveback true
```

### Step 5: Return the failed part to NetApp

Return the failed part to NetApp, as described in the RMA instructions shipped with the kit. See the [Part Return and Replacements](#) page for further information.

#### Replace or install a mezzanine card - ASA C250

To replace a failed mezzanine card, you must remove the cables and any SFP or QSFP modules, replace the card, reinstall the SFP or QSFP modules and recable the cards. To install a new mezzanine card, you must have the appropriate cables and SFP or QSFP modules.

#### About this task

- You can use this procedure with all versions of ONTAP supported by your system
- All other components in the system must be functioning properly; if not, you must contact technical support.

### Step 1: Shut down the impaired controller

To shut down the impaired controller, you must determine the status of the controller and, if necessary, take over the controller so that the healthy controller continues to serve data from the impaired controller storage.

#### About this task

- If you have a SAN system, you must have checked event messages (`cluster kernel-service show`) for the impaired controller SCSI blade. The `cluster kernel-service show` command (from `priv advanced mode`) displays the node name, quorum status of that node, availability status of that node, and operational status of that node.

Each SCSI-blade process should be in quorum with the other nodes in the cluster. Any issues must be resolved before you proceed with the replacement.

- If you have a cluster with more than two nodes, it must be in quorum. If the cluster is not in quorum or a healthy controller shows `false` for eligibility and health, you must correct the issue before shutting down the impaired controller; see [Synchronize a node with the cluster](#).

### Steps

1. If AutoSupport is enabled, suppress automatic case creation by invoking an AutoSupport message:  

```
system node autosupport invoke -node * -type all -message MAINT=<# of hours>h
```

The following AutoSupport message suppresses automatic case creation for two hours: `cluster1:>`  

```
system node autosupport invoke -node * -type all -message MAINT=2h
```

2. Disable automatic giveback from the console of the healthy controller: 

```
storage failover modify -node local -auto-giveback false
```



When you see *Do you want to disable auto-giveback?*, enter *y*.

3. Take the impaired controller to the LOADER prompt:

If the impaired controller is displaying...	Then...
The LOADER prompt	Go to the next step.
Waiting for giveback...	Press Ctrl-C, and then respond <code>y</code> when prompted.
System prompt or password prompt	Take over or halt the impaired controller from the healthy controller: <pre>storage failover takeover -ofnode impaired_node_name</pre> When the impaired controller shows Waiting for giveback..., press Ctrl-C, and then respond <code>y</code> .

## Step 2: Remove the controller module

Remove the controller module from the chassis when you replace a component inside the controller module.

Make sure that you label the cables so that you know where they came from.

1. If you are not already grounded, properly ground yourself.
2. Unplug the controller module power supplies from the source.
3. Release the power cable retainers, and then unplug the cables from the power supplies.
4. Insert your forefinger into the latching mechanism on either side of the controller module, press the lever with your thumb, and gently pull the controller a few inches out of the chassis.



If you have difficulty removing the controller module, place your index fingers through the finger holes from the inside (by crossing your arms).

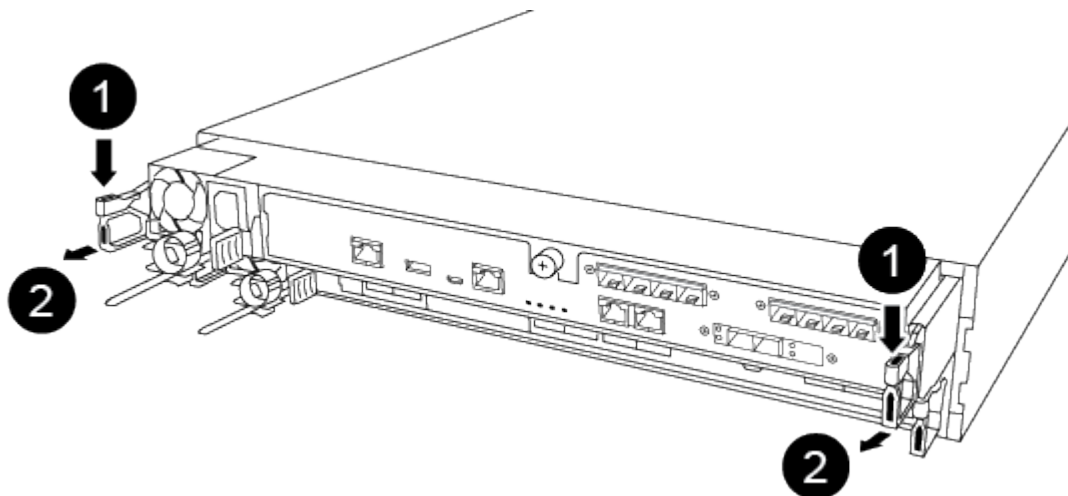

1	Lever
---	-------

<b>2</b>	Latching mechanism
----------	--------------------

5. Using both hands, grasp the controller module sides and gently pull it out of the chassis and set it on a flat, stable surface.
6. Turn the thumbscrew on the front of the controller module anti-clockwise and open the controller module cover.

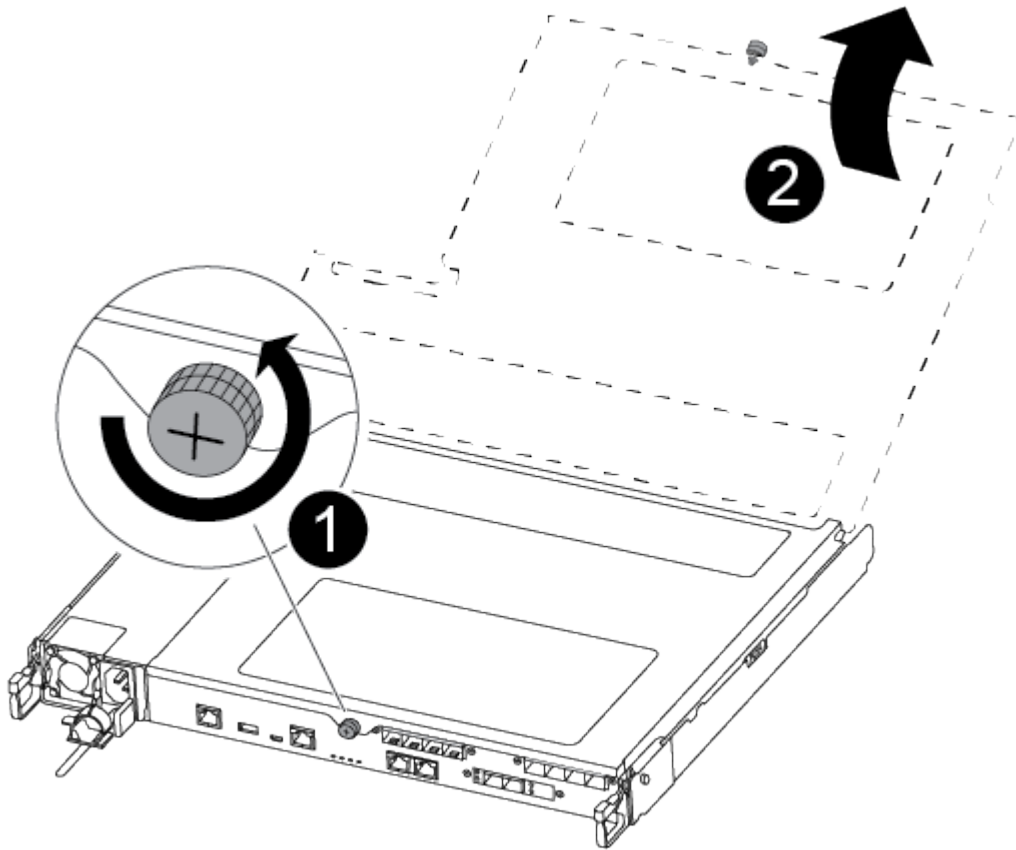

<b>1</b>	Thumbscrew
<b>2</b>	Controller module cover.

### Step 3: Replace or install a mezzanine card

To replace a mezzanine card, you must remove the impaired card and install the replacement card; to install a mezzanine card, you must remove the faceplate and install the new card.

Use the following video or the tabulated steps to replace a mezzanine card:

[Animation - Replace a mezzanine card](#)

1. To replace a mezzanine card:
2. Locate and replace the impaired mezzanine card on your controller module.



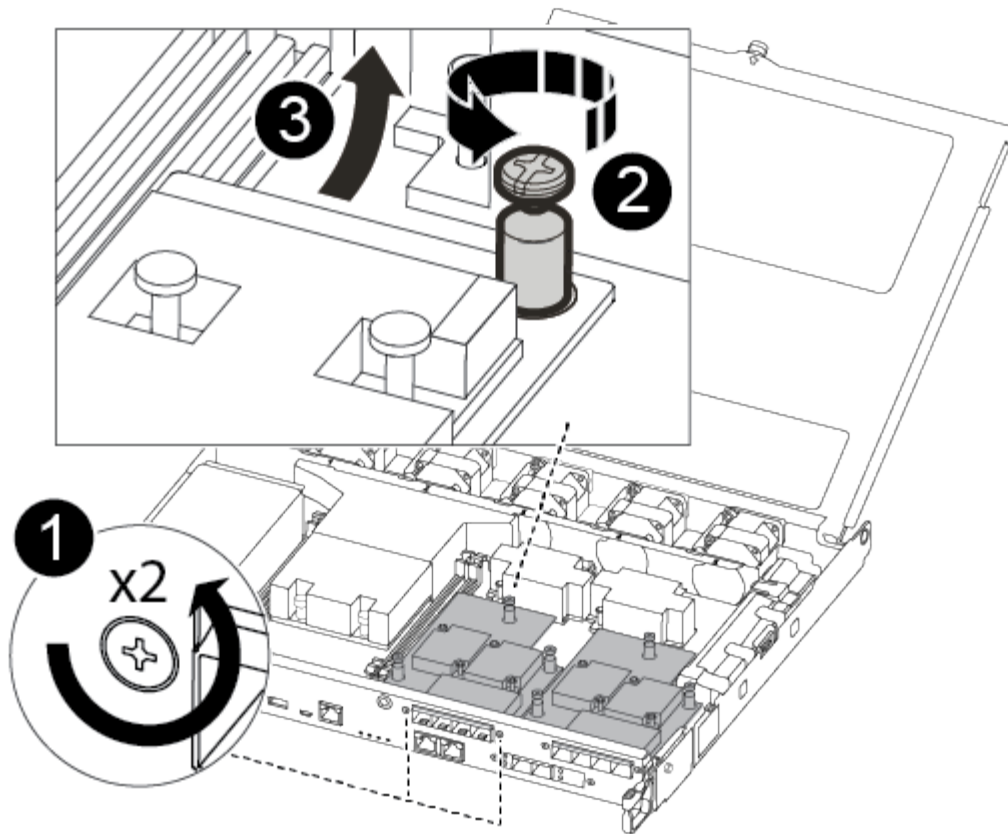

1	Remove screws on the face of the controller module.
2	Loosen the screw in the controller module.
3	Remove the mezzanine card.

a. Unplug any cabling associated with the impaired mezzanine card.

Make sure that you label the cables so that you know where they came from.

b. Remove any SFP or QSFP modules that might be in the impaired mezzanine card and set it aside.

c. Using the #1 magnetic screwdriver, remove the screws from the face of the controller module and set them aside safely on the magnet.

d. Using the #1 magnetic screwdriver, loosen the screw on the impaired mezzanine card.

e. Using the #1 magnetic screwdriver, gently lift the impaired mezzanine card directly out of the socket and set it aside.

f. Remove the replacement mezzanine card from the antistatic shipping bag and align it to the inside face of the controller module.

g. Gently align the replacement mezzanine card into place.

h. Using the #1 magnetic screwdriver, insert and tighten the screws on the face of the controller module and on the mezzanine card.



Do not apply force when tightening the screw on the mezzanine card; you might crack it.

- i. Insert any SFP or QSFP modules that were removed from the impaired mezzanine card to the replacement mezzanine card.

3. To install a mezzanine card:

4. You install a new mezzanine card if your system does not have one.

- a. Using the #1 magnetic screwdriver, remove the screws from the face of the controller module and the faceplate covering the mezzanine card slot, and set them aside safely on the magnet.
- b. Remove the mezzanine card from the antistatic shipping bag and align it to the inside face of the controller module.
- c. Gently align the mezzanine card into place.
- d. Using the #1 magnetic screwdriver, insert and tighten the screws on the face of the controller module and on the mezzanine card.



Do not apply force when tightening the screw on the mezzanine card; you might crack it.

#### Step 4: Reinstall the controller module

After you replace a component within the controller module, you must reinstall the controller module in the system chassis and boot it.

1. Close the controller module cover and tighten the thumbscrew.

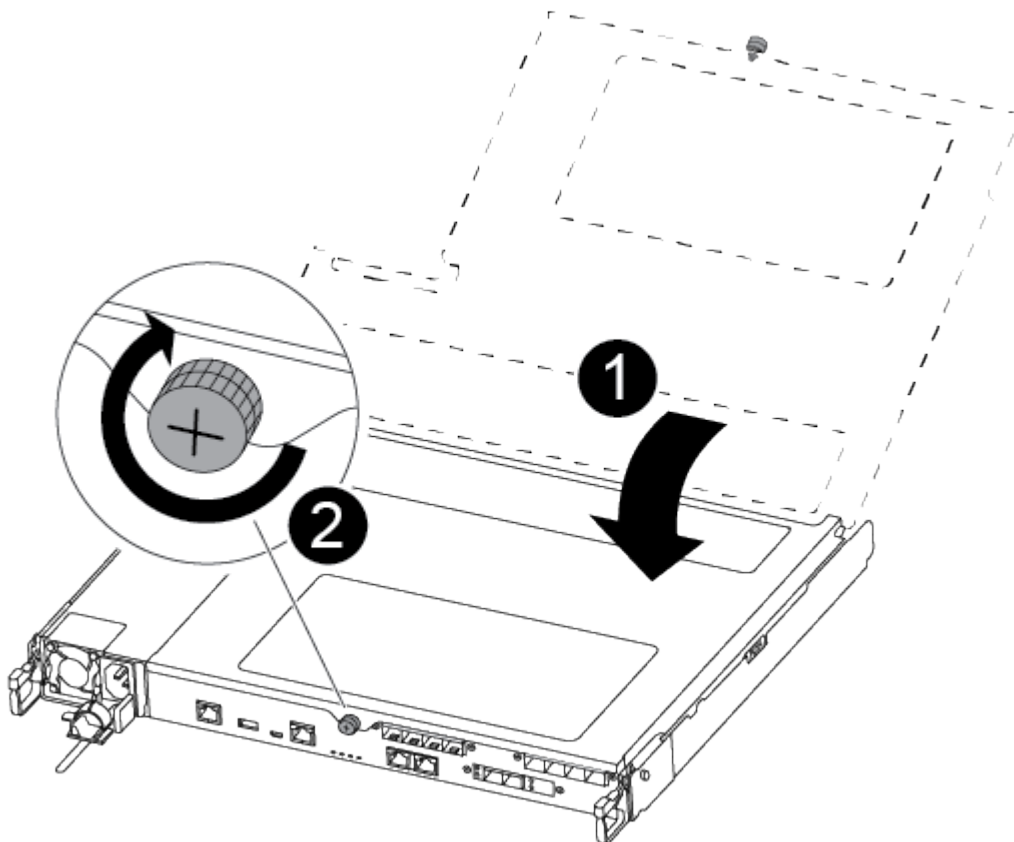

<b>1</b>	Controller module cover
<b>2</b>	Thumbscrew

2. Insert the controller module into the chassis:

- a. Ensure the latching mechanism arms are locked in the fully extended position.
- b. Using both hands, align and gently slide the controller module into the latching mechanism arms until it stops.
- c. Place your index fingers through the finger holes from the inside of the latching mechanism.
- d. Press your thumbs down on the orange tabs on top of the latching mechanism and gently push the controller module over the stop.
- e. Release your thumbs from the top of the latching mechanisms and continue pushing until the latching mechanisms snap into place.

The controller module begins to boot as soon as it is fully seated in the chassis. Be prepared to interrupt the boot process.

The controller module should be fully inserted and flush with the edges of the chassis.

3. Recable the system, as needed.

4. Return the controller to normal operation by giving back its storage: `storage failover giveback -ofnode impaired_node_name`

5. If automatic giveback was disabled, reenable it: `storage failover modify -node local -auto -giveback true`

### Step 5: Return the failed part to NetApp

Return the failed part to NetApp, as described in the RMA instructions shipped with the kit. See the [Part Return and Replacements](#) page for further information.

#### Replace the NVMEM battery - ASA C250

To replace an NVMEM battery in the system, you must remove the controller module from the system, open it, replace the battery, and close and replace the controller module.

All other components in the system must be functioning properly; if not, you must contact technical support.

### Step 1: Shut down the impaired controller

To shut down the impaired controller, you must determine the status of the controller and, if necessary, take over the controller so that the healthy controller continues to serve data from the impaired controller storage.

#### About this task

- If you have a SAN system, you must have checked event messages (`cluster kernel-service show`) for the impaired controller SCSI blade. The `cluster kernel-service show` command (from `priv advanced mode`) displays the node name, quorum status of that node, availability status of that node, and operational status of that node.

Each SCSI-blade process should be in quorum with the other nodes in the cluster. Any issues must be resolved before you proceed with the replacement.

- If you have a cluster with more than two nodes, it must be in quorum. If the cluster is not in quorum or a healthy controller shows false for eligibility and health, you must correct the issue before shutting down the impaired controller; see [Synchronize a node with the cluster](#).

## Steps

1. If AutoSupport is enabled, suppress automatic case creation by invoking an AutoSupport message:

```
system node autosupport invoke -node * -type all -message MAINT=<# of hours>h
```

The following AutoSupport message suppresses automatic case creation for two hours: `cluster1:>`

```
system node autosupport invoke -node * -type all -message MAINT=2h
```

2. Disable automatic giveback from the console of the healthy controller: `storage failover modify -node local -auto-giveback false`



When you see *Do you want to disable auto-giveback?*, enter *y*.

3. Take the impaired controller to the LOADER prompt:

If the impaired controller is displaying...	Then...
The LOADER prompt	Go to the next step.
Waiting for giveback...	Press Ctrl-C, and then respond <i>y</i> when prompted.
System prompt or password prompt	Take over or halt the impaired controller from the healthy controller: <code>storage failover takeover -ofnode impaired_node_name</code>  When the impaired controller shows Waiting for giveback..., press Ctrl-C, and then respond <i>y</i> .

## Step 2: Remove the controller module

You must remove the controller module from the chassis when you replace a component inside the controller module.

Make sure that you label the cables so that you know where they came from.

1. If you are not already grounded, properly ground yourself.
2. Unplug the controller module power supplies from the source.
3. Release the power cable retainers, and then unplug the cables from the power supplies.
4. Insert your forefinger into the latching mechanism on either side of the controller module, press the lever with your thumb, and gently pull the controller a few inches out of the chassis.



If you have difficulty removing the controller module, place your index fingers through the finger holes from the inside (by crossing your arms).

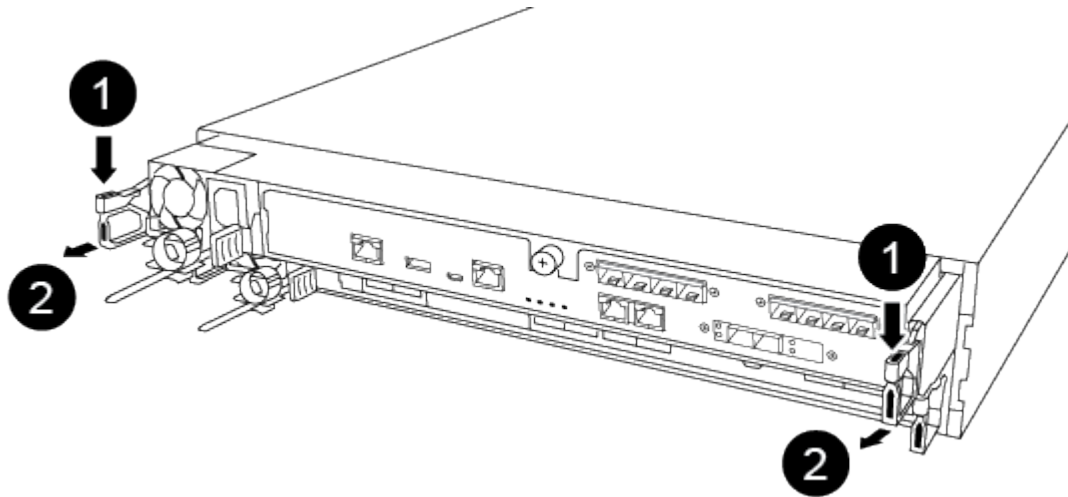

1	Lever
2	Latching mechanism

- Using both hands, grasp the controller module sides and gently pull it out of the chassis and set it on a flat, stable surface.
- Turn the thumbscrew on the front of the controller module anti-clockwise and open the controller module cover.

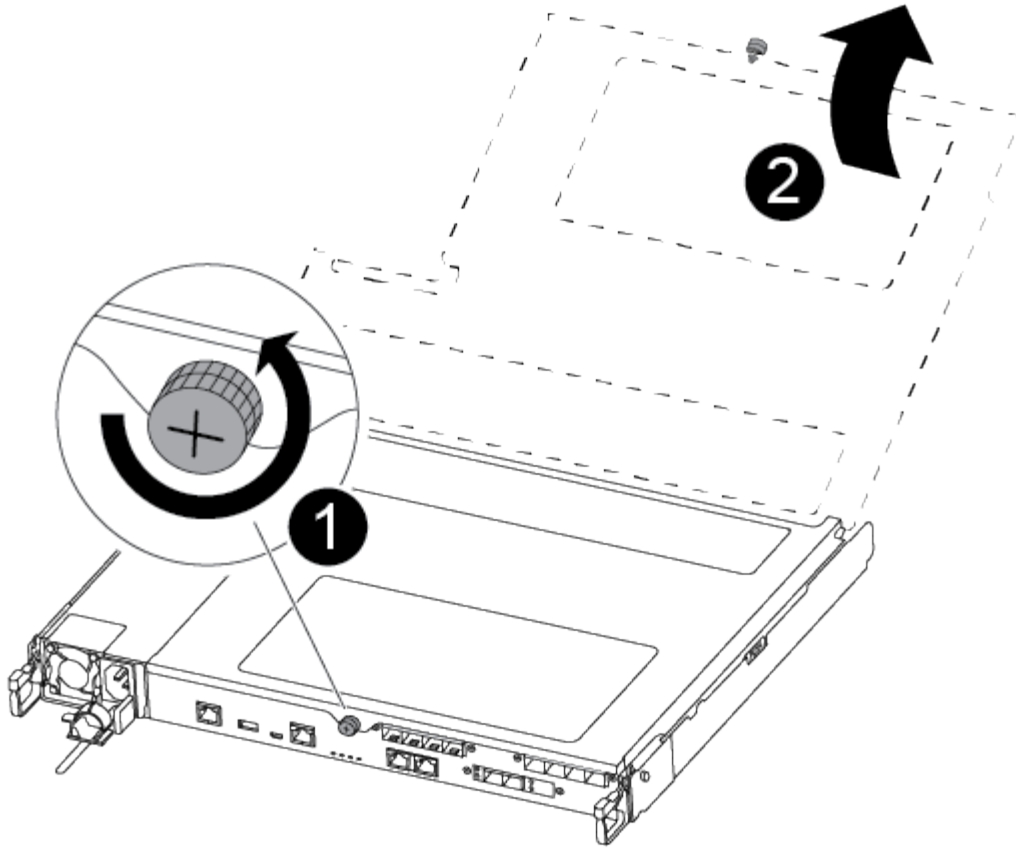

1	Thumbscrew
2	Controller module cover.

### Step 3: Replace the NVMEM battery

To replace the NVMEM battery, you must remove the failed battery from the controller module and install the replacement battery into the controller module.

Use the following video or the tabulated steps to replace the NVMEM battery:

[Animation - Replace the NVMEM battery](#)

1. Locate and replace the impaired NVMEM battery on your controller module.



It is recommended that you follow the illustrated instructions in the order listed.

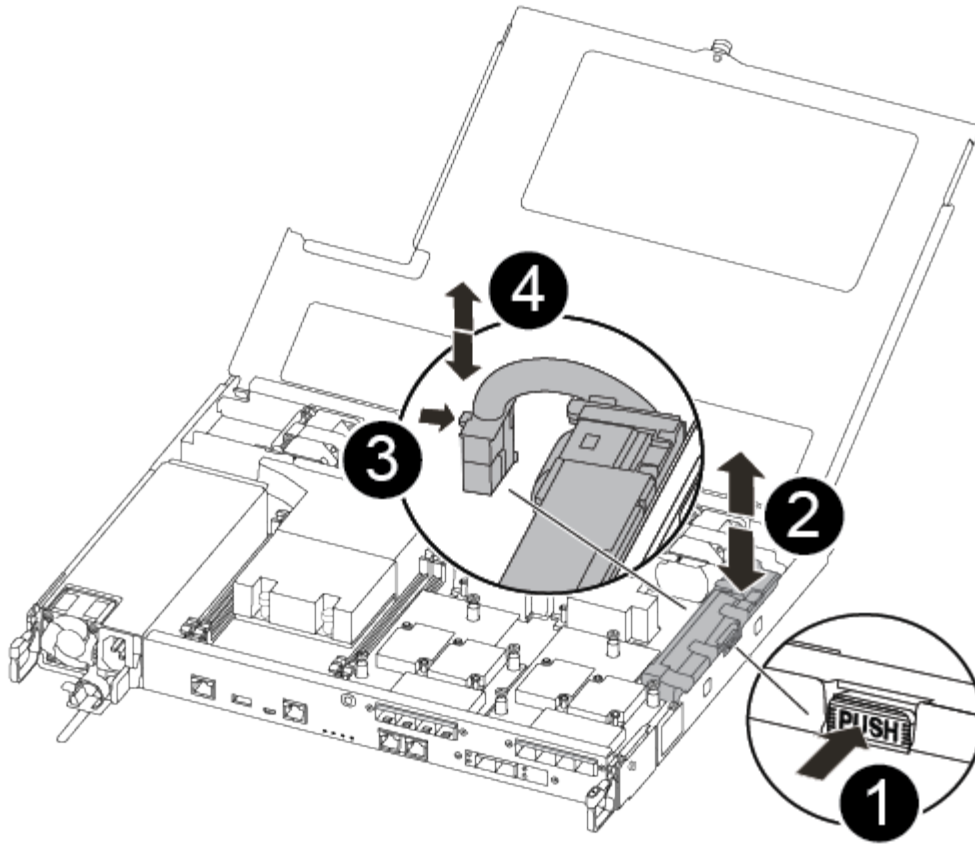

1	Squeeze the clip on the face of the battery plug.
2	Unplug the battery cable from the socket.
3	Grasp the battery and press the blue locking tab marked PUSH.
4	Lift the battery out of the holder and controller module.

2. Locate the battery plug and squeeze the clip on the face of the battery plug to release the plug from the socket.
3. Grasp the battery and press the blue locking tab marked PUSH, and then lift the battery out of the holder and controller module and set it aside.
4. Remove the replacement NV battery from the antistatic shipping bag and align it to the battery holder.
5. Insert the replacement NV battery plug into the socket.
6. Slide the battery pack down along the sheet metal side wall until the support tabs on the side wall hook into the slots on the battery pack, and the battery pack latch engages and clicks into the opening on the side wall.
7. Press firmly down on the battery pack to make sure that it is locked into place.

#### Step 4: Install the controller module

After you have replaced the component in the controller module, you must reinstall the controller module into the chassis, and then boot it.

You can use the following illustration or the written steps to install the replacement controller module in the chassis.

1. Close the controller module cover and tighten the thumbscrew.

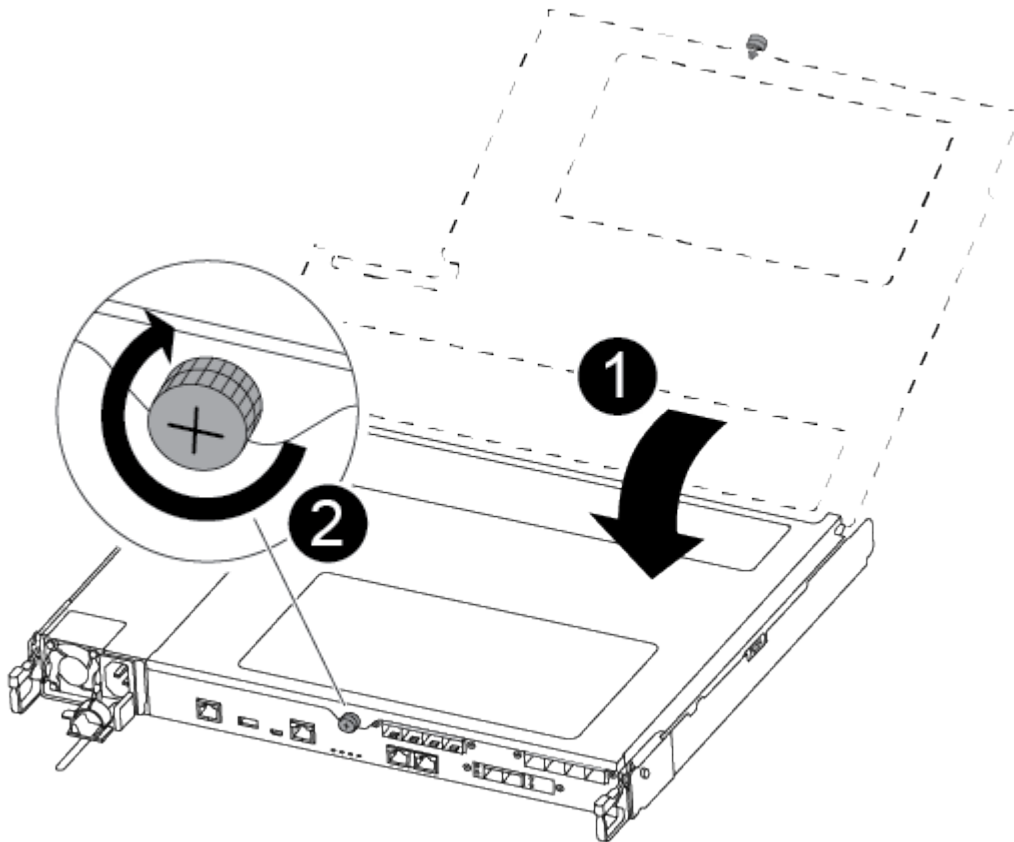

1	Controller module cover
2	Thumbscrew

2. Insert the controller module into the chassis:
  - a. Ensure the latching mechanism arms are locked in the fully extended position.
  - b. Using both hands, align and gently slide the controller module into the latching mechanism arms until it stops.
  - c. Place your index fingers through the finger holes from the inside of the latching mechanism.
  - d. Press your thumbs down on the orange tabs on top of the latching mechanism and gently push the controller module over the stop.
  - e. Release your thumbs from the top of the latching mechanisms and continue pushing until the latching mechanisms snap into place.



The controller module begins to boot as soon as it is fully seated in the chassis.

The controller module should be fully inserted and flush with the edges of the chassis.

3. Cable the management and console ports only, so that you can access the system to perform the tasks in the following sections.



You will connect the rest of the cables to the controller module later in this procedure.

### Step 5: Return the failed part to NetApp

Return the failed part to NetApp, as described in the RMA instructions shipped with the kit. See the [Part Return and Replacements](#) page for further information.

#### Replace a power supply - ASA C250

Replacing a power supply (PSU) involves disconnecting the target PSU from the power source, unplugging the power cable, removing the old PSU and installing the replacement PSU, and then reconnecting it to the power source.

- The power supplies are redundant and hot-swappable.
- This procedure is written for replacing one PSU at a time.



It is a best practice to replace the PSU within two minutes of removing it from the chassis. The system continues to function, but ONTAP sends messages to the console about the degraded PSU until the PSU is replaced.

- Power supplies are auto-ranging.



Do not mix PSUs with different efficiency ratings. Always replace like for like.

Use the appropriate procedure for your type of PSU; AC or DC.

### Option 1: Replace an AC PSU

Use the following video or the tabulated steps to replace the PSU:

#### Animation - Replace the AC PSU

1. If you are not already grounded, properly ground yourself.
2. Identify the PSU you want to replace, based on console error messages or through the red Fault LED on the PSU.
3. Disconnect the PSU:
  - a. Open the power cable retainer, and then unplug the power cable from the PSU.
4. Remove the PSU by rotating the handle up, press the locking tab, and then pull the PSU out of the controller module.



The PSU is short. Always use two hands to support it when removing it from the controller module so that it does not suddenly swing free from the controller module and injure you.

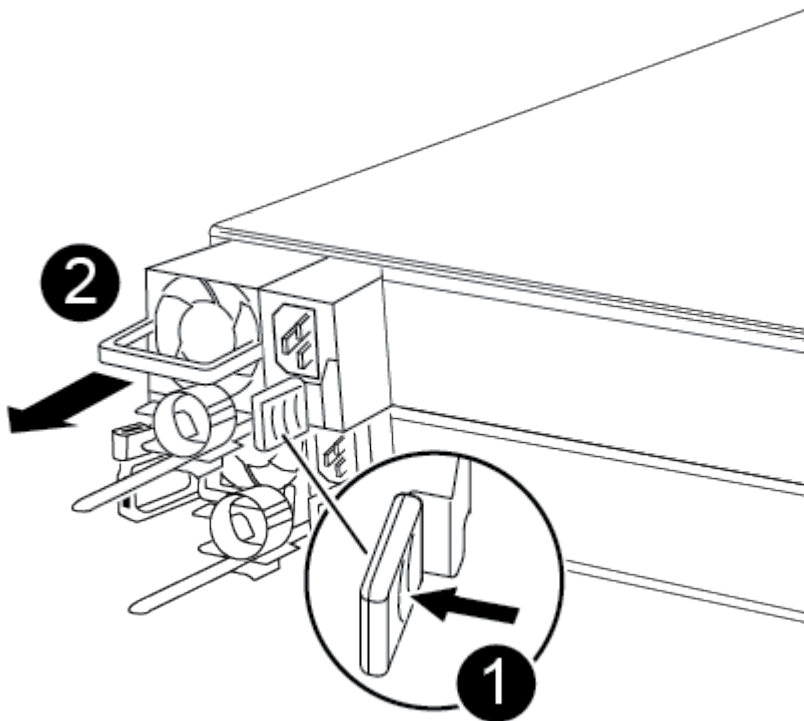

<b>1</b>	Blue PSU locking tab
<b>2</b>	Power supply

5. Install the replacement PSU in the controller module:
  - a. Using both hands, support and align the edges of the PSU with the opening in the controller module.

- b. Gently push the PSU into the controller module until the locking tab clicks into place.

The power supplies will only properly engage with the internal connector and lock in place one way.



To avoid damaging the internal connector, do not use excessive force when sliding the PSU into the system.

6. Reconnect the PSU cabling:
  - a. Reconnect the power cable to the PSU.
  - b. Secure the power cable to the PSU using the power cable retainer.

Once power is restored to the PSU, the status LED should be green.

7. Return the failed part to NetApp, as described in the RMA instructions shipped with the kit. See the [Part Return and Replacements](#) page for further information.

### Option 2: Replace a DC PSU

To replace a DC PSU, complete the following steps.

1. If you are not already grounded, properly ground yourself.
2. Identify the PSU you want to replace, based on console error messages or through the red Fault LED on the PSU.
3. Disconnect the PSU:
  - a. Unscrew the D-SUB DC power cable connector using the thumb screws on the plug.
  - b. Unplug the power cable from the PSU and set it aside.
4. Remove the PSU by rotating the handle up, press the locking tab, and then pull PSU out of the controller module.



The PSU is short. Always use two hands to support it when removing it from the controller module so that it does not suddenly swing free from the controller module and injure you.

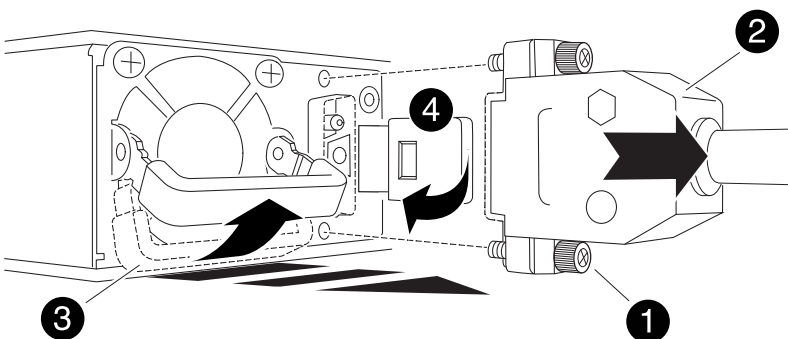

1	Thumb screws
2	D-SUB DC power cable connector

3	Power supply handle
4	Blue PSU locking tab

5. Install the replacement PSU in the controller module:

- a. Using both hands, support and align the edges of the PSU with the opening in the controller module.
- b. Gently push the PSU into the controller module until the locking tab clicks into place.

The power supplies will only properly engage with the internal connector and lock in place one way.



To avoid damaging the internal connector, do not use excessive force when sliding the PSU into the system.

6. Reconnect the D-SUB DC power cable:

- a. Plug the power cable connector into the PSU.
- b. Secure the power cable to the PSU with the thumbscrews.

Once power is restored to the PSU, the status LED should be green.

7. Return the failed part to NetApp, as described in the RMA instructions shipped with the kit. See the [Part Return and Replacements](#) page for further information.

### Replace the real-time clock battery - ASA C250

You replace the real-time clock (RTC) battery in the controller module so that your system's services and applications that depend on accurate time synchronization continue to function.

- You can use this procedure with all versions of ONTAP supported by your system
- All other components in the system must be functioning properly; if not, you must contact technical support.

#### Step 1: Shut down the impaired controller

To shut down the impaired controller, you must determine the status of the controller and, if necessary, take over the controller so that the healthy controller continues to serve data from the impaired controller storage.

#### About this task

- If you have a SAN system, you must have checked event messages (`cluster kernel-service show`) for the impaired controller SCSI blade. The `cluster kernel-service show` command (from `priv advanced` mode) displays the node name, quorum status of that node, availability status of that node, and operational status of that node.

Each SCSI-blade process should be in quorum with the other nodes in the cluster. Any issues must be resolved before you proceed with the replacement.

- If you have a cluster with more than two nodes, it must be in quorum. If the cluster is not in quorum or a

healthy controller shows false for eligibility and health, you must correct the issue before shutting down the impaired controller; see [Synchronize a node with the cluster](#).

## Steps

1. If AutoSupport is enabled, suppress automatic case creation by invoking an AutoSupport message:  
`system node autosupport invoke -node * -type all -message MAINT=<# of hours>h`

The following AutoSupport message suppresses automatic case creation for two hours: `cluster1:>`  
`system node autosupport invoke -node * -type all -message MAINT=2h`

2. Disable automatic giveback from the console of the healthy controller: `storage failover modify -node local -auto-giveback false`



When you see *Do you want to disable auto-giveback?*, enter *y*.

3. Take the impaired controller to the LOADER prompt:

If the impaired controller is displaying...	Then...
The LOADER prompt	Go to the next step.
Waiting for giveback...	Press Ctrl-C, and then respond <i>y</i> when prompted.
System prompt or password prompt	Take over or halt the impaired controller from the healthy controller: <code>storage failover takeover -ofnode impaired_node_name</code>  When the impaired controller shows Waiting for giveback..., press Ctrl-C, and then respond <i>y</i> .

## Step 2: Remove the controller module

You must remove the controller module from the chassis when you replace a component inside the controller module.

Make sure that you label the cables so that you know where they came from.

1. If you are not already grounded, properly ground yourself.
2. Unplug the controller module power supplies from the source.
3. Release the power cable retainers, and then unplug the cables from the power supplies.
4. Insert your forefinger into the latching mechanism on either side of the controller module, press the lever with your thumb, and gently pull the controller a few inches out of the chassis.



If you have difficulty removing the controller module, place your index fingers through the finger holes from the inside (by crossing your arms).

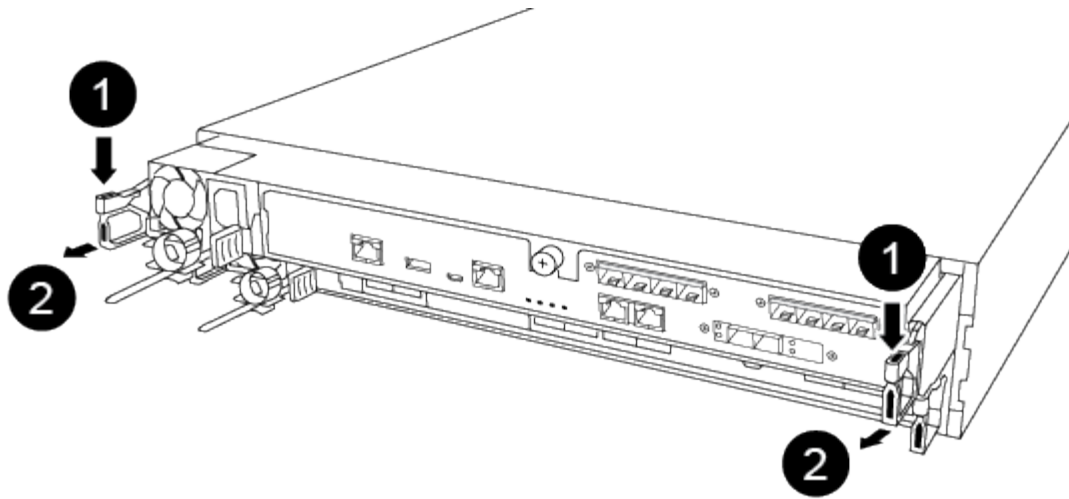

1	Lever
2	Latching mechanism

5. Using both hands, grasp the controller module sides and gently pull it out of the chassis and set it on a flat, stable surface.
6. Turn the thumbscrew on the front of the controller module anti-clockwise and open the controller module cover.

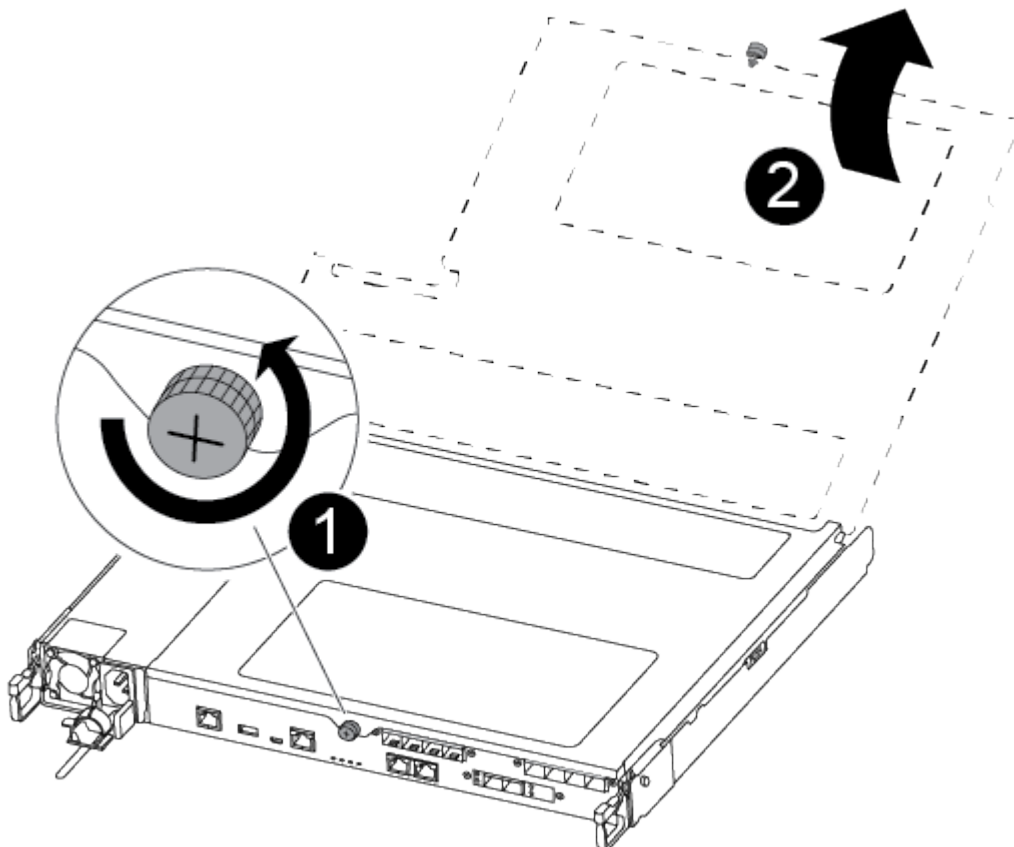

1	Thumbscrew
2	Controller module cover.

7. Lift out the air duct cover.

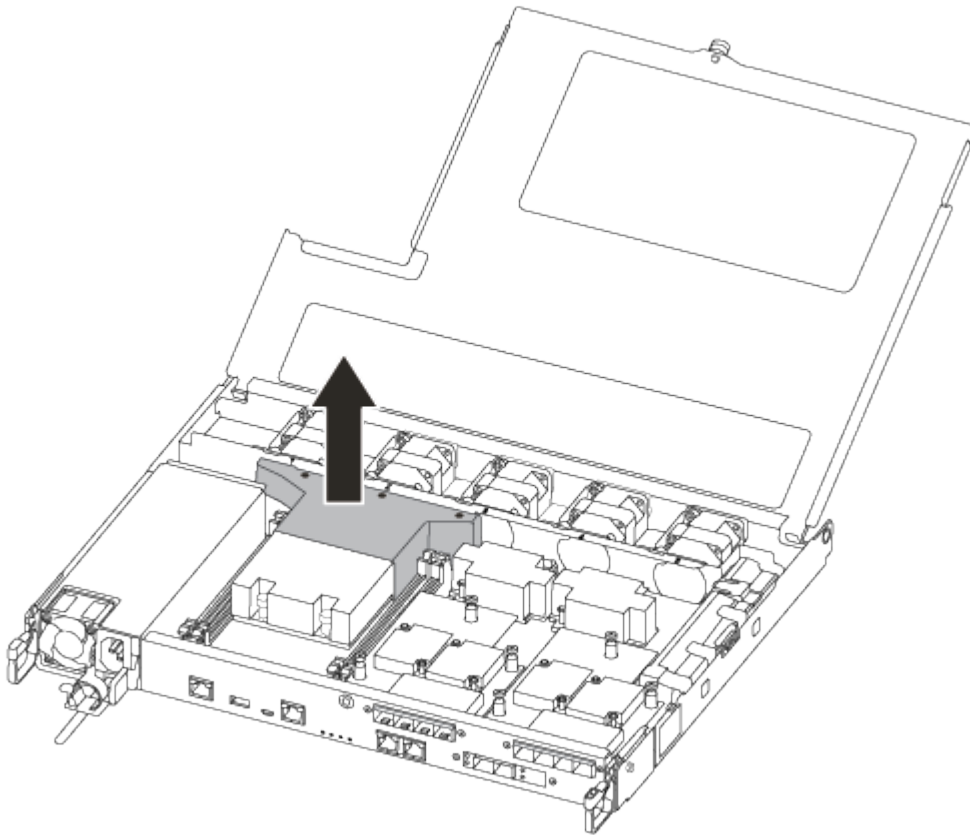

### Step 3: Replace the RTC battery

To replace the RTC battery, locate it inside the controller and follow the specific sequence of steps.

Use the following video or the tabulated steps to replace the RTC battery:

[Animation - Replace the RTC battery](#)

1. Locate the RTC battery between the heatsink and the midplane and remove it exactly as shown in the graphic.

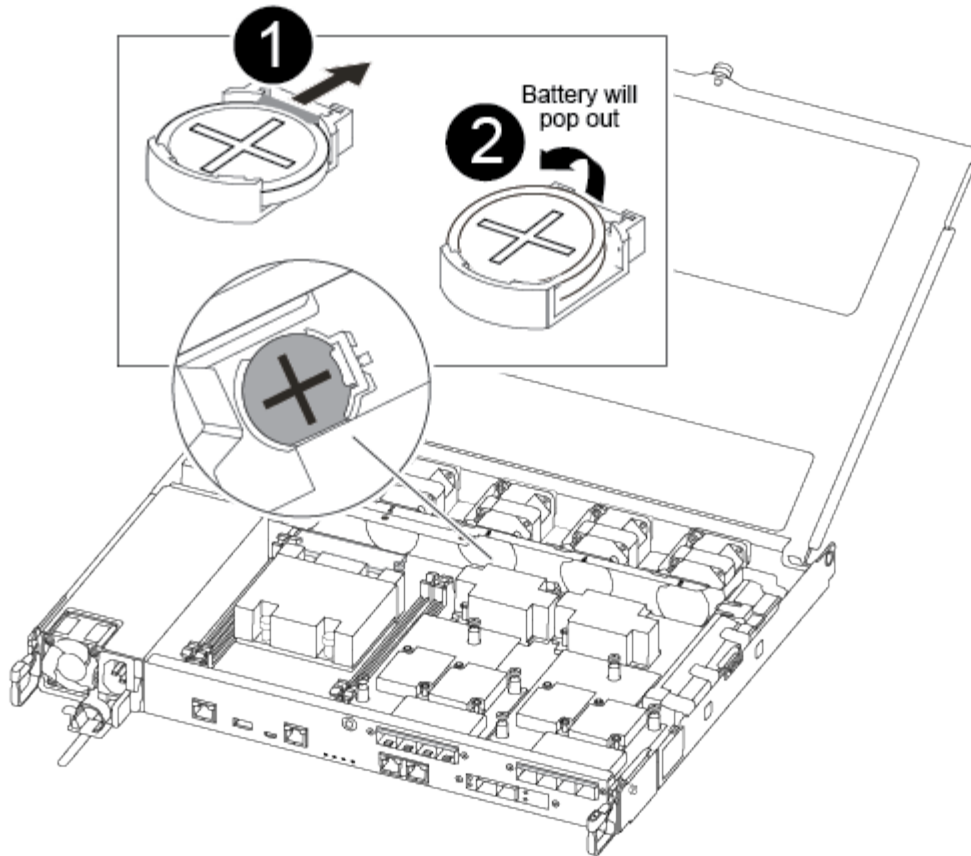



<p><b>1</b></p>	<p>Gently pull tab away from the battery housing.  <b>Attention:</b> Pulling it away aggressively might displace the tab.</p>
<p><b>2</b></p>	<p>Lift the battery up.  <b>Note:</b> Make a note of the polarity of the battery.</p>
<p><b>3</b></p>	<p>The battery should eject out.</p>

The battery will be ejected out.

2. Remove the replacement battery from the antistatic shipping bag.
3. Locate the RTC battery holder between the heatsink and the midplane and insert it exactly as shown in the graphic.

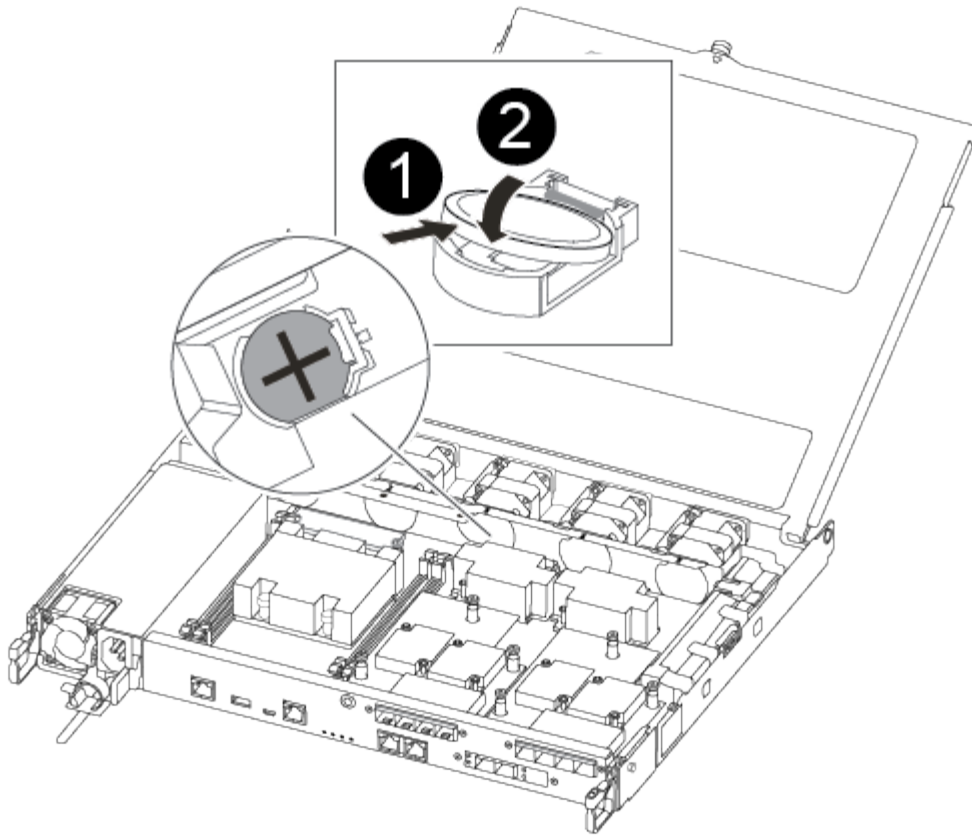



<p><b>1</b></p>	<p>With positive polarity face up, slide the battery under the tab of the battery housing.</p>
<p><b>2</b></p>	<p>Push the battery gently into place and make sure the tab secures it to the housing.</p> <p> Pushing it in aggressively might cause the battery to eject out again.</p>

4. Visually inspect the battery to make sure that it is completely installed into the holder and that the polarity is correct.

#### Step 4: Reinstall the controller module and setting time/date after RTC battery replacement

After you replace a component within the controller module, you must reinstall the controller module in the system chassis, reset the time and date on the controller, and then boot it.

1. If you have not already done so, close the air duct or controller module cover.
2. Align the end of the controller module with the opening in the chassis, and then gently push the controller module halfway into the system.

Do not completely insert the controller module in the chassis until instructed to do so.

3. Recable the system, as needed.

If you removed the media converters (QSFPs or SFPs), remember to reinstall them if you are using fiber

optic cables.

4. If the power supplies were unplugged, plug them back in and reinstall the power cable retainers.
5. Insert the controller module into the chassis:
  - a. Ensure the latching mechanism arms are locked in the fully extended position.
  - b. Using both hands, align and gently slide the controller module into the latching mechanism arms until it stops.
  - c. Place your index fingers through the finger holes from the inside of the latching mechanism.
  - d. Press your thumbs down on the orange tabs on top of the latching mechanism and gently push the controller module over the stop.
  - e. Release your thumbs from the top of the latching mechanisms and continue pushing until the latching mechanisms snap into place.

The controller module begins to boot as soon as it is fully seated in the chassis. Be prepared to interrupt the boot process.

- f. Halt the controller at the `LOADER` prompt.

The controller module should be fully inserted and flush with the edges of the chassis.

6. Reset the time and date on the controller:
  - a. Check the date and time on the healthy controller with the `show date` command.
  - b. At the `LOADER` prompt on the target controller, check the time and date.
  - c. If necessary, modify the date with the `set date mm/dd/yyyy` command.
  - d. If necessary, set the time, in GMT, using the `set time hh:mm:ss` command.
  - e. Confirm the date and time on the target controller.
7. At the `LOADER` prompt, enter `bye` to reinitialize the PCIe cards and other components and let the controller reboot.
8. Return the controller to normal operation by giving back its storage: `storage failover giveback -ofnode impaired_node_name`
9. If automatic giveback was disabled, reenable it: `storage failover modify -node local -auto -giveback true`

## Step 5: Return the failed part to NetApp

Return the failed part to NetApp, as described in the RMA instructions shipped with the kit. See the [Part Return and Replacements](#) page for further information.

## ASA C400 systems

### Install and setup

**Start here:** Choose your installation and setup experience

For most configurations, you can choose from different content formats.

- [Quick steps](#)

A printable PDF of step-by-step instructions with live links to additional content.

- [Video steps](#)

Video step-by-step instructions.

- [Detailed steps](#)

Online step-by-step instructions with live links to additional content.

For MetroCluster configurations, see either:

- [Install MetroCluster IP configuration](#)
- [Install MetroCluster Fabric-Attached configuration](#)

#### Quick guide - ASA C400

The quick guide provides graphic instructions for a typical installation of your system, from racking and cabling, through initial system bring-up. Use this procedure if you are familiar with installing NetApp systems.

Use the [AFF C400 Installation and Setup Instructions](#).



The ASA C400 uses the same installation procedure as the AFF C400 system.

#### Videos - ASA C400

The following video shows how to install and cable your new system.

[Animation - AFF C400 Installation and setup instructions](#)



The ASA C400 uses the same installation procedure as the AFF C400 system.

If you have a MetroCluster configuration, use the MetroCluster installation content.

[MetroCluster Documentation](#)

#### Detailed guide - ASA C400

This guide gives detailed step-by-step instructions for installing a typical NetApp system. Use this guide if you want more detailed installation instructions.

If you have a MetroCluster configuration, use the MetroCluster installation content.

[MetroCluster Documentation](#)

### Step 1: Prepare for installation

To install your system, you need to create an account, register the system, and get license keys. You also need to inventory the appropriate number and type of cables for your system and collect specific network information.

## Before you begin

- You need to have access to the Hardware Universe for information about site requirements as well as additional information on your configured system. You might also want to have access to the Release Notes for your version of ONTAP for more information about this system.

[NetApp Hardware Universe](#)

[Find the Release Notes for your version of ONTAP 9](#)

- You need to provide the following at your site:
  - Rack space for the storage system
  - Phillips #2 screwdriver
  - Additional networking cables to connect your system to your network switch and laptop or console with a Web browser

## Steps



1. Unpack the contents of all boxes.
2. Record the system serial number from the controllers.







3. Inventory and make a note of the number and types of cables you received.

The following table identifies the types of cables you might receive. If you receive a cable not listed in the table, see the Hardware Universe to locate the cable and identify its use.

[NetApp Hardware Universe](#)

Type of cable...	Part number and length	Connector type	For...
100 GbE cable (QSFP28)	X66211A-05 (112-00595), 0.5m X66211A-1 (112-00573), 1m X66211A-2 (112-00574), 2m X66211A-5 (112-00574), 5m		Storage, cluster interconnect/HA, and Ethernet data (order-dependent)
25 GbE cable (SFP28)	X66240-2 (112-00598), 2m X66240-5 (112-00639), 5m		GbE network connection (order-dependent)
32 Gb FC (SFP+ Op)	X66250-2 (112-00342), 2m X66250-5 (112-00344), 5m X66250-15 (112-00346), 15m		FC network connection

Type of cable...	Part number and length	Connector type	For...
Optical cables	X66250-2-N-C (112-00342)		16 Gb FC or 25GbE cables for mezzanine cards (order-dependent)
RJ-45 (order dependent)	X6585-R6 (112-00291), 3m X6562-R6 (112-00196), 5m		Management network
Micro-USB console cable	Not applicable		Console connection used during software setup if laptop or console does not support network discovery.
Power cables	Not applicable		Powering up the system

4. Review the *NetApp ONTAP Configuration Guide* and collect the required information listed in that guide.

[ONTAP Configuration Guide](#)

## Step 2: Install the hardware

You need to install your system in a 4-post rack or NetApp system cabinet, as applicable.

1. Install the rail kits, as needed.
2. Install and secure your system using the instructions included with the rail kit.



You need to be aware of the safety concerns associated with the weight of the system.

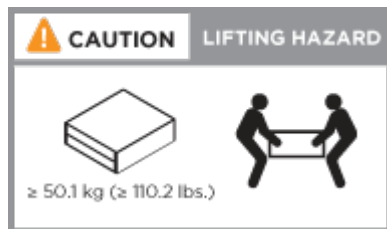

3. Attach cable management devices (as shown).

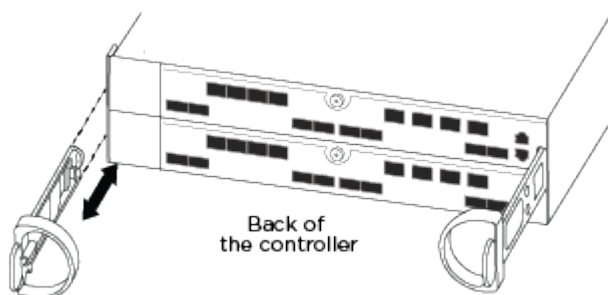

4. Place the bezel on the front of the system.

### **Step 3: Cable controllers to your network**

You can cable the controllers to your network by using the two-node switchless cluster method or by using the switched cluster method.

#### **About this task**

- If the port labels on the card are not visible, you can identify the ports by checking the card installation orientation (for C400, the PCIe connector socket is on the left side of the card slot), and then look for the card by part number in NetApp Hardware Universe, which shows a graphic of the bezel with the port labels. You can find the card part number using the `sysconfig -a` command or on the system packing list.
- If you are cabling an MetroCluster IP configuration, ports e0a/e0b are available for hosting data LIFs (usually in Default IPspace).

## Option 1: Cable a two-node switchless cluster

A controller module's cluster interconnect and HA ports are cabled to its partner controller module. The optional data ports, optional NIC cards, and management ports on the controller modules are connected to switches.

### Before you begin

You must have contacted your network administrator for information about connecting the system to the switches.

### About this task

Be sure to check the direction of the cable pull-tabs when inserting the cables in the ports. Cable pull-tabs are up for all onboard ports and down for expansion (NIC) cards.

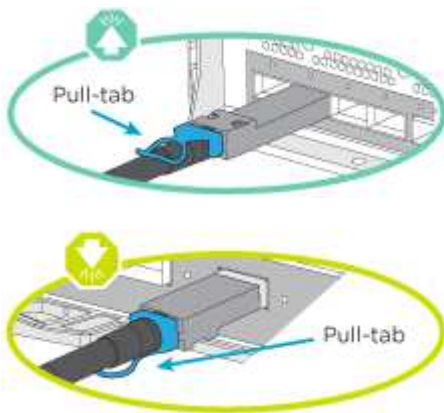

As you insert the connector, you should feel it click into place; if you do not feel it click, remove it, turn it around and try again.

### Steps

1. Use the illustration to complete the cabling between the controllers and the switches:

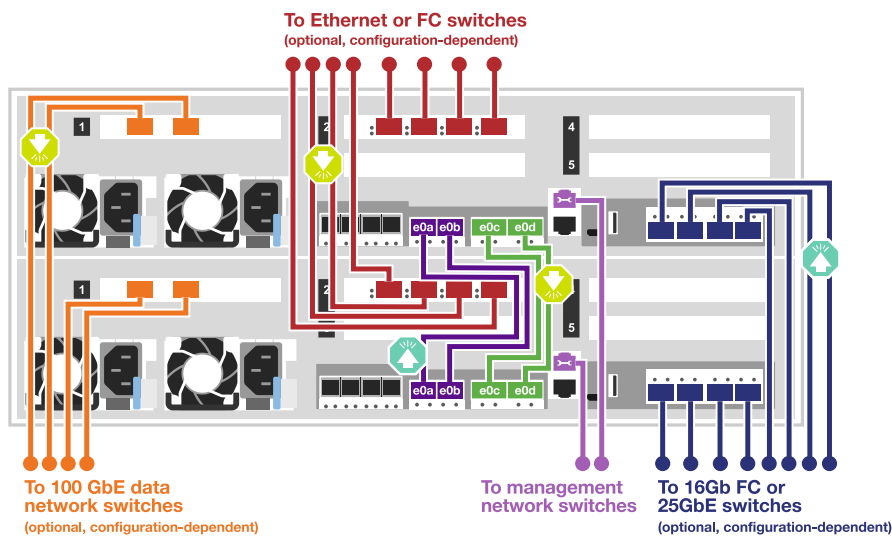

2. Go to [Step 4: Cable controllers to drive shelves](#) for drive shelf cabling instructions.

## Option 2: Cable a switched cluster

Controller module cluster interconnect and HA ports are cabled to the cluster/HA switch. The optional data ports, optional NIC cards, mezzanine cards, and management ports are connected to switches.

### Before you begin

You must have contacted your network administrator for information about connecting the system to the switches.

### About this task

Be sure to check the direction of the cable pull-tabs when inserting the cables in the ports. Cable pull-tabs are up for all onboard ports and down for expansion (NIC) cards.

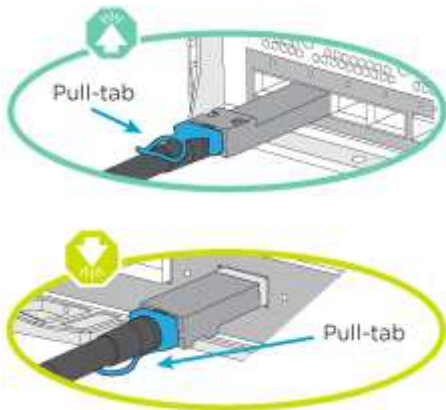

As you insert the connector, you should feel it click into place; if you do not feel it click, remove it, turn it around and try again.

### Steps

1. Use the illustration to complete the cabling between the controllers and the switches:

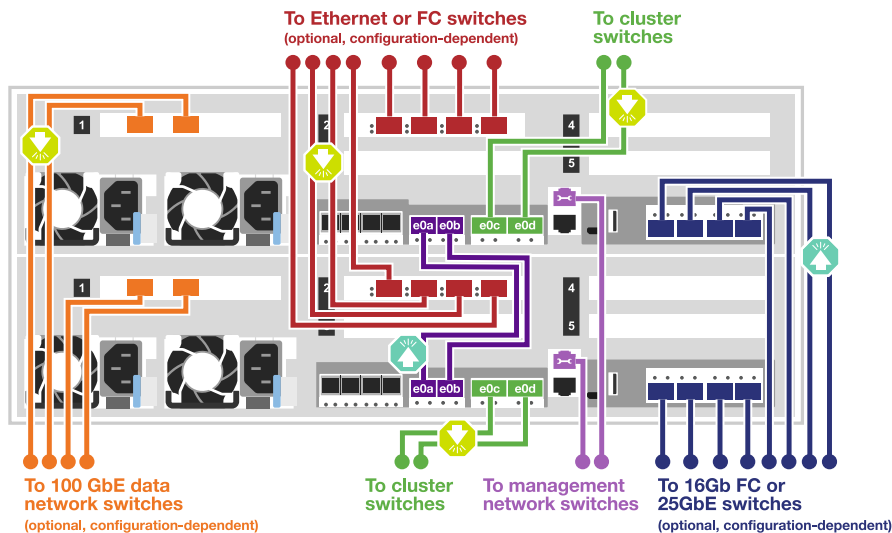

2. Go to [Step 4: Cable controllers to drive shelves](#) for drive shelf cabling instructions.

### Step 4: Cable controllers to drive shelves

The following options show you how to cable one or two NS224 drive shelves to your system.



## Option 1: Cable the controllers to a single drive shelf

You must cable each controller to the NSM modules on the NS224 drive shelf.

### About this task

Be sure to check the illustration arrow for the proper cable connector pull-tab orientation. The cable pull-tab for the NS224 are up.

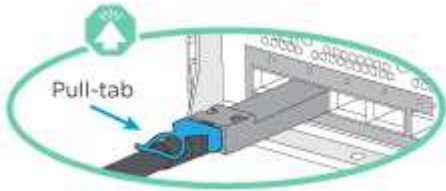

As you insert the connector, you should feel it click into place; if you do not feel it click, remove it, turn it around and try again.

### Steps

1. Use the following illustration to cable your controllers to a single drive shelf.

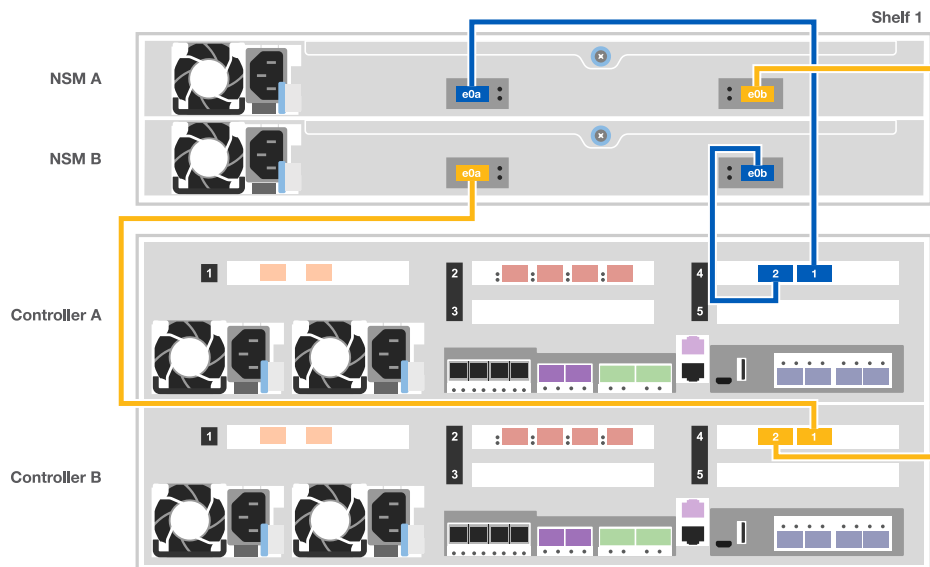

2. Go to [Step 5: Complete system setup and configuration](#) to complete system setup and configuration.

## Option 2: Cable the controllers to two drive shelves

You must cable each controller to the NSM modules on both NS224 drive shelves.

### About this task

Be sure to check the illustration arrow for the proper cable connector pull-tab orientation. The cable pull-tab for the NS224 are up.

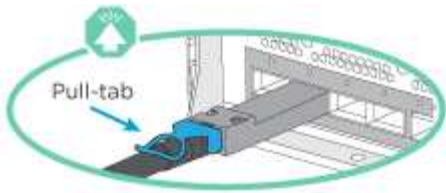

As you insert the connector, you should feel it click into place; if you do not feel it click, remove it, turn it around and try again.

## Steps

1. Use the following illustration to cable your controllers to two drive shelves.

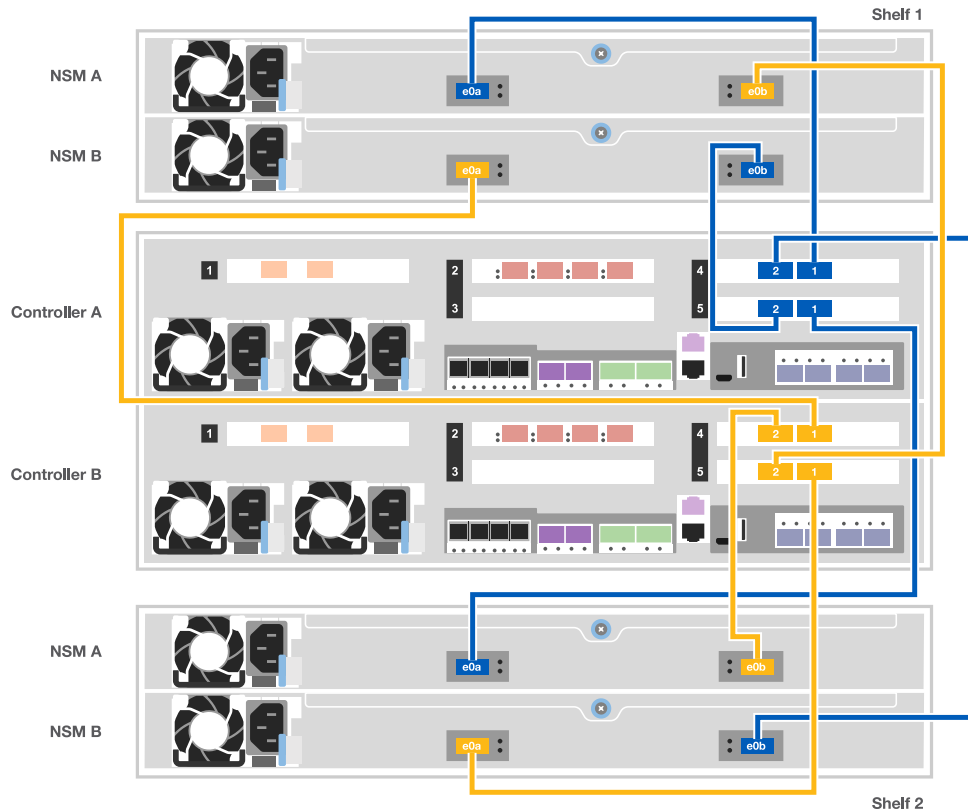

2. Go to [Step 5: Complete system setup and configuration](#) to complete system setup and configuration.

## Step 5: Complete system setup and configuration

You can complete the system setup and configuration using cluster discovery with only a connection to the switch and laptop, or by connecting directly to a controller in the system and then connecting to the management switch.

### Option 1: Completing system setup and configuration if network discovery is enabled

If you have network discovery enabled on your laptop, you can complete system setup and configuration using automatic cluster discovery.

1. Use the following animation to power on and set shelf IDs for one or more drive shelves:

For NS224 drive shelves, shelf IDs are pre-set to 00 and 01. If you want to change the shelf IDs, use the

straightened end of a paperclip, or narrow tipped ball point pen to access the shelf ID button behind the faceplate.

### Animation - Set drive shelf IDs

2. Plug the power cords into the controller power supplies, and then connect them to power sources on different circuits.
3. Make sure that your laptop has network discovery enabled.

See your laptop's online help for more information.

4. Connect your laptop to the Management switch.



1. Select an ONTAP icon listed to discover:

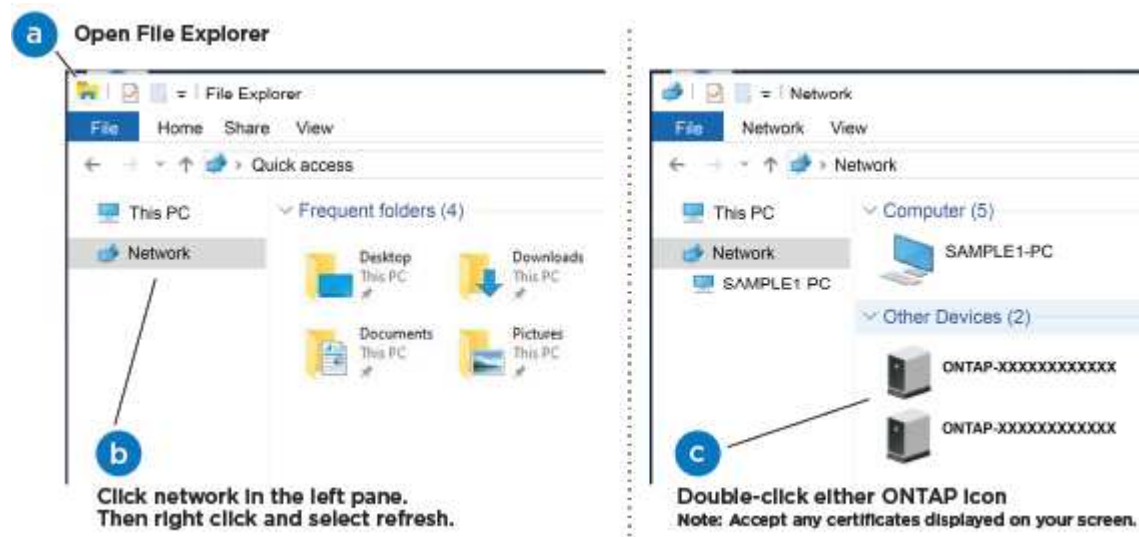

- a. Open File Explorer.
- b. Click network in the left pane.
- c. Right click and select refresh.
- d. Double-click either ONTAP icon and accept any certificates displayed on your screen.



XXXXX is the system serial number for the target node.

System Manager opens.

2. Use System Manager guided setup to configure your system using the data you collected in the *NetApp ONTAP Configuration Guide*.

### [ONTAP Configuration Guide](#)

3. Set up your account and download Active IQ Config Advisor:

- a. Log in to your existing account or create an account.

[NetApp Support Registration](#)

- b. Register your system.

[NetApp Product Registration](#)

- c. Download Active IQ Config Advisor.

[NetApp Downloads: Config Advisor](#)

4. Verify the health of your system by running Config Advisor.

5. After you have completed the initial configuration, go to the [ONTAP & ONTAP System Manager Documentation Resources](#) page for information about configuring additional features in ONTAP.

### Option 2: Completing system setup and configuration if network discovery is not enabled

If network discovery is not enabled on your laptop, you must complete the configuration and setup using this task.

1. Cable and configure your laptop or console:

- a. Set the console port on the laptop or console to 115,200 baud with N-8-1.



See your laptop or console's online help for how to configure the console port.

- b. Connect the console cable to the laptop or console using the console cable that came with your system, and then connect the laptop to the management switch on the management subnet .

- c. Assign a TCP/IP address to the laptop or console, using one that is on the management subnet.

2. Use the following animation to power on and set shelf IDs for one or more drive shelves:

For NS224 drive shelves, shelf IDs are pre-set to 00 and 01. If you want to change the shelf IDs, use the straightened end of a paperclip, or narrow tipped ball point pen to access the shelf ID button behind the faceplate.

[Animation - Set drive shelf IDs](#)

3. Plug the power cords into the controller power supplies, and then connect them to power sources on different circuits.



Initial booting may take up to eight minutes.

4. Assign an initial node management IP address to one of the nodes.

If the management network has DHCP...	Then...
Configured	Record the IP address assigned to the new controllers.

If the management network has DHCP...	Then...
Not configured	<p>a. Open a console session using PuTTY, a terminal server, or the equivalent for your environment.</p> <div style="display: flex; align-items: center; margin: 10px 0;">  <p>Check your laptop or console's online help if you do not know how to configure PuTTY.</p> </div> <p>b. Enter the management IP address when prompted by the script.</p>

5. Using System Manager on your laptop or console, configure your cluster:

a. Point your browser to the node management IP address.



The format for the address is `https://x.x.x.x`.

b. Configure the system using the data you collected in the *NetApp ONTAP Configuration guide*.

[ONTAP Configuration Guide](#)

6. Set up your account and download Active IQ Config Advisor:

a. Log in to your existing account or create an account.

[NetApp Support Registration](#)

b. Register your system.

[NetApp Product Registration](#)

c. Download Active IQ Config Advisor.

[NetApp Downloads: Config Advisor](#)

7. Verify the health of your system by running Config Advisor.

8. After you have completed the initial configuration, go to the [ONTAP & ONTAP System Manager Documentation Resources](#) page for information about configuring additional features in ONTAP.

## Maintain

### Maintain ASA C400 hardware

For the ASA C400 storage system, you can perform maintenance procedures on the following components.

### Boot media

The boot media stores a primary and secondary set of boot image files that the system uses when it boots.

### Chassis

The chassis is the physical enclosure housing all the controller components such as the controller/CPU unit,

power supply, and I/O.

## **Controller**

A controller consists of a board, firmware, and software. It controls the drives and implements the ONTAP functions.

## **DIMM**

You must replace a DIMM (dual in-line memory module) when a memory mismatch is present, or you have a failed DIMM.

## **Fan**

The fan cools the controller.

## **NVDIMM battery**

A NVDIMM battery is responsible for maintaining power to the NVDIMM module.

## **NVDIMM**

The NVDIMM (non-volatile dual in-line memory module) manages the data transfer from the volatile memory to the non-volatile storage, and maintains data integrity in the event of a power loss or system shutdown.

## **PCIe or Mezzanine card**

A PCIe (peripheral component interconnect express) card is an expansion card that plugs into the PCIe slot on the motherboard.

A Mezzanine card is an expansion card that is designed to be inserted into a specialized slot on the motherboard.

## **Power supply**

A power supply provides a redundant power source in a controller shelf.

## **Real time clock battery**

A real time clock battery preserves system date and time information if the power is off.

## **Boot media**

### **Overview of boot media replacement - ASA C400**

The boot media stores a primary and secondary set of system (boot image) files that the system uses when it boots. Depending on your network configuration, you can perform either a nondisruptive or disruptive replacement.

You must have a USB flash drive, formatted to FAT32, with the appropriate amount of storage to hold the

image\_xxx.tgz file.

You also must copy the `image_xxx.tgz` file to the USB flash drive for later use in this procedure.

- The nondisruptive and disruptive methods for replacing a boot media both require you to restore the `var` file system:
  - For nondisruptive replacement, the HA pair must be connected to a network to restore the `var` file system.
  - For disruptive replacement, you do not need a network connection to restore the `var` file system, but the process requires two reboots.
- You must replace the failed component with a replacement FRU component you received from your provider.
- It is important that you apply the commands in these steps on the correct node:
  - The *impaired* node is the node on which you are performing maintenance.
  - The *healthy node* is the HA partner of the impaired node.

### Check onboard encryption - ASA C400

Prior to shutting down the impaired controller and checking the status of the onboard encryption keys, you must check the status of the impaired controller, disable automatic giveback, and check which version of ONTAP is running on the system.

If you have a cluster with more than two nodes, it must be in quorum. If the cluster is not in quorum or a healthy controller shows false for eligibility and health, you must correct the issue before shutting down the impaired controller; see the [Synchronize a node with the cluster](#).

### Steps

1. Check the status of the impaired controller:
  - If the impaired controller is at the login prompt, log in as `admin`.
  - If the impaired controller is at the LOADER prompt and is part of HA configuration, log in as `admin` on the healthy controller.
  - If the impaired controller is in a standalone configuration and at LOADER prompt, contact [mysupport.netapp.com](https://mysupport.netapp.com).

2. If AutoSupport is enabled, suppress automatic case creation by invoking an AutoSupport message:

```
system node autosupport invoke -node * -type all -message  
MAINT=number_of_hours_downh
```

The following AutoSupport message suppresses automatic case creation for two hours: `cluster1:*>`  
`system node autosupport invoke -node * -type all -message MAINT=2h`

3. Check the version of ONTAP the system is running on the impaired controller if up, or on the partner controller if the impaired controller is down, using the `version -v` command:
  - If `<Ino-DARE>` or `<1Ono-DARE>` is displayed in the command output, the system does not support NVE, proceed to shut down the controller.
  - If `<Ino-DARE>` is not displayed in the command output, and the system is running ONTAP 9.6 or later, go to the next section.

4. If the impaired controller is part of an HA configuration, disable automatic giveback from the healthy controller: `storage failover modify -node local -auto-giveback false` or `storage failover modify -node local -auto-giveback-after-panic false`

### Check NVE or NSE on systems running ONTAP 9.6 and later

Before shutting down the impaired controller, you need to verify whether the system has either NetApp Volume Encryption (NVE) or NetApp Storage Encryption (NSE) enabled. If so, you need to verify the configuration.

1. Verify whether NVE is in use for any volumes in the cluster: `volume show -is-encrypted true`

If any volumes are listed in the output, NVE is configured and you need to verify the NVE configuration. If no volumes are listed, check whether NSE is configured and in use.

2. Verify whether NSE is configured and in use: `storage encryption disk show`
  - If the command output lists the drive details with Mode & Key ID information, NSE is configured and you need to verify the NSE configuration and in use.
  - If no disks are shown, NSE is not configured.
  - If NVE and NSE are not configured, no drives are protected with NSE keys, it's safe to shut down the impaired controller.

### Verify NVE configuration

1. Display the key IDs of the authentication keys that are stored on the key management servers: `security key-manager key query`



After the ONTAP 9.6 release, you may have additional key manager types. The types are KMIP, AKV, and GCP. The process for confirming these types is the same as confirming external or onboard key manager types.

- If the Key Manager type displays `external` and the Restored column displays `yes`, it's safe to shut down the impaired controller.
  - If the Key Manager type displays `onboard` and the Restored column displays `yes`, you need to complete some additional steps.
  - If the Key Manager type displays `external` and the Restored column displays anything other than `yes`, you need to complete some additional steps.
  - If the Key Manager type displays `onboard` and the Restored column displays anything other than `yes`, you need to complete some additional steps.
2. If the Key Manager type displays `onboard` and the Restored column displays `yes`, manually back up the OKM information:
    - a. Go to advanced privilege mode and enter `y` when prompted to continue: `set -priv advanced`
    - b. Enter the command to display the key management information: `security key-manager onboard show-backup`
    - c. Copy the contents of the backup information to a separate file or your log file. You'll need it in disaster scenarios where you might need to manually recover OKM.
    - d. Return to admin mode: `set -priv admin`



- e. Shut down the impaired controller.
3. If the `Key Manager` type displays `external` and the `Restored` column displays anything other than `yes`:
    - a. Restore the external key management authentication keys to all nodes in the cluster: `security key-manager external restore`

If the command fails, contact NetApp Support.

[mysupport.netapp.com](https://mysupport.netapp.com)

    - b. Verify that the `Restored` column equals `yes` for all authentication keys: `security key-manager key query`
    - c. Shut down the impaired controller.
  4. If the `Key Manager` type displays `onboard` and the `Restored` column displays anything other than `yes`:
    - a. Enter the onboard security key-manager sync command: `security key-manager onboard sync`



Enter the customer's 32 character, alphanumeric onboard key management passphrase at the prompt. If the passphrase cannot be provided, contact NetApp Support.

[mysupport.netapp.com](https://mysupport.netapp.com)

- b. Verify the `Restored` column shows `yes` for all authentication keys: `security key-manager key query`
- c. Verify that the `Key Manager` type shows `onboard`, and then manually back up the OKM information.
- d. Go to advanced privilege mode and enter `y` when prompted to continue: `set -priv advanced`
- e. Enter the command to display the key management backup information: `security key-manager onboard show-backup`
- f. Copy the contents of the backup information to a separate file or your log file. You'll need it in disaster scenarios where you might need to manually recover OKM.
- g. Return to admin mode: `set -priv admin`
- h. You can safely shut down the controller.

## Verify NSE configuration

1. Display the key IDs of the authentication keys that are stored on the key management servers: `security key-manager key query -key-type NSE-AK`



After the ONTAP 9.6 release, you may have additional key manager types. The types are `KMIP`, `AKV`, and `GCP`. The process for confirming these types is the same as confirming `external` or `onboard` key manager types.

- If the `Key Manager` type displays `external` and the `Restored` column displays `yes`, it's safe to shut down the impaired controller.
- If the `Key Manager` type displays `onboard` and the `Restored` column displays `yes`, you need to complete some additional steps.
- If the `Key Manager` type displays `external` and the `Restored` column displays anything other than

yes, you need to complete some additional steps.

- If the Key Manager type displays `external` and the Restored column displays anything other than `yes`, you need to complete some additional steps.

2. If the Key Manager type displays `onboard` and the Restored column displays `yes`, manually back up the OKM information:
  - a. Go to advanced privilege mode and enter `y` when prompted to continue: `set -priv advanced`
  - b. Enter the command to display the key management information: `security key-manager onboard show-backup`
  - c. Copy the contents of the backup information to a separate file or your log file. You'll need it in disaster scenarios where you might need to manually recover OKM.
  - d. Return to admin mode: `set -priv admin`
  - e. You can safely shut down the controller.
3. If the Key Manager type displays `external` and the Restored column displays anything other than `yes`:
  - a. Restore the external key management authentication keys to all nodes in the cluster: `security key-manager external restore`  
  
If the command fails, contact NetApp Support.  
  
[mysupport.netapp.com](https://mysupport.netapp.com)
  - b. Verify that the Restored column equals `yes` for all authentication keys: `security key-manager key query`
  - c. You can safely shut down the controller.
4. If the Key Manager type displays `onboard` and the Restored column displays anything other than `yes`:
  - a. Enter the onboard security key-manager sync command: `security key-manager onboard sync`  
  
Enter the customer's 32 character, alphanumeric onboard key management passphrase at the prompt. If the passphrase cannot be provided, contact NetApp Support.  
  
[mysupport.netapp.com](https://mysupport.netapp.com)
  - b. Verify the Restored column shows `yes` for all authentication keys: `security key-manager key query`
  - c. Verify that the Key Manager type shows `onboard`, and then manually back up the OKM information.
  - d. Go to advanced privilege mode and enter `y` when prompted to continue: `set -priv advanced`
  - e. Enter the command to display the key management backup information: `security key-manager onboard show-backup`
  - f. Copy the contents of the backup information to a separate file or your log file. You'll need it in disaster scenarios where you might need to manually recover OKM.
  - g. Return to admin mode: `set -priv admin`
  - h. You can safely shut down the controller.

## Shut down the impaired controller - ASA C400

After completing the NVE or NSE tasks, you need to complete the shutdown of the impaired controller. Shut down or take over the impaired controller using the appropriate procedure for your configuration.

### Option 1: Most configurations

After completing the NVE or NSE tasks, you need to complete the shutdown of the impaired controller.

#### Steps

- a. Take the impaired controller to the LOADER prompt:

If the impaired controller displays...	Then...
The LOADER prompt	Go to Remove controller module.
Waiting for giveback...	Press Ctrl-C, and then respond <code>y</code> when prompted.
System prompt or password prompt (enter system password)	Take over or halt the impaired controller from the healthy controller: <code>storage failover takeover -ofnode impaired_node_name</code>  When the impaired controller shows Waiting for giveback..., press Ctrl-C, and then respond <code>y</code> .

- b. From the LOADER prompt, enter: `printenv` to capture all boot environmental variables. Save the output to your log file.



This command may not work if the boot device is corrupted or non-functional.

### Option 2: Controller is in a MetroCluster configuration



Do not use this procedure if your system is in a two-node MetroCluster configuration.

To shut down the impaired controller, you must determine the status of the controller and, if necessary, take over the controller so that the healthy controller continues to serve data from the impaired controller storage.

- If you have a cluster with more than two nodes, it must be in quorum. If the cluster is not in quorum or a healthy controller shows false for eligibility and health, you must correct the issue before shutting down the impaired controller; see [Synchronize a node with the cluster](#).
- If you have a MetroCluster configuration, you must have confirmed that the MetroCluster Configuration State is configured and that the nodes are in an enabled and normal state (`metrocluster node show`).

#### Steps

1. If AutoSupport is enabled, suppress automatic case creation by invoking an AutoSupport message:  
`system node autosupport invoke -node * -type all -message  
MAINT=number_of_hours_downh`

The following AutoSupport message suppresses automatic case creation for two hours: `cluster1:*> system node autosupport invoke -node * -type all -message MAINT=2h`

2. Disable automatic giveback from the console of the healthy controller: `storage failover modify -node local -auto-giveback false`
3. Take the impaired controller to the LOADER prompt:

If the impaired controller is displaying...	Then...
The LOADER prompt	Go to the next step.
Waiting for giveback...	Press Ctrl-C, and then respond <code>y</code> when prompted.
System prompt or password prompt (enter system password)	Take over or halt the impaired controller from the healthy controller: <code>storage failover takeover -ofnode  impaired_node_name</code>  When the impaired controller shows Waiting for giveback..., press Ctrl-C, and then respond <code>y</code> .

### Option 3: Controller is in a two-node Metrocluster

To shut down the impaired controller, you must determine the status of the controller and, if necessary, switch over the controller so that the healthy controller continues to serve data from the impaired controller storage.

#### About this task

- You must leave the power supplies turned on at the end of this procedure to provide power to the healthy controller.

#### Steps

1. Check the MetroCluster status to determine whether the impaired controller has automatically switched over to the healthy controller: `metrocluster show`
2. Depending on whether an automatic switchover has occurred, proceed according to the following table:

If the impaired controller...	Then...
Has automatically switched over	Proceed to the next step.
Has not automatically switched over	Perform a planned switchover operation from the healthy controller: <code>metrocluster switchover</code>
Has not automatically switched over, you attempted switchover with the <code>metrocluster switchover</code> command, and the switchover was vetoed	Review the veto messages and, if possible, resolve the issue and try again. If you are unable to resolve the issue, contact technical support.

3. Resynchronize the data aggregates by running the `metrocluster heal -phase aggregates` command from the surviving cluster.

```
controller_A_1::> metrocluster heal -phase aggregates
[Job 130] Job succeeded: Heal Aggregates is successful.
```

If the healing is vetoed, you have the option of reissuing the `metrocluster heal` command with the `-override-vetoes` parameter. If you use this optional parameter, the system overrides any soft vetoes that prevent the healing operation.

4. Verify that the operation has been completed by using the `metrocluster operation show` command.

```
controller_A_1::> metrocluster operation show
Operation: heal-aggregates
State: successful
Start Time: 7/25/2016 18:45:55
End Time: 7/25/2016 18:45:56
Errors: -
```

5. Check the state of the aggregates by using the `storage aggregate show` command.

```
controller_A_1::> storage aggregate show
Aggregate      Size Available Used% State   #Vols  Nodes           RAID
Status
-----
...
aggr_b2       227.1GB   227.1GB   0% online    0 mcc1-a2
raid_dp, mirrored, normal...
```

6. Heal the root aggregates by using the `metrocluster heal -phase root-aggregates` command.

```
mcc1A::> metrocluster heal -phase root-aggregates
[Job 137] Job succeeded: Heal Root Aggregates is successful
```

If the healing is vetoed, you have the option of reissuing the `metrocluster heal` command with the `-override-vetoes` parameter. If you use this optional parameter, the system overrides any soft vetoes that prevent the healing operation.

7. Verify that the heal operation is complete by using the `metrocluster operation show` command on the destination cluster:

```
mccl1A::> metrocluster operation show
Operation: heal-root-aggregates
State: successful
Start Time: 7/29/2016 20:54:41
End Time: 7/29/2016 20:54:42
Errors: -
```

8. On the impaired controller module, disconnect the power supplies.

### Replace the boot media - ASA C400

To replace the boot media, you must remove the impaired controller module, install the replacement boot media, and transfer the boot image to a USB flash drive.

#### Step 1: Remove the controller module

To access components inside the controller module, you must remove the controller module from the chassis.

##### Steps

1. If you are not already grounded, properly ground yourself.
2. Release the power cable retainers, and then unplug the cables from the power supplies.
3. Loosen the hook and loop strap binding the cables to the cable management device, and then unplug the system cables and SFPs (if needed) from the controller module, keeping track of where the cables were connected.

Leave the cables in the cable management device so that when you reinstall the cable management device, the cables are organized.

4. Remove the cable management device from the controller module and set it aside.
5. Press down on both of the locking latches, and then rotate both latches downward at the same time.

The controller module moves slightly out of the chassis.

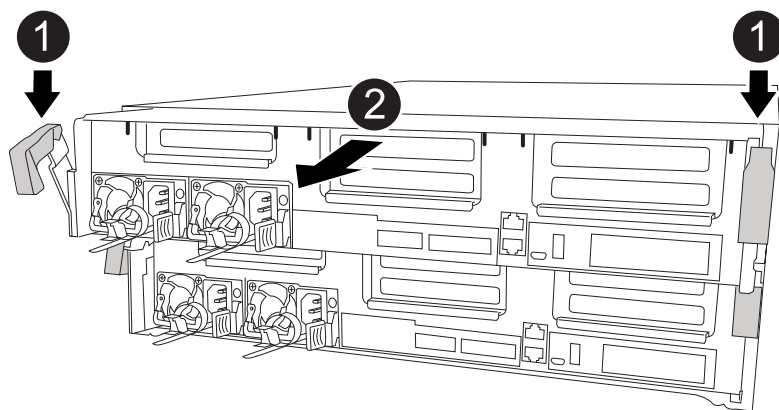

<b>1</b>	Locking latches
----------	-----------------

2

Controller moves slightly out of chassis

6. Slide the controller module out of the chassis.

Make sure that you support the bottom of the controller module as you slide it out of the chassis.

7. Place the controller module on a stable, flat surface.

## Step 2: Replace the boot media

You must locate the boot media in the controller module (see the FRU map on the controller module), and then follow the directions to replace it.

### Before you begin

Although the contents of the boot media is encrypted, it is a best practice to erase the contents of the boot media before replacing it. For more information, see the [Statement of Volatility](#) for your system on the NetApp Support Site.



You must log into the NetApp Support Site to display the *Statement of Volatility* for your system.

You can use the following animation, illustration, or the written steps to replace the boot media.

### Animation - Replace the boot media

#### Steps

1. Open the air duct:

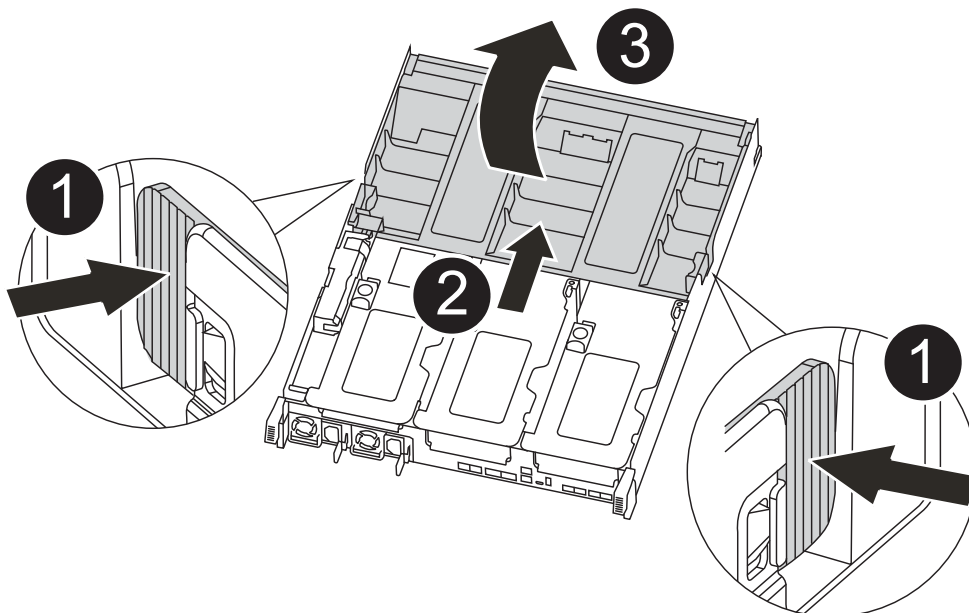

1

Locking tabs

<b>2</b>	Slide air duct toward back of controller
<b>3</b>	Rotate air duct up

- a. Press the locking tabs on the sides of the air duct in toward the middle of the controller module.
- b. Slide the air duct toward the back of the controller module, and then rotate it upward to its completely open position.

2. Locate and remove the boot media from the controller module:

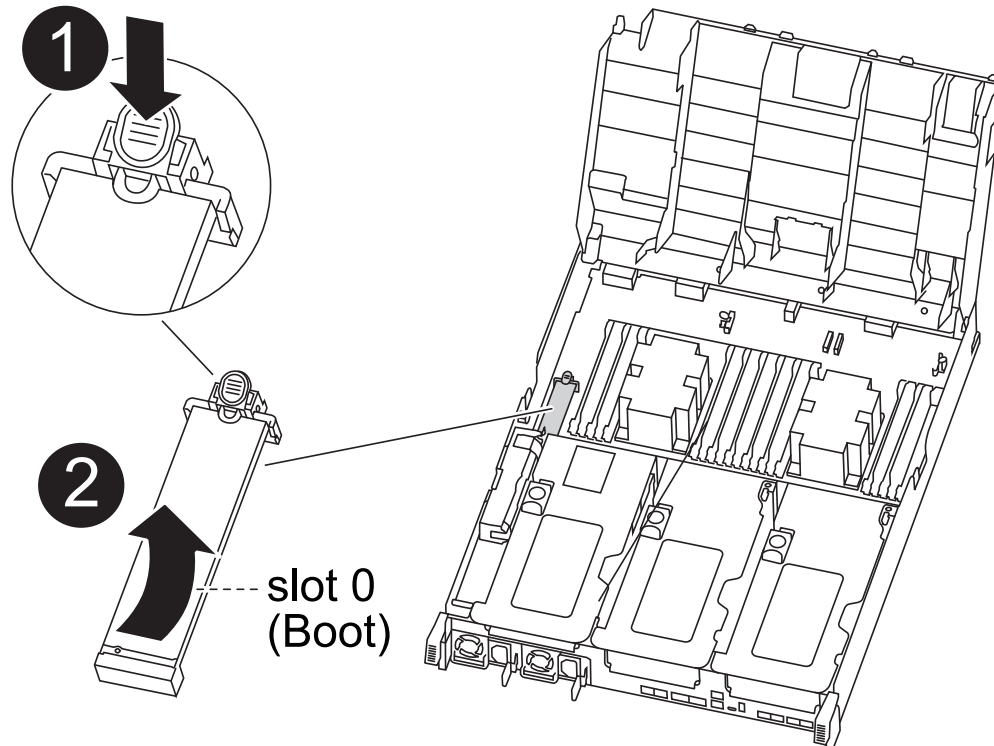

<b>1</b>	Press blue button
<b>2</b>	Rotate boot media up and remove from socket

- a. Press the blue button at the end of the boot media until the lip on the boot media clears the blue button.
  - b. Rotate the boot media up and gently pull the boot media out of the socket.
3. Align the edges of the replacement boot media with the boot media socket, and then gently push it into the socket.
  4. Check the boot media to make sure that it is seated squarely and completely in the socket.

If necessary, remove the boot media and reseal it into the socket.

5. Lock the boot media in place:
  - a. Rotate the boot media down toward the motherboard.



- b. Placing a finger at the end of the boot media by the blue button, push down on the boot media end to engage the blue locking button.
  - c. While pushing down on the boot media, lift the blue locking button to lock the boot media in place.
6. Close the air duct.

### Step 3: Transfer the boot image to the boot media

The replacement boot media that you installed does not have a boot image, so you need to transfer a boot image using a USB flash drive.

#### Before you begin

- You must have a USB flash drive, formatted to MBR/FAT32, with at least 4GB capacity
- A copy of the same image version of ONTAP as what the impaired controller was running. You can download the appropriate image from the Downloads section on the NetApp Support Site
  - If NVE is enabled, download the image with NetApp Volume Encryption, as indicated in the download button.
  - If NVE is not enabled, download the image without NetApp Volume Encryption, as indicated in the download button.
- If your system is an HA pair, you must have a network connection.
- If your system is a stand-alone system you do not need a network connection, but you must perform an additional reboot when restoring the `var` file system.

#### Steps

1. Download and copy the appropriate service image from the NetApp Support Site to the USB flash drive.
  - a. Download the service image to your work space on your laptop.
  - b. Unzip the service image.



If you are extracting the contents using Windows, do not use WinZip to extract the netboot image. Use another extraction tool, such as 7-Zip or WinRAR.

There are two folders in the unzipped service image file:

- `boot`
- `efi`

- c. Copy the `efi` folder to the top directory on the USB flash drive.

The USB flash drive should have the `efi` folder and the same Service Image (BIOS) version of what the impaired controller is running.

- d. Remove the USB flash drive from your laptop.
2. If you have not already done so, close the air duct.
3. Align the end of the controller module with the opening in the chassis, and then gently push the controller module halfway into the system.
4. Reinstall the cable management device and recable the system, as needed.

When recabling, remember to reinstall the media converters (SFPs or QSFPs) if they were removed.

5. Plug the power cable into the power supply and reinstall the power cable retainer.
6. Insert the USB flash drive into the USB slot on the controller module.

Make sure that you install the USB flash drive in the slot labeled for USB devices, and not in the USB console port.

7. Complete the installation of the controller module:
  - a. Plug the power cord into the power supply, reinstall the power cable locking collar, and then connect the power supply to the power source.
  - b. Firmly push the controller module into the chassis until it meets the midplane and is fully seated.

The locking latches rise when the controller module is fully seated.



Do not use excessive force when sliding the controller module into the chassis to avoid damaging the connectors.

The controller module begins to boot as soon as it is fully seated in the chassis. Be prepared to interrupt the boot process.

- c. Rotate the locking latches upward, tilting them so that they clear the locking pins, and then lower them into the locked position.
  - d. If you have not already done so, reinstall the cable management device.
8. Interrupt the boot process by pressing Ctrl-C to stop at the LOADER prompt.

If you miss this message, press Ctrl-C, select the option to boot to Maintenance mode, and then `halt` the controller to boot to LOADER.

9. If the controller is in a stretch or fabric-attached MetroCluster, you must restore the FC adapter configuration:
  - a. Boot to Maintenance mode: `boot_ontap maint`
  - b. Set the MetroCluster ports as initiators: `ucadmin modify -m fc -t initiator adapter_name`
  - c. Halt to return to Maintenance mode: `halt`

The changes will be implemented when the system is booted.

## Boot the recovery image - ASA C400

The procedure for booting the impaired controller from the recovery image depends on whether the system is in a two-node MetroCluster configuration.

### Option 1: Most systems

You must boot the ONTAP image from the USB drive, restore the file system, and verify the environmental variables.

This procedure applies to systems that are not in a two-node MetroCluster configuration.

### Steps

1. From the LOADER prompt, boot the recovery image from the USB flash drive: `boot_recovery`

The image is downloaded from the USB flash drive.

2. When prompted, either enter the name of the image or accept the default image displayed inside the brackets on your screen.
3. Restore the `var` file system:

If your system has...	Then...
A network connection	<ol style="list-style-type: none"> <li>a. Press <code>y</code> when prompted to restore the backup configuration.</li> <li>b. Set the healthy controller to advanced privilege level: <code>set -privilege advanced</code></li> <li>c. Run the restore backup command: <code>system node restore-backup -node local -target-address <i>impaired_node_IP_address</i></code></li> <li>d. Return the controller to admin level: <code>set -privilege admin</code></li> <li>e. Press <code>y</code> when prompted to use the restored configuration.</li> <li>f. Press <code>y</code> when prompted to reboot the controller.</li> </ol>
No network connection	<ol style="list-style-type: none"> <li>a. Press <code>n</code> when prompted to restore the backup configuration.</li> <li>b. Reboot the system when prompted by the system.</li> <li>c. Select the <b>Update flash from backup config</b> (sync flash) option from the displayed menu.</li> </ol> <p>If you are prompted to continue with the update, press <code>y</code>.</p>

4. Ensure that the environmental variables are set as expected:
  - a. Take the controller to the LOADER prompt.
  - b. Check the environment variable settings with the `printenv` command.
  - c. If an environment variable is not set as expected, modify it with the `setenv environment-variable-name changed-value` command.
  - d. Save your changes using the `savenv` command.
5. The next depends on your system configuration:
  - If your system has onboard keymanager, NSE or NVE configured, go to [Restore OKM, NSE, and NVE as needed](#)
  - If your system does not have onboard keymanager, NSE or NVE configured, complete the steps in this section.
6. From the LOADER prompt, enter the `boot_ontap` command.

*If you see...	Then...*
The login prompt	Go to the next Step.

*If you see...	Then...*
Waiting for giveback...	<ol style="list-style-type: none"> <li>a. Log into the partner controller.</li> <li>b. Confirm the target controller is ready for giveback with the <code>storage failover show</code> command.</li> </ol>

7. Connect the console cable to the partner controller.
8. Give back the controller using the `storage failover giveback -fromnode local` command.
9. At the cluster prompt, check the logical interfaces with the `net int -is-home false` command.

If any interfaces are listed as "false", revert those interfaces back to their home port using the `net int revert` command.

10. Move the console cable to the repaired controller and run the `version -v` command to check the ONTAP versions.
11. Restore automatic giveback if you disabled it by using the `storage failover modify -node local -auto-giveback true` command.

## Option 2: Controller is in a two-node MetroCluster

You must boot the ONTAP image from the USB drive and verify the environmental variables.

This procedure applies to systems in a two-node MetroCluster configuration.

### Steps

1. From the LOADER prompt, boot the recovery image from the USB flash drive: `boot_recovery`

The image is downloaded from the USB flash drive.

2. When prompted, either enter the name of the image or accept the default image displayed inside the brackets on your screen.
3. After the image is installed, start the restoration process:
  - a. Press `n` when prompted to restore the backup configuration.
  - b. Press `y` when prompted to reboot to start using the newly installed software.

You should be prepared to interrupt the boot process when prompted.

4. As the system boots, press `Ctrl-C` after you see the `Press Ctrl-C for Boot Menu message.`, and when the Boot Menu is displayed select option 6.
5. Verify that the environmental variables are set as expected.
  - a. Take the node to the LOADER prompt.
  - b. Check the environment variable settings with the `printenv` command.
  - c. If an environment variable is not set as expected, modify it with the `setenv environment-variable-name changed-value` command.
  - d. Save your changes using the `savenv` command.

- e. Reboot the node.

### Switch back aggregates in a two-node MetroCluster configuration - ASA C400

After you have completed the FRU replacement in a two-node MetroCluster configuration, you can perform the MetroCluster switchback operation. This returns the configuration to its normal operating state, with the sync-source storage virtual machines (SVMs) on the formerly impaired site now active and serving data from the local disk pools.

This task only applies to two-node MetroCluster configurations.

#### Steps

1. Verify that all nodes are in the enabled state: `metrocluster node show`

```
cluster_B::> metrocluster node show

DR                               Configuration  DR
Group Cluster Node              State          Mirroring Mode
-----
1      cluster_A
      controller_A_1 configured      enabled   heal roots
completed
      cluster_B
      controller_B_1 configured      enabled   waiting for
switchback recovery
2 entries were displayed.
```

2. Verify that resynchronization is complete on all SVMs: `metrocluster vserver show`
3. Verify that any automatic LIF migrations being performed by the healing operations were completed successfully: `metrocluster check lif show`
4. Perform the switchback by using the `metrocluster switchback` command from any node in the surviving cluster.
5. Verify that the switchback operation has completed: `metrocluster show`

The switchback operation is still running when a cluster is in the `waiting-for-switchback` state:

```
cluster_B::> metrocluster show
Cluster              Configuration State      Mode
-----
Local: cluster_B configured      switchover
Remote: cluster_A configured      waiting-for-switchback
```

The switchback operation is complete when the clusters are in the `normal` state.:

```
cluster_B::> metrocluster show
Cluster                Configuration State      Mode
-----
Local: cluster_B configured      normal
Remote: cluster_A configured     normal
```

If a switchback is taking a long time to finish, you can check on the status of in-progress baselines by using the `metrocluster config-replication resync-status show` command.

6. Reestablish any SnapMirror or SnapVault configurations.

### Restore OKM, NSE, and NVE as needed - ASA C400

Once environment variables are checked, you must complete steps specific to systems that have Onboard Key Manager (OKM), NetApp Storage Encryption (NSE) or NetApp Volume Encryption (NVE) enabled.

1. Determine which section you should use to restore your OKM, NSE, or NVE configurations: If NSE or NVE are enabled along with Onboard Key Manager you must restore settings you captured at the beginning of this procedure.
  - If NSE or NVE are enabled and Onboard Key Manager is enabled, go to [Restore NVE or NSE when Onboard Key Manager is enabled](#).
  - If NSE or NVE are enabled for ONTAP 9.6, go to [Restore NSE/NVE on systems running ONTAP 9.6 and later](#).

### Restore NVE or NSE when Onboard Key Manager is enabled

#### Steps

1. Connect the console cable to the target controller.
2. Use the `boot_ontap` command at the LOADER prompt to boot the controller.
3. Check the console output:

If the console displays...	Then...
The LOADER prompt	Boot the controller to the boot menu: <code>boot_ontap menu</code>
Waiting for giveback....	<ol style="list-style-type: none"><li>a. Enter <code>Ctrl-C</code> at the prompt</li><li>b. At the message: Do you wish to halt this node rather than wait [y/n]? , enter: <code>y</code></li><li>c. At the LOADER prompt, enter the <code>boot_ontap menu</code> command.</li></ol>

4. At the Boot Menu, enter the hidden command, `recover_onboard_keymanager` and reply `y` at the prompt

5. Enter the passphrase for the onboard key manager you obtained from the customer at the beginning of this procedure.
6. When prompted to enter the backup data, paste the backup data you captured at the beginning of this procedure, when asked. Paste the output of `security key-manager backup show` OR `security key-manager onboard show-backup` command



The data is output from either `security key-manager backup show` or `security key-manager onboard show-backup` command.

Example of backup data:

```
-----BEGIN BACKUP-----
TmV0QXBwIEtleSBCbG9iAAEAAAAEAAAAcAEAAAAAADuD+byAAAAACEAAAAAAAA
QAAAAAAAAABvOIH0AAAAAMh7qDLRyH1DBz12piVdy9ATSFMT0C0TIYFss4PDjTaV
dzRYkLd1PhQLxAWJwOlyqSr8qY1SEBgm1IWgE5DLRqkiAAAAAAAAACgAAAAAAAA
3WTh7gAAAAAAAAAAAAAAAAIAAAAAAgAZJEIWvdeHr5RCAvHGclo+wAAAAAAAA
lgAAAAAAAAAoAAAAAAAAEOTcR0AAAAAAAAAAAAAAAACAAAAAAJAGr3tJA/
LRzUQRHwv+1aWvAAAAAAAAAACQAAAAAAAAAgAAAAAAAAACdhTcvAAAAAJ1PXeBf
ml4NBsSyV1B4jc4A7cvWEFY6ILG6hc6tbKLAHZuvfQ4rlbYAAAAAAAAAAAAAAAA
AAAAAAAAAAAAAAAAAAAAAAAAAAAAAAAAAAAAAAAAAAAAAAAAAAAAAAAAAAAAAA
AAAAAAAAAAAAAAAAAAAAAAAAAAAAAAAAAAAAAAAAAAAAAAAAAAAAAAAAAAAAAA
.
.
.
.
H4nPQM0nrDRYRa9SCv8AAAAAAAAAAAAAAAAAAAAAAAAAAAAAAAAAAAAAAAAAAAA
AAAAAAAAAAAAAAAAAAAAAAAAAAAAAAAAAAAAAAAAAAAAAAAAAAAAAAAAAAAAAA
AAAAAAAA
-----END BACKUP-----
```

7. At the Boot Menu select the option for Normal Boot.  
The system boots to Waiting for giveback... prompt.
8. Confirm the target controller is ready for giveback with the `storage failover show` command.
9. Giveback only the CFO aggregates with the `storage failover giveback -fromnode local -only-cfo-aggregates true` command.
  - If the command fails because of a failed disk, physically disengage the failed disk, but leave the disk in the slot until a replacement is received.
  - If the command fails because of an open CIFS sessions, check with customer how to close out CIFS sessions.



Terminating CIFS can cause loss of data.

- If the command fails because the partner "not ready", wait 5 minutes for the NVMEMs to synchronize.
- If the command fails because of an NDMP, SnapMirror, or SnapVault process, disable the process. See the appropriate Documentation Center for more information.

10. Once the giveback completes, check the failover and giveback status with the `storage failover show` and ``storage failover show-giveback`` commands.

Only the CFO aggregates (root aggregate and CFO style data aggregates) will be shown.

11. Move the console cable to the target controller.
  - a. If you are running ONTAP 9.6 or later, run the security key-manager onboard sync:
  - b. Run the `security key-manager onboard sync` command and then enter the passphrase when prompted.
  - c. Enter the `security key-manager key query` command to see a detailed view of all keys stored in the onboard key manager and verify that the `Restored` column = `yes/true` for all authentication keys.



If the `Restored` column = anything other than `yes/true`, contact Customer Support.

- d. Wait 10 minutes for the key to synchronize across the cluster.
12. Move the console cable to the partner controller.
13. Give back the target controller using the `storage failover giveback -fromnode local` command.
14. Check the giveback status, 3 minutes after it reports complete, using the `storage failover show` command.

If giveback is not complete after 20 minutes, contact Customer Support.

15. At the clustershell prompt, enter the `net int show -is-home false` command to list the logical interfaces that are not on their home controller and port.

If any interfaces are listed as `false`, revert those interfaces back to their home port using the `net int revert -vserver Cluster -lif nodename` command.

16. Move the console cable to the target controller and run the `version -v` command to check the ONTAP versions.
17. Restore automatic giveback if you disabled it by using the `storage failover modify -node local -auto-giveback true` command.

## Restore NSE/NVE on systems running ONTAP 9.6 and later

### Steps

1. Connect the console cable to the target controller.
2. Use the `boot_ontap` command at the LOADER prompt to boot the controller.
3. Check the console output:

If the console displays...	Then...
The login prompt	Go to Step 7.



Waiting for giveback...

- a. Log into the partner controller.
- b. Confirm the target controller is ready for giveback with the `storage failover show` command.

4. Move the console cable to the partner controller and give back the target controller storage using the `storage failover giveback -fromnode local -only-cfo-aggregates true local` command.
  - If the command fails because of a failed disk, physically disengage the failed disk, but leave the disk in the slot until a replacement is received.
  - If the command fails because of an open CIFS sessions, check with customer how to close out CIFS sessions.



Terminating CIFS can cause loss of data.

- If the command fails because the partner "not ready", wait 5 minutes for the NVMEMs to synchronize.
  - If the command fails because of an NDMP, SnapMirror, or SnapVault process, disable the process. See the appropriate Documentation Center for more information.
5. Wait 3 minutes and check the failover status with the `storage failover show` command.
  6. At the clustershell prompt, enter the `net int show -is-home false` command to list the logical interfaces that are not on their home controller and port.

If any interfaces are listed as `false`, revert those interfaces back to their home port using the `net int revert -vserver Cluster -lif nodename` command.

7. Move the console cable to the target controller and run the `version -v` command to check the ONTAP versions.
8. Restore automatic giveback if you disabled it by using the `storage failover modify -node local -auto-giveback true` command.
9. Use the `storage encryption disk show` at the clustershell prompt, to review the output.
10. Use the `security key-manager key query` command to display the key IDs of the authentication keys that are stored on the key management servers.
  - If the `Restored` column = `yes/true`, you are done and can proceed to complete the replacement process.
  - If the `Key Manager type` = `external` and the `Restored` column = anything other than `yes/true`, use the `security key-manager external restore` command to restore the key IDs of the authentication keys.



If the command fails, contact Customer Support.

- If the `Key Manager type` = `onboard` and the `Restored` column = anything other than `yes/true`, use the `security key-manager onboard sync` command to re-sync the Key Manager type.

Use the `security key-manager key query` command to verify that the `Restored` column = `yes/true` for all authentication keys.

11. Connect the console cable to the partner controller.
12. Give back the controller using the `storage failover giveback -fromnode local` command.
13. Restore automatic giveback if you disabled it by using the `storage failover modify -node local -auto-giveback true` command.

## Return the failed part to NetApp - ASA C400

Return the failed part to NetApp, as described in the RMA instructions shipped with the kit. See the [Part Return and Replacements](#) page for further information.

### Chassis

#### Overview of chassis replacement - ASA C400

To replace the chassis, you must move the fans and controller modules from the impaired chassis to the new chassis of the same model as the impaired chassis.

All other components in the system must be functioning properly; if not, you must contact technical support.

- You can use this procedure with all versions of ONTAP supported by your system.
- This procedure is disruptive. For a two-node cluster, you will have a complete service outage and a partial outage in a multinode cluster.

#### Shut down the controllers - ASA C400

Shut down or take over the impaired controller using the appropriate procedure for your configuration.

#### Option 1: Shut down the controllers when replacing a chassis

This procedure is for 2-node, non-MetroCluster configurations only. If you have a system with more than two nodes, see [How to perform a graceful shutdown and power up of one HA pair in a 4-node cluster](#).

#### Before you begin

You need:

- Local administrator credentials for ONTAP.
- NetApp onboard key management (OKM) cluster-wide passphrase if using storage encryption or NVE/NAE.
- BMC accessibility for each controller.
- Stop all clients/host from accessing data on the NetApp system.
- Suspend external backup jobs.
- Necessary tools and equipment for the replacement.



If the system is a NetApp StorageGRID or ONTAP S3 used as FabricPool cloud tier, refer to the [Gracefully shutdown and power up your storage system Resolution Guide](#) after performing this procedure.



If using SSDs, refer to [SU490: \(Impact: Critical\) SSD Best Practices: Avoid risk of drive failure and data loss if powered off for more than two months](#)

As a best practice before shutdown, you should:

- Perform additional [system health checks](#).
- Upgrade ONTAP to a recommended release for the system.
- Resolve any [Active IQ Wellness Alerts and Risks](#).  
Make note of any faults presently on the system, such as LEDs on the system components.

### Steps

1. Log into the cluster through SSH or log in from any node in the cluster using a local console cable and a laptop/console.
2. Turn off AutoSupport and indicate how long you expect the system to be offline:

```
system node autosupport invoke -node * -type all -message "MAINT=8h Power Maintenance"
```

3. Identify the SP/BMC address of all nodes:

```
system service-processor show -node * -fields address
```

4. Exit the cluster shell: `exit`
5. Log into SP/BMC over SSH using the IP address of any of the nodes listed in the output from the previous step.

If you're using a console/laptop, log into the controller using the same cluster administrator credentials.



Open an SSH session to every SP/BMC connection so that you can monitor progress.

6. Halt the 2 nodes located in the impaired chassis:

```
system node halt -node <node>,<node2> -skip-lif-migration-before-shutdown true -ignore-quorum-warnings true -inhibit-takeover true
```



For clusters using SnapMirror synchronous operating in StrictSync mode: `system node halt -node <node>,<node2> -skip-lif-migration-before-shutdown true -ignore-quorum-warnings true -inhibit-takeover true -ignore-strict-sync-warnings true`

7. Enter **y** for each controller in the cluster when you see *Warning: Are you sure you want to halt node "cluster <node-name> number"?*  
{y|n}:
8. Wait for each controller to halt and display the LOADER prompt.

### Option 2: Shut down a controller in a two-node MetroCluster configuration

To shut down the impaired controller, you must determine the status of the controller and, if necessary, switch over the controller so that the healthy controller continues to serve data from the impaired controller storage.

## About this task

- You must leave the power supplies turned on at the end of this procedure to provide power to the healthy controller.

## Steps

1. Check the MetroCluster status to determine whether the impaired controller has automatically switched over to the healthy controller: `metrocluster show`
2. Depending on whether an automatic switchover has occurred, proceed according to the following table:

If the impaired controller...	Then...
Has automatically switched over	Proceed to the next step.
Has not automatically switched over	Perform a planned switchover operation from the healthy controller: <code>metrocluster switchover</code>
Has not automatically switched over, you attempted switchover with the <code>metrocluster switchover</code> command, and the switchover was vetoed	Review the veto messages and, if possible, resolve the issue and try again. If you are unable to resolve the issue, contact technical support.

3. Resynchronize the data aggregates by running the `metrocluster heal -phase aggregates` command from the surviving cluster.

```
controller_A_1::> metrocluster heal -phase aggregates
[Job 130] Job succeeded: Heal Aggregates is successful.
```

If the healing is vetoed, you have the option of reissuing the `metrocluster heal` command with the `-override-vetoes` parameter. If you use this optional parameter, the system overrides any soft vetoes that prevent the healing operation.

4. Verify that the operation has been completed by using the `metrocluster operation show` command.

```
controller_A_1::> metrocluster operation show
  Operation: heal-aggregates
  State: successful
Start Time: 7/25/2016 18:45:55
  End Time: 7/25/2016 18:45:56
  Errors: -
```

5. Check the state of the aggregates by using the `storage aggregate show` command.

```

controller_A_1::> storage aggregate show
Aggregate      Size Available Used% State   #Vols  Nodes           RAID
Status
-----
...
aggr_b2       227.1GB   227.1GB   0% online    0 mcc1-a2
raid_dp, mirrored, normal...

```

6. Heal the root aggregates by using the `metrocluster heal -phase root-aggregates` command.

```

mcc1A::> metrocluster heal -phase root-aggregates
[Job 137] Job succeeded: Heal Root Aggregates is successful

```

If the healing is vetoed, you have the option of reissuing the `metrocluster heal` command with the `-override-vetoes` parameter. If you use this optional parameter, the system overrides any soft vetoes that prevent the healing operation.

7. Verify that the heal operation is complete by using the `metrocluster operation show` command on the destination cluster:

```

mcc1A::> metrocluster operation show
Operation: heal-root-aggregates
State: successful
Start Time: 7/29/2016 20:54:41
End Time: 7/29/2016 20:54:42
Errors: -

```

8. On the impaired controller module, disconnect the power supplies.

## Replace hardware - ASA C400

Move the fans, hard drives, and controller module from the impaired chassis to the new chassis, and swap out the impaired chassis with the new chassis of the same model as the impaired chassis.

### Step 1: Remove the controller modules

To replace the chassis, you must remove the controller modules from the old chassis.

1. If you are not already grounded, properly ground yourself.
2. Release the power cable retainers, and then unplug the cables from the power supplies.
3. Loosen the hook and loop strap binding the cables to the cable management device, and then unplug the system cables and SFPs (if needed) from the controller module, keeping track of where the cables were connected.

Leave the cables in the cable management device so that when you reinstall the cable management device, the cables are organized.

4. Remove and set aside the cable management devices from the left and right sides of the controller module.
5. Press down on both of the locking latches, and then rotate both latches downward at the same time.

The controller module moves slightly out of the chassis.

6. Slide the controller module out of the chassis.

Make sure that you support the bottom of the controller module as you slide it out of the chassis.

7. Set the controller module aside in a safe place, and repeat these steps for the other controller module in the chassis.

## Step 2: Move the fans

To move the fan modules to the replacement chassis when replacing the chassis, you must perform a specific sequence of tasks.

1. If you are not already grounded, properly ground yourself.
2. Remove the bezel (if necessary) with two hands, by grasping the openings on each side of the bezel, and then pulling it toward you until the bezel releases from the ball studs on the chassis frame.
3. Press down the release latch on the fan module cam handle, and then rotate the cam handle downward.

The fan module moves a little bit away from the chassis.

4. Pull the fan module straight out from the chassis, making sure that you support it with your free hand so that it does not swing out of the chassis.



The fan modules are short. Always support the bottom of the fan module with your free hand so that it does not suddenly drop free from the chassis and injure you.

5. Set the fan module aside.
6. Repeat the preceding steps for any remaining fan modules.
7. Insert the fan module into the replacement chassis by aligning it with the opening, and then sliding it into the chassis.
8. Push firmly on the fan module cam handle so that it is seated all the way into the chassis.

The cam handle raises slightly when the fan module is completely seated.

9. Swing the cam handle up to its closed position, making sure that the cam handle release latch clicks into the locked position.
10. Repeat these steps for the remaining fan modules.

## Step 3: Replace a chassis from within the equipment rack or system cabinet

You must remove the existing chassis from the equipment rack or system cabinet before you can install the replacement chassis.

1. Remove the screws from the chassis mount points.

2. With two people, slide the old chassis off the rack rails in a system cabinet or equipment rack, and then set it aside.
3. If you are not already grounded, properly ground yourself.
4. Using two people, install the replacement chassis into the equipment rack or system cabinet by guiding the chassis onto the rack rails in a system cabinet or equipment rack.
5. Slide the chassis all the way into the equipment rack or system cabinet.
6. Secure the front of the chassis to the equipment rack or system cabinet, using the screws you removed from the old chassis.
7. If you have not already done so, install the bezel.

#### Step 4: Install the controller modules

After you install the controller modules into the new chassis, you need to boot it.

For HA pairs with two controller modules in the same chassis, the sequence in which you install the controller module is especially important because it attempts to reboot as soon as you completely seat it in the chassis.

1. Align the end of the controller module with the opening in the chassis, and then gently push the controller module halfway into the system.



Do not completely insert the controller module in the chassis until instructed to do so.

2. Recable the console to the controller module, and then reconnect the management port.
3. Complete the installation of the controller module:
  - a. Plug the power cord into the power supply, reinstall the power cable locking collar, and then connect the power supply to the power source.
  - b. Using the locking latches, firmly push the controller module into the chassis until the locking latches begin to rise.



Do not use excessive force when sliding the controller module into the chassis to avoid damaging the connectors.

- c. Fully seat the controller module in the chassis by rotating the locking latches upward, tilting them so that they clear the locking pins, gently push the controller all the way in, and then lower the locking latches into the locked position.

The controller module begins to boot as soon as it is fully seated in the chassis. Be prepared to interrupt the boot process.

- d. If you have not already done so, reinstall the cable management device.
- e. Interrupt the normal boot process and boot to LOADER by pressing `Ctrl-C`.



If your system stops at the boot menu, select the option to boot to LOADER.

- f. At the LOADER prompt, enter `bye` to reinitialize the PCIe cards and other components.
- g. Interrupt the boot process and boot to the LOADER prompt by pressing `Ctrl-C`.

If your system stops at the boot menu, select the option to boot to LOADER.

4. Repeat the preceding steps to install the second controller into the new chassis.

### Complete the restoration and replacement process - ASA C400

You must verify the HA state of the chassis and return the failed part to NetApp, as described in the RMA instructions shipped with the kit.

#### Step 1: Verify and set the HA state of the chassis

You must verify the HA state of the chassis, and, if necessary, update the state to match your system configuration.

1. In Maintenance mode, from either controller module, display the HA state of the local controller module and chassis: `ha-config show`

The HA state should be the same for all components.

2. If the displayed system state for the chassis does not match your system configuration:

- a. Set the HA state for the chassis: `ha-config modify chassis HA-state`

The value for *HA-state* can be one of the following:

- `ha`
- `mcc`
- `mcc-2n`
- `mccip`
- `non-ha`

- b. Confirm that the setting has changed: `ha-config show`

3. If you have not already done so, recable the rest of your system.
4. Reinstall the bezel on the front of the system.

#### Step 2: Switch back aggregates in a two-node MetroCluster configuration

After you have completed the FRU replacement in a two-node MetroCluster configuration, you can perform the MetroCluster switchback operation. This returns the configuration to its normal operating state, with the sync-source storage virtual machines (SVMs) on the formerly impaired site now active and serving data from the local disk pools.

This task only applies to two-node MetroCluster configurations.

#### Steps

1. Verify that all nodes are in the `enabled state`: `metrocluster node show`



```

cluster_B::> metrocluster node show

DR
Group Cluster Node          Configuration  DR
-----
-----
1      cluster_A
      controller_A_1 configured    enabled    heal roots
completed
      cluster_B
      controller_B_1 configured    enabled    waiting for
switchback recovery
2 entries were displayed.

```

2. Verify that resynchronization is complete on all SVMs: `metrocluster vserver show`
3. Verify that any automatic LIF migrations being performed by the healing operations were completed successfully: `metrocluster check lif show`
4. Perform the switchback by using the `metrocluster switchback` command from any node in the surviving cluster.
5. Verify that the switchback operation has completed: `metrocluster show`

The switchback operation is still running when a cluster is in the `waiting-for-switchback` state:

```

cluster_B::> metrocluster show
Cluster          Configuration State      Mode
-----
Local: cluster_B configured    switchover
Remote: cluster_A configured    waiting-for-switchback

```

The switchback operation is complete when the clusters are in the `normal` state.:

```

cluster_B::> metrocluster show
Cluster          Configuration State      Mode
-----
Local: cluster_B configured    normal
Remote: cluster_A configured    normal

```

If a switchback is taking a long time to finish, you can check on the status of in-progress baselines by using the `metrocluster config-replication resync-status show` command.

6. Reestablish any SnapMirror or SnapVault configurations.

### Step 3: Return the failed part to NetApp

Return the failed part to NetApp, as described in the RMA instructions shipped with the kit. See the [Part Return and Replacements](#) page for further information.

#### Controller

#### Overview of controller module replacement - ASA C400

You must review the prerequisites for the replacement procedure and select the correct one for your version of the ONTAP operating system.

- All drive shelves must be working properly.
- If your system is in a MetroCluster configuration, you must review the section [Choosing the correct recovery procedure](#) to determine whether you should use this procedure.

If this is the procedure you should use, note that the controller replacement procedure for a controller in a four or eight node MetroCluster configuration is the same as that in an HA pair. No MetroCluster-specific steps are required because the failure is restricted to an HA pair and storage failover commands can be used to provide nondisruptive operation during the replacement.

- You must replace the failed component with a replacement FRU component you received from your provider.
- You must be replacing a controller module with a controller module of the same model type. You cannot upgrade your system by just replacing the controller module.
- You cannot change any drives or drive shelves as part of this procedure.
- In this procedure, the boot device is moved from the impaired controller to the *replacement* controller so that the *replacement* controller will boot up in the same version of ONTAP as the old controller module.
- It is important that you apply the commands in these steps on the correct systems:
  - The *impaired* controller is the controller that is being replaced.
  - The *replacement node* is the new controller that is replacing the impaired controller.
  - The *healthy* controller is the surviving controller.
- You must always capture the controller's console output to a text file.

This provides you a record of the procedure so that you can troubleshoot any issues that you might encounter during the replacement process.

#### Shut down the impaired controller - ASA C400

Shut down or take over the impaired controller using the appropriate procedure for your configuration.

## Option 1: Most systems

To shut down the impaired controller, you must determine the status of the controller and, if necessary, take over the controller so that the healthy controller continues to serve data from the impaired controller storage.

### About this task

- If you have a SAN system, you must have checked event messages (`cluster kernel-service show`) for the impaired controller SCSI blade. The `cluster kernel-service show` command (from `priv advanced` mode) displays the node name, quorum status of that node, availability status of that node, and operational status of that node.

Each SCSI-blade process should be in quorum with the other nodes in the cluster. Any issues must be resolved before you proceed with the replacement.

- If you have a cluster with more than two nodes, it must be in quorum. If the cluster is not in quorum or a healthy controller shows false for eligibility and health, you must correct the issue before shutting down the impaired controller; see [Synchronize a node with the cluster](#).

### Steps

1. If AutoSupport is enabled, suppress automatic case creation by invoking an AutoSupport message:

```
system node autosupport invoke -node * -type all -message MAINT=<# of hours>h
```

The following AutoSupport message suppresses automatic case creation for two hours: `cluster1:>`

```
system node autosupport invoke -node * -type all -message MAINT=2h
```

2. Disable automatic giveback from the console of the healthy controller: `storage failover modify -node local -auto-giveback false`



When you see *Do you want to disable auto-giveback?*, enter *y*.

3. Take the impaired controller to the LOADER prompt:

If the impaired controller is displaying...	Then...
The LOADER prompt	Go to the next step.
Waiting for giveback...	Press Ctrl-C, and then respond <i>y</i> when prompted.
System prompt or password prompt	Take over or halt the impaired controller from the healthy controller: <code>storage failover takeover -ofnode <i>impaired_node_name</i></code>  When the impaired controller shows Waiting for giveback..., press Ctrl-C, and then respond <i>y</i> .

## Option 2: Controller is in a two-node MetroCluster

To shut down the impaired controller, you must determine the status of the controller and, if necessary,

switch over the controller so that the healthy controller continues to serve data from the impaired controller storage.

### About this task

- You must leave the power supplies turned on at the end of this procedure to provide power to the healthy controller.

### Steps

1. Check the MetroCluster status to determine whether the impaired controller has automatically switched over to the healthy controller: `metrocluster show`
2. Depending on whether an automatic switchover has occurred, proceed according to the following table:

If the impaired controller...	Then...
Has automatically switched over	Proceed to the next step.
Has not automatically switched over	Perform a planned switchover operation from the healthy controller: <code>metrocluster switchover</code>
Has not automatically switched over, you attempted switchover with the <code>metrocluster switchover</code> command, and the switchover was vetoed	Review the veto messages and, if possible, resolve the issue and try again. If you are unable to resolve the issue, contact technical support.

3. Resynchronize the data aggregates by running the `metrocluster heal -phase aggregates` command from the surviving cluster.

```
controller_A_1::> metrocluster heal -phase aggregates
[Job 130] Job succeeded: Heal Aggregates is successful.
```

If the healing is vetoed, you have the option of reissuing the `metrocluster heal` command with the `-override-vetoes` parameter. If you use this optional parameter, the system overrides any soft vetoes that prevent the healing operation.

4. Verify that the operation has been completed by using the `metrocluster operation show` command.

```
controller_A_1::> metrocluster operation show
  Operation: heal-aggregates
  State: successful
Start Time: 7/25/2016 18:45:55
End Time: 7/25/2016 18:45:56
Errors: -
```

5. Check the state of the aggregates by using the `storage aggregate show` command.

```

controller_A_1::> storage aggregate show
Aggregate      Size Available Used% State   #Vols  Nodes
RAID Status
-----
...
aggr_b2       227.1GB   227.1GB   0% online    0 mcc1-a2
raid_dp, mirrored, normal...

```

6. Heal the root aggregates by using the `metrocluster heal -phase root-aggregates` command.

```

mcc1A::> metrocluster heal -phase root-aggregates
[Job 137] Job succeeded: Heal Root Aggregates is successful

```

If the healing is vetoed, you have the option of reissuing the `metrocluster heal` command with the `-override-vetoes` parameter. If you use this optional parameter, the system overrides any soft vetoes that prevent the healing operation.

7. Verify that the heal operation is complete by using the `metrocluster operation show` command on the destination cluster:

```

mcc1A::> metrocluster operation show
Operation: heal-root-aggregates
State: successful
Start Time: 7/29/2016 20:54:41
End Time: 7/29/2016 20:54:42
Errors: -

```

8. On the impaired controller module, disconnect the power supplies.

## Replace the controller module hardware - ASA C400

To replace the controller module hardware, you must remove the impaired controller, move FRU components to the replacement controller module, install the replacement controller module in the chassis, and then boot the system to Maintenance mode.

### Step 1: Remove the controller module

To access components inside the controller module, you must remove the controller module from the chassis.

1. If you are not already grounded, properly ground yourself.
2. Release the power cable retainers, and then unplug the cables from the power supplies.
3. Loosen the hook and loop strap binding the cables to the cable management device, and then unplug the

system cables and SFPs (if needed) from the controller module, keeping track of where the cables were connected.

Leave the cables in the cable management device so that when you reinstall the cable management device, the cables are organized.

4. Remove the cable management device from the controller module and set it aside.
5. Press down on both of the locking latches, and then rotate both latches downward at the same time.

The controller module moves slightly out of the chassis.

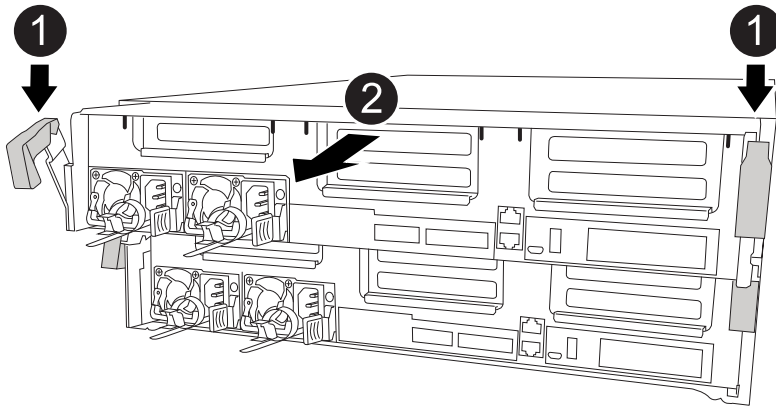

<b>1</b>	Locking latches
<b>2</b>	Controller moves slightly out of chassis

6. Slide the controller module out of the chassis.

Make sure that you support the bottom of the controller module as you slide it out of the chassis.

7. Place the controller module on a stable, flat surface.
8. On the replacement controller module, open the air duct and remove the empty risers from the controller module using the animation, illustration, or the written steps:

[Animation - Remove the empty risers from the replacement controller module](#)

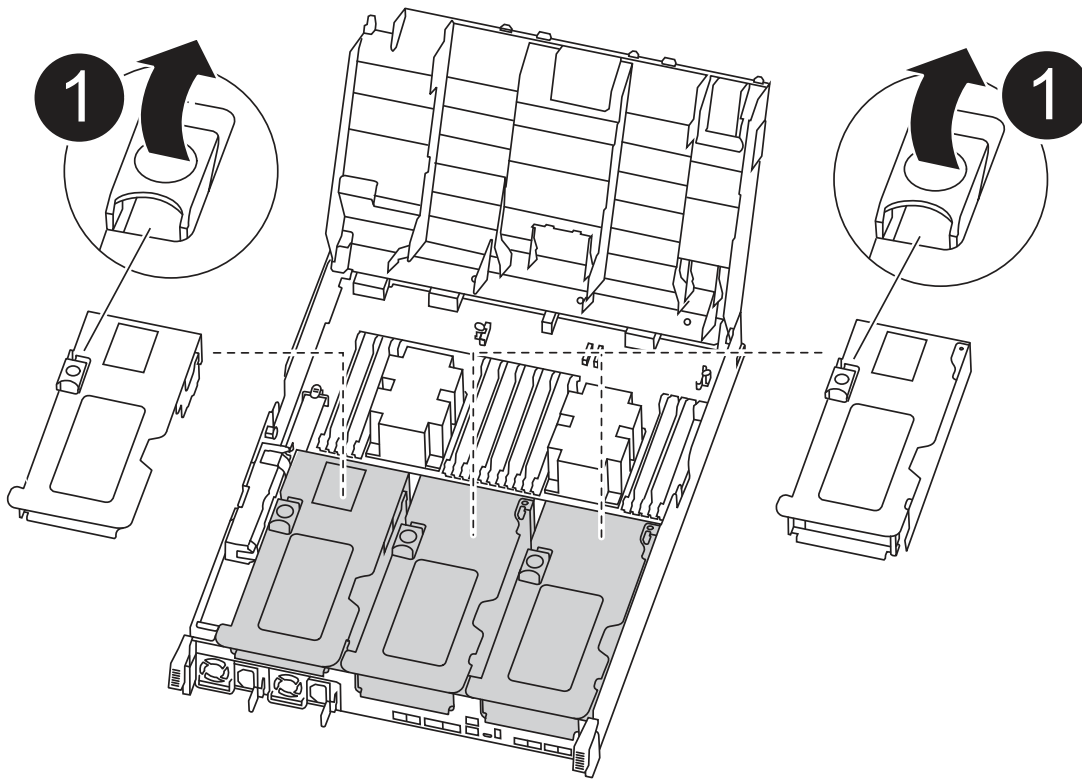

1

Riser latches

- a. Press the locking tabs on the sides of the air duct in toward the middle of the controller module.
- b. Slide the air duct toward the back of the controller module, and then rotate it upward to its completely open position.
- c. Rotate the riser locking latch on the left side of riser 1 up and toward air duct, lift the riser up, and then set it aside.
- d. Repeat the previous step for the remaining risers.

### Step 2: Move the power supplies

You must move the power supply from the impaired controller module to the replacement controller module when you replace a controller module.

You can use the following animation, illustration, or the written steps to move the power supplies to the replacement controller module.

[Animation - Move the power supplies](#)

1. Remove the power supply:

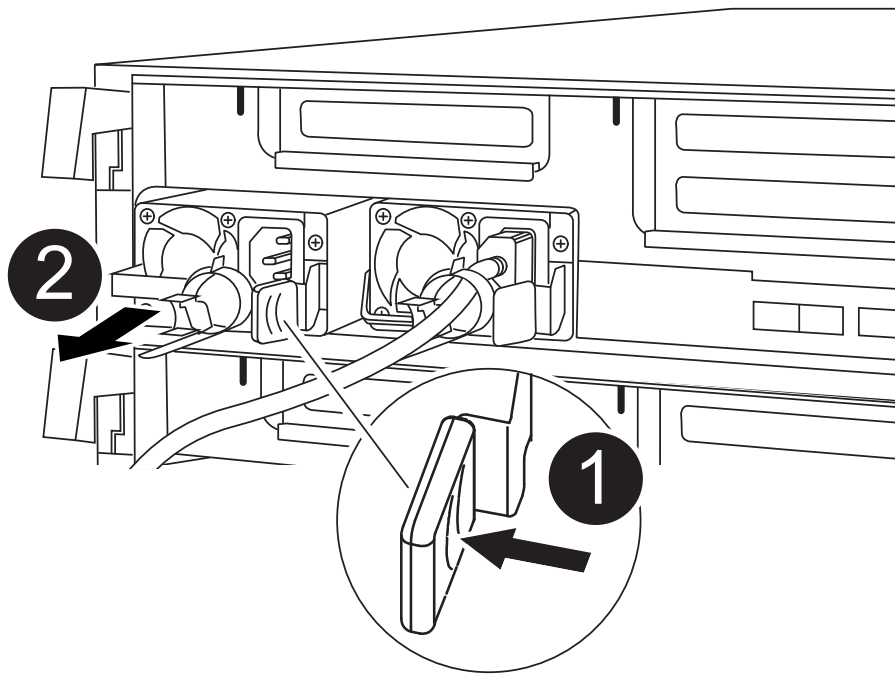

1	PSU locking tab
2	Power cable retainer

- a. Rotate the cam handle so that it can be used to pull the power supply out of the chassis.
- b. Press the blue locking tab to release the power supply from the chassis.
- c. Using both hands, pull the power supply out of the chassis, and then set it aside.
  1. Move the power supply to the new controller module, and then install it.
  2. Using both hands, support and align the edges of the power supply with the opening in the controller module, and then gently push the power supply into the controller module until the locking tab clicks into place.

The power supplies will only properly engage with the internal connector and lock in place one way.



To avoid damaging the internal connector, do not use excessive force when sliding the power supply into the system.

3. Repeat the preceding steps for any remaining power supplies.

### Step 3: Move the NVDIMM battery

To move the NVDIMM battery from the impaired controller module to the replacement controller module, you must perform a specific sequence of steps.

You can use the following animation, illustration, or the written steps to move the NVDIMM battery from the impaired controller module to the replacement controller module.



## Animation - Move the NVDIMM battery

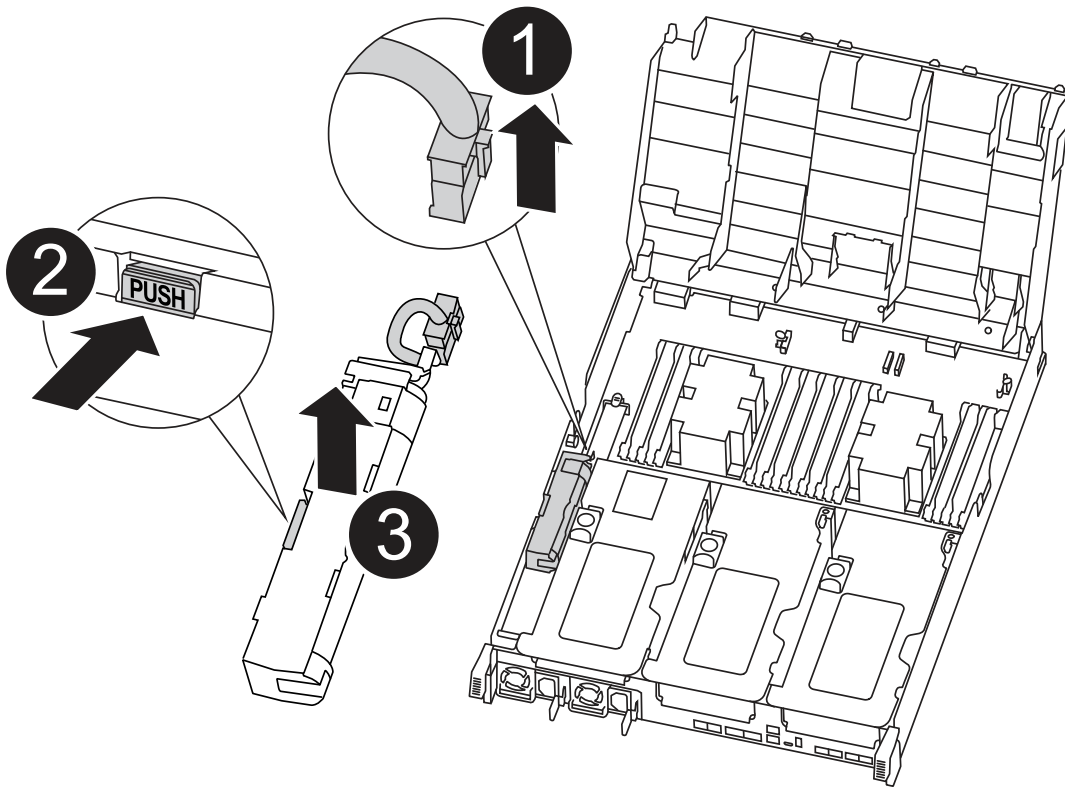

1	NVDIMM battery plug
2	NVDIMM battery locking tab
3	NVDIMM battery

1. Open the air duct:
  - a. Press the locking tabs on the sides of the air duct in toward the middle of the controller module.
  - b. Slide the air duct toward the back of the controller module, and then rotate it upward to its completely open position.
2. Locate the NVDIMM battery in the controller module.
3. Locate the battery plug and squeeze the clip on the face of the battery plug to release the plug from the socket, and then unplug the battery cable from the socket.
4. Grasp the battery and press the blue locking tab marked PUSH, and then lift the battery out of the holder and controller module.
5. Move the battery to the replacement controller module.
6. Align the battery module with the opening for the battery, and then gently push the battery into slot until it locks into place.



Do not plug the battery cable back into the motherboard until instructed to do so.

#### Step 4: Move the boot media

You must locate the boot media, and then follow the directions to remove it from the impaired controller module and insert it into the replacement controller module.

You can use the following animation, illustration, or the written steps to move the boot media from the impaired controller module to the replacement controller module.

#### Animation - Move the boot media

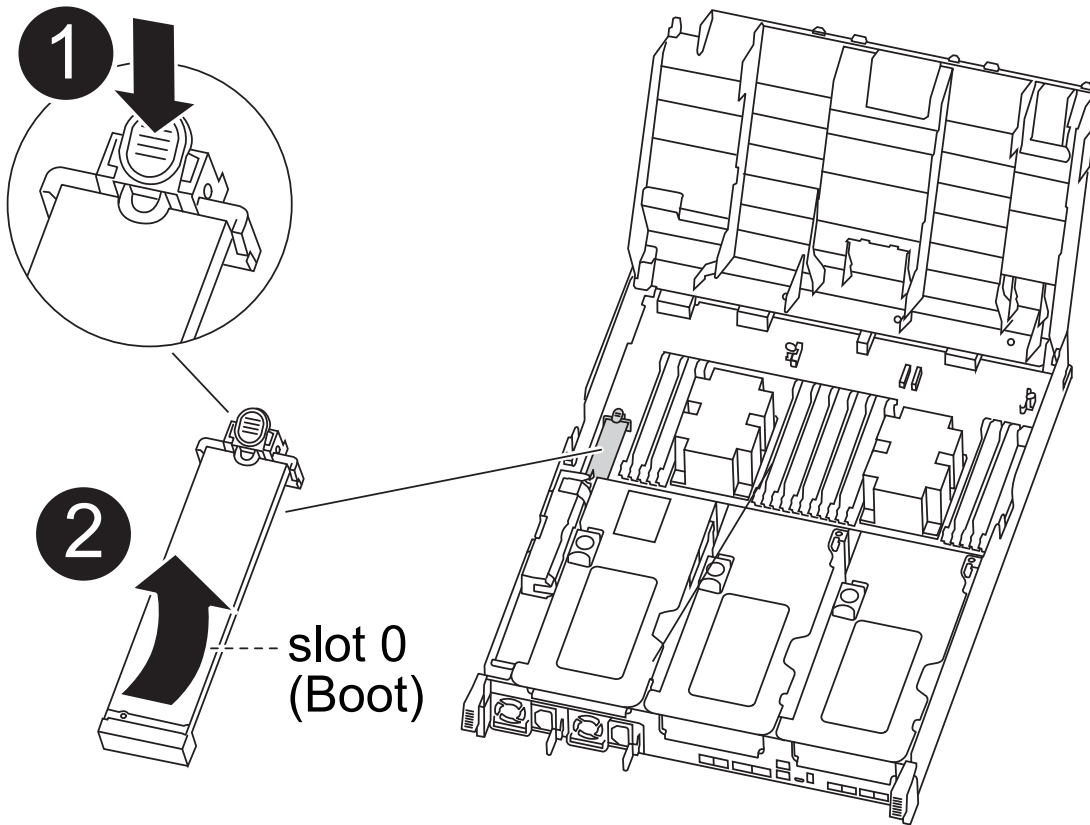

1	Boot media locking tab
2	Boot media

1. Locate and remove the boot media from the controller module:
  - a. Press the blue button at the end of the boot media until the lip on the boot media clears the blue button.
  - b. Rotate the boot media up and gently pull the boot media out of the socket.
2. Move the boot media to the new controller module, align the edges of the boot media with the socket housing, and then gently push it into the socket.
3. Check the boot media to make sure that it is seated squarely and completely in the socket.

If necessary, remove the boot media and reseal it into the socket.

4. Lock the boot media in place:

- a. Rotate the boot media down toward the motherboard.
- b. Press the blue locking button so that it is in the open position.
- c. Placing your fingers at the end of the boot media by the blue button, firmly push down on the boot media end to engage the blue locking button.

### Step 5: Move the PCIe risers and mezzanine card

As part of the controller replacement process, you must move the PCIe risers and mezzanine card from the impaired controller module to the replacement controller module.

You can use the following animations, illustrations, or the written steps to move the PCIe risers and mezzanine card from the impaired controller module to the replacement controller module.

Moving PCIe riser 1 and 2 (left and middle risers):

[Animation - Move PCI risers 1 and 2](#)

Moving the mezzanine card and riser 3 (right riser):

[Animation - Move the mezzanine card and riser 3](#)

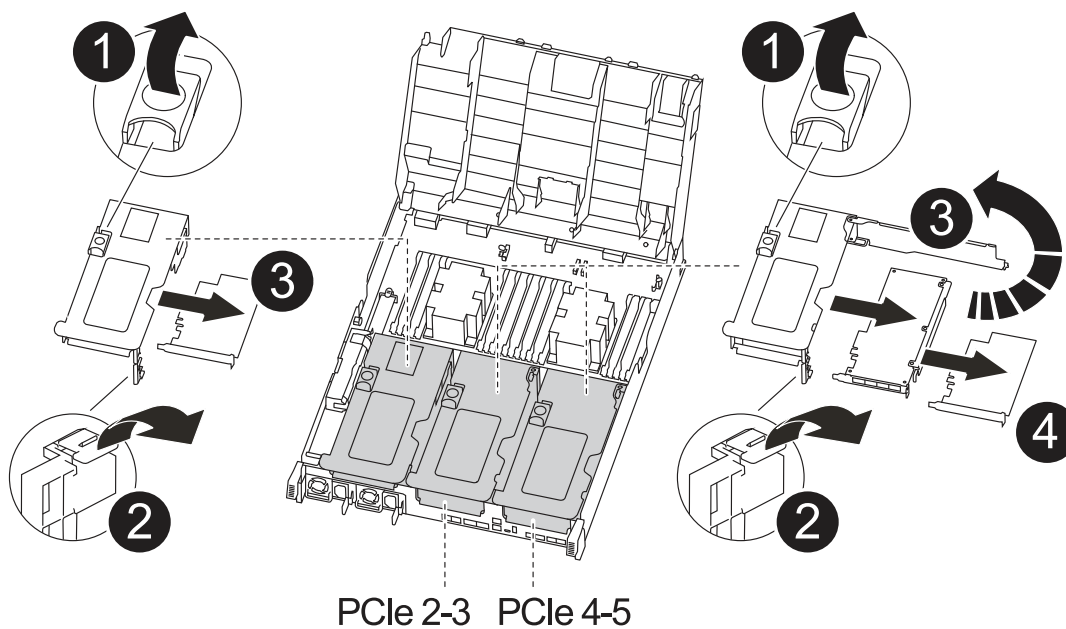

1	Riser locking latch
2	PCI card locking latch
3	PCI locking plate
4	PCI card

1. Move PCIe risers one and two from the impaired controller module to the replacement controller module:
  - a. Remove any SFP or QSFP modules that might be in the PCIe cards.
  - b. Rotate the riser locking latch on the left side of the riser up and toward air duct.

The riser raises up slightly from the controller module.

- c. Lift the riser up, and then move it to the replacement controller module.
  - d. Align the riser with the pins to the side of the riser socket, lower the riser down on the pins, push the riser squarely into the socket on the motherboard, and then rotate the latch down flush with the sheet metal on the riser.
  - e. Repeat this step for riser number 2.
2. Remove riser number 3, remove the mezzanine card, and install both into the replacement controller module:
  - a. Remove any SFP or QSFP modules that might be in the PCIe cards.
  - b. Rotate the riser locking latch on the left side of the riser up and toward air duct.

The riser raises up slightly from the controller module.

- c. Lift the riser up, and then set it aside on a stable, flat surface.
  - d. Loosen the thumbscrews on the mezzanine card, and gently lift the card directly out of the socket, and then move it to the replacement controller module.
  - e. Install the mezzanine in the replacement controller and secure it with the thumbscrews.
  - f. Install the third riser in the replacement controller module.

## **Step 6: Move the DIMMs**

You need to locate the DIMMs, and then move them from the impaired controller module to the replacement controller module.

You must have the new controller module ready so that you can move the DIMMs directly from the impaired controller module to the corresponding slots in the replacement controller module.

You can use the following animation, illustration, or the written steps to move the DIMMs from the impaired controller module to the replacement controller module.

[Animation - Move the DIMMs](#)

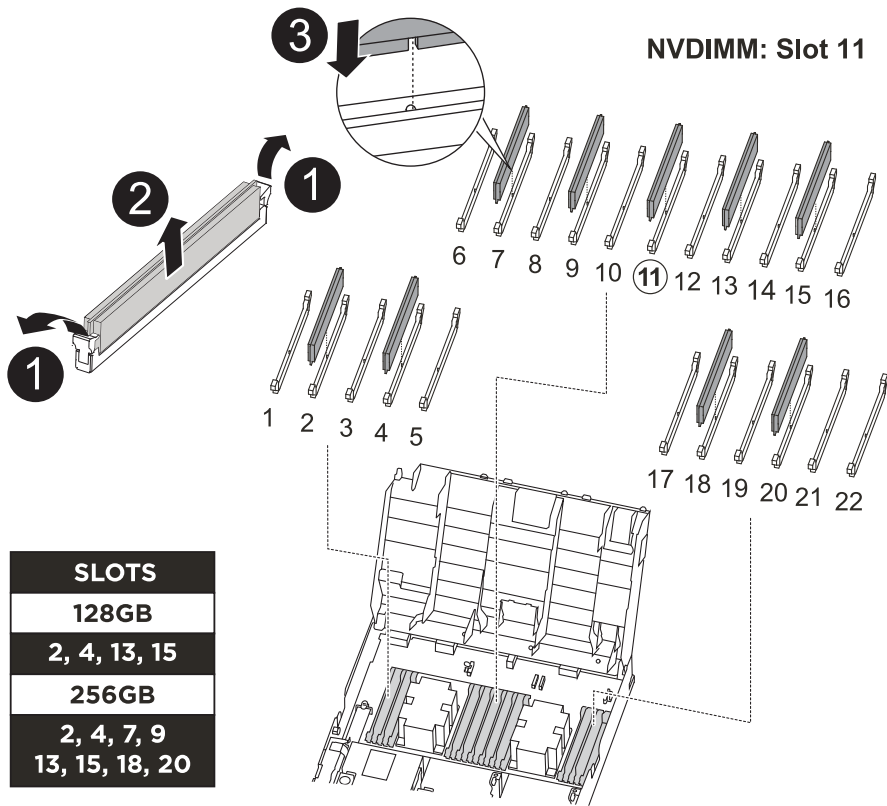

<b>1</b>	DIMM locking tabs
<b>2</b>	DIMM
<b>3</b>	DIMM socket

1. Locate the DIMMs on your controller module.
2. Note the orientation of the DIMM in the socket so that you can insert the DIMM in the replacement controller module in the proper orientation.
3. Verify that the NVDIMM battery is not plugged into the new controller module.
4. Move the DIMMs from the impaired controller module to the replacement controller module:



Make sure that you install the each DIMM into the same slot it occupied in the impaired controller module.

- a. Eject the DIMM from its slot by slowly pushing apart the DIMM ejector tabs on either side of the DIMM, and then slide the DIMM out of the slot.



Carefully hold the DIMM by the edges to avoid pressure on the components on the DIMM circuit board.

- b. Locate the corresponding DIMM slot on the replacement controller module.
- c. Make sure that the DIMM ejector tabs on the DIMM socket are in the open position, and then insert the

DIMM squarely into the socket.

The DIMMs fit tightly in the socket, but should go in easily. If not, realign the DIMM with the socket and reinsert it.

- d. Visually inspect the DIMM to verify that it is evenly aligned and fully inserted into the socket.
  - e. Repeat these substeps for the remaining DIMMs.
5. Plug the NVDIMM battery into the motherboard.

Make sure that the plug locks down onto the controller module.

### Step 7: Install the controller module

After all of the components have been moved from the impaired controller module to the replacement controller module, you must install the replacement controller module into the chassis, and then boot it to Maintenance mode.

1. If you have not already done so, close the air duct.
2. Align the end of the controller module with the opening in the chassis, and then gently push the controller module halfway into the system.



Do not completely insert the controller module in the chassis until instructed to do so.

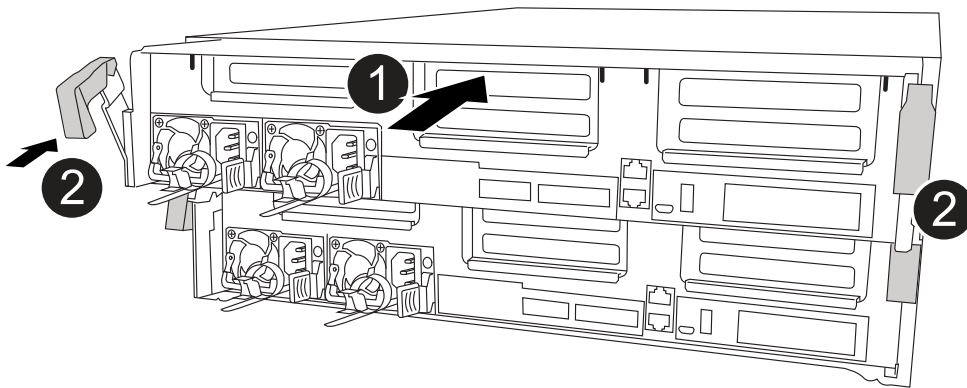

<b>1</b>	Slide controller into the chassis
<b>2</b>	Locking latches

3. Cable the management and console ports only, so that you can access the system to perform the tasks in the following sections.



You will connect the rest of the cables to the controller module later in this procedure.

4. Complete the installation of the controller module:

- a. Plug the power cord into the power supply, reinstall the power cable locking collar, and then connect the power supply to the power source.
- b. Using the locking latches, firmly push the controller module into the chassis until the locking latches begin to rise.



Do not use excessive force when sliding the controller module into the chassis to avoid damaging the connectors.

- c. Fully seat the controller module in the chassis by rotating the locking latches upward, tilting them so that they clear the locking pins, gently push the controller all the way in, and then lower the locking latches into the locked position.

The controller module begins to boot as soon as it is fully seated in the chassis. Be prepared to interrupt the boot process.

- d. If you have not already done so, reinstall the cable management device.
- e. Interrupt the normal boot process and boot to LOADER by pressing `Ctrl-C`.



If your system stops at the boot menu, select the option to boot to LOADER.

- f. At the LOADER prompt, enter `bye` to reinitialize the PCIe cards and other components.
- g. Interrupt the boot process and boot to the LOADER prompt by pressing `Ctrl-C`.

If your system stops at the boot menu, select the option to boot to LOADER.

## Restore and verify the system configuration - ASA C400

After completing the hardware replacement and booting to Maintenance mode, you verify the low-level system configuration of the replacement controller and reconfigure system settings as necessary.

### Step 1: Set and verify system time after replacing the controller

You should check the time and date on the replacement controller module against the healthy controller module in an HA pair, or against a reliable time server in a stand-alone configuration. If the time and date do not match, you must reset them on the replacement controller module to prevent possible outages on clients due to time differences.

#### About this task

It is important that you apply the commands in the steps on the correct systems:

- The *replacement* node is the new node that replaced the impaired node as part of this procedure.
- The *healthy* node is the HA partner of the *replacement* node.

#### Steps

1. If the *replacement* node is not at the LOADER prompt, halt the system to the LOADER prompt.
2. On the *healthy* node, check the system time: `cluster date show`

The date and time are based on the configured timezone.

3. At the LOADER prompt, check the date and time on the *replacement* node: `show date`

The date and time are given in GMT.

4. If necessary, set the date in GMT on the replacement node: `set date mm/dd/yyyy`
5. If necessary, set the time in GMT on the replacement node: `set time hh:mm:ss`
6. At the LOADER prompt, confirm the date and time on the *replacement* node: `show date`

The date and time are given in GMT.

## Step 2: Verify and set the HA state of the controller module

You must verify the HA state of the controller module and, if necessary, update the state to match your system configuration.

1. In Maintenance mode from the new controller module, verify that all components display the same HA state: `ha-config show`

The HA state should be the same for all components.

2. If the displayed system state of the controller module does not match your system configuration, set the HA state for the controller module: `ha-config modify controller ha-state`

The value for HA-state can be one of the following:

- `ha`
- `mcc`
- `mcc-2n`
- `mccip`
- `non-ha`

3. If the displayed system state of the controller module does not match your system configuration, set the HA state for the controller module: `ha-config modify controller ha-state`
4. Confirm that the setting has changed: `ha-config show`

## Recable the system and reassign disks - ASA C400

Continue the replacement procedure by recabling the storage and confirming disk reassignment.

### Step 1: Recable the system

Recable the controller module's storage and network connections.

#### Steps

1. Recable the the controller module to storage and network connections.
2. Verify that the cabling is correct by using [Active IQ Config Advisor](#).
  - a. Download and install Config Advisor.



- b. Enter the information for the target system, and then click Collect Data.
- c. Click the Cabling tab, and then examine the output. Make sure that all disk shelves are displayed and all disks appear in the output, correcting any cabling issues you find.
- d. Check other cabling by clicking the appropriate tab, and then examining the output from Config Advisor.

## Step 2: Reassign disks

If the storage system is in an HA pair, the system ID of the new controller module is automatically assigned to the disks when the giveback occurs at the end of the procedure. You must confirm the system ID change when you boot the *replacement* controller and then verify that the change was implemented.

This procedure applies only to systems running ONTAP in an HA pair.

1. If the *replacement* controller is in Maintenance mode (showing the `*>` prompt, exit Maintenance mode and go to the LOADER prompt: `halt`
2. From the LOADER prompt on the *replacement* controller, boot the controller, entering `y` if you are prompted to override the system ID due to a system ID mismatch: `boot_ontap`
3. Wait until the `Waiting for giveback...` message is displayed on the *replacement* controller console and then, from the healthy controller, verify that the new partner system ID has been automatically assigned: `storage failover show`

In the command output, you should see a message that the system ID has changed on the impaired controller, showing the correct old and new IDs. In the following example, node2 has undergone replacement and has a new system ID of 151759706.

```
node1> `storage failover show`
```

Node	Partner	Takeover Possible	State Description
node1	node2	false	System ID changed on partner (Old: 151759706), In takeover
node2	node1	-	Waiting for giveback (HA mailboxes)

4. From the healthy controller, verify that any coredumps are saved:
  - a. Change to the advanced privilege level: `set -privilege advanced`

You can respond `y` when prompted to continue into advanced mode. The advanced mode prompt appears (`*>`).

- b. Save any coredumps: `system node run -node local-node-name partner savecore`
- c. Wait for the `savecore` command to complete before issuing the giveback.

You can enter the following command to monitor the progress of the `savecore` command: `system`

```
node run -node local-node-name partner savecore -s
```

d. Return to the admin privilege level: `set -privilege admin`

5. If your storage system has Storage or Volume Encryption configured, you must restore Storage or Volume Encryption functionality by using one of the following procedures, depending on whether you are using onboard or external key management:

- [Restore onboard key management encryption keys](#)
- [Restore external key management encryption keys](#)

6. Give back the controller:

a. From the healthy controller, give back the replaced controller's storage: `storage failover giveback -ofnode replacement_node_name`

The *replacement* controller takes back its storage and completes booting.

If you are prompted to override the system ID due to a system ID mismatch, you should enter `y`.



If the giveback is vetoed, you can consider overriding the vetoes.

[Find the High-Availability Configuration content for your version of ONTAP 9](#)

b. After the giveback has been completed, confirm that the HA pair is healthy and that takeover is possible: `storage failover show`

The output from the `storage failover show` command should not include the System ID changed on partner message.

7. Verify that the disks were assigned correctly: `storage disk show -ownership`

The disks belonging to the *replacement* controller should show the new system ID. In the following example, the disks owned by node1 now show the new system ID, 1873775277:

```
node1> `storage disk show -ownership`

Disk Aggregate Home Owner DR Home Home ID Owner ID DR Home ID
Reserver Pool
-----
-----
-----
1.0.0 aggr0_1 node1 node1 - 1873775277 1873775277 -
1873775277 Pool0
1.0.1 aggr0_1 node1 node1 1873775277 1873775277 -
1873775277 Pool0
.
.
.
```

8. If the system is in a MetroCluster configuration, monitor the status of the controller: `metrocluster node show`

The MetroCluster configuration takes a few minutes after the replacement to return to a normal state, at which time each controller will show a configured state, with DR Mirroring enabled and a mode of normal. The `metrocluster node show -fields node-systemid` command output displays the old system ID until the MetroCluster configuration returns to a normal state.

- If the controller is in a MetroCluster configuration, depending on the MetroCluster state, verify that the DR home ID field shows the original owner of the disk if the original owner is a controller on the disaster site.

This is required if both of the following are true:

- The MetroCluster configuration is in a switchover state.
- The *replacement* controller is the current owner of the disks on the disaster site.

[Disk ownership changes during HA takeover and MetroCluster switchover in a four-node MetroCluster configuration](#)

- If your system is in a MetroCluster configuration, verify that each controller is configured: `metrocluster node show -fields configuration-state`

```
node1_siteA::> metrocluster node show -fields configuration-state

dr-group-id          cluster node          configuration-state
-----
-----
1 node1_siteA        node1mcc-001         configured
1 node1_siteA        node1mcc-002         configured
1 node1_siteB        node1mcc-003         configured
1 node1_siteB        node1mcc-004         configured

4 entries were displayed.
```

- Verify that the expected volumes are present for each controller: `vol show -node node-name`
- If you disabled automatic takeover on reboot, enable it from the healthy controller: `storage failover modify -node replacement-node-name -onreboot true`

### Complete system restoration - ASA C400

To restore your system to full operation, you must restore the NetApp Storage Encryption configuration (if necessary), and install licenses for the new controller, and return the failed part to NetApp, as described in the RMA instructions shipped with the kit.

#### Step 1: Install licenses for the replacement controller in ONTAP

You must install new licenses for the *replacement* node if the impaired node was using ONTAP features that require a standard (node-locked) license. For features with standard licenses, each node in the cluster should have its own key for the feature.

#### About this task

Until you install license keys, features requiring standard licenses continue to be available to the *replacement*

node. However, if the impaired node was the only node in the cluster with a license for the feature, no configuration changes to the feature are allowed. Also, using unlicensed features on the node might put you out of compliance with your license agreement, so you should install the replacement license key or keys on the *replacement* node as soon as possible.

### Before you begin

The licenses keys must be in the 28-character format.

You have a 90-day grace period in which to install the license keys. After the grace period, all old licenses are invalidated. After a valid license key is installed, you have 24 hours to install all of the keys before the grace period ends.

### Steps

1. If you need new license keys, obtain replacement license keys on the [NetApp Support Site](#) in the My Support section under Software licenses.



The new license keys that you require are automatically generated and sent to the email address on file. If you fail to receive the email with the license keys within 30 days, you should contact technical support.

2. Install each license key: `system license add -license-code license-key, license-key...`
3. Remove the old licenses, if desired:
  - a. Check for unused licenses: `license clean-up -unused -simulate`
  - b. If the list looks correct, remove the unused licenses: `license clean-up -unused`

### Step 2: Verify LIFs and registering the serial number

Before returning the *replacement* node to service, you should verify that the LIFs are on their home ports, and register the serial number of the *replacement* node if AutoSupport is enabled, and reset automatic giveback.

### Steps

1. Verify that the logical interfaces are reporting to their home server and ports: `network interface show -is-home false`  
  
If any LIFs are listed as false, revert them to their home ports: `network interface revert -vserver * -lif *`
2. Register the system serial number with NetApp Support.
  - If AutoSupport is enabled, send an AutoSupport message to register the serial number.
  - If AutoSupport is not enabled, call [NetApp Support](#) to register the serial number.
3. If an AutoSupport maintenance window was triggered, end it by using the `system node autosupport invoke -node * -type all -message MAINT=END` command.
4. If automatic giveback was disabled, reenable it: `storage failover modify -node local -auto-giveback true`

### Step 3: Switch back aggregates in a two-node MetroCluster configuration

After you have completed the FRU replacement in a two-node MetroCluster configuration, you can perform the MetroCluster switchback operation. This returns the configuration to its normal operating state, with the sync-

source storage virtual machines (SVMs) on the formerly impaired site now active and serving data from the local disk pools.

This task only applies to two-node MetroCluster configurations.

### Steps

1. Verify that all nodes are in the enabled state: `metrocluster node show`

```
cluster_B::> metrocluster node show

DR                               Configuration  DR
Group Cluster Node              State          Mirroring Mode
-----
1      cluster_A
      controller_A_1 configured      enabled      heal roots
completed
      cluster_B
      controller_B_1 configured      enabled      waiting for
switchback recovery
2 entries were displayed.
```

2. Verify that resynchronization is complete on all SVMs: `metrocluster vserver show`
3. Verify that any automatic LIF migrations being performed by the healing operations were completed successfully: `metrocluster check lif show`
4. Perform the switchback by using the `metrocluster switchback` command from any node in the surviving cluster.
5. Verify that the switchback operation has completed: `metrocluster show`

The switchback operation is still running when a cluster is in the `waiting-for-switchback` state:

```
cluster_B::> metrocluster show
Cluster              Configuration State      Mode
-----
Local: cluster_B configured      switchover
Remote: cluster_A configured      waiting-for-switchback
```

The switchback operation is complete when the clusters are in the `normal` state.:

```

cluster_B::> metrocluster show
Cluster           Configuration State      Mode
-----
Local: cluster_B configured      normal
Remote: cluster_A configured      normal

```

If a switchback is taking a long time to finish, you can check on the status of in-progress baselines by using the `metrocluster config-replication resync-status show` command.

6. Reestablish any SnapMirror or SnapVault configurations.

#### Step 4: Return the failed part to NetApp

Return the failed part to NetApp, as described in the RMA instructions shipped with the kit. See the [Part Return and Replacements](#) page for further information.

#### Replace a DIMM - ASA C400

You must replace a DIMM in the controller module when your system registers an increasing number of correctable error correction codes (ECC); failure to do so causes a system panic.

All other components in the system must be functioning properly; if not, you must contact technical support.

You must replace the failed component with a replacement FRU component you received from your provider.

#### Step 1: Shut down the impaired controller

Shut down or take over the impaired controller using the appropriate procedure for your configuration.

## Option 1: Most configurations

To shut down the impaired controller, you must determine the status of the controller and, if necessary, take over the controller so that the healthy controller continues to serve data from the impaired controller storage.

### About this task

- If you have a SAN system, you must have checked event messages (`cluster kernel-service show`) for the impaired controller SCSI blade. The `cluster kernel-service show` command (from `priv advanced` mode) displays the node name, quorum status of that node, availability status of that node, and operational status of that node.

Each SCSI-blade process should be in quorum with the other nodes in the cluster. Any issues must be resolved before you proceed with the replacement.

- If you have a cluster with more than two nodes, it must be in quorum. If the cluster is not in quorum or a healthy controller shows false for eligibility and health, you must correct the issue before shutting down the impaired controller; see [Synchronize a node with the cluster](#).

### Steps

1. If AutoSupport is enabled, suppress automatic case creation by invoking an AutoSupport message:  

```
system node autosupport invoke -node * -type all -message MAINT=<# of hours>h
```

The following AutoSupport message suppresses automatic case creation for two hours: `cluster1:>`  

```
system node autosupport invoke -node * -type all -message MAINT=2h
```

2. Disable automatic giveback from the console of the healthy controller: 

```
storage failover modify -node local -auto-giveback false
```



When you see *Do you want to disable auto-giveback?*, enter *y*.

3. Take the impaired controller to the LOADER prompt:

If the impaired controller is displaying...	Then...
The LOADER prompt	Go to the next step.
Waiting for giveback...	Press Ctrl-C, and then respond <i>y</i> when prompted.
System prompt or password prompt	Take over or halt the impaired controller from the healthy controller: <pre>storage failover takeover -ofnode impaired_node_name</pre> When the impaired controller shows Waiting for giveback..., press Ctrl-C, and then respond <i>y</i> .

## Option 2: Controller is in a two-node MetroCluster

To shut down the impaired controller, you must determine the status of the controller and, if necessary,

switch over the controller so that the healthy controller continues to serve data from the impaired controller storage.

### About this task

- You must leave the power supplies turned on at the end of this procedure to provide power to the healthy controller.

### Steps

1. Check the MetroCluster status to determine whether the impaired controller has automatically switched over to the healthy controller: `metrocluster show`
2. Depending on whether an automatic switchover has occurred, proceed according to the following table:

If the impaired controller...	Then...
Has automatically switched over	Proceed to the next step.
Has not automatically switched over	Perform a planned switchover operation from the healthy controller: <code>metrocluster switchover</code>
Has not automatically switched over, you attempted switchover with the <code>metrocluster switchover</code> command, and the switchover was vetoed	Review the veto messages and, if possible, resolve the issue and try again. If you are unable to resolve the issue, contact technical support.

3. Resynchronize the data aggregates by running the `metrocluster heal -phase aggregates` command from the surviving cluster.

```
controller_A_1::> metrocluster heal -phase aggregates
[Job 130] Job succeeded: Heal Aggregates is successful.
```

If the healing is vetoed, you have the option of reissuing the `metrocluster heal` command with the `-override-vetoes` parameter. If you use this optional parameter, the system overrides any soft vetoes that prevent the healing operation.

4. Verify that the operation has been completed by using the `metrocluster operation show` command.

```
controller_A_1::> metrocluster operation show
  Operation: heal-aggregates
  State: successful
Start Time: 7/25/2016 18:45:55
End Time: 7/25/2016 18:45:56
Errors: -
```

5. Check the state of the aggregates by using the `storage aggregate show` command.



```

controller_A_1::> storage aggregate show
Aggregate      Size Available Used% State   #Vols  Nodes
RAID Status
-----
...
aggr_b2       227.1GB   227.1GB   0% online    0 mcc1-a2
raid_dp, mirrored, normal...

```

6. Heal the root aggregates by using the `metrocluster heal -phase root-aggregates` command.

```

mcc1A::> metrocluster heal -phase root-aggregates
[Job 137] Job succeeded: Heal Root Aggregates is successful

```

If the healing is vetoed, you have the option of reissuing the `metrocluster heal` command with the `-override-vetoes` parameter. If you use this optional parameter, the system overrides any soft vetoes that prevent the healing operation.

7. Verify that the heal operation is complete by using the `metrocluster operation show` command on the destination cluster:

```

mcc1A::> metrocluster operation show
Operation: heal-root-aggregates
State: successful
Start Time: 7/29/2016 20:54:41
End Time: 7/29/2016 20:54:42
Errors: -

```

8. On the impaired controller module, disconnect the power supplies.

## Step 2: Remove the controller module

To access components inside the controller module, you must remove the controller module from the chassis.

1. If you are not already grounded, properly ground yourself.
2. Release the power cable retainers, and then unplug the cables from the power supplies.
3. Loosen the hook and loop strap binding the cables to the cable management device, and then unplug the system cables and SFPs (if needed) from the controller module, keeping track of where the cables were connected.

Leave the cables in the cable management device so that when you reinstall the cable management device, the cables are organized.

4. Remove the cable management device from the controller module and set it aside.

5. Press down on both of the locking latches, and then rotate both latches downward at the same time.

The controller module moves slightly out of the chassis.

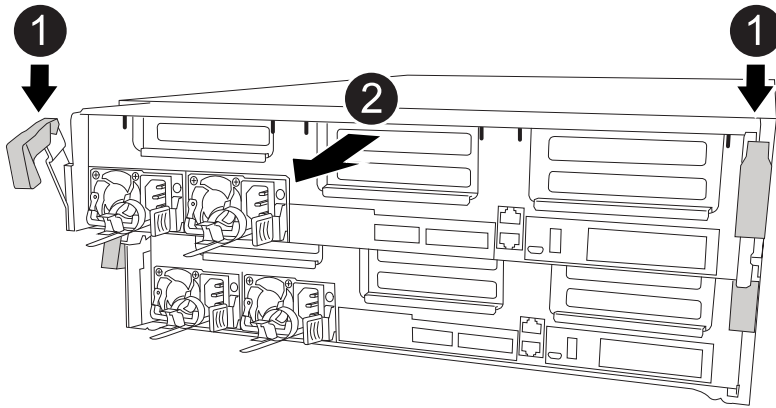

<b>1</b>	Locking latches
<b>2</b>	Controller moves slightly out of chassis

6. Slide the controller module out of the chassis.

Make sure that you support the bottom of the controller module as you slide it out of the chassis.

7. Place the controller module on a stable, flat surface.

### Step 3: Replace system DIMMs

Replacing a system DIMM involves identifying the target DIMM through the associated error message, locating the target DIMM using the FRU map on the air duct, and then replacing the DIMM.

You can use the following animation, illustration, or the written steps to replace a system DIMM.



The animation and illustration show empty slots for sockets without DIMMs. These empty sockets are populated with blanks.

[Animation - Replace a system DIMM](#)

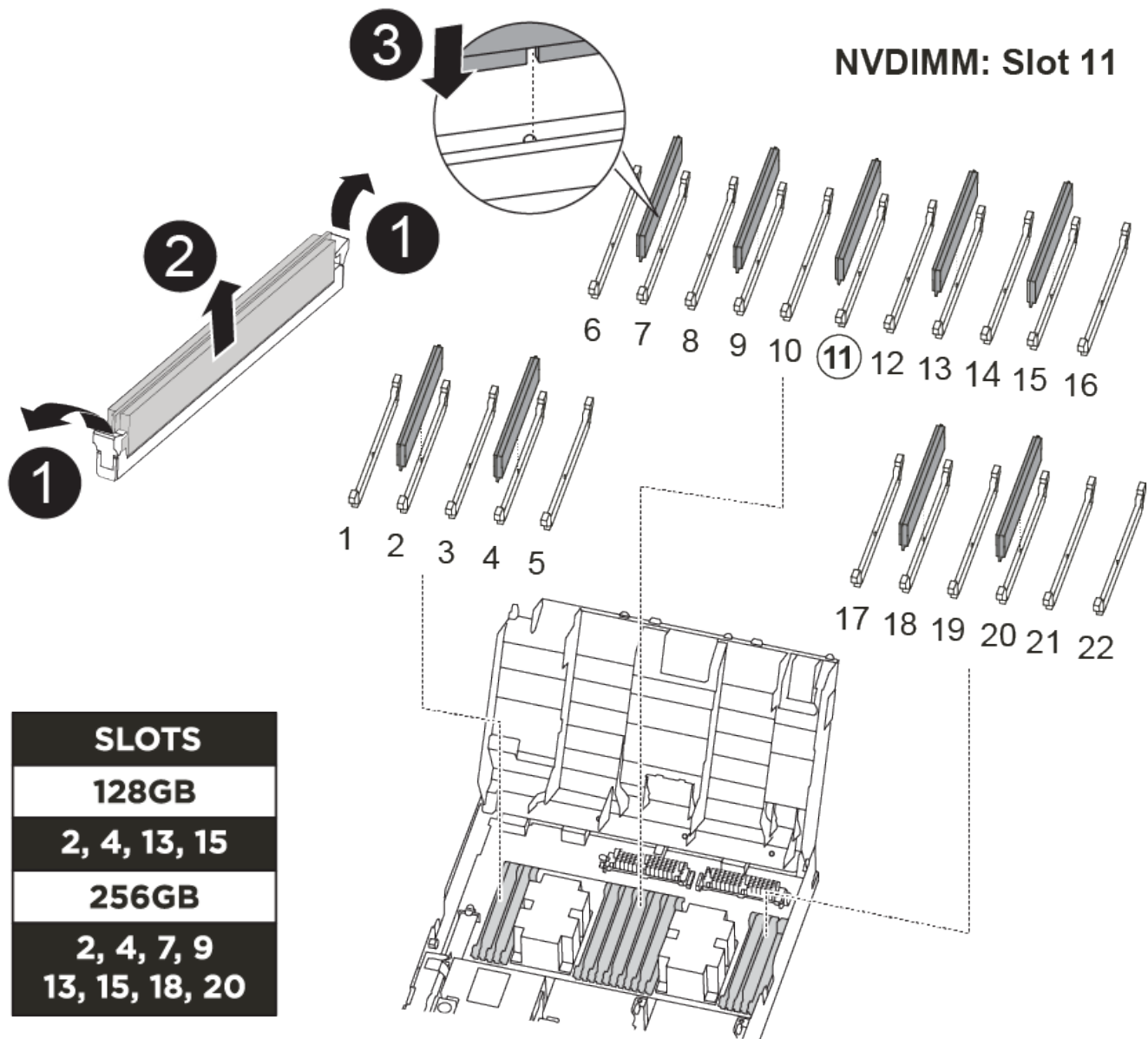

The DIMMs are located in sockets 2, 4, 13, and 15. The NVDIMM is located in slot 11.

1. Open the air duct:

- Press the locking tabs on the sides of the air duct in toward the middle of the controller module.
- Slide the air duct toward the back of the controller module, and then rotate it upward to its completely open position.

2. Locate the DIMMs on your controller module.
3. Note the orientation of the DIMM in the socket so that you can insert the replacement DIMM in the proper orientation.
4. Eject the DIMM from its socket by slowly pushing apart the two DIMM ejector tabs on either side of the DIMM, and then slide the DIMM out of the socket.



Carefully hold the DIMM by the edges to avoid pressure on the components on the DIMM circuit board.

5. Remove the replacement DIMM from the antistatic shipping bag, hold the DIMM by the corners, and align it to the slot.

The notch among the pins on the DIMM should line up with the tab in the socket.

6. Make sure that the DIMM ejector tabs on the connector are in the open position, and then insert the DIMM squarely into the slot.

The DIMM fits tightly in the slot, but should go in easily. If not, realign the DIMM with the slot and reinsert it.



Visually inspect the DIMM to verify that it is evenly aligned and fully inserted into the slot.

7. Push carefully, but firmly, on the top edge of the DIMM until the ejector tabs snap into place over the notches at the ends of the DIMM.
8. Close the air duct.

#### Step 4: Install the controller module

After you have replaced the component in the controller module, you must reinstall the controller module into the chassis, and then boot it to Maintenance mode.

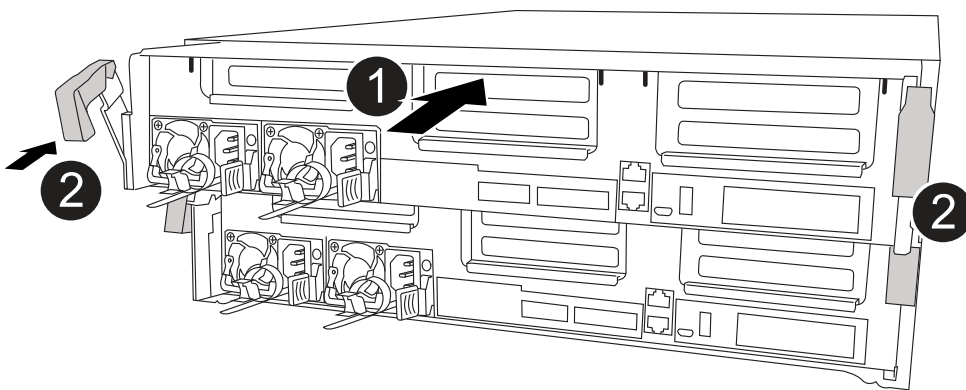

<b>1</b>	Controller module
<b>2</b>	Controller locking latches

1. If you have not already done so, close the air duct.
2. Align the end of the controller module with the opening in the chassis, and then gently push the controller module halfway into the system.



Do not completely insert the controller module in the chassis until instructed to do so.

3. Cable the management and console ports only, so that you can access the system to perform the tasks in the following sections.



You will connect the rest of the cables to the controller module later in this procedure.

4. Complete the installation of the controller module:
  - a. Plug the power cord into the power supply, reinstall the power cable locking collar, and then connect the power supply to the power source.
  - b. Using the locking latches, firmly push the controller module into the chassis until the locking latches begin to rise.



Do not use excessive force when sliding the controller module into the chassis to avoid damaging the connectors.

- c. Fully seat the controller module in the chassis by rotating the locking latches upward, tilting them so that they clear the locking pins, gently push the controller all the way in, and then lower the locking latches into the locked position.

The controller module begins to boot as soon as it is fully seated in the chassis. Be prepared to interrupt the boot process.

- d. If you have not already done so, reinstall the cable management device.
- e. Interrupt the normal boot process and boot to LOADER by pressing `Ctrl-C`.



If your system stops at the boot menu, select the option to boot to LOADER.

- f. At the LOADER prompt, enter `bye` to reinitialize the PCIe cards and other components.
- g. Interrupt the boot process and boot to the LOADER prompt by pressing `Ctrl-C`.

If your system stops at the boot menu, select the option to boot to LOADER.

## Step 5: Restore the controller module to operation

You must recable the system, give back the controller module, and then reenabling automatic giveback.

1. Recable the system, as needed.

If you removed the media converters (QSFPs or SFPs), remember to reinstall them if you are using fiber optic cables.

2. Return the controller to normal operation by giving back its storage: `storage failover giveback -ofnode impaired_node_name`
3. If automatic giveback was disabled, reenabling it: `storage failover modify -node local -auto`

```
-giveback true
```

## Step 6: Switch back aggregates in a two-node MetroCluster configuration

After you have completed the FRU replacement in a two-node MetroCluster configuration, you can perform the MetroCluster switchback operation. This returns the configuration to its normal operating state, with the sync-source storage virtual machines (SVMs) on the formerly impaired site now active and serving data from the local disk pools.

This task only applies to two-node MetroCluster configurations.

### Steps

1. Verify that all nodes are in the enabled state: `metrocluster node show`

```
cluster_B::> metrocluster node show

DR                               Configuration  DR
Group Cluster Node              State          Mirroring Mode
-----
1      cluster_A
      controller_A_1 configured      enabled      heal roots
completed
      cluster_B
      controller_B_1 configured      enabled      waiting for
switchback recovery
2 entries were displayed.
```

2. Verify that resynchronization is complete on all SVMs: `metrocluster vserver show`
3. Verify that any automatic LIF migrations being performed by the healing operations were completed successfully: `metrocluster check lif show`
4. Perform the switchback by using the `metrocluster switchback` command from any node in the surviving cluster.
5. Verify that the switchback operation has completed: `metrocluster show`

The switchback operation is still running when a cluster is in the `waiting-for-switchback` state:

```
cluster_B::> metrocluster show

Cluster              Configuration State      Mode
-----
Local: cluster_B configured      switchover
Remote: cluster_A configured      waiting-for-switchback
```

The switchback operation is complete when the clusters are in the `normal` state.:

```

cluster_B::> metrocluster show
Cluster              Configuration State      Mode
-----
Local: cluster_B configured          normal
Remote: cluster_A configured          normal

```

If a switchback is taking a long time to finish, you can check on the status of in-progress baselines by using the `metrocluster config-replication resync-status show` command.

6. Reestablish any SnapMirror or SnapVault configurations.

### Step 7: Return the failed part to NetApp

Return the failed part to NetApp, as described in the RMA instructions shipped with the kit. See the [Part Return and Replacements](#) page for further information.

#### Hot-swap a fan module - ASA C400

To swap out a fan module without interrupting service, you must perform a specific sequence of tasks.



You must replace the fan module within two minutes of removing it from the chassis. System airflow is disrupted and the controller module or modules shut down after two minutes to avoid overheating.

You can use the following animation, illustration, or the written steps to hot-swap a fan module.

[Animation - Replace a fan](#)

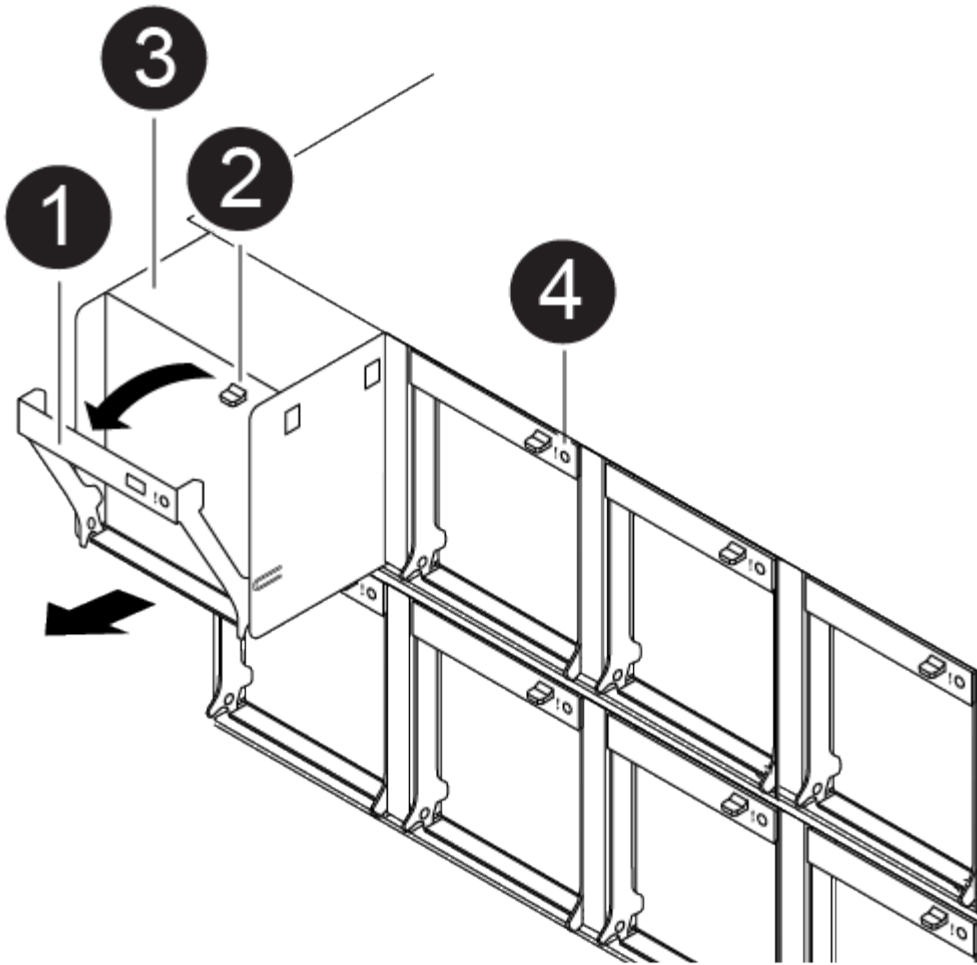

1	Fan handle
2	Locking tab
3	Fan
4	Status LED

1. If you are not already grounded, properly ground yourself.
2. Remove the bezel (if necessary) with two hands, by grasping the openings on each side of the bezel, and then pulling it toward you until the bezel releases from the ball studs on the chassis frame.
3. Identify the fan module that you must replace by checking the console error messages and looking at the Attention LED on each fan module.
4. Press down the release latch on the fan module cam handle, and then rotate the cam handle downward.

The fan module moves a little bit away from the chassis.



5. Pull the fan module straight out from the chassis, making sure that you support it with your free hand so that it does not swing out of the chassis.



The fan modules are short. Always support the bottom of the fan module with your free hand so that it does not suddenly drop free from the chassis and injure you.

6. Set the fan module aside.
7. Insert the replacement fan module into the chassis by aligning it with the opening, and then sliding it into the chassis.
8. Push firmly on the fan module cam handle so that it is seated all the way into the chassis.

The cam handle raises slightly when the fan module is completely seated.

9. Swing the cam handle up to its closed position, making sure that the cam handle release latch clicks into the locked position.

The Attention LED should not be lit after the fan is seated and has spun up to operational speed.

10. Align the bezel with the ball studs, and then gently push the bezel onto the ball studs.
11. Return the failed part to NetApp, as described in the RMA instructions shipped with the kit. See the [Part Return and Replacements](#) page for further information.

#### **Replace the NVDIMM battery - ASA C400**

To replace the NVDIMM battery, you must remove the controller module, remove the battery, replace the battery, and then reinstall the controller module.

All other components in the system must be functioning properly; if not, you must contact technical support.

#### **Step 1: Shut down the impaired controller**

You can shut down or take over the impaired controller using different procedures, depending on the storage system hardware configuration.

### Option 1: Most configurations

To shut down the impaired controller, you must determine the status of the controller and, if necessary, take over the controller so that the healthy controller continues to serve data from the impaired controller storage.

#### About this task

- If you have a SAN system, you must have checked event messages (`cluster kernel-service show`) for the impaired controller SCSI blade. The `cluster kernel-service show` command (from `priv advanced` mode) displays the node name, quorum status of that node, availability status of that node, and operational status of that node.

Each SCSI-blade process should be in quorum with the other nodes in the cluster. Any issues must be resolved before you proceed with the replacement.

- If you have a cluster with more than two nodes, it must be in quorum. If the cluster is not in quorum or a healthy controller shows false for eligibility and health, you must correct the issue before shutting down the impaired controller; see [Synchronize a node with the cluster](#).

#### Steps

1. If AutoSupport is enabled, suppress automatic case creation by invoking an AutoSupport message:

```
system node autosupport invoke -node * -type all -message MAINT=<# of hours>h
```

The following AutoSupport message suppresses automatic case creation for two hours: `cluster1:>`

```
system node autosupport invoke -node * -type all -message MAINT=2h
```

2. Disable automatic giveback from the console of the healthy controller: `storage failover modify -node local -auto-giveback false`



When you see *Do you want to disable auto-giveback?*, enter *y*.

3. Take the impaired controller to the LOADER prompt:

If the impaired controller is displaying...	Then...
The LOADER prompt	Go to the next step.
Waiting for giveback...	Press Ctrl-C, and then respond <i>y</i> when prompted.
System prompt or password prompt	Take over or halt the impaired controller from the healthy controller: <code>storage failover takeover -ofnode <i>impaired_node_name</i></code>  When the impaired controller shows Waiting for giveback..., press Ctrl-C, and then respond <i>y</i> .

### Option 2: Controller is in a two-node MetroCluster

To shut down the impaired controller, you must determine the status of the controller and, if necessary,

switch over the controller so that the healthy controller continues to serve data from the impaired controller storage.

### About this task

- You must leave the power supplies turned on at the end of this procedure to provide power to the healthy controller.

### Steps

1. Check the MetroCluster status to determine whether the impaired controller has automatically switched over to the healthy controller: `metrocluster show`
2. Depending on whether an automatic switchover has occurred, proceed according to the following table:

If the impaired controller...	Then...
Has automatically switched over	Proceed to the next step.
Has not automatically switched over	Perform a planned switchover operation from the healthy controller: <code>metrocluster switchover</code>
Has not automatically switched over, you attempted switchover with the <code>metrocluster switchover</code> command, and the switchover was vetoed	Review the veto messages and, if possible, resolve the issue and try again. If you are unable to resolve the issue, contact technical support.

3. Resynchronize the data aggregates by running the `metrocluster heal -phase aggregates` command from the surviving cluster.

```
controller_A_1::> metrocluster heal -phase aggregates
[Job 130] Job succeeded: Heal Aggregates is successful.
```

If the healing is vetoed, you have the option of reissuing the `metrocluster heal` command with the `-override-vetoes` parameter. If you use this optional parameter, the system overrides any soft vetoes that prevent the healing operation.

4. Verify that the operation has been completed by using the `metrocluster operation show` command.

```
controller_A_1::> metrocluster operation show
  Operation: heal-aggregates
  State: successful
Start Time: 7/25/2016 18:45:55
End Time: 7/25/2016 18:45:56
Errors: -
```

5. Check the state of the aggregates by using the `storage aggregate show` command.

```

controller_A_1::> storage aggregate show
Aggregate      Size Available Used% State   #Vols  Nodes
RAID Status
-----
...
aggr_b2      227.1GB   227.1GB   0% online    0 mcc1-a2
raid_dp, mirrored, normal...

```

6. Heal the root aggregates by using the `metrocluster heal -phase root-aggregates` command.

```

mcc1A::> metrocluster heal -phase root-aggregates
[Job 137] Job succeeded: Heal Root Aggregates is successful

```

If the healing is vetoed, you have the option of reissuing the `metrocluster heal` command with the `-override-vetoes` parameter. If you use this optional parameter, the system overrides any soft vetoes that prevent the healing operation.

7. Verify that the heal operation is complete by using the `metrocluster operation show` command on the destination cluster:

```

mcc1A::> metrocluster operation show
Operation: heal-root-aggregates
State: successful
Start Time: 7/29/2016 20:54:41
End Time: 7/29/2016 20:54:42
Errors: -

```

8. On the impaired controller module, disconnect the power supplies.

## Step 2: Remove the controller module

To access components inside the controller module, you must remove the controller module from the chassis.

1. If you are not already grounded, properly ground yourself.
2. Release the power cable retainers, and then unplug the cables from the power supplies.
3. Loosen the hook and loop strap binding the cables to the cable management device, and then unplug the system cables and SFPs (if needed) from the controller module, keeping track of where the cables were connected.

Leave the cables in the cable management device so that when you reinstall the cable management device, the cables are organized.

4. Remove the cable management device from the controller module and set it aside.

5. Press down on both of the locking latches, and then rotate both latches downward at the same time.

The controller module moves slightly out of the chassis.

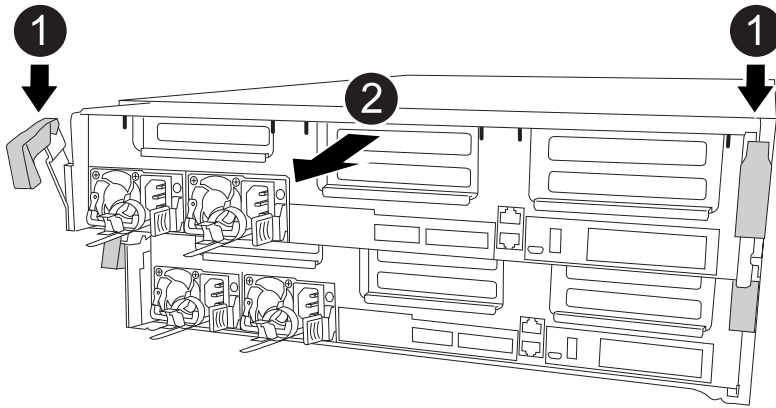

1	Locking latches
2	Controller moves slightly out of chassis

6. Slide the controller module out of the chassis.

Make sure that you support the bottom of the controller module as you slide it out of the chassis.

7. Place the controller module on a stable, flat surface.

### Step 3: Replace the NVDIMM battery

To replace the NVDIMM battery, you must remove the failed battery from the controller module and install the replacement battery into the controller module. See the FRU map inside the controller module to locate the NVDIMM battery.

The NVDIMM LED blinks while destaging contents when you halt the system. After the destage is complete, the LED turns off.

You can use the following animation, illustration, or the written steps to replace the NVDIMM battery.

[Animation - Replace the NVDIMM battery](#)

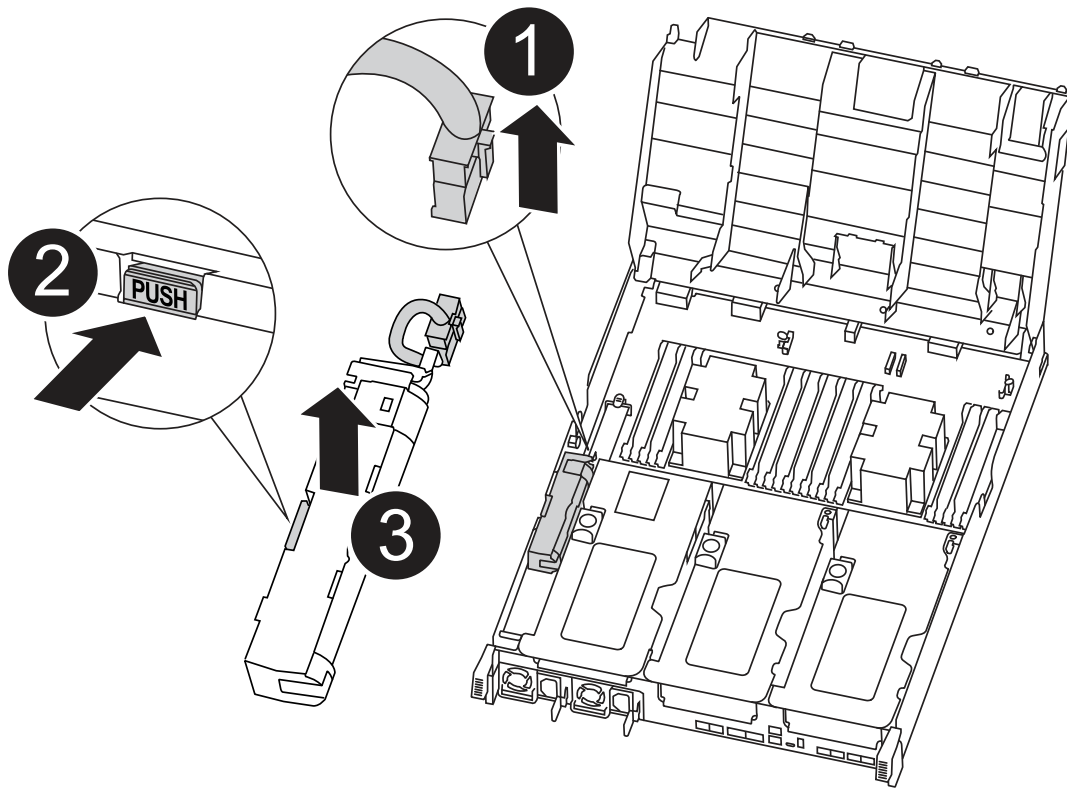

1	Battery plug
2	Locking tab
3	NVDIMM battery

1. Open the air duct:
  - a. Press the locking tabs on the sides of the air duct in toward the middle of the controller module.
  - b. Slide the air duct toward the back of the controller module, and then rotate it upward to its completely open position.
2. Locate the NVDIMM battery in the controller module.
3. Locate the battery plug and squeeze the clip on the face of the battery plug to release the plug from the socket, and then unplug the battery cable from the socket.
4. Grasp the battery and press the blue locking tab marked PUSH, and then lift the battery out of the holder and controller module.
5. Remove the replacement battery from its package.
6. Align the battery module with the opening for the battery, and then gently push the battery into slot until it locks into place.
7. Plug the battery plug back into the controller module, and then close the air duct.

#### Step 4: Install the controller module

After you have replaced the component in the controller module, you must reinstall the controller module into the chassis, and then boot it to Maintenance mode.

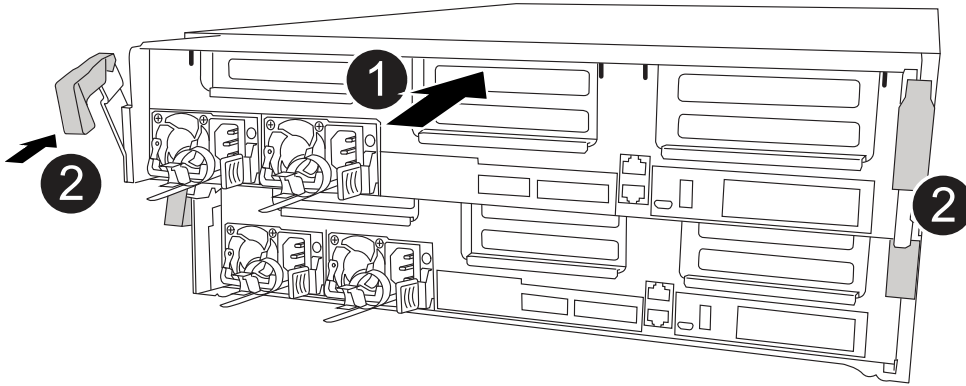

<b>1</b>	Controller module
<b>2</b>	Controller locking latches

1. If you have not already done so, close the air duct.
2. Align the end of the controller module with the opening in the chassis, and then gently push the controller module halfway into the system.



Do not completely insert the controller module in the chassis until instructed to do so.

3. Cable the management and console ports only, so that you can access the system to perform the tasks in the following sections.



You will connect the rest of the cables to the controller module later in this procedure.

4. Complete the installation of the controller module:
  - a. Plug the power cord into the power supply, reinstall the power cable locking collar, and then connect the power supply to the power source.
  - b. Using the locking latches, firmly push the controller module into the chassis until the locking latches begin to rise.



Do not use excessive force when sliding the controller module into the chassis to avoid damaging the connectors.

- c. Fully seat the controller module in the chassis by rotating the locking latches upward, tilting them so that they clear the locking pins, gently push the controller all the way in, and then lower the locking latches into the locked position.

The controller module begins to boot as soon as it is fully seated in the chassis. Be prepared to

interrupt the boot process.

- d. If you have not already done so, reinstall the cable management device.
- e. Interrupt the normal boot process and boot to LOADER by pressing `Ctrl-C`.



If your system stops at the boot menu, select the option to boot to LOADER.

- f. At the LOADER prompt, enter `bye` to reinitialize the PCIe cards and other components.
- g. Interrupt the boot process and boot to the LOADER prompt by pressing `Ctrl-C`.

If your system stops at the boot menu, select the option to boot to LOADER.

### Step 5: Restore the controller module to operation

You must recable the system, give back the controller module, and then reenabling automatic giveback.

1. Recable the system, as needed.

If you removed the media converters (QSFPs or SFPs), remember to reinstall them if you are using fiber optic cables.

2. Return the controller to normal operation by giving back its storage: `storage failover giveback -ofnode impaired_node_name`
3. If automatic giveback was disabled, reenabling it: `storage failover modify -node local -auto-giveback true`

### Step 6: Switch back aggregates in a two-node MetroCluster configuration

After you have completed the FRU replacement in a two-node MetroCluster configuration, you can perform the MetroCluster switchback operation. This returns the configuration to its normal operating state, with the sync-source storage virtual machines (SVMs) on the formerly impaired site now active and serving data from the local disk pools.

This task only applies to two-node MetroCluster configurations.

#### Steps

1. Verify that all nodes are in the enabled state: `metrocluster node show`



```

cluster_B::> metrocluster node show

DR
Group Cluster Node          Configuration  DR
-----
-----
1      cluster_A
      controller_A_1 configured    enabled    heal roots
completed
      cluster_B
      controller_B_1 configured    enabled    waiting for
switchback recovery
2 entries were displayed.

```

2. Verify that resynchronization is complete on all SVMs: `metrocluster vserver show`
3. Verify that any automatic LIF migrations being performed by the healing operations were completed successfully: `metrocluster check lif show`
4. Perform the switchback by using the `metrocluster switchback` command from any node in the surviving cluster.
5. Verify that the switchback operation has completed: `metrocluster show`

The switchback operation is still running when a cluster is in the `waiting-for-switchback` state:

```

cluster_B::> metrocluster show
Cluster          Configuration State      Mode
-----
Local: cluster_B configured    switchover
Remote: cluster_A configured    waiting-for-switchback

```

The switchback operation is complete when the clusters are in the `normal` state.:

```

cluster_B::> metrocluster show
Cluster          Configuration State      Mode
-----
Local: cluster_B configured    normal
Remote: cluster_A configured    normal

```

If a switchback is taking a long time to finish, you can check on the status of in-progress baselines by using the `metrocluster config-replication resync-status show` command.

6. Reestablish any SnapMirror or SnapVault configurations.

### **Step 7: Return the failed part to NetApp**

Return the failed part to NetApp, as described in the RMA instructions shipped with the kit. See the [Part Return and Replacements](#) page for further information.

#### **Replace an NVDIMM - ASA C400**

You must replace the NVDIMM in the controller module when your system registers that the flash lifetime is almost at an end or that the identified NVDIMM is not healthy in general; failure to do so causes a system panic.

All other components in the system must be functioning properly; if not, you must contact technical support.

You must replace the failed component with a replacement FRU component you received from your provider.

#### **Step 1: Shut down the impaired controller**

Shut down or take over the impaired controller using the appropriate procedure for your configuration.

### Option 1: Most configurations

To shut down the impaired controller, you must determine the status of the controller and, if necessary, take over the controller so that the healthy controller continues to serve data from the impaired controller storage.

#### About this task

- If you have a SAN system, you must have checked event messages (`cluster kernel-service show`) for the impaired controller SCSI blade. The `cluster kernel-service show` command (from `priv advanced` mode) displays the node name, quorum status of that node, availability status of that node, and operational status of that node.

Each SCSI-blade process should be in quorum with the other nodes in the cluster. Any issues must be resolved before you proceed with the replacement.

- If you have a cluster with more than two nodes, it must be in quorum. If the cluster is not in quorum or a healthy controller shows false for eligibility and health, you must correct the issue before shutting down the impaired controller; see [Synchronize a node with the cluster](#).

#### Steps

1. If AutoSupport is enabled, suppress automatic case creation by invoking an AutoSupport message:

```
system node autosupport invoke -node * -type all -message MAINT=<# of hours>h
```

The following AutoSupport message suppresses automatic case creation for two hours: `cluster1:>`

```
system node autosupport invoke -node * -type all -message MAINT=2h
```

2. Disable automatic giveback from the console of the healthy controller: `storage failover modify -node local -auto-giveback false`



When you see *Do you want to disable auto-giveback?*, enter *y*.

3. Take the impaired controller to the LOADER prompt:

If the impaired controller is displaying...	Then...
The LOADER prompt	Go to the next step.
Waiting for giveback...	Press Ctrl-C, and then respond <i>y</i> when prompted.
System prompt or password prompt	Take over or halt the impaired controller from the healthy controller: <code>storage failover takeover -ofnode <i>impaired_node_name</i></code>  When the impaired controller shows Waiting for giveback..., press Ctrl-C, and then respond <i>y</i> .

### Option 2: Controller is in a two-node MetroCluster

To shut down the impaired controller, you must determine the status of the controller and, if necessary,

switch over the controller so that the healthy controller continues to serve data from the impaired controller storage.

### About this task

- You must leave the power supplies turned on at the end of this procedure to provide power to the healthy controller.

### Steps

1. Check the MetroCluster status to determine whether the impaired controller has automatically switched over to the healthy controller: `metrocluster show`
2. Depending on whether an automatic switchover has occurred, proceed according to the following table:

If the impaired controller...	Then...
Has automatically switched over	Proceed to the next step.
Has not automatically switched over	Perform a planned switchover operation from the healthy controller: <code>metrocluster switchover</code>
Has not automatically switched over, you attempted switchover with the <code>metrocluster switchover</code> command, and the switchover was vetoed	Review the veto messages and, if possible, resolve the issue and try again. If you are unable to resolve the issue, contact technical support.

3. Resynchronize the data aggregates by running the `metrocluster heal -phase aggregates` command from the surviving cluster.

```
controller_A_1::> metrocluster heal -phase aggregates
[Job 130] Job succeeded: Heal Aggregates is successful.
```

If the healing is vetoed, you have the option of reissuing the `metrocluster heal` command with the `-override-vetoes` parameter. If you use this optional parameter, the system overrides any soft vetoes that prevent the healing operation.

4. Verify that the operation has been completed by using the `metrocluster operation show` command.

```
controller_A_1::> metrocluster operation show
  Operation: heal-aggregates
  State: successful
Start Time: 7/25/2016 18:45:55
End Time: 7/25/2016 18:45:56
Errors: -
```

5. Check the state of the aggregates by using the `storage aggregate show` command.

```

controller_A_1::> storage aggregate show
Aggregate      Size Available Used% State   #Vols  Nodes
RAID Status
-----
...
aggr_b2       227.1GB   227.1GB   0% online    0 mcc1-a2
raid_dp, mirrored, normal...

```

6. Heal the root aggregates by using the `metrocluster heal -phase root-aggregates` command.

```

mcc1A::> metrocluster heal -phase root-aggregates
[Job 137] Job succeeded: Heal Root Aggregates is successful

```

If the healing is vetoed, you have the option of reissuing the `metrocluster heal` command with the `-override-vetoes` parameter. If you use this optional parameter, the system overrides any soft vetoes that prevent the healing operation.

7. Verify that the heal operation is complete by using the `metrocluster operation show` command on the destination cluster:

```

mcc1A::> metrocluster operation show
Operation: heal-root-aggregates
State: successful
Start Time: 7/29/2016 20:54:41
End Time: 7/29/2016 20:54:42
Errors: -

```

8. On the impaired controller module, disconnect the power supplies.

## Step 2: Remove the controller module

To access components inside the controller module, you must remove the controller module from the chassis.

1. If you are not already grounded, properly ground yourself.
2. Release the power cable retainers, and then unplug the cables from the power supplies.
3. Loosen the hook and loop strap binding the cables to the cable management device, and then unplug the system cables and SFPs (if needed) from the controller module, keeping track of where the cables were connected.

Leave the cables in the cable management device so that when you reinstall the cable management device, the cables are organized.

4. Remove the cable management device from the controller module and set it aside.

5. Press down on both of the locking latches, and then rotate both latches downward at the same time.

The controller module moves slightly out of the chassis.

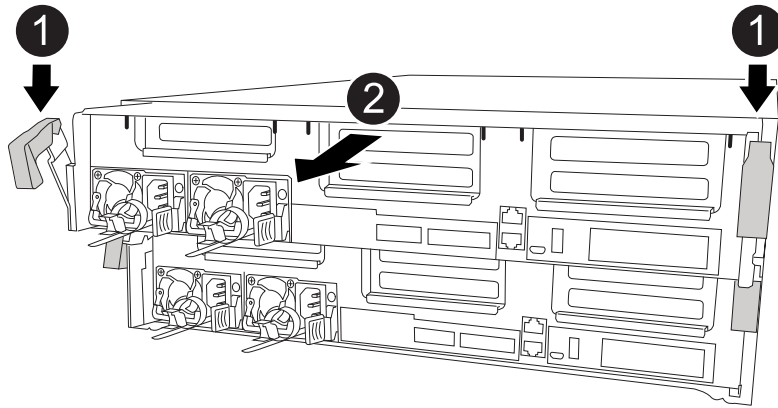

<b>1</b>	Locking latches
<b>2</b>	Controller moves slightly out of chassis

6. Slide the controller module out of the chassis.

Make sure that you support the bottom of the controller module as you slide it out of the chassis.

7. Place the controller module on a stable, flat surface.

### Step 3: Replace the NVDIMM

To replace the NVDIMM, you must locate it in the controller module using the FRU map on top of the air duct or the FRU Map on the top of the slot 1 riser.

- The NVDIMM LED blinks while destaging contents when you halt the system. After the destage is complete, the LED turns off.
- Although the contents of the NVDIMM is encrypted, it is a best practice to erase the contents of the NVDIMM before replacing it. For more information, see the [Statement of Volatility](#) on the NetApp Support Site.



You must log into the NetApp Support Site to display the *Statement of Volatility* for your system.

You can use the following animation, illustration, or the written steps to replace the NVDIMM.



The animation shows empty slots for sockets without DIMMs. These empty sockets are populated with blanks.

[Animation - Replace the NVDIMM](#)

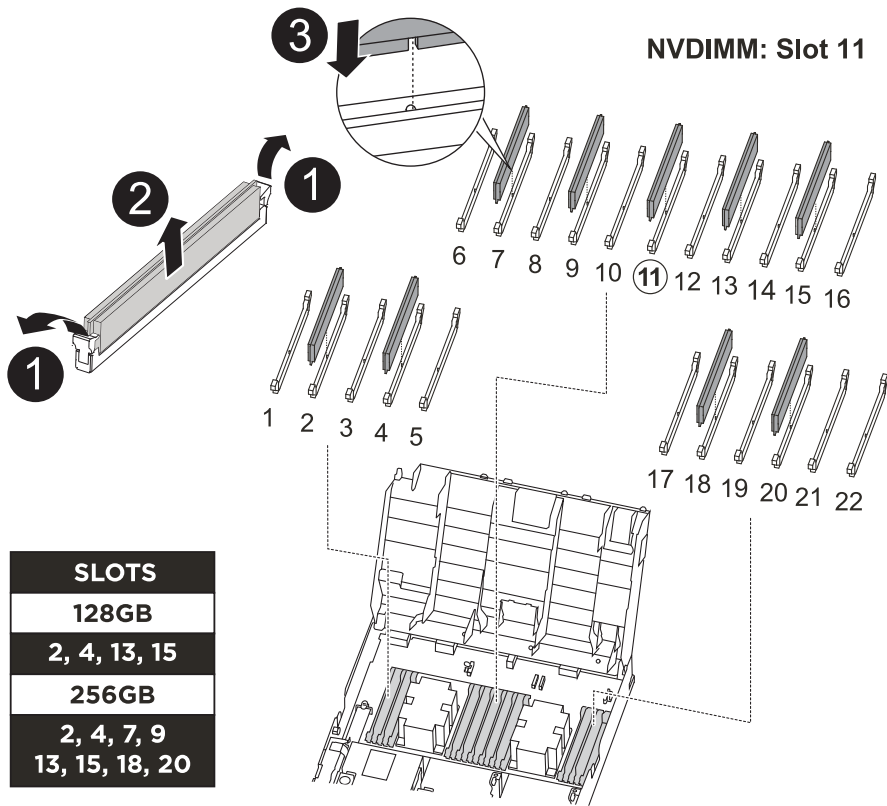

<b>1</b>	DIMM locking tabs
<b>2</b>	DIMM
<b>3</b>	DIMM socket

1. Open the air duct and then locate the NVDIMM in slot 11 on your controller module.



The NVDIMM looks significantly different than system DIMMs.

2. Eject the NVDIMM from its slot by slowly pushing apart the two NVDIMM ejector tabs on either side of the NVDIMM, and then slide the NVDIMM out of the socket and set it aside.



Carefully hold the NVDIMM by the edges to avoid pressure on the components on the NVDIMM circuit board.

3. Remove the replacement NVDIMM from the antistatic shipping bag, hold the NVDIMM by the corners, and then align it to the slot.

The notch among the pins on the NVDIMM should line up with the tab in the socket.

4. Locate the slot where you are installing the NVDIMM.

5. Insert the NVDIMM squarely into the slot.

The NVDIMM fits tightly in the slot, but should go in easily. If not, realign the NVDIMM with the slot and

reinsert it.



Visually inspect the NVDIMM to verify that it is evenly aligned and fully inserted into the slot.

6. Push carefully, but firmly, on the top edge of the NVDIMM until the ejector tabs snap into place over the notches at the ends of the NVDIMM.
7. Close the air duct.

#### Step 4: Install the controller module

After you have replaced the component in the controller module, you must reinstall the controller module into the chassis, and then boot it to Maintenance mode.

1. If you have not already done so, close the air duct.
2. Align the end of the controller module with the opening in the chassis, and then gently push the controller module halfway into the system.



Do not completely insert the controller module in the chassis until instructed to do so.

3. Cable the management and console ports only, so that you can access the system to perform the tasks in the following sections.



You will connect the rest of the cables to the controller module later in this procedure.

4. Complete the installation of the controller module:
  - a. Plug the power cord into the power supply, reinstall the power cable locking collar, and then connect the power supply to the power source.
  - b. Using the locking latches, firmly push the controller module into the chassis until the locking latches begin to rise.



Do not use excessive force when sliding the controller module into the chassis to avoid damaging the connectors.

- c. Fully seat the controller module in the chassis by rotating the locking latches upward, tilting them so that they clear the locking pins, gently push the controller all the way in, and then lower the locking latches into the locked position.

The controller module begins to boot as soon as it is fully seated in the chassis. Be prepared to interrupt the boot process.

- d. If you have not already done so, reinstall the cable management device.
  - e. Interrupt the normal boot process and boot to LOADER by pressing `Ctrl-C`.



If your system stops at the boot menu, select the option to boot to LOADER.

- f. At the LOADER prompt, enter `bye` to reinitialize the PCIe cards and other components.
  - g. Interrupt the boot process and boot to the LOADER prompt by pressing `Ctrl-C`.

If your system stops at the boot menu, select the option to boot to LOADER.



## Step 5: Restore the controller module to operation

You must recable the system, give back the controller module, and then reenabling automatic giveback.

1. Recable the system, as needed.

If you removed the media converters (QSFPs or SFPs), remember to reinstall them if you are using fiber optic cables.

2. Return the controller to normal operation by giving back its storage: `storage failover giveback -ofnode impaired_node_name`
3. If automatic giveback was disabled, reenabling it: `storage failover modify -node local -auto-giveback true`

## Step 6: Switch back aggregates in a two-node MetroCluster configuration

After you have completed the FRU replacement in a two-node MetroCluster configuration, you can perform the MetroCluster switchback operation. This returns the configuration to its normal operating state, with the sync-source storage virtual machines (SVMs) on the formerly impaired site now active and serving data from the local disk pools.

This task only applies to two-node MetroCluster configurations.

### Steps

1. Verify that all nodes are in the enabled state: `metrocluster node show`

```
cluster_B::> metrocluster node show

DR                               Configuration  DR
Group Cluster Node              State          Mirroring Mode
-----
1      cluster_A
      controller_A_1 configured    enabled    heal roots
completed
      cluster_B
      controller_B_1 configured    enabled    waiting for
switchback recovery
2 entries were displayed.
```

2. Verify that resynchronization is complete on all SVMs: `metrocluster vserver show`
3. Verify that any automatic LIF migrations being performed by the healing operations were completed successfully: `metrocluster check lif show`
4. Perform the switchback by using the `metrocluster switchback` command from any node in the surviving cluster.
5. Verify that the switchback operation has completed: `metrocluster show`

The switchback operation is still running when a cluster is in the `waiting-for-switchback` state:

```

cluster_B::> metrocluster show
Cluster          Configuration State      Mode
-----
Local: cluster_B configured      switchover
Remote: cluster_A configured      waiting-for-switchback

```

The switchback operation is complete when the clusters are in the normal state.:

```

cluster_B::> metrocluster show
Cluster          Configuration State      Mode
-----
Local: cluster_B configured      normal
Remote: cluster_A configured      normal

```

If a switchback is taking a long time to finish, you can check on the status of in-progress baselines by using the `metrocluster config-replication resync-status show` command.

6. Reestablish any SnapMirror or SnapVault configurations.

### Step 7: Return the failed part to NetApp

Return the failed part to NetApp, as described in the RMA instructions shipped with the kit. See the [Part Return and Replacements](#) page for further information.

#### Replace a PCIe or mezzanine card - ASA C400

To replace a PCIe or mezzanine card, you must disconnect the cables and any SFP and QSFP modules from the cards, replace the failed PCIe or mezzanine card, and then recable the cards.

- You can use this procedure with all versions of ONTAP supported by your system
- All other components in the system must be functioning properly; if not, you must contact technical support.

#### Step 1: Shut down the impaired controller

You can shut down or take over the impaired controller using different procedures, depending on the storage system hardware configuration.

### Option 1: Most configurations

To shut down the impaired controller, you must determine the status of the controller and, if necessary, take over the controller so that the healthy controller continues to serve data from the impaired controller storage.

#### About this task

- If you have a SAN system, you must have checked event messages (`cluster kernel-service show`) for the impaired controller SCSI blade. The `cluster kernel-service show` command (from `priv advanced` mode) displays the node name, quorum status of that node, availability status of that node, and operational status of that node.

Each SCSI-blade process should be in quorum with the other nodes in the cluster. Any issues must be resolved before you proceed with the replacement.

- If you have a cluster with more than two nodes, it must be in quorum. If the cluster is not in quorum or a healthy controller shows `false` for eligibility and health, you must correct the issue before shutting down the impaired controller; see [Synchronize a node with the cluster](#).

#### Steps

1. If AutoSupport is enabled, suppress automatic case creation by invoking an AutoSupport message:

```
system node autosupport invoke -node * -type all -message MAINT=<# of hours>h
```

The following AutoSupport message suppresses automatic case creation for two hours: `cluster1:> system node autosupport invoke -node * -type all -message MAINT=2h`

2. Disable automatic giveback from the console of the healthy controller: `storage failover modify -node local -auto-giveback false`



When you see *Do you want to disable auto-giveback?*, enter *y*.

3. Take the impaired controller to the LOADER prompt:

If the impaired controller is displaying...	Then...
The LOADER prompt	Go to the next step.
Waiting for giveback...	Press Ctrl-C, and then respond <i>y</i> when prompted.
System prompt or password prompt	Take over or halt the impaired controller from the healthy controller: <code>storage failover takeover -ofnode <i>impaired_node_name</i></code>  When the impaired controller shows <code>Waiting for giveback...</code> , press Ctrl-C, and then respond <i>y</i> .

### Option 2: Controller is in a two-node MetroCluster

To shut down the impaired controller, you must determine the status of the controller and, if necessary, switch over the controller so that the healthy controller continues to serve data from the impaired controller storage.

#### About this task

- You must leave the power supplies turned on at the end of this procedure to provide power to the healthy controller.

#### Steps

1. Check the MetroCluster status to determine whether the impaired controller has automatically switched over to the healthy controller: `metrocluster show`
2. Depending on whether an automatic switchover has occurred, proceed according to the following table:

If the impaired controller...	Then...
Has automatically switched over	Proceed to the next step.
Has not automatically switched over	Perform a planned switchover operation from the healthy controller: <code>metrocluster switchover</code>
Has not automatically switched over, you attempted switchover with the <code>metrocluster switchover</code> command, and the switchover was vetoed	Review the veto messages and, if possible, resolve the issue and try again. If you are unable to resolve the issue, contact technical support.

3. Resynchronize the data aggregates by running the `metrocluster heal -phase aggregates` command from the surviving cluster.

```
controller_A_1::> metrocluster heal -phase aggregates
[Job 130] Job succeeded: Heal Aggregates is successful.
```

If the healing is vetoed, you have the option of reissuing the `metrocluster heal` command with the `-override-vetoes` parameter. If you use this optional parameter, the system overrides any soft vetoes that prevent the healing operation.

4. Verify that the operation has been completed by using the `metrocluster operation show` command.

```
controller_A_1::> metrocluster operation show
  Operation: heal-aggregates
    State: successful
Start Time: 7/25/2016 18:45:55
End Time: 7/25/2016 18:45:56
Errors: -
```

5. Check the state of the aggregates by using the `storage aggregate show` command.

```
controller_A_1::> storage aggregate show
Aggregate      Size Available Used% State   #Vols  Nodes
RAID Status
-----
...
aggr_b2       227.1GB   227.1GB   0% online    0  mcc1-a2
raid_dp, mirrored, normal...
```

6. Heal the root aggregates by using the `metrocluster heal -phase root-aggregates` command.

```
mcc1A::> metrocluster heal -phase root-aggregates
[Job 137] Job succeeded: Heal Root Aggregates is successful
```

If the healing is vetoed, you have the option of reissuing the `metrocluster heal` command with the `-override-vetoes` parameter. If you use this optional parameter, the system overrides any soft vetoes that prevent the healing operation.

7. Verify that the heal operation is complete by using the `metrocluster operation show` command on the destination cluster:

```
mcc1A::> metrocluster operation show
Operation: heal-root-aggregates
State: successful
Start Time: 7/29/2016 20:54:41
End Time: 7/29/2016 20:54:42
Errors: -
```

8. On the impaired controller module, disconnect the power supplies.

## Step 2: Remove the controller module

To access components inside the controller module, you must remove the controller module from the chassis.

1. If you are not already grounded, properly ground yourself.
2. Release the power cable retainers, and then unplug the cables from the power supplies.
3. Loosen the hook and loop strap binding the cables to the cable management device, and then unplug the system cables and SFPs (if needed) from the controller module, keeping track of where the cables were connected.

Leave the cables in the cable management device so that when you reinstall the cable management device, the cables are organized.

4. Remove the cable management device from the controller module and set it aside.
5. Press down on both of the locking latches, and then rotate both latches downward at the same time.

The controller module moves slightly out of the chassis.

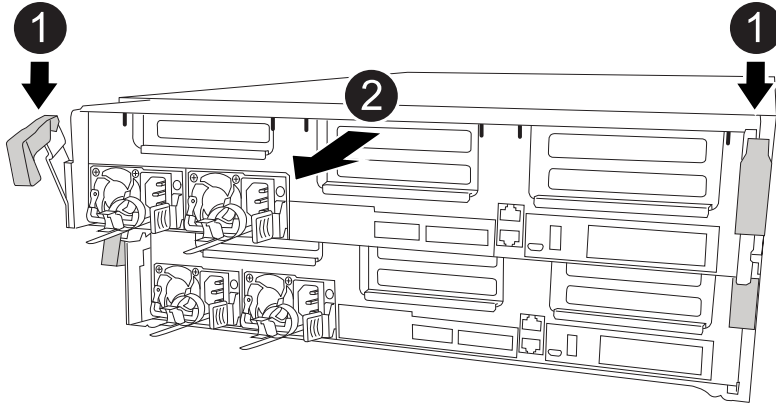

1	Locking latches
2	Controller moves slightly out of chassis

6. Slide the controller module out of the chassis.

Make sure that you support the bottom of the controller module as you slide it out of the chassis.

7. Place the controller module on a stable, flat surface.

### Step 3: Replace a PCIe card

To replace a PCIe card, you must locate the failed PCIe card, remove the riser that contains the card from the controller module, replace the card, and then reinstall the PCIe riser in the controller module.

You can use the following animation, illustration, or the written steps to replace a PCIe card.

[Animation - Replace a PCIe card](#)

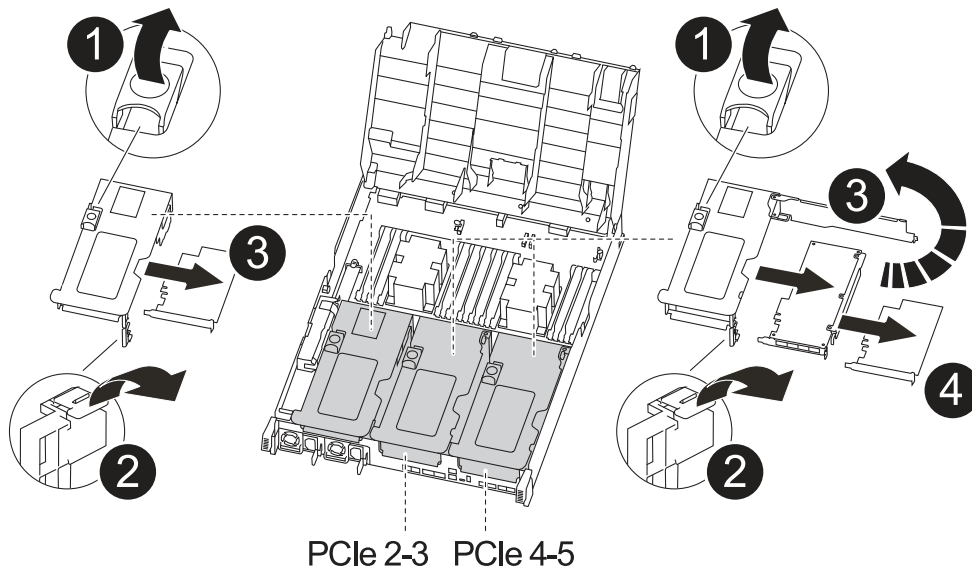

<b>1</b>	Riser locking latch
<b>2</b>	PCI card locking latch
<b>3</b>	PCI locking plate
<b>4</b>	PCI card

1. Remove the riser containing the card to be replaced:

- a. Open the air duct by pressing the locking tabs on the sides of the air duct, slide it toward the back of the controller module, and then rotate it to its completely open position.
- b. Remove any SFP or QSFP modules that might be in the PCIe cards.
- c. Rotate the riser locking latch on the left side of the riser up and toward air duct.

The riser raises up slightly from the controller module.

- d. Lift the riser up straight up and set it aside on a stable flat surface,

2. Remove the PCIe card from the riser:

- a. Turn the riser so that you can access the PCIe card.
- b. Press the locking bracket on the side of the PCIe riser, and then rotate it to the open position.
- c. For risers 2 and 3 only, swing the side panel up.
- d. Remove the PCIe card from the riser by gently pushing up on the bracket and lift the card straight out of the socket.

3. Install the replacement PCIe card in the riser by aligning the card with the socket, press the card into the socket and then close the side panel on the riser, if present.

Be sure that you properly align the card in the slot and exert even pressure on the card when seating it in the socket. The PCIe card must be fully and evenly seated in the slot.



If you are installing a card in the bottom slot and cannot see the card socket well, remove the top card so that you can see the card socket, install the card, and then reinstall the card you removed from the top slot.

4. Reinstall the riser:

- a. Align the riser with the pins to the side of the riser socket, lower the riser down on the pins.
- b. Push the riser squarely into the socket on the motherboard.
- c. Rotate the latch down flush with the sheet metal on the riser.

**Step 4: Replace the mezzanine card**

The mezzanine card is located under riser number 3 (slots 4 and 5). You must remove that riser to access the mezzanine card, replace the mezzanine card, and then reinstall riser number 3. See the FRU map on the controller module for more information.

You can use the following animation, illustration, or the written steps to replace the mezzanine card.

[Animation - Replace the mezzanine card](#)

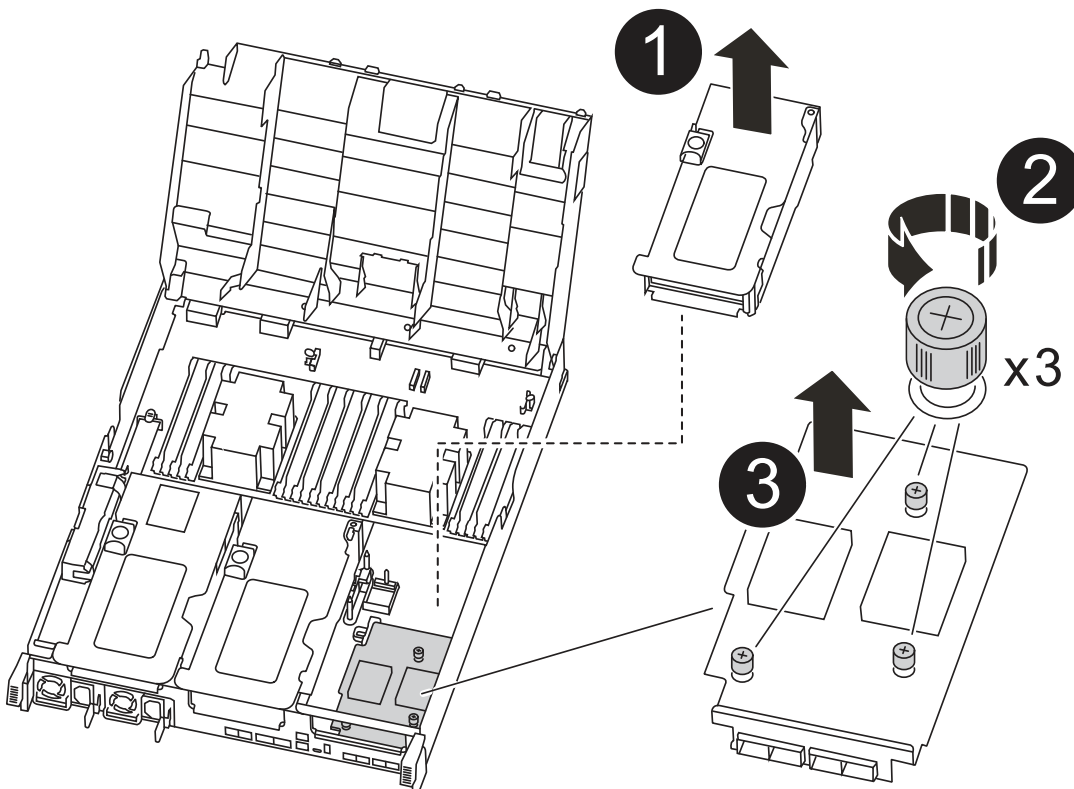

<b>1</b>	PCI riser
<b>2</b>	Riser thumbscrew



1. Remove riser number 3 (slots 4 and 5):
  - a. Open the air duct by pressing the locking tabs on the sides of the air duct, slide it toward the back of the controller module, and then rotate it to its completely open position.
  - b. Remove any SFP or QSFP modules that might be in the PCIe cards.
  - c. Rotate the riser locking latch on the left side of the riser up and toward air duct.

The riser raises up slightly from the controller module.
  - d. Lift the riser up, and then set it aside on a stable, flat surface.
2. Replace the mezzanine card:
  - a. Remove any QSFP or SFP modules from the card.
  - b. Loosen the thumbscrews on the mezzanine card, and gently lift the card directly out of the socket and set it aside.
  - c. Align the replacement mezzanine card over the socket and the guide pins and gently push the card into the socket.
  - d. Tighten the thumbscrews on the mezzanine card.
3. Reinstall the riser:
  - a. Align the riser with the pins to the side of the riser socket, lower the riser down on the pins.
  - b. Push the riser squarely into the socket on the motherboard.
  - c. Rotate the latch down flush with the sheet metal on the riser.

### Step 5: Install the controller module

After you have replaced the component in the controller module, you must reinstall the controller module into the chassis, and then boot it to Maintenance mode.

1. If you have not already done so, close the air duct.
2. Align the end of the controller module with the opening in the chassis, and then gently push the controller module halfway into the system.



Do not completely insert the controller module in the chassis until instructed to do so.

3. Recable the system, as needed.

If you removed the media converters (QSFPs or SFPs), remember to reinstall them if you are using fiber optic cables.

4. Complete the installation of the controller module:
  - a. Plug the power cord into the power supply, reinstall the power cable locking collar, and then connect the power supply to the power source.
  - b. Using the locking latches, firmly push the controller module into the chassis until it meets the midplane and is fully seated.

The locking latches rise when the controller module is fully seated.



Do not use excessive force when sliding the controller module into the chassis to avoid damaging the connectors.

The controller module begins to boot as soon as it is fully seated in the chassis. Be prepared to interrupt the boot process.

- c. Fully seat the controller module in the chassis by rotating the locking latches upward, tilting them so that they clear the locking pins, gently push the controller all the way in, and then lower the locking latches into the locked position.
- d. If you have not already done so, reinstall the cable management device.
- e. Interrupt the normal boot process and boot to LOADER by pressing `Ctrl-C`.



If your system stops at the boot menu, select the option to boot to LOADER.

- f. At the LOADER prompt, enter `bye` to reinitialize the PCIe cards and other components and let the controller reboot.
5. Return the controller to normal operation by giving back its storage: `storage failover giveback -ofnode impaired_node_name`
  6. If automatic giveback was disabled, reenable it: `storage failover modify -node local -auto -giveback true`

## Step 6: Restore the controller module to operation

To restore the controller, you must recable the system, give back the controller module, and then reenable automatic giveback.

1. Recable the system, as needed.

If you removed the media converters (QSFPs or SFPs), remember to reinstall them if you are using fiber optic cables.

2. Return the controller to normal operation by giving back its storage: `storage failover giveback -ofnode impaired_node_name`
3. If automatic giveback was disabled, reenable it: `storage failover modify -node local -auto -giveback true`

## Step 7: Switch back aggregates in a two-node MetroCluster configuration

After you have completed the FRU replacement in a two-node MetroCluster configuration, you can perform the MetroCluster switchback operation. This returns the configuration to its normal operating state, with the sync-source storage virtual machines (SVMs) on the formerly impaired site now active and serving data from the local disk pools.

This task only applies to two-node MetroCluster configurations.

### Steps

1. Verify that all nodes are in the `enabled state`: `metrocluster node show`

```

cluster_B::> metrocluster node show

DR                               Configuration  DR
Group Cluster Node              State          Mirroring Mode
-----
1      cluster_A
      controller_A_1 configured    enabled    heal roots
completed
      cluster_B
      controller_B_1 configured    enabled    waiting for
switchback recovery
2 entries were displayed.

```

2. Verify that resynchronization is complete on all SVMs: `metrocluster vserver show`
3. Verify that any automatic LIF migrations being performed by the healing operations were completed successfully: `metrocluster check lif show`
4. Perform the switchback by using the `metrocluster switchback` command from any node in the surviving cluster.
5. Verify that the switchback operation has completed: `metrocluster show`

The switchback operation is still running when a cluster is in the `waiting-for-switchback` state:

```

cluster_B::> metrocluster show
Cluster              Configuration State      Mode
-----
Local: cluster_B configured    switchover
Remote: cluster_A configured    waiting-for-switchback

```

The switchback operation is complete when the clusters are in the `normal` state.:

```

cluster_B::> metrocluster show
Cluster              Configuration State      Mode
-----
Local: cluster_B configured    normal
Remote: cluster_A configured    normal

```

If a switchback is taking a long time to finish, you can check on the status of in-progress baselines by using the `metrocluster config-replication resync-status show` command.

6. Reestablish any SnapMirror or SnapVault configurations.

## Step 8: Return the failed part to NetApp

Return the failed part to NetApp, as described in the RMA instructions shipped with the kit. See the [Part Return and Replacements](#) page for further information.

### Replacing a power supply - ASA C400

Replacing a power supply (PSU) involves disconnecting the target PSU from the power source, unplugging the power cable, removing the old PSU and installing the replacement PSU, and then reconnecting the replacement PSU to the power source.

- The power supplies are redundant and hot-swappable.
- This procedure is written for replacing one power supply at a time.



It is a best practice to replace the power supply within two minutes of removing it from the chassis. The system continues to function, but ONTAP sends messages to the console about the degraded power supply until the power supply is replaced.



Do not mix PSUs with different efficiency ratings. Always replace like for like.

You can use the following illustration with the written steps to replace the power supply.

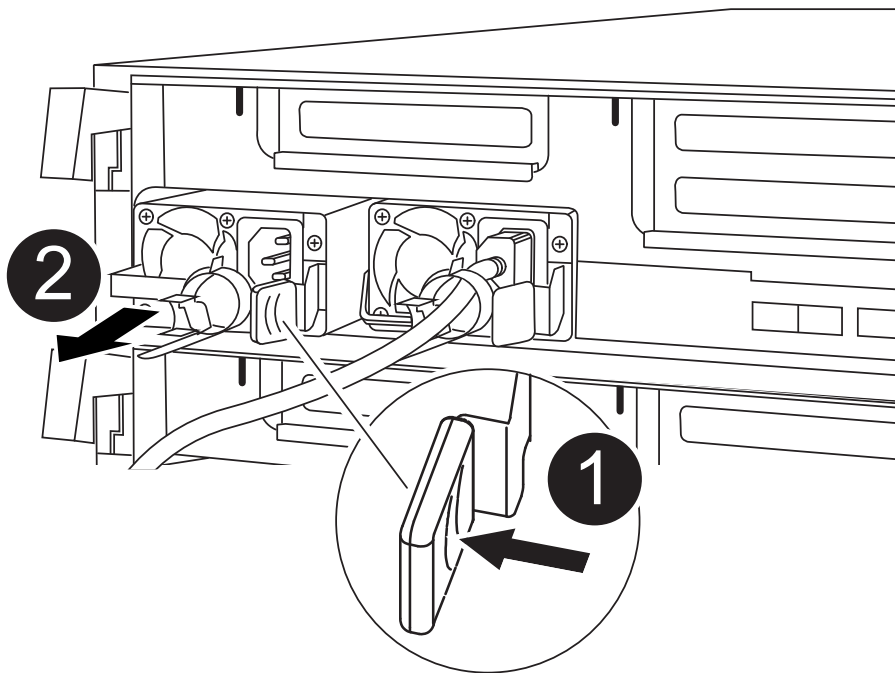

<b>1</b>	PSU locking tab
<b>2</b>	Power cable retainer

1. If you are not already grounded, properly ground yourself.

2. Identify the power supply you want to replace, based on console error messages or through the LEDs on the power supplies.
3. Disconnect the power supply:
  - a. Open the power cable retainer, and then unplug the power cable from the power supply.
  - b. Unplug the power cable from the power source.
4. Remove the power supply:
  - a. Rotate the cam handle so that it can be used to pull the power supply out of the chassis.
  - b. Press the blue locking tab to release the power supply from the chassis.
  - c. Using both hands, pull the power supply out of the chassis, and then set it aside.
5. Using both hands, support and align the edges of the power supply with the opening in the controller module, and then gently push the power supply into the controller module until the locking tab clicks into place.

The power supplies will only properly engage with the internal connector and lock in place one way.



To avoid damaging the internal connector, do not use excessive force when sliding the power supply into the system.

6. Rotate the cam handle so that it is flush against the power supply.
7. Reconnect the power supply cabling:
  - a. Reconnect the power cable to the power supply and the power source.
  - b. Secure the power cable to the power supply using the power cable retainer.Once power is restored to the power supply, the status LED should be green.
8. Return the failed part to NetApp, as described in the RMA instructions shipped with the kit. See the [Part Return and Replacements](#) page for further information.

#### Replace the real-time clock battery - ASA C400

You replace the real-time clock (RTC) battery in the controller module so that your system's services and applications that depend on accurate time synchronization continue to function.

- You can use this procedure with all versions of ONTAP supported by your system
- All other components in the system must be functioning properly; if not, you must contact technical support.

#### Step 1: Shut down the impaired controller

You can shut down or take over the impaired controller using different procedures, depending on the storage system hardware configuration.

### Option 1: Most configurations

To shut down the impaired controller, you must determine the status of the controller and, if necessary, take over the controller so that the healthy controller continues to serve data from the impaired controller storage.

#### About this task

- If you have a SAN system, you must have checked event messages (`cluster kernel-service show`) for the impaired controller SCSI blade. The `cluster kernel-service show` command (from `priv advanced` mode) displays the node name, quorum status of that node, availability status of that node, and operational status of that node.

Each SCSI-blade process should be in quorum with the other nodes in the cluster. Any issues must be resolved before you proceed with the replacement.

- If you have a cluster with more than two nodes, it must be in quorum. If the cluster is not in quorum or a healthy controller shows false for eligibility and health, you must correct the issue before shutting down the impaired controller; see [Synchronize a node with the cluster](#).

#### Steps

1. If AutoSupport is enabled, suppress automatic case creation by invoking an AutoSupport message:

```
system node autosupport invoke -node * -type all -message MAINT=<# of hours>h
```

The following AutoSupport message suppresses automatic case creation for two hours: `cluster1:>`

```
system node autosupport invoke -node * -type all -message MAINT=2h
```

2. Disable automatic giveback from the console of the healthy controller: `storage failover modify -node local -auto-giveback false`



When you see *Do you want to disable auto-giveback?*, enter *y*.

3. Take the impaired controller to the LOADER prompt:

If the impaired controller is displaying...	Then...
The LOADER prompt	Go to the next step.
Waiting for giveback...	Press Ctrl-C, and then respond <i>y</i> when prompted.
System prompt or password prompt	Take over or halt the impaired controller from the healthy controller: <code>storage failover takeover -ofnode <i>impaired_node_name</i></code>  When the impaired controller shows <i>Waiting for giveback...</i> , press Ctrl-C, and then respond <i>y</i> .

### Option 2: Controller is in a two-node MetroCluster

To shut down the impaired controller, you must determine the status of the controller and, if necessary,

switch over the controller so that the healthy controller continues to serve data from the impaired controller storage.

### About this task

- You must leave the power supplies turned on at the end of this procedure to provide power to the healthy controller.

### Steps

1. Check the MetroCluster status to determine whether the impaired controller has automatically switched over to the healthy controller: `metrocluster show`
2. Depending on whether an automatic switchover has occurred, proceed according to the following table:

If the impaired controller...	Then...
Has automatically switched over	Proceed to the next step.
Has not automatically switched over	Perform a planned switchover operation from the healthy controller: <code>metrocluster switchover</code>
Has not automatically switched over, you attempted switchover with the <code>metrocluster switchover</code> command, and the switchover was vetoed	Review the veto messages and, if possible, resolve the issue and try again. If you are unable to resolve the issue, contact technical support.

3. Resynchronize the data aggregates by running the `metrocluster heal -phase aggregates` command from the surviving cluster.

```
controller_A_1::> metrocluster heal -phase aggregates
[Job 130] Job succeeded: Heal Aggregates is successful.
```

If the healing is vetoed, you have the option of reissuing the `metrocluster heal` command with the `-override-vetoes` parameter. If you use this optional parameter, the system overrides any soft vetoes that prevent the healing operation.

4. Verify that the operation has been completed by using the `metrocluster operation show` command.

```
controller_A_1::> metrocluster operation show
  Operation: heal-aggregates
  State: successful
Start Time: 7/25/2016 18:45:55
End Time: 7/25/2016 18:45:56
Errors: -
```

5. Check the state of the aggregates by using the `storage aggregate show` command.

```

controller_A_1::> storage aggregate show
Aggregate      Size Available Used% State   #Vols  Nodes
RAID Status
-----
...
aggr_b2       227.1GB   227.1GB   0% online    0 mcc1-a2
raid_dp, mirrored, normal...

```

6. Heal the root aggregates by using the `metrocluster heal -phase root-aggregates` command.

```

mcc1A::> metrocluster heal -phase root-aggregates
[Job 137] Job succeeded: Heal Root Aggregates is successful

```

If the healing is vetoed, you have the option of reissuing the `metrocluster heal` command with the `-override-vetoes` parameter. If you use this optional parameter, the system overrides any soft vetoes that prevent the healing operation.

7. Verify that the heal operation is complete by using the `metrocluster operation show` command on the destination cluster:

```

mcc1A::> metrocluster operation show
Operation: heal-root-aggregates
State: successful
Start Time: 7/29/2016 20:54:41
End Time: 7/29/2016 20:54:42
Errors: -

```

8. On the impaired controller module, disconnect the power supplies.

## Step 2: Remove the controller module

To access components inside the controller module, you must remove the controller module from the chassis.

1. If you are not already grounded, properly ground yourself.
2. Release the power cable retainers, and then unplug the cables from the power supplies.
3. Loosen the hook and loop strap binding the cables to the cable management device, and then unplug the system cables and SFPs (if needed) from the controller module, keeping track of where the cables were connected.

Leave the cables in the cable management device so that when you reinstall the cable management device, the cables are organized.

4. Remove the cable management device from the controller module and set it aside.



5. Press down on both of the locking latches, and then rotate both latches downward at the same time.

The controller module moves slightly out of the chassis.

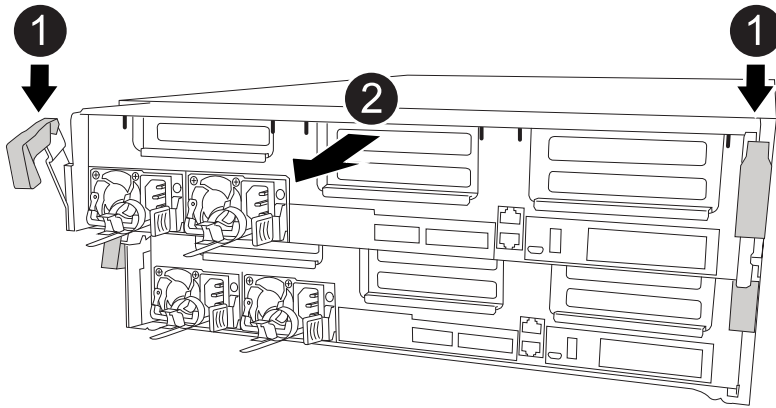

<b>1</b>	Locking latches
<b>2</b>	Controller moves slightly out of chassis

6. Slide the controller module out of the chassis.

Make sure that you support the bottom of the controller module as you slide it out of the chassis.

7. Place the controller module on a stable, flat surface.

### Step 3: Replace the RTC battery

You need to locate the RTC battery inside the controller module, and then follow the specific sequence of steps. See the FRU map inside the controller module for the location of the RTC battery.

You can use the following animation, illustration, or the written steps to replace the RTC battery.

#### Animation- Replace the RTC battery

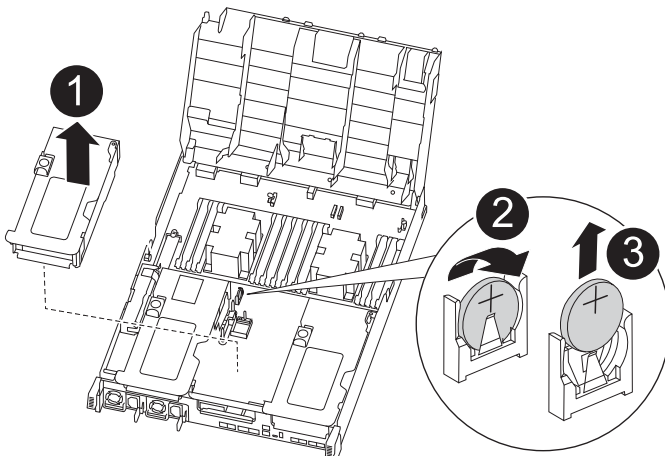

<b>1</b>	Middle riser
<b>2</b>	Remove RTC battery
<b>3</b>	Seat RTC battery

1. If you are not already grounded, properly ground yourself.
2. Open the air duct:
  - a. Press the locking tabs on the sides of the air duct in toward the middle of the controller module.
  - b. Slide the air duct toward the back of the controller module, and then rotate it upward to its completely open position.
3. Locate, remove, and then replace the RTC battery:
  - a. Using the FRU map, locate the RTC battery on the controller module.
  - b. Gently push the battery away from the holder, rotate it away from the holder, and then lift it out of the holder.



Note the polarity of the battery as you remove it from the holder. The battery is marked with a plus sign and must be positioned in the holder correctly. A plus sign near the holder tells you how the battery should be positioned.

- c. Remove the replacement battery from the antistatic shipping bag.
  - d. Note the polarity of the RTC battery, and then insert it into the holder by tilting the battery at an angle and pushing down.
4. Visually inspect the battery to make sure that it is completely installed into the holder and that the polarity is correct.
5. Close the air duct.

#### **Step 4: Reinstall the controller module and setting time/date after RTC battery replacement**

After you replace a component within the controller module, you must reinstall the controller module in the system chassis, reset the time and date on the controller, and then boot it.

1. If you have not already done so, close the air duct or controller module cover.
2. Align the end of the controller module with the opening in the chassis, and then gently push the controller module halfway into the system.

Do not completely insert the controller module in the chassis until instructed to do so.

3. Recable the system, as needed.

If you removed the media converters (QSFPs or SFPs), remember to reinstall them if you are using fiber optic cables.

4. If the power supplies were unplugged, plug them back in and reinstall the power cable retainers.
5. Complete the installation of the controller module:

- a. Using the locking latches, firmly push the controller module into the chassis until it meets the midplane and is fully seated.

The locking latches rise when the controller module is fully seated.



Do not use excessive force when sliding the controller module into the chassis to avoid damaging the connectors.

The controller module begins to boot as soon as it is fully seated in the chassis. Be prepared to interrupt the boot process.

- b. Fully seat the controller module in the chassis by rotating the locking latches upward, tilting them so that they clear the locking pins, gently push the controller all the way in, and then lower the locking latches into the locked position.
- c. If you have not already done so, reinstall the cable management device.
- d. Interrupt the normal boot process and boot to LOADER by pressing `Ctrl-C`.



If your system stops at the boot menu, select the option to boot to LOADER.

6. Reset the time and date on the controller:

- a. Check the date and time on the healthy controller with the `show date` command.
- b. At the LOADER prompt on the target controller, check the time and date.
- c. If necessary, modify the date with the `set date mm/dd/yyyy` command.
- d. If necessary, set the time, in GMT, using the `set time hh:mm:ss` command.
- e. Confirm the date and time on the target controller.

7. At the LOADER prompt, enter `bye` to reinitialize the PCIe cards and other components and let the controller reboot.

8. Return the controller to normal operation by giving back its storage: `storage failover giveback -ofnode impaired_node_name`

9. If automatic giveback was disabled, reenable it: `storage failover modify -node local -auto-giveback true`

### Step 5: Switch back aggregates in a two-node MetroCluster configuration

After you have completed the FRU replacement in a two-node MetroCluster configuration, you can perform the MetroCluster switchback operation. This returns the configuration to its normal operating state, with the sync-source storage virtual machines (SVMs) on the formerly impaired site now active and serving data from the local disk pools.

This task only applies to two-node MetroCluster configurations.

#### Steps

1. Verify that all nodes are in the `enabled state`: `metrocluster node show`

```

cluster_B::> metrocluster node show

DR
Group Cluster Node          Configuration  DR
-----
-----
1      cluster_A
      controller_A_1 configured    enabled    heal roots
completed
      cluster_B
      controller_B_1 configured    enabled    waiting for
switchback recovery
2 entries were displayed.

```

2. Verify that resynchronization is complete on all SVMs: `metrocluster vserver show`
3. Verify that any automatic LIF migrations being performed by the healing operations were completed successfully: `metrocluster check lif show`
4. Perform the switchback by using the `metrocluster switchback` command from any node in the surviving cluster.
5. Verify that the switchback operation has completed: `metrocluster show`

The switchback operation is still running when a cluster is in the `waiting-for-switchback` state:

```

cluster_B::> metrocluster show
Cluster          Configuration State      Mode
-----
Local: cluster_B configured    switchover
Remote: cluster_A configured    waiting-for-switchback

```

The switchback operation is complete when the clusters are in the `normal` state.:

```

cluster_B::> metrocluster show
Cluster          Configuration State      Mode
-----
Local: cluster_B configured    normal
Remote: cluster_A configured    normal

```

If a switchback is taking a long time to finish, you can check on the status of in-progress baselines by using the `metrocluster config-replication resync-status show` command.

6. Reestablish any SnapMirror or SnapVault configurations.

## Step 6: Return the failed part to NetApp

Return the failed part to NetApp, as described in the RMA instructions shipped with the kit. See the [Part Return and Replacements](#) page for further information.

## ASA C800 systems

### Install and setup

**Start here: Choose your installation and setup experience**

For most configurations (including ASA configurations), you can choose from different content formats.

- [Quick steps](#)

A printable PDF of step-by-step instructions with live links to additional content.

- [Video steps](#)

Video step-by-step instructions.

- [Detailed steps](#)

Online step-by-step instructions with live links to additional content.

If your system is in a MetroCluster IP configuration, see the [Install MetroCluster IP Configuration](#) instructions.

### Quick steps - ASA C800

Quick start gives graphic instructions for a typical installation of your system from racking and cabling, through initial system bring-up.

Use the [ASA C800 Installation and Setup Instructions](#) if you are familiar with installing NetApp systems.

### Videos - ASA C800

There are two videos - one showing how to rack and cable your system and one showing an example of using the System Manager Guided Setup to perform initial system configuration.

#### Video one of two: Hardware installation and cabling

The following video shows how to install and cable your new system.

["Animation - Installation and Setup of an ASA C800](#)

#### Video two of two: Perform end-to-end software configuration

The following video shows end-to-end software configuration for systems running ONTAP 9.2 and later.

 | <https://img.youtube.com/vi/WAE0afWhj1c?/maxresdefault.jpg>

This section gives detailed step-by-step instructions for installing an ASA C800 system.

### Step 1: Prepare for installation

To install your ASA C800 system, you need to create an account and register the system. You also need to inventory the appropriate number and type of cables for your system and collect specific network information.

You need to have access to the [NetApp Hardware Universe](#) (HWU) for information about site requirements as well as additional information on your configured system. You might also want to have access to the [Release Notes for your version of ONTAP](#) for more information about this system.

#### What you need

You need to provide the following at your site:





- Rack space for the storage system
- Phillips #2 screwdriver
- Additional networking cables to connect your system to your network switch and laptop or console with a Web browser
  1. Unpack the contents of all boxes.
  2. Record the system serial number from the controllers.



#### Steps

1. Set up your account:
  - a. Log in to your existing account or create an account.
  - b. Register ([NetApp Product Registration](#)) your system.
2. Download and install [NetApp Downloads: Config Advisor](#) on your laptop.
3. Inventory and make a note of the number and types of cables you received.

The following table identifies the types of cables you might receive. If you receive a cable not listed in the table, see the [NetApp Hardware Universe](#) to locate the cable and identify its use.

Connector type	Part number and length	Type of cable...	For...
100 GbE cable	X66211A-05 (112-00595), 0.5m		HA interconnect
	X66211A-05 (112-00595), 0.5m; X66211-1 (112-00573), 1m		Cluster interconnect network
	X66211-2 (112-00574), 2m; X66211-5 (112-00576), 5m		Storage, Data
10 GbE cable	X6566B-3-R6 (112-00300), 3m; X6566B-5-R6 (112-00301), 5m		Data
25 GbE cable	X66240A-2 (112-00598), 2m; X66240A-5 (112-00600), 5m		Data
RJ-45 (order dependent)	Not applicable		Management
Fibre Channel	X66250-2 (112-00342) 2m; X66250-5 (112-00344) 5m; X66250-15 (112-00346) 15m; X66250-30 (112-00347) 30m		
Micro-USB console cable	Not applicable		Console connection during software setup
Power cables	Not applicable		Powering up the system

- Download and complete the [Cluster Configuration Worksheet](#).

## Step 2: Install the hardware

You need to install your system in a 4-post rack or NetApp system cabinet, as applicable.

### Steps

- Install the rail kits, as needed.

#### [Installing SuperRail into a four-post rack](#)

- Install and secure your system using the instructions included with the rail kit.



You need to be aware of the safety concerns associated with the weight of the system.



3. Attach cable management devices (as shown).

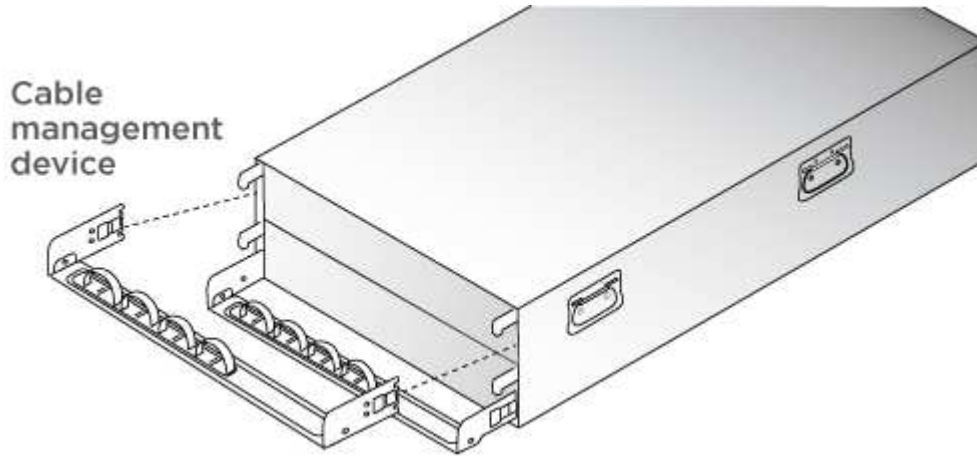

4. Place the bezel on the front of the system.

### Step 3: Cable controllers

There is required cabling for your platform's cluster using the two-node switchless cluster method or the cluster interconnect network method. There is optional cabling to the Fibre Channel or iSCSI host networks or direct-attached storage. This cabling is not exclusive; you can have cable to a host network and storage.

#### Required cabling: Cable controllers to a cluster

Cable the controllers to a cluster by using the two-node switchless cluster method or by using the cluster interconnect network.

#### Option 1: Cable a two-node switchless cluster

Management network ports on the controllers are connected to switches. The HA interconnect and cluster interconnect ports are cabled on both controllers.

#### Before you begin

Contact your network administrator for information about connecting the system to the switches.

Be sure to check the illustration arrow for the proper cable connector pull-tab orientation.

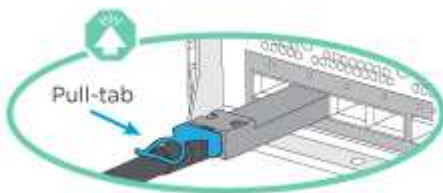

As you insert the connector, you should feel it click into place; if you do not feel it click, remove it, turn it around and try again.





## Steps

1. Use the animation or the tabulated steps to complete the cabling between the controllers and the switches:

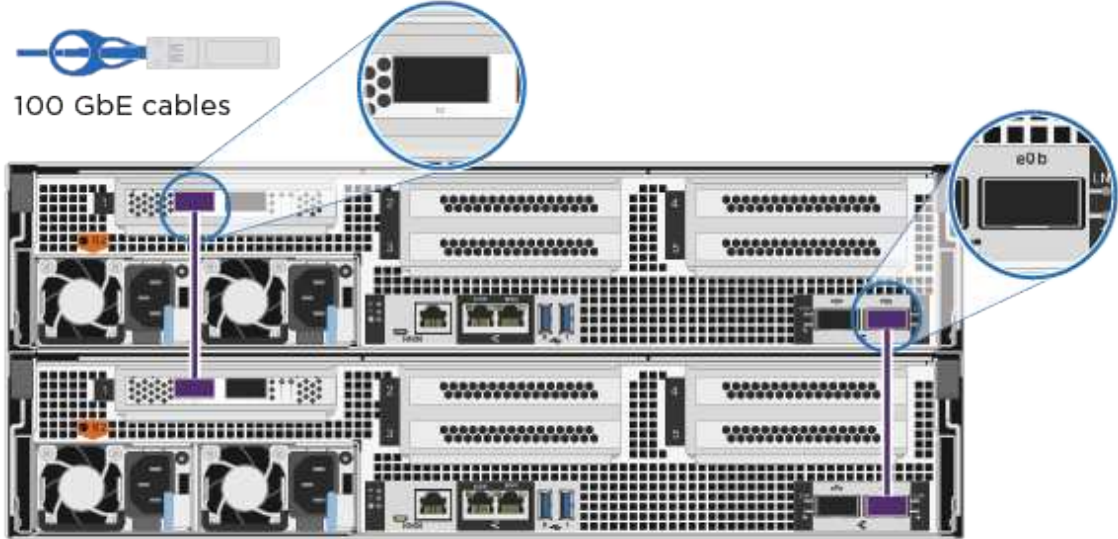
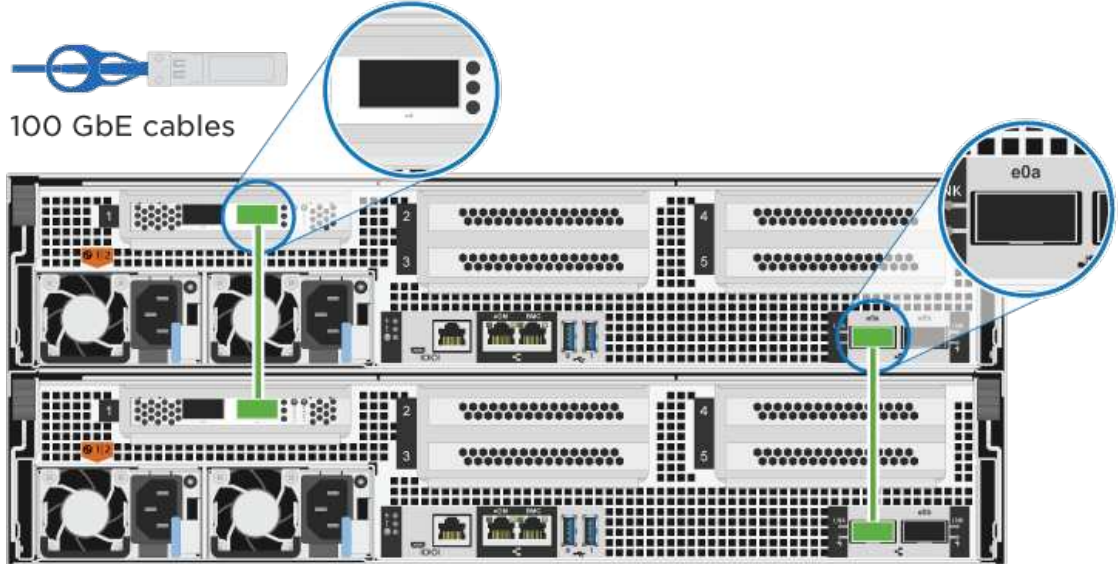
### Animation - Cable a two-node switchless cluster

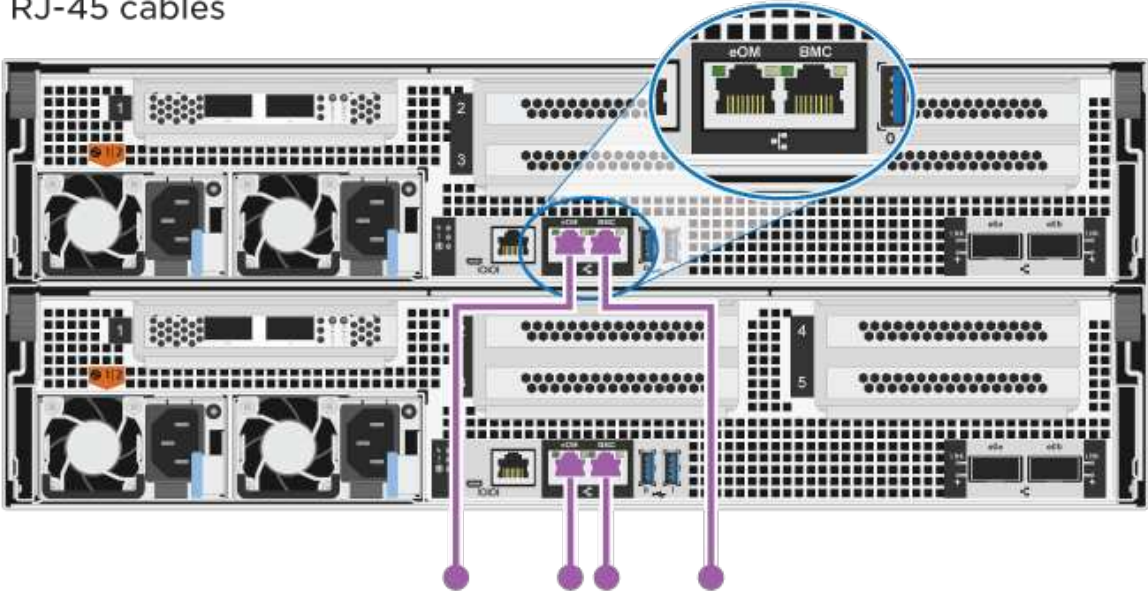
Step	Perform on each controller module
<b>1</b>	<p>Cable the HA interconnect ports:</p> <ul style="list-style-type: none"><li>• e0b to e0b</li><li>• e1b to e1b</li></ul>  <p>100 GbE cables</p>
<b>2</b>	<p>Cable the cluster interconnect ports:</p> <ul style="list-style-type: none"><li>• e0a to e0a</li><li>• e1a to e1a</li></ul>  <p>100 GbE cables</p>

<b>Step</b>	<b>Perform on each controller module</b>
<b>3</b>	<p>Cable the management ports to the management network switches</p> <p> RJ-45 cables</p> 
	DO NOT plug in the power cords at this point.

2. To perform optional cabling, see:

- [Option 1: Cable to a Fibre Channel host network](#)
- [Option 2: Cable to a 10GbE host network](#)
- [Option 3: Cable the controllers to a single drive shelf](#)
- [Option 4: Cable the controllers to two drive shelves](#)

3. To complete setting up your system, see [Step 4: Complete system setup and configuration](#).

### Option 2: Cable a switched cluster

Cluster interconnect and management network ports on the controllers are connected to switches while the HA interconnect ports are cabled on both controllers.

#### Before you begin

Contact your network administrator for information about connecting the system to the switches.

Be sure to check the illustration arrow for the proper cable connector pull-tab orientation.

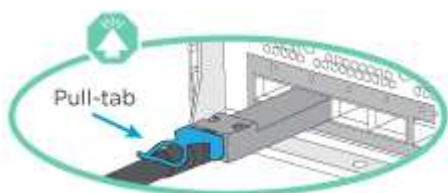



As you insert the connector, you should feel it click into place; if you do not feel it click, remove it, turn it around and try again.

## Steps

1. Use the animation or the tabulated steps to complete the cabling between the controllers and the switches:

### Animation - Cable a switched cluster

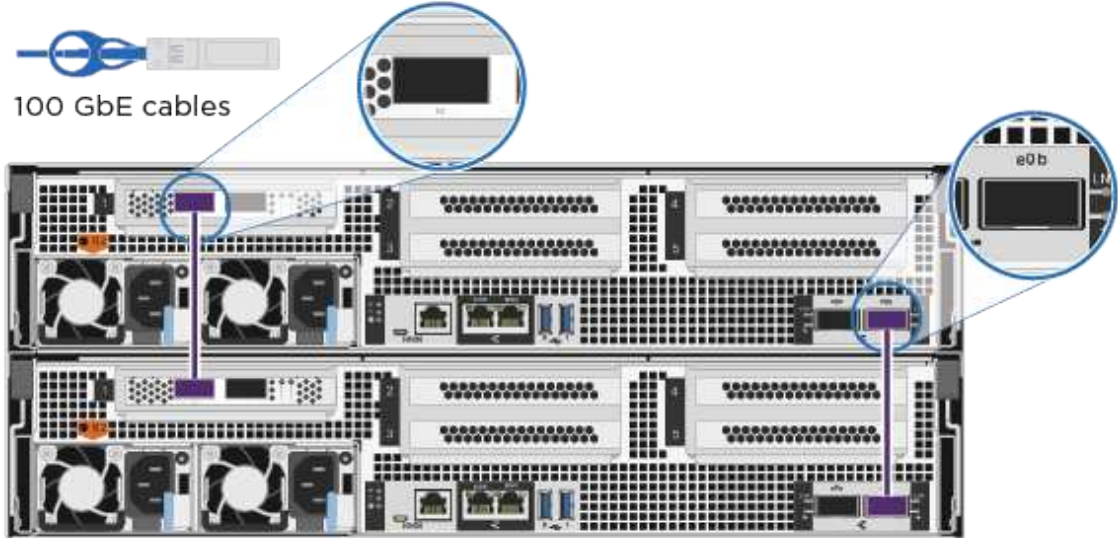
Step	Perform on each controller module
<b>1</b>	<p>Cable the HA interconnect ports:</p> <ul style="list-style-type: none"><li>• e0b to e0b</li><li>• e1b to e1b</li></ul>  <p>100 GbE cables</p>

**Step** Perform on each controller module

**2**

Cable the cluster interconnect ports to the 100 GbE cluster interconnect switches.  
e0a  
e1a

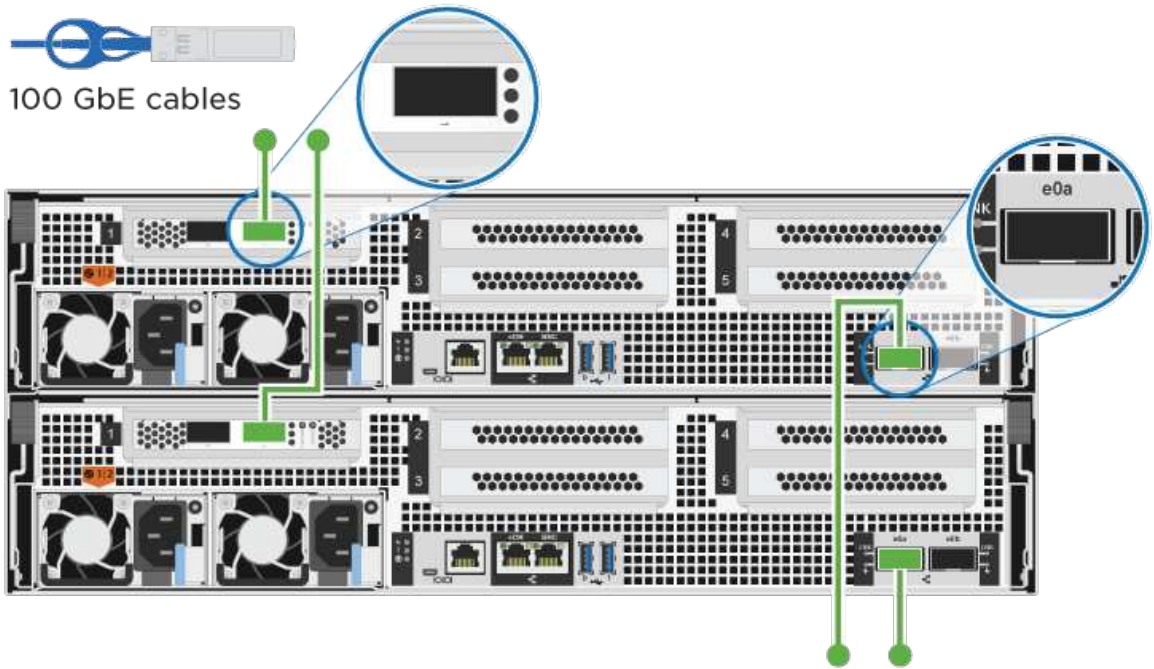

**3**

Cable the management ports to the management network switches

RJ-45 cables

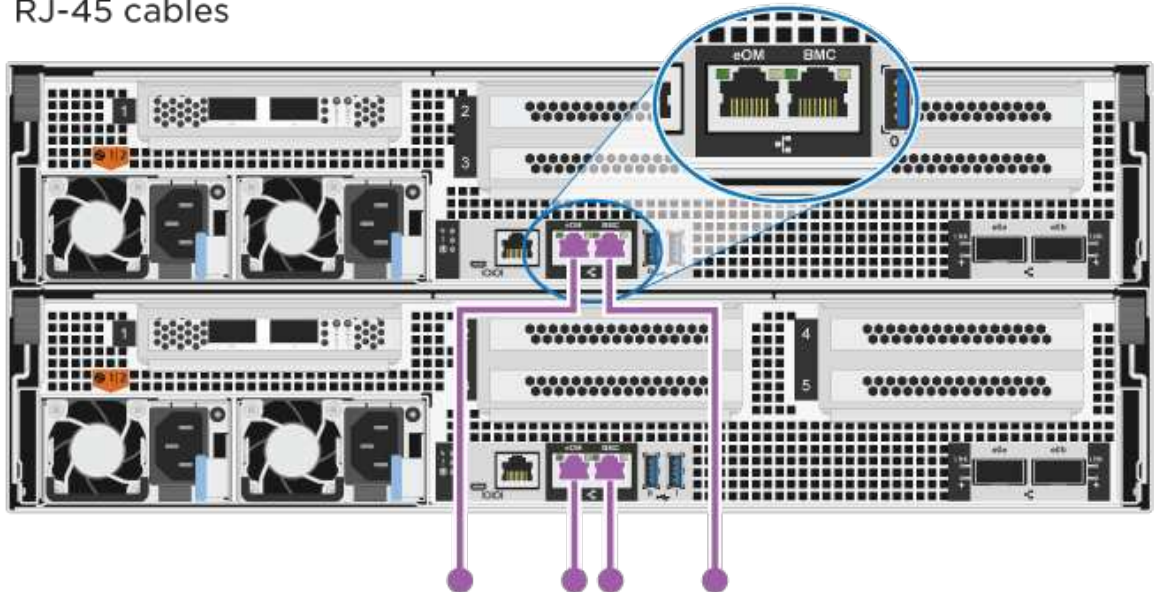

DO NOT plug in the power cords at this point.

2. To perform optional cabling, see:

- [Option 1: Cable to a Fibre Channel host network](#)
- [Option 2: Cable to a 10GbE host network](#)
- [Option 3: Cable the controllers to a single drive shelf](#)
- [Option 4: Cable the controllers to two drive shelves](#)

3. To complete setting up your system, see [Step 4: Complete system setup and configuration](#).

### Optional cabling: Cable configuration-dependent options

You have configuration-dependent optional cabling to the Fibre Channel or iSCSI host networks or direct-attached storage. This cabling is not exclusive; you can have cabling to a host network and storage.

#### Option 1: Cable to a Fibre Channel host network

Fibre Channel ports on the controllers are connected to Fibre Channel host network switches.

##### Before you begin

Contact your network administrator for information about connecting the system to the switches.

Be sure to check the illustration arrow for the proper cable connector pull-tab orientation.

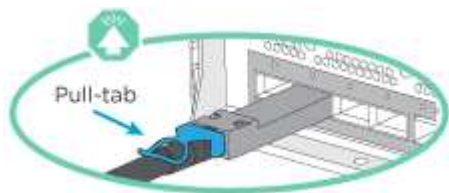

As you insert the connector, you should feel it click into place; if you do not feel it click, remove it, turn it around and try again.

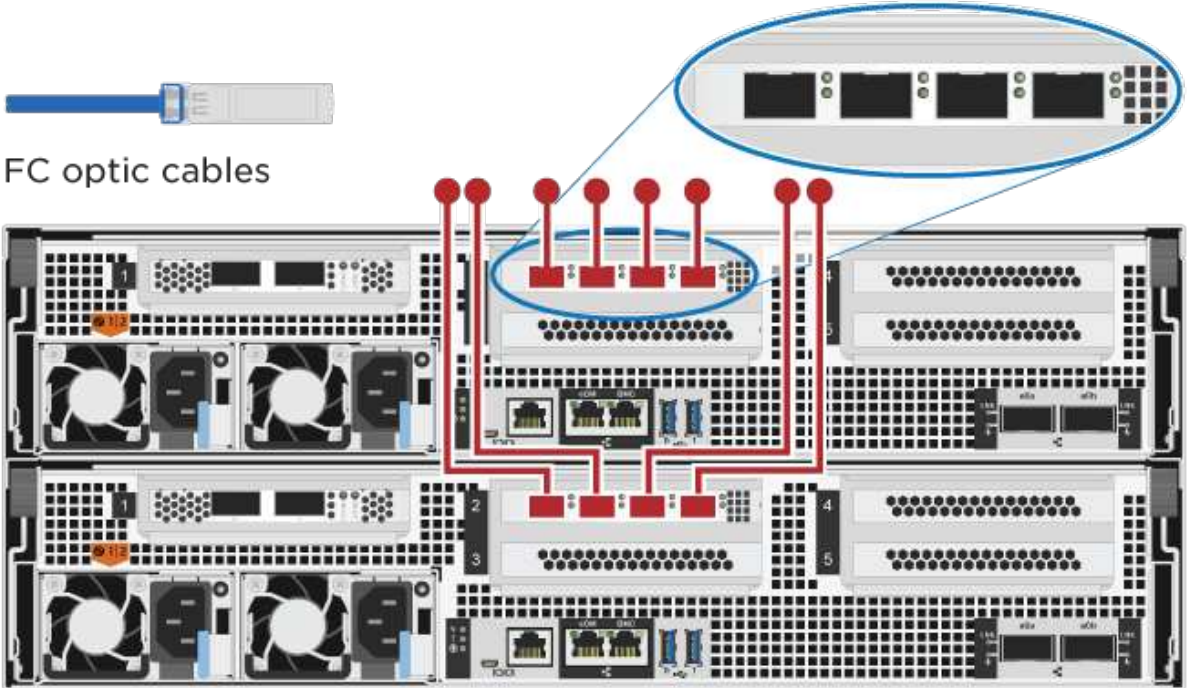
Step	Perform on each controller module
1	<p>Cable ports 2a through 2d to the FC host switches.</p>  <p>FC optic cables</p>
2	<p>To perform other optional cabling, choose from:</p> <ul style="list-style-type: none"> <li>• <a href="#">Option 3: Cable the controllers to a single drive shelf</a></li> <li>• <a href="#">Option 4: Cable the controllers to two drive shelves</a></li> </ul>
3	<p>To complete setting up your system, see <a href="#">Step 4: Complete system setup and configuration</a>.</p>

## Option 2: Cable to a 10GbE host network

10GbE ports on the controllers are connected to 10GbE host network switches.

### Before you begin

Contact your network administrator for information about connecting the system to the switches.

Be sure to check the illustration arrow for the proper cable connector pull-tab orientation.

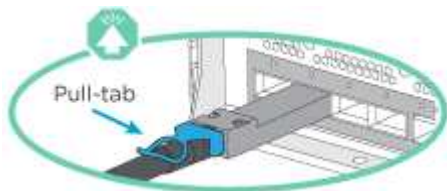

As you insert the connector, you should feel it click into place; if you do not feel it click, remove it, turn it around and try again.

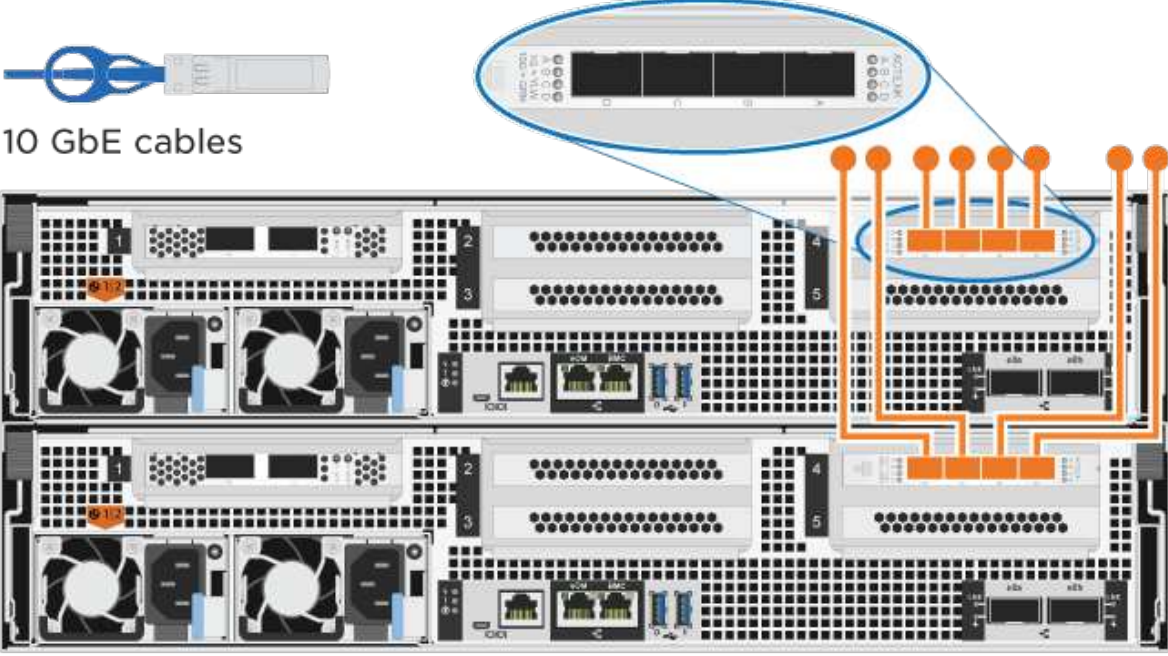
Step	Perform on each controller module
1	<p data-bbox="269 157 966 220">Cable ports e4a through e4d to the 10GbE host network switches.</p>  <p data-bbox="300 388 544 420">10 GbE cables</p>
2	<p data-bbox="269 987 852 1018">To perform other optional cabling, choose from:</p> <ul data-bbox="300 1050 966 1134" style="list-style-type: none"> <li data-bbox="300 1050 966 1081">• <a href="#">Option 3: Cable the controllers to a single drive shelf</a></li> <li data-bbox="300 1102 966 1134">• <a href="#">Option 4: Cable the controllers to two drive shelves</a></li> </ul>
3	<p data-bbox="269 1186 1388 1218">To complete setting up your system, see <a href="#">Step 4: Complete system setup and configuration</a>.</p>

### Option 3: Cable the controllers to a single drive shelf

You must cable each controller to the NSM modules on the NS224 drive shelf.

#### Before you begin

Be sure to check the illustration arrow for the proper cable connector pull-tab orientation.

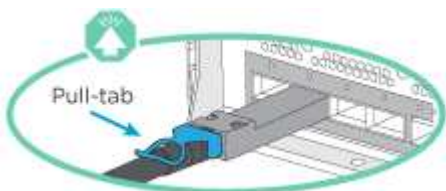

As you insert the connector, you should feel it click into place; if you do not feel it click, remove it, turn it around and try again.

Use the animation or the tabulated steps to cable your controllers to a single shelf:

Animation - Cable the controllers to a single drive shelf

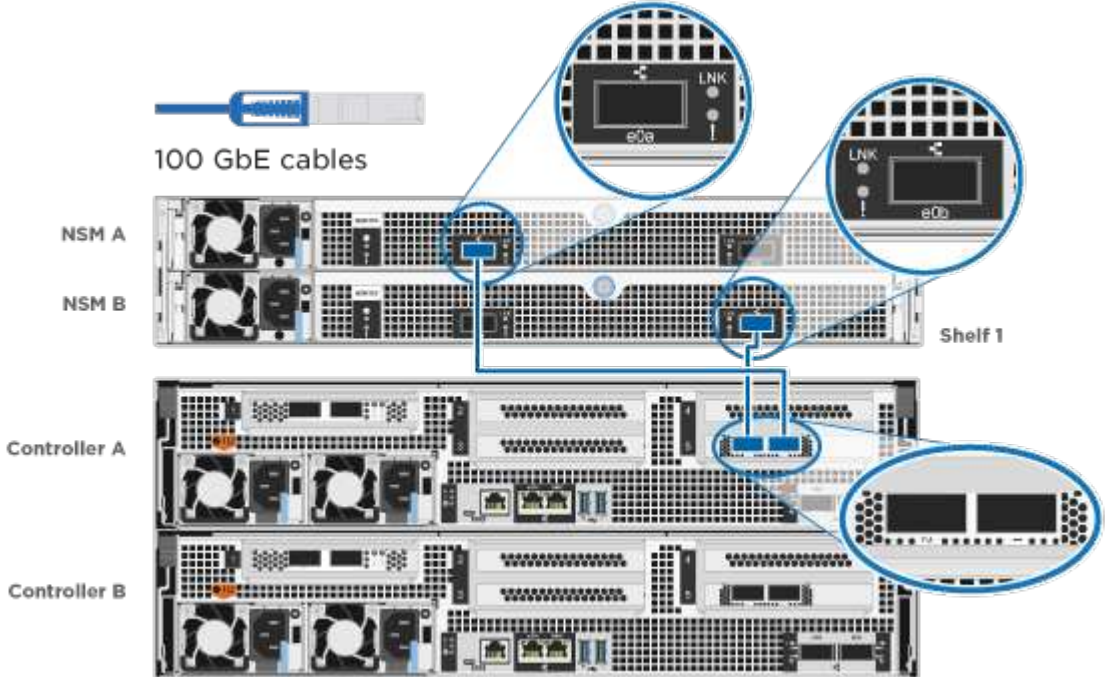
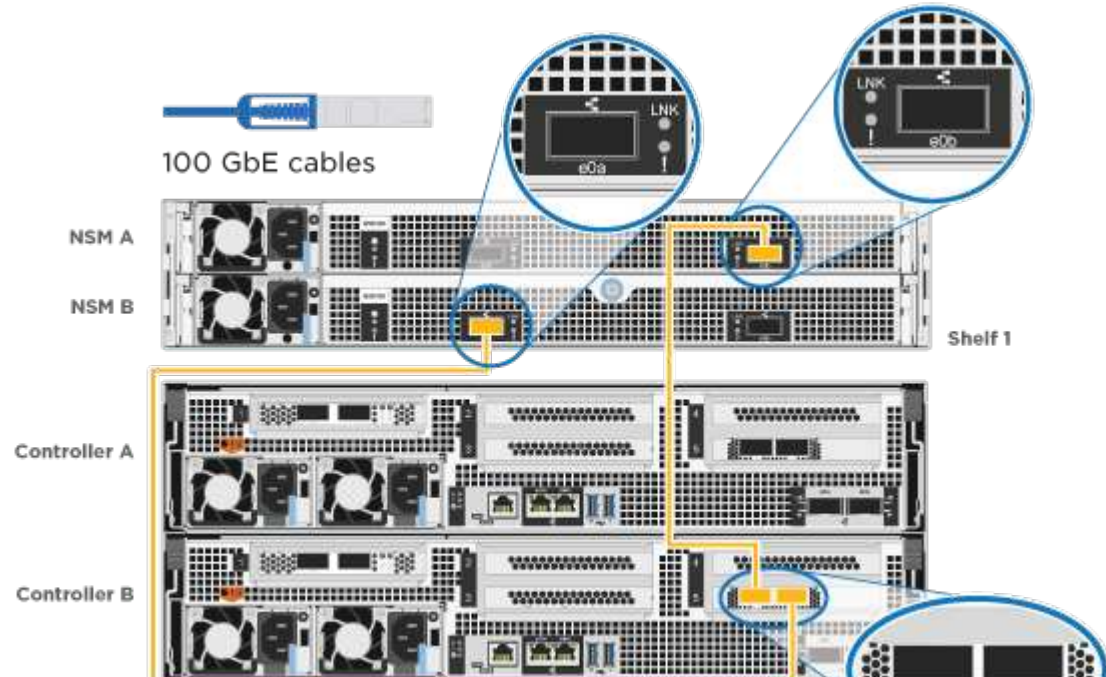
Step	Perform on each controller module
<b>1</b>	<p>Cable controller A to the shelf:</p>  <p>The diagram illustrates the connection of Controller A to Shelf 1. At the top, a blue 100 GbE cable is shown. Below it, Shelf 1 is depicted with two Network Service Modules (NSM A and NSM B). Two callouts show the LNK and e0a ports on Shelf 1. Blue lines indicate the connection of two 100 GbE cables from the LNK ports on NSM A and NSM B to the LNK ports on Controller A. A third callout shows the LNK and e0a ports on Controller A. Below Shelf 1, Controller A and Controller B are shown. A fourth callout shows the LNK and e0a ports on Controller B.</p>
<b>2</b>	<p>Cable controller B to the shelf:</p>  <p>The diagram illustrates the connection of Controller B to Shelf 1. At the top, a blue 100 GbE cable is shown. Below it, Shelf 1 is depicted with two Network Service Modules (NSM A and NSM B). Two callouts show the LNK and e0a ports on Shelf 1. Yellow lines indicate the connection of two 100 GbE cables from the LNK ports on NSM A and NSM B to the LNK ports on Controller B. A third callout shows the LNK and e0a ports on Controller B. Below Shelf 1, Controller A and Controller B are shown. A fourth callout shows the LNK and e0a ports on Controller A.</p>

To complete setting up your system, see [Step 4: Complete system setup and configuration](#).



#### Option 4: Cable the controllers to two drive shelves

You must cable each controller to the NSM modules on both NS224 drive shelves.

#### Before you begin

Be sure to check the illustration arrow for the proper cable connector pull-tab orientation.

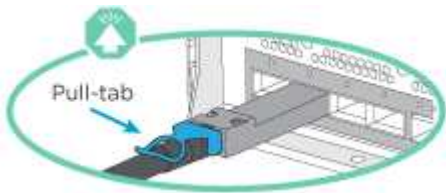

As you insert the connector, you should feel it click into place; if you do not feel it click, remove it, turn it around and try again.

Use the animation or the tabulated steps to cable your controllers to two drive shelves:

[Animation - Cable the controllers to two drive shelves](#)

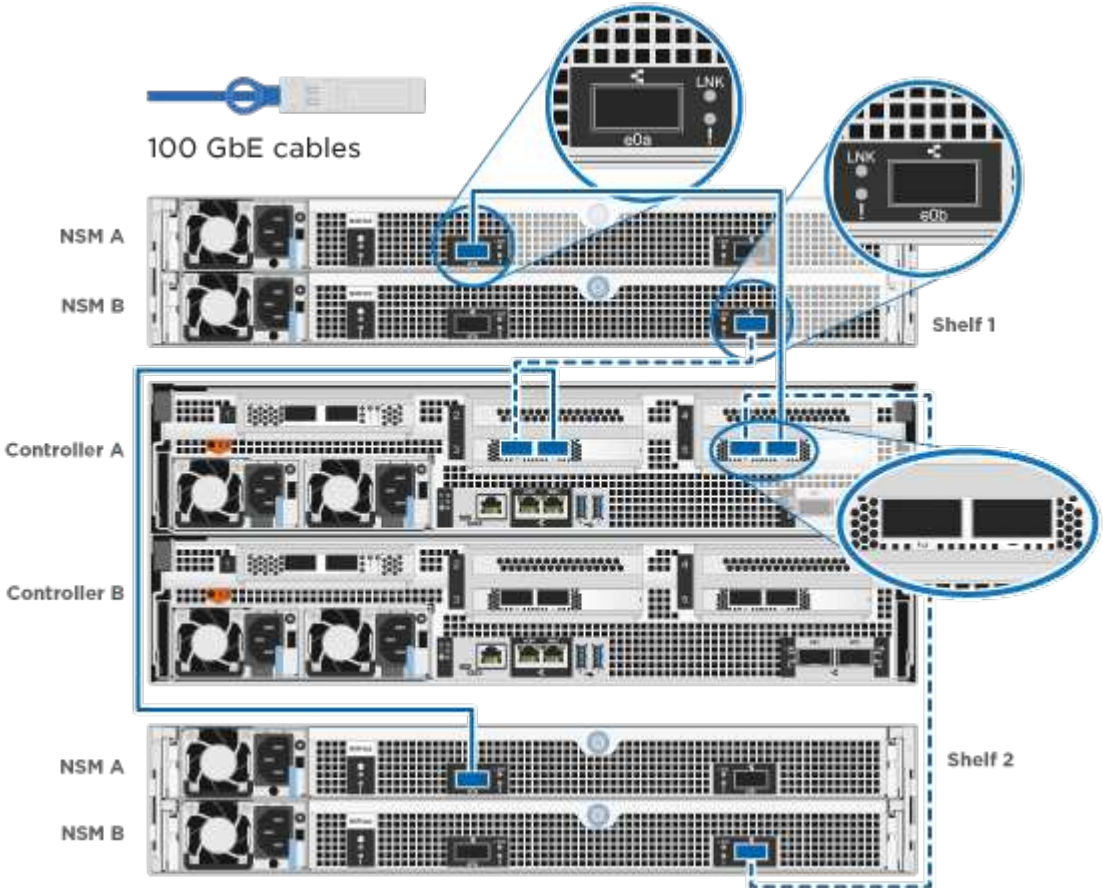
Step	Perform on each controller module
<b>1</b>	<p data-bbox="272 869 678 898">Cable controller A to the shelves:</p>  <p data-bbox="430 1033 641 1062">100 GbE cables</p> <p data-bbox="341 1129 406 1159">NSM A</p> <p data-bbox="341 1192 406 1222">NSM B</p> <p data-bbox="1209 1213 1274 1243">Shelf 1</p> <p data-bbox="284 1339 406 1369">Controller A</p> <p data-bbox="284 1486 406 1516">Controller B</p> <p data-bbox="341 1654 406 1684">NSM A</p> <p data-bbox="341 1717 406 1747">NSM B</p> <p data-bbox="1226 1654 1291 1684">Shelf 2</p>

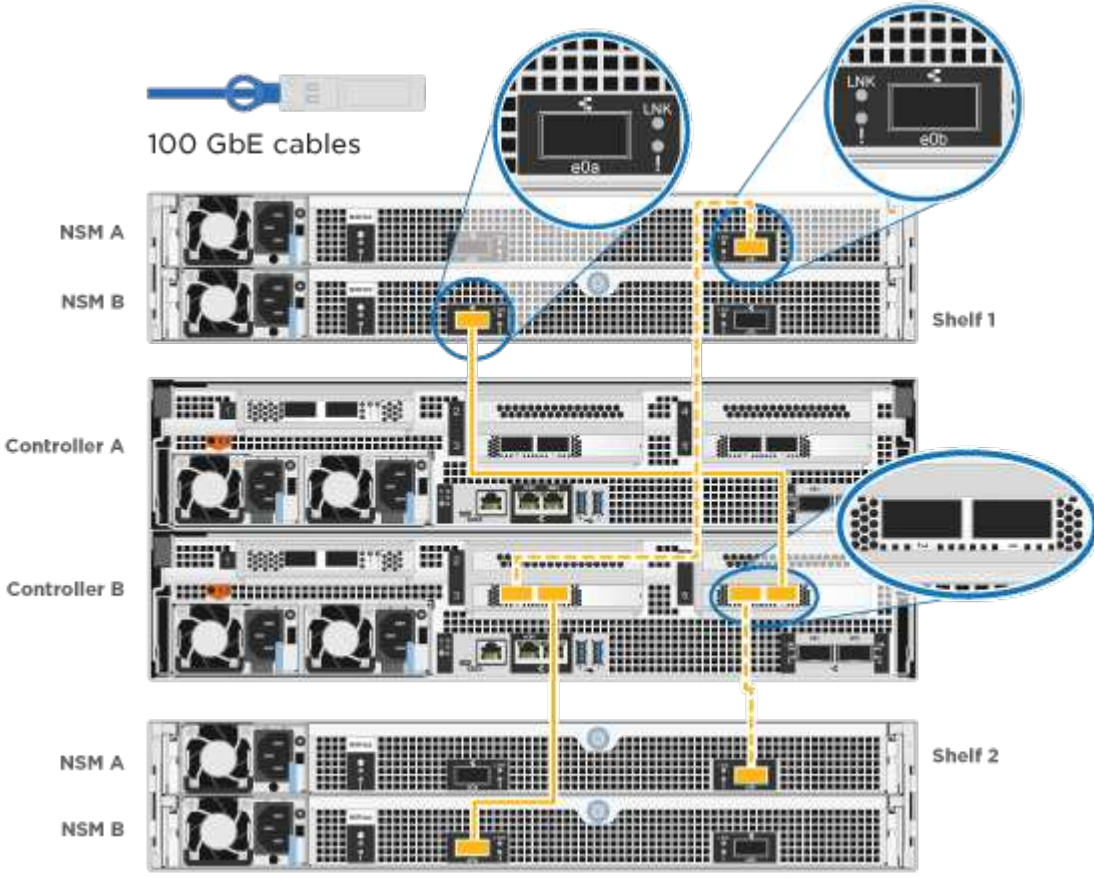
Step	Perform on each controller module
2	<p>Cable controller B to the shelves:</p>  <p>100 GbE cables</p> <p>NSM A NSM B Shelf 1</p> <p>Controller A Controller B</p> <p>NSM A NSM B Shelf 2</p>

To complete setting up your system, see [Step 4: Complete system setup and configuration](#).

#### Step 4: Complete system setup and configuration

Complete the system setup and configuration using cluster discovery with only a connection to the switch and laptop, or by connecting directly to a controller in the system and then connecting to the management switch.

##### Option 1: Complete system setup and configuration if network discovery is enabled

If you have network discovery enabled on your laptop, you can complete system setup and configuration using automatic cluster discovery.

##### Steps

1. Plug the power cords into the controller power supplies, and then connect them to power sources on different circuits.

The system begins to boot. Initial booting may take up to eight minutes.

2. Make sure that your laptop has network discovery enabled.

See your laptop's online help for more information.

3. Use the animation to connect your laptop to the Management switch:

## Animation - Connect your laptop to the Management switch

4. Select an ONTAP icon listed to discover:

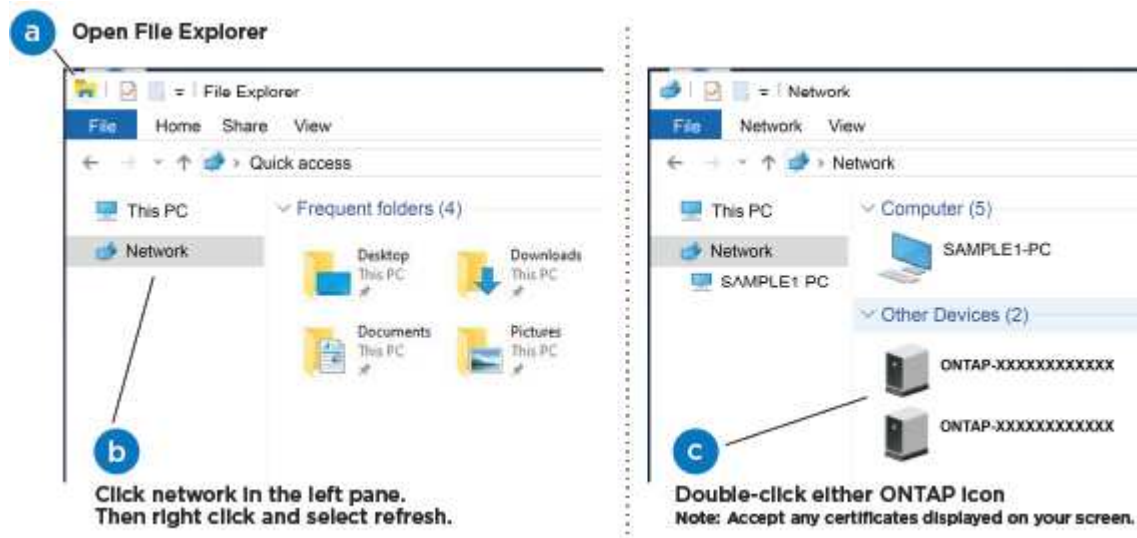

- a. Open File Explorer.
- b. Click **Network** in the left pane.
- c. Right-click and select **refresh**.
- d. Double-click either ONTAP icon and accept any certificates displayed on your screen.



XXXXX is the system serial number for the target node.

System Manager opens.

5. Use System Manager guided setup to configure your system using the data you collected in the [ONTAP Configuration Guide](#).
6. Verify the health of your system by running Config Advisor.
7. After you have completed the initial configuration, go to the [ONTAP & ONTAP System Manager Documentation Resources](#) page for information about configuring additional features in ONTAP.

### Option 2: Complete system setup and configuration if network discovery is not enabled

If network discovery is not enabled on your laptop, you must complete the configuration and setup using this task.

#### Steps

1. Cable and configure your laptop or console:
  - a. Set the console port on the laptop or console to 115,200 baud with N-8-1.



See your laptop or console's online help for how to configure the console port.

- b. Connect the console cable to the laptop or console, and connect the console port on the controller using the console cable that came with your system.

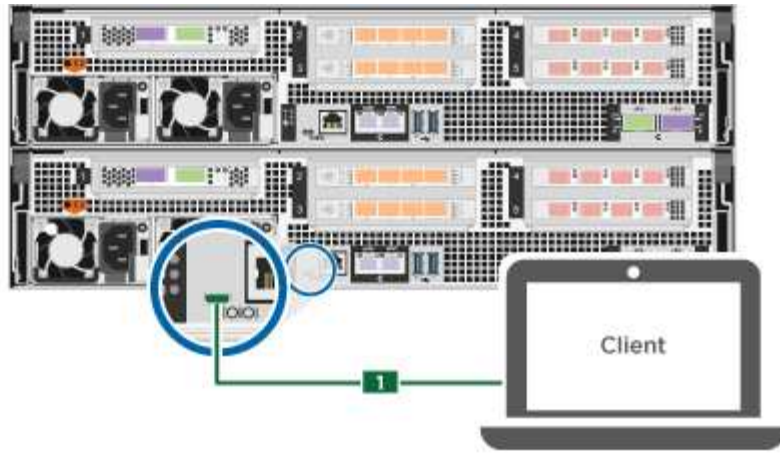

c. Connect the laptop or console to the switch on the management subnet.

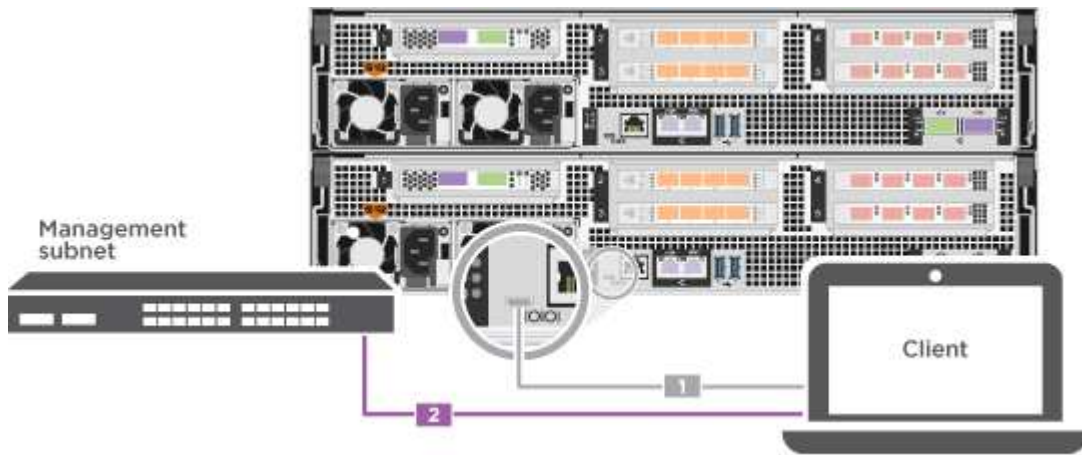

d. Assign a TCP/IP address to the laptop or console, using one that is on the management subnet.

2. Plug the power cords into the controller power supplies, and then connect them to power sources on different circuits.

The system begins to boot. Initial booting may take up to eight minutes.

3. Assign an initial node management IP address to one of the nodes.

If the management network has DHCP...	Then...
Configured	Record the IP address assigned to the new controllers.
Not configured	<p>a. Open a console session using PuTTY, a terminal server, or the equivalent for your environment.</p> <div style="display: flex; align-items: center; margin: 10px 0;"> <div style="text-align: center; margin-right: 10px;"> <span style="font-size: 2em;">i</span> </div> <div> <p>Check your laptop or console's online help if you do not know how to configure PuTTY.</p> </div> </div> <p>b. Enter the management IP address when prompted by the script.</p>

4. Using System Manager on your laptop or console, configure your cluster:

- a. Point your browser to the node management IP address.



The format for the address is `https://x.x.x.x`.

- b. Configure the system using the data you collected in the [ONTAP Configuration Guide](#).
5. Verify the health of your system by running Config Advisor.
6. After you have completed the initial configuration, go to the [ONTAP & ONTAP System Manager Documentation Resources](#) page for information about configuring additional features in ONTAP.

## Maintain

### Maintain ASA C800 hardware

For the ASA C800 storage system, you can perform maintenance procedures on the following components.

#### Boot media

The boot media stores a primary and secondary set of boot image files that the system uses when it boots.

#### Chassis

The chassis is the physical enclosure housing all the controller components such as the controller/CPU unit, power supply, and I/O.

#### Controller

A controller consists of a board, firmware, and software. It controls the drives and implements the ONTAP functions.

#### DIMM

You must replace a DIMM (dual in-line memory module) when a memory mismatch is present, or you have a failed DIMM.

#### Drive

A drive is a device that provides the physical storage media for data.

#### Fan

The fan cools the controller.

#### NVDIMM

The NVDIMM (non-volatile dual in-line memory module) manages the data transfer from the volatile memory to the non-volatile storage, and maintains data integrity in the event of a power loss or system shutdown.

#### NVDIMM battery

A NVDIMM battery is responsible for maintaining power to the NVDIMM module.

## PCIe card

A PCIe (peripheral component interconnect express) card is an expansion card that plugs into the PCIe slot on the motherboard.

## Power supply

A power supply provides a redundant power source in a controller shelf.

## Real-time clock battery

A real time clock battery preserves system date and time information if the power is off.

## Boot media

### Overview of boot media replacement - ASA C800

- You must replace the failed component with a replacement FRU component you received from your provider.
- It is important that you apply the commands in these steps on the correct controller:
  - The *impaired* controller is the controller on which you are performing maintenance.
  - The *healthy* controller is the HA partner of the impaired controller.

### Check onboard encryption keys - ASA C800

Prior to shutting down the impaired controller and checking the status of the onboard encryption keys, you must check the status of the impaired controller, disable automatic giveback, and check which version of ONTAP is running on the system.

If you have a cluster with more than two nodes, it must be in quorum. If the cluster is not in quorum or a healthy controller shows false for eligibility and health, you must correct the issue before shutting down the impaired controller; see the [Synchronize a node with the cluster](#).

### Steps

1. Check the status of the impaired controller:
  - If the impaired controller is at the login prompt, log in as `admin`.
  - If the impaired controller is at the LOADER prompt and is part of HA configuration, log in as `admin` on the healthy controller.
  - If the impaired controller is in a standalone configuration and at LOADER prompt, contact [mysupport.netapp.com](http://mysupport.netapp.com).
2. If AutoSupport is enabled, suppress automatic case creation by invoking an AutoSupport message:

```
system node autosupport invoke -node * -type all -message  
MAINT=number_of_hours_downh
```

The following AutoSupport message suppresses automatic case creation for two hours: `cluster1:*>`

```
system node autosupport invoke -node * -type all -message MAINT=2h
```
3. Check the version of ONTAP the system is running on the impaired controller if up, or on the partner controller if the impaired controller is down, using the `version -v` command:

- If <Ino-DARE> or <1Ono-DARE> is displayed in the command output, the system does not support NVE, proceed to shut down the controller.
  - If <Ino-DARE> is not displayed in the command output, and the system is running ONTAP 9.5, go to [Option 1: Check NVE or NSE on systems running ONTAP 9.5 and earlier](#).
  - If <Ino-DARE> is not displayed in the command output, and the system is running ONTAP 9.6 or later, go to [Option 2: Check NVE or NSE on systems running ONTAP 9.6 and later](#).
4. If the impaired controller is part of an HA configuration, disable automatic giveback from the healthy controller: `storage failover modify -node local -auto-giveback false` or `storage failover modify -node local -auto-giveback-after-panic false`

### Option 1: Check NVE or NSE on systems running ONTAP 9.5 and earlier

Before shutting down the impaired controller, you need to check whether the system has either NetApp Volume Encryption (NVE) or NetApp Storage Encryption (NSE) enabled. If so, you need to verify the configuration.

#### Steps

1. Connect the console cable to the impaired controller.
2. Check whether NVE is configured for any volumes in the cluster: `volume show -is-encrypted true`

If any volumes are listed in the output, NVE is configured and you need to verify the NVE configuration. If no volumes are listed, check whether NSE is configured.

3. Check whether NSE is configured: `storage encryption disk show`
  - If the command output lists the drive details with Mode & Key ID information, NSE is configured and you need to verify the NSE configuration.
  - If NVE and NSE are not configured, it's safe to shut down the impaired controller.

### Verify NVE configuration

#### Steps

1. Display the key IDs of the authentication keys that are stored on the key management servers: `security key-manager query`
  - If the `Restored` column displays `yes` and all key managers display `available`, it's safe to shut down the impaired controller.
  - If the `Restored` column displays anything other than `yes`, or if any key manager displays `unavailable`, you need to complete some additional steps.
  - If you see the message `This command is not supported when onboard key management is enabled`, you need to complete some other additional steps.
2. If the `Restored` column displayed anything other than `yes`, or if any key manager displayed `unavailable`:
  - a. Retrieve and restore all authentication keys and associated key IDs: `security key-manager restore -address *`

If the command fails, contact NetApp Support.

[mysupport.netapp.com](http://mysupport.netapp.com)
  - b. Verify that the `Restored` column displays `yes` for all authentication keys and that all key managers

display available: security key-manager query

c. Shut down the impaired controller.

3. If you saw the message This command is not supported when onboard key management is enabled, display the keys stored in the onboard key manager: `security key-manager key show -detail`

a. If the Restored column displays `yes` manually back up the onboard key management information:

- Go to advanced privilege mode and enter `y` when prompted to continue: `set -priv advanced`
- Enter the command to display the OKM backup information: `security key-manager backup show`
- Copy the contents of the backup information to a separate file or your log file. You'll need it in disaster scenarios where you might need to manually recover OKM.
- Return to admin mode: `set -priv admin`
- Shut down the impaired controller.

b. If the Restored column displays anything other than `yes`:

- Run the key-manager setup wizard: `security key-manager setup -node target/impaired node name`



Enter the customer's onboard key management passphrase at the prompt. If the passphrase cannot be provided, contact [mysupport.netapp.com](https://mysupport.netapp.com)

- Verify that the Restored column displays `yes` for all authentication key: `security key-manager key show -detail`
- Go to advanced privilege mode and enter `y` when prompted to continue: `set -priv advanced`
- Enter the command to display the OKM backup information: `security key-manager backup show`
- Copy the contents of the backup information to a separate file or your log file. You'll need it in disaster scenarios where you might need to manually recover OKM.
- Return to admin mode: `set -priv admin`
- You can safely shutdown the controller.

## Verify NSE configuration

### Steps

1. Display the key IDs of the authentication keys that are stored on the key management servers: `security key-manager query`
  - If the Restored column displays `yes` and all key managers display `available`, it's safe to shut down the impaired controller.
  - If the Restored column displays anything other than `yes`, or if any key manager displays `unavailable`, you need to complete some additional steps.
  - If you see the message This command is not supported when onboard key management is enabled, you need to complete some other additional steps
2. If the Restored column displayed anything other than `yes`, or if any key manager displayed `unavailable`:



- a. Retrieve and restore all authentication keys and associated key IDs: `security key-manager restore -address *`

If the command fails, contact NetApp Support.

[mysupport.netapp.com](https://mysupport.netapp.com)

- b. Verify that the `Restored` column displays `yes` for all authentication keys and that all key managers display `available: security key-manager query`
  - c. Shut down the impaired controller.
3. If you saw the message `This command is not supported when onboard key management is enabled`, display the keys stored in the onboard key manager: `security key-manager key show -detail`
    - a. If the `Restored` column displays `yes`, manually back up the onboard key management information:
      - Go to advanced privilege mode and enter `y` when prompted to continue: `set -priv advanced`
      - Enter the command to display the OKM backup information: `security key-manager backup show`
      - Copy the contents of the backup information to a separate file or your log file. You'll need it in disaster scenarios where you might need to manually recover OKM.
      - Return to admin mode: `set -priv admin`
      - Shut down the impaired controller.
    - b. If the `Restored` column displays anything other than `yes`:
      - Run the key-manager setup wizard: `security key-manager setup -node target/impaired node name`



Enter the customer's OKM passphrase at the prompt. If the passphrase cannot be provided, contact [mysupport.netapp.com](https://mysupport.netapp.com)
      - Verify that the `Restored` column shows `yes` for all authentication keys: `security key-manager key show -detail`
      - Go to advanced privilege mode and enter `y` when prompted to continue: `set -priv advanced`
      - Enter the command to back up the OKM information: `security key-manager backup show`



Make sure that OKM information is saved in your log file. This information will be needed in disaster scenarios where OKM might need to be manually recovered.
      - Copy the contents of the backup information to a separate file or your log. You'll need it in disaster scenarios where you might need to manually recover OKM.
      - Return to admin mode: `set -priv admin`
      - You can safely shut down the controller.

## Option 2: Check NVE or NSE on systems running ONTAP 9.6 and later

Before shutting down the impaired controller, you need to verify whether the system has either NetApp Volume Encryption (NVE) or NetApp Storage Encryption (NSE) enabled. If so, you need to verify the configuration.

1. Verify whether NVE is in use for any volumes in the cluster: `volume show -is-encrypted true`

If any volumes are listed in the output, NVE is configured and you need to verify the NVE configuration. If no volumes are listed, check whether NSE is configured and in use.

2. Verify whether NSE is configured and in use: `storage encryption disk show`
  - If the command output lists the drive details with Mode & Key ID information, NSE is configured and you need to verify the NSE configuration and in use.
  - If no disks are shown, NSE is not configured.
  - If NVE and NSE are not configured, no drives are protected with NSE keys, it's safe to shut down the impaired controller.

## Verify NVE configuration

1. Display the key IDs of the authentication keys that are stored on the key management servers: `security key-manager key query`



After the ONTAP 9.6 release, you may have additional key manager types. The types are KMIP, AKV, and GCP. The process for confirming these types is the same as confirming external or onboard key manager types.

- If the Key Manager type displays `external` and the Restored column displays `yes`, it's safe to shut down the impaired controller.
  - If the Key Manager type displays `onboard` and the Restored column displays `yes`, you need to complete some additional steps.
  - If the Key Manager type displays `external` and the Restored column displays anything other than `yes`, you need to complete some additional steps.
  - If the Key Manager type displays `onboard` and the Restored column displays anything other than `yes`, you need to complete some additional steps.
2. If the Key Manager type displays `onboard` and the Restored column displays `yes`, manually back up the OKM information:
    - a. Go to advanced privilege mode and enter `y` when prompted to continue: `set -priv advanced`
    - b. Enter the command to display the key management information: `security key-manager onboard show-backup`
    - c. Copy the contents of the backup information to a separate file or your log file. You'll need it in disaster scenarios where you might need to manually recover OKM.
    - d. Return to admin mode: `set -priv admin`
    - e. Shut down the impaired controller.
  3. If the Key Manager type displays `external` and the Restored column displays anything other than `yes`:
    - a. Restore the external key management authentication keys to all nodes in the cluster: `security key-manager external restore`

If the command fails, contact NetApp Support.

- b. Verify that the `Restored` column equals `yes` for all authentication keys: `security key-manager key query`
  - c. Shut down the impaired controller.
4. If the `Key Manager` type displays `onboard` and the `Restored` column displays anything other than `yes`:
- a. Enter the onboard security key-manager sync command: `security key-manager onboard sync`



Enter the customer's 32 character, alphanumeric onboard key management passphrase at the prompt. If the passphrase cannot be provided, contact NetApp Support. [mysupport.netapp.com](https://mysupport.netapp.com)

- b. Verify the `Restored` column shows `yes` for all authentication keys: `security key-manager key query`
- c. Verify that the `Key Manager` type shows `onboard`, and then manually back up the OKM information.
- d. Go to advanced privilege mode and enter `y` when prompted to continue: `set -priv advanced`
- e. Enter the command to display the key management backup information: `security key-manager onboard show-backup`
- f. Copy the contents of the backup information to a separate file or your log file. You'll need it in disaster scenarios where you might need to manually recover OKM.
- g. Return to admin mode: `set -priv admin`
- h. You can safely shut down the controller.

## Verify NSE configuration

1. Display the key IDs of the authentication keys that are stored on the key management servers: `security key-manager key query -key-type NSE-AK`



After the ONTAP 9.6 release, you may have additional key manager types. The types are `KMIP`, `AKV`, and `GCP`. The process for confirming these types is the same as confirming `external` or `onboard` key manager types.

- If the `Key Manager` type displays `external` and the `Restored` column displays `yes`, it's safe to shut down the impaired controller.
  - If the `Key Manager` type displays `onboard` and the `Restored` column displays `yes`, you need to complete some additional steps.
  - If the `Key Manager` type displays `external` and the `Restored` column displays anything other than `yes`, you need to complete some additional steps.
  - If the `Key Manager` type displays `external` and the `Restored` column displays anything other than `yes`, you need to complete some additional steps.
2. If the `Key Manager` type displays `onboard` and the `Restored` column displays `yes`, manually back up the OKM information:
- a. Go to advanced privilege mode and enter `y` when prompted to continue: `set -priv advanced`
  - b. Enter the command to display the key management information: `security key-manager onboard`

`show-backup`

- c. Copy the contents of the backup information to a separate file or your log file. You'll need it in disaster scenarios where you might need to manually recover OKM.
  - d. Return to admin mode: `set -priv admin`
  - e. You can safely shut down the controller.
3. If the `Key Manager` type displays `external` and the `Restored` column displays anything other than `yes`:
- a. Restore the external key management authentication keys to all nodes in the cluster: `security key-manager external restore`

If the command fails, contact NetApp Support.

[mysupport.netapp.com](https://mysupport.netapp.com)

- b. Verify that the `Restored` column equals `yes` for all authentication keys: `security key-manager key query`
  - c. You can safely shut down the controller.
4. If the `Key Manager` type displays `onboard` and the `Restored` column displays anything other than `yes`:
- a. Enter the onboard security key-manager sync command: `security key-manager onboard sync`
- Enter the customer's 32 character, alphanumeric onboard key management passphrase at the prompt. If the passphrase cannot be provided, contact NetApp Support.

[mysupport.netapp.com](https://mysupport.netapp.com)

- b. Verify the `Restored` column shows `yes` for all authentication keys: `security key-manager key query`
- c. Verify that the `Key Manager` type shows `onboard`, and then manually back up the OKM information.
- d. Go to advanced privilege mode and enter `y` when prompted to continue: `set -priv advanced`
- e. Enter the command to display the key management backup information: `security key-manager onboard show-backup`
- f. Copy the contents of the backup information to a separate file or your log file. You'll need it in disaster scenarios where you might need to manually recover OKM.
- g. Return to admin mode: `set -priv admin`
- h. You can safely shut down the controller.

### Shut down the controller - ASA C800

After completing the NVE or NSE tasks, you need to complete the shutdown of the impaired controller. Shut down or take over the impaired controller using the appropriate procedure for your configuration.

#### Option 1: Most systems

After completing the NVE or NSE tasks, you need to complete the shutdown of the impaired controller.

## Steps

- a. Take the impaired controller to the LOADER prompt:

If the impaired controller displays...	Then...
The LOADER prompt	Go to Remove controller module.
Waiting for giveback...	Press Ctrl-C, and then respond <code>y</code> when prompted.
System prompt or password prompt (enter system password)	Take over or halt the impaired controller from the healthy controller: <code>storage failover takeover -ofnode impaired_node_name</code>  When the impaired controller shows Waiting for giveback..., press Ctrl-C, and then respond <code>y</code> .

- b. From the LOADER prompt, enter: `printenv` to capture all boot environmental variables. Save the output to your log file.



This command may not work if the boot device is corrupted or non-functional.

## Option 2: System is in a MetroCluster



Do not use this procedure if your system is in a two-node MetroCluster configuration.

To shut down the impaired controller, you must determine the status of the controller and, if necessary, take over the controller so that the healthy controller continues to serve data from the impaired controller storage.

- If you have a cluster with more than two nodes, it must be in quorum. If the cluster is not in quorum or a healthy controller shows false for eligibility and health, you must correct the issue before shutting down the impaired controller; see [Synchronize a node with the cluster](#).
- If you have a MetroCluster configuration, you must have confirmed that the MetroCluster Configuration State is configured and that the nodes are in an enabled and normal state (`metrocluster node show`).

## Steps

1. If AutoSupport is enabled, suppress automatic case creation by invoking an AutoSupport message:

```
system node autosupport invoke -node * -type all -message  
MAINT=number_of_hours_downh
```

The following AutoSupport message suppresses automatic case creation for two hours: `cluster1:*>`

```
system node autosupport invoke -node * -type all -message MAINT=2h
```

2. Disable automatic giveback from the console of the healthy controller: `storage failover modify -node local -auto-giveback false`
3. Take the impaired controller to the LOADER prompt:

If the impaired controller is displaying...	Then...
The LOADER prompt	Go to the next step.
Waiting for giveback...	Press Ctrl-C, and then respond <i>y</i> when prompted.
System prompt or password prompt (enter system password)	<p>Take over or halt the impaired controller from the healthy controller:</p> <pre>storage failover takeover -ofnode impaired_node_name</pre> <p>When the impaired controller shows Waiting for giveback..., press Ctrl-C, and then respond <i>y</i>.</p>

## Replace the boot media - ASA C800

To replace the boot media, you must remove the impaired controller module, install the replacement boot media, and transfer the boot image to a USB flash drive.

### Step 1: Remove the controller module

You must remove the controller module from the chassis when you replace the controller module or replace a component inside the controller module.

1. If you are not already grounded, properly ground yourself.
2. Unplug the controller module power supplies from the source.
3. Release the power cable retainers, and then unplug the cables from the power supplies.
4. Loosen the hook and loop strap binding the cables to the cable management device, and then unplug the system cables and SFP and QSFP modules (if needed) from the controller module, keeping track of where the cables were connected.

Leave the cables in the cable management device so that when you reinstall the cable management device, the cables are organized.

5. Remove the cable management device from the controller module and set it aside.
6. Press down on both of the locking latches, and then rotate both latches downward at the same time.

The controller module moves slightly out of the chassis.

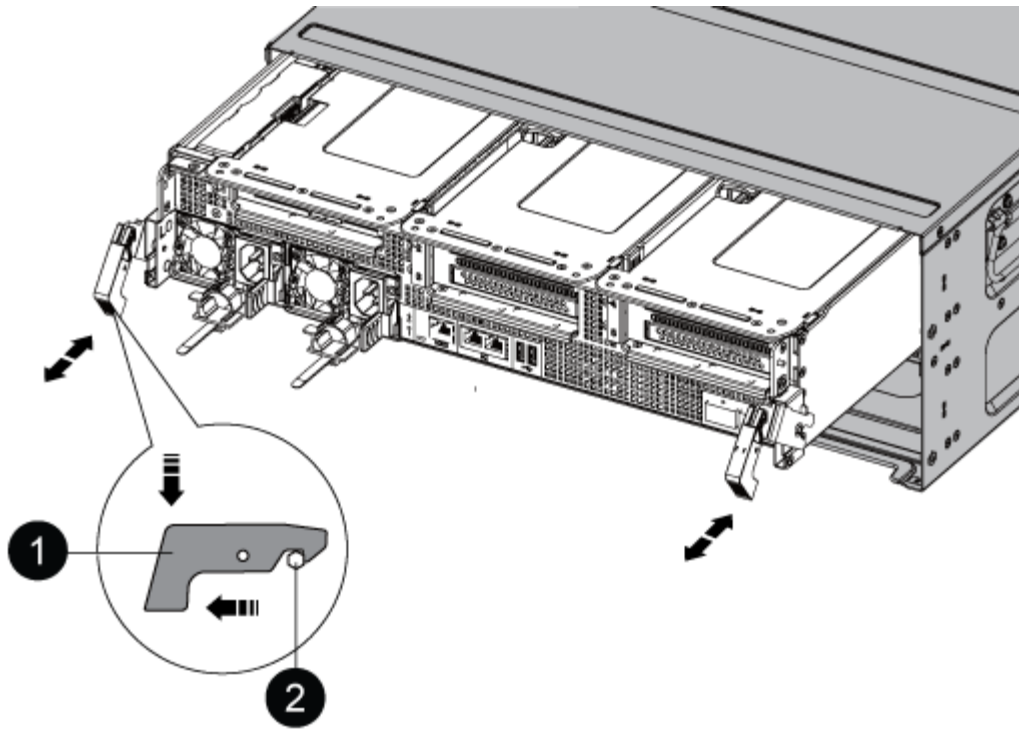

1	Locking latch
2	Locking pin

7. Slide the controller module out of the chassis.

Make sure that you support the bottom of the controller module as you slide it out of the chassis.

8. Place the controller module on a stable, flat surface, and then open the air duct:

- a. Press in the locking tabs on the sides of the air duct toward the middle of the controller module.
- b. Slide the air duct toward the fan modules, and then rotate it upward to its completely open position.

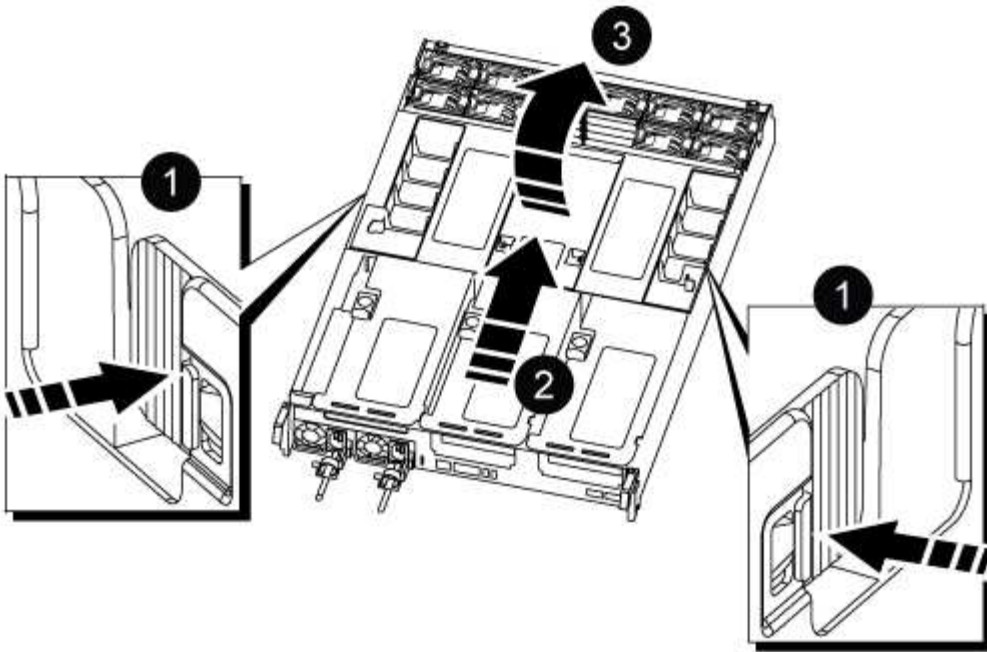

1	Air duct locking tabs
2	Slide air duct towards fan modules
3	Rotate air duct towards fan modules

**Step 2: Replace the boot media**

You locate the failed boot media in the controller module by removing Riser 3 on the controller module before you can replace the boot media.

You need a Phillips head screwdriver to remove the screw that holds the boot media in place.

1. Locate the boot media:



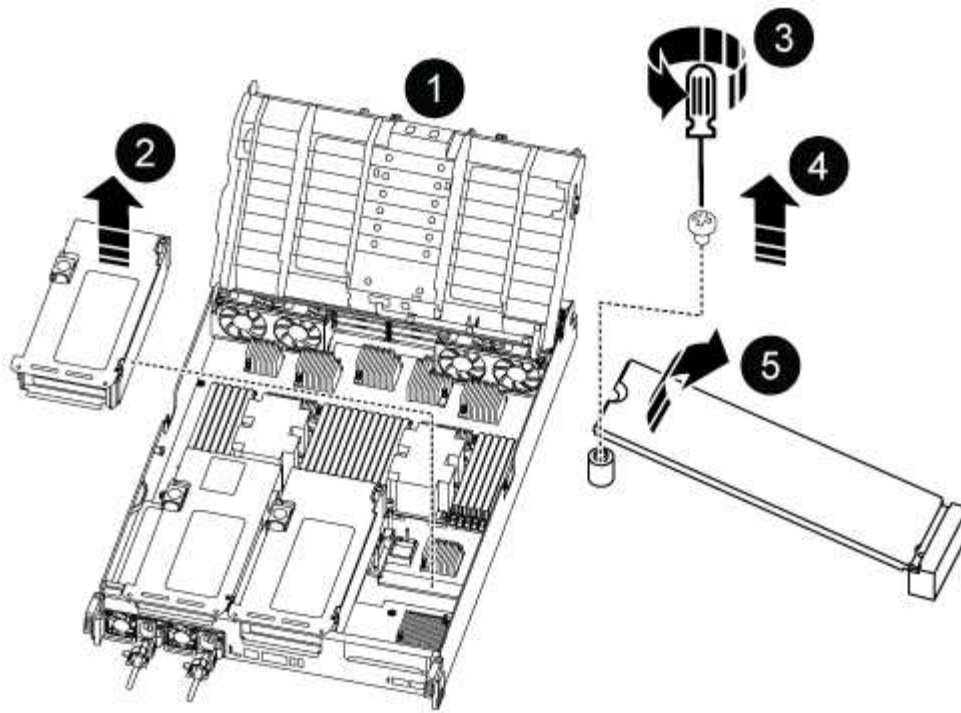

1	Air duct
2	Riser 3
3	Phillips #1 screwdriver
4	Boot media screw
5	Boot media

2. Remove the boot media from the controller module:

- a. Using a #1 Phillips head screwdriver, remove the screw holding down the boot media and set the screw aside in a safe place.
- b. Grasping the sides of the boot media, gently rotate the boot media up, and then pull the boot media straight out of the socket and set it aside.

3. Install the replacement boot media into the controller module:

- a. Align the edges of the boot media with the socket housing, and then gently push it squarely into the socket.
- b. Rotate the boot media down toward the motherboard.
- c. Secure the boot media to the motherboard using the boot media screw.

Do not over-tighten the screw or you might damage the boot media.

4. Reinstall the riser into the controller module.

5. Close the air duct:
  - a. Rotate the air duct downward.
  - b. Slide the air duct toward the risers until it clicks into place.

### Step 3: Transfer the boot image to the boot media

The replacement boot media that you installed is without a boot image so you need to transfer a boot image using a USB flash drive.

#### Before you begin

- You must have a USB flash drive, formatted to FAT32, with at least 4GB capacity.
- A copy of the same image version of ONTAP as what the impaired controller was running. You can download the appropriate image from the Downloads section on the NetApp Support Site
  - If NVE is enabled, download the image with NetApp Volume Encryption, as indicated in the download button.
  - If NVE is not enabled, download the image without NetApp Volume Encryption, as indicated in the download button.
- If your system is an HA pair, you must have a network connection.
- If your system is a stand-alone system you do not need a network connection, but you must perform an additional reboot when restoring the var file system.

#### Steps

1. Download and copy the appropriate service image from the NetApp Support Site to the USB flash drive.
  - a. Download the service image to your work space on your laptop.
  - b. Unzip the service image.



If you are extracting the contents using Windows, do not use WinZip to extract the netboot image. Use another extraction tool, such as 7-Zip or WinRAR.

There are two folders in the unzipped service image file:

- boot
- efi

- c. Copy the efi folder to the top directory on the USB flash drive.

The USB flash drive should have the efi folder and the same Service Image (BIOS) version of what the impaired controller is running.

- d. Remove the USB flash drive from your laptop.
2. If you have not already done so, close the air duct:
  - a. Swing the air duct all the way down to the controller module.
  - b. Slide the air duct toward the risers until the locking tabs click into place.
  - c. Inspect the air duct to make sure that it is properly seated and locked into place.

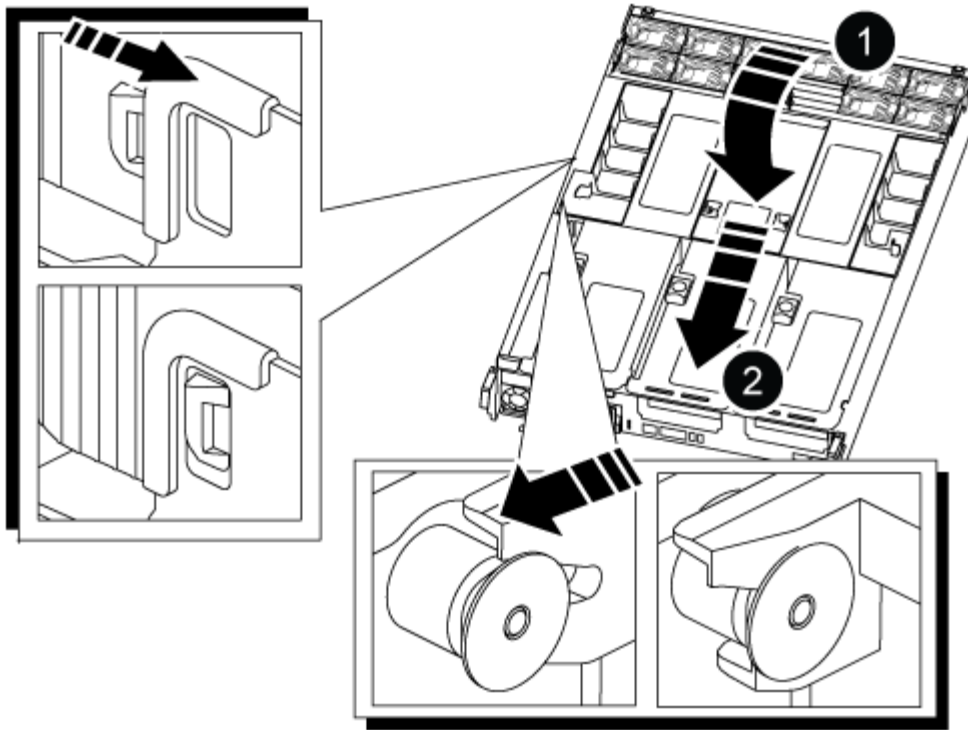

1	Air duct
2	Risers

3. Align the end of the controller module with the opening in the chassis, and then gently push the controller module halfway into the system.

4. Reinstall the cable management device and recable the system, as needed.

When recabling, remember to reinstall the media converters (SFPs or QSFPs) if they were removed.

5. Plug the power cable into the power supply and reinstall the power cable retainer.

6. Insert the USB flash drive into the USB slot on the controller module.

Make sure that you install the USB flash drive in the slot labeled for USB devices, and not in the USB console port.

7. Gently push the controller module all the way into the system until the controller module locking hooks begin to rise, firmly push on the locking hooks to finish seating the controller module, and then swing the locking hooks into the locked position over the pins on the controller module.

The controller begins to boot as soon as it is completely installed into the chassis.

8. Interrupt the boot process by pressing Ctrl-C to stop at the LOADER prompt.

If you miss this message, press Ctrl-C, select the option to boot to Maintenance mode, and then halt the controller to boot to LOADER.

## Boot the recovery image - ASA C800

You must boot the ONTAP image from the USB drive, restore the file system, and verify the environmental variables.

1. From the LOADER prompt, boot the recovery image from the USB flash drive: `boot_recovery`

The image is downloaded from the USB flash drive.

2. When prompted, either enter the name of the image or accept the default image displayed inside the brackets on your screen.
3. Restore the var file system:

If your system has...	Then...
A network connection	<ol style="list-style-type: none"><li>a. Press <code>y</code> when prompted to restore the backup configuration.</li><li>b. Set the healthy controller to advanced privilege level: <code>set -privilege advanced</code></li><li>c. Run the restore backup command: <code>system node restore-backup -node local -target-address <i>impaired_node_IP_address</i></code></li><li>d. Return the controller to admin level: <code>set -privilege admin</code></li><li>e. Press <code>y</code> when prompted to use the restored configuration.</li><li>f. Press <code>y</code> when prompted to reboot the controller.</li></ol>
No network connection	<ol style="list-style-type: none"><li>a. Press <code>n</code> when prompted to restore the backup configuration.</li><li>b. Reboot the system when prompted by the system.</li><li>c. Select the <b>Update flash from backup config</b> (sync flash) option from the displayed menu.  If you are prompted to continue with the update, press <code>y</code>.</li></ol>

If your system has...	Then...
No network connection and is in a MetroCluster IP configuration	<p>a. Press <b>n</b> when prompted to restore the backup configuration.</p> <p>b. Reboot the system when prompted by the system.</p> <p>c. Wait for the iSCSI storage connections to connect.</p> <p>You can proceed after you see the following messages:</p> <pre data-bbox="672 394 1484 1255"> date-and-time [node- name:iscsi.session.stateChanged:notice]: iSCSI session state is changed to Connected for the target iSCSI-target (type: dr_auxiliary, address: ip-address). date-and-time [node- name:iscsi.session.stateChanged:notice]: iSCSI session state is changed to Connected for the target iSCSI-target (type: dr_partner, address: ip-address). date-and-time [node- name:iscsi.session.stateChanged:notice]: iSCSI session state is changed to Connected for the target iSCSI-target (type: dr_auxiliary, address: ip-address). date-and-time [node- name:iscsi.session.stateChanged:notice]: iSCSI session state is changed to Connected for the target iSCSI-target (type: dr_partner, address: ip-address). </pre> <p>d. Select the <b>Update flash from backup config</b> (sync flash) option from the displayed menu.</p> <p>If you are prompted to continue with the update, press <b>y</b>.</p>

4. Ensure that the environmental variables are set as expected:

- a. Take the controller to the **LOADER** prompt.
- b. Check the environment variable settings with the `printenv` command.
- c. If an environment variable is not set as expected, modify it with the `setenv environment_variable_name changed_value` command.
- d. Save your changes using the `savenv` command.

5. The next depends on your system configuration:

- If your system has onboard keymanager, NSE or NVE configured, go to [Restore OKM, NSE, and NVE as needed](#)

- If your system does not have onboard keymanager, NSE or NVE configured, complete the steps in this section.

6. From the LOADER prompt, enter the `boot_ontap` command.

If you see...	Then...
The login prompt	Go to the next Step.
Waiting for giveback...	<ol style="list-style-type: none"> <li>Log into the partner controller.</li> <li>Confirm the target controller is ready for giveback with the <code>storage failover show</code> command.</li> </ol>

- Connect the console cable to the partner controller.
- Give back the controller using the `storage failover giveback -fromnode local` command
- At the cluster prompt, check the logical interfaces with the `net int -is-home false` command.

If any interfaces are listed as "false", revert those interfaces back to their home port using the `net int revert` command.

- Move the console cable to the repaired controller and run the `version -v` command to check the ONTAP versions.
- Restore automatic giveback if you disabled it by using the `storage failover modify -node local -auto-giveback true` command.

### Restore OKM, NSE, and NVE as needed - ASA C800

Once environment variables are checked, you must complete steps specific to systems that have Onboard Key Manager (OKM), NetApp Storage Encryption (NSE) or NetApp Volume Encryption (NVE) enabled.

Determine which section you should use to restore your OKM, NSE, or NVE configurations:

If NSE or NVE are enabled along with Onboard Key Manager you must restore settings you captured at the beginning of this procedure.

- If NSE or NVE are enabled and Onboard Key Manager is enabled, go to [Option 1: Restore NVE or NSE when Onboard Key Manager is enabled](#).
- If NSE or NVE are enabled for ONATP 9.5, go to [Option 2: Restore NSE/NVE on systems running ONTAP 9.5 and earlier](#).
- If NSE or NVE are enabled for ONTAP 9.6, go to [Option 3: Restore NSE/NVE on systems running ONTAP 9.6 and later](#).

### Option 1: Restore NVE or NSE when Onboard Key Manager is enabled

#### Steps

- Connect the console cable to the target controller.
- Use the `boot_ontap` command at the LOADER prompt to boot the controller.

3. Check the console output:

If the console displays...	Then...
The LOADER prompt	Boot the controller to the boot menu: <code>boot_ontap menu</code>
Waiting for giveback...	<ol style="list-style-type: none"> <li>Enter <code>Ctrl-C</code> at the prompt</li> <li>At the message: <code>Do you wish to halt this controller rather than wait [y/n]?</code> , enter: <code>y</code></li> <li>At the LOADER prompt, enter the <code>boot_ontap menu</code> command.</li> </ol>

- At the Boot Menu, enter the hidden command, `recover_onboard_keymanager` and reply `y` at the prompt.
- Enter the passphrase for the onboard key manager you obtained from the customer at the beginning of this procedure.
- When prompted to enter the backup data, paste the backup data you captured at the beginning of this procedure, when asked. Paste the output of `security key-manager backup show` OR `security key-manager onboard show-backup` command.



The data is output from either `security key-manager backup show` or `security key-manager onboard show-backup` command.

Example of backup data:

```

-----BEGIN BACKUP-----
TmV0QXBwIEtleSBCbG9iAAEAAAAEAAAAcAEAAAAAADuD+byAAAAACEAAAAAAAA
QAAAAAAAAABvOIH0AAAAAMh7qDLRyH1DBz12piVdy9ATSFMT0C0TIYFss4PDjTaV
dzRYkLd1PhQLxAWJwOlyqSr8qY1SEBgm1IWgE5DLRqkiAAAAAAAAACgAAAAAAAA
3WTh7gAAAAAAAAAAAAAAAAAIAAAAAAAgAZJEIWvdeHr5RCAvHGclo+wAAAAAAAA
lgAAAAAAAAoAAAAAAAAEOTcR0AAAAAAAAAAAAAAAAACAAAAAAAAJAGr3tJA/
LRzUQRHwv+1aWvAAAAAAAAAACQAAAAAAAAAgAAAAAAAAACdhTcvAAAAAJ1PXeBf
ml4NBsSyV1B4jc4A7cvWEFY6ILG6hc6tbKLAHZuvfQ4rlbYAAAAAAAAAAAAAAAA
AAAAAAAAAAAAAAAAAAAAAAAAAAAAAAAAAAAAAAAAAAAAAAAAAAAAAAAAAAAAAAAA
AAAAAAAAAAAAAAAAAAAAAAAAAAAAAAAAAAAAAAAAAAAAAAAAAAAAAAAAAAAAAAAA
.
.
.
.
H4nPQM0nrDRYRa9SCv8AAAAAAAAAAAAAAAAAAAAAAAAAAAAAAAAAAAAAAAAAAAA
AAAAAAAAAAAAAAAAAAAAAAAAAAAAAAAAAAAAAAAAAAAAAAAAAAAAAAAAAAAAAAAA
AAAAAAA
-----END BACKUP-----

```

- At the Boot Menu select the option for Normal Boot.

The system boots to `Waiting for giveback...` prompt.

8. Move the console cable to the partner controller and login as admin.
9. Confirm the target controller is ready for giveback with the `storage failover show` command.
10. Give back only the CFO aggregates with the `storage failover giveback -fromnode local -only-cfo -aggregates true` command.
  - If the command fails because of a failed disk, physically disengage the failed disk, but leave the disk in the slot until a replacement is received.
  - If the command fails because of an open CIFS session, check with the customer on how to close out CIFS sessions.



Terminating CIFS can cause loss of data.

- If the command fails because the partner is "not ready", wait 5 minutes for the NVMEMs to synchronize.
  - If the command fails because of an NDMP, SnapMirror, or SnapVault process, disable the process. See the appropriate Documentation Center for more information.
11. Once the giveback completes, check the failover and giveback status with the `storage failover show` and ``storage failover show-giveback`` commands.

Only the CFO aggregates (root aggregate and CFO style data aggregates) will be shown.

12. Move the console cable to the target controller.
13. If you are running ONTAP 9.5 and earlier, run the key-manager setup wizard:
  - a. Start the wizard using the `security key-manager setup -nodenodename` command, and then enter the passphrase for onboard key management when prompted.
  - b. Enter the `key-manager key show -detail` command to see a detailed view of all keys stored in the onboard key manager and verify that the `Restored` column = `yes` for all authentication keys.



If the `Restored` column = anything other than `yes`, contact Customer Support.

- c. Wait 10 minutes for the key to synchronize across the cluster.
14. If you are running ONTAP 9.6 or later:
  - a. Run the `security key-manager onboard sync` command and then enter the passphrase when prompted.
  - b. Enter the `security key-manager key query` command to see a detailed view of all keys stored in the onboard key manager and verify that the `Restored` column = `yes/true` for all authentication keys.



If the `Restored` column = anything other than `yes/true`, contact Customer Support.

- c. Wait 10 minutes for the key to synchronize across the cluster.
15. Move the console cable to the partner controller.
16. Give back the target controller using the `storage failover giveback -fromnode local` command.
17. Check the giveback status, 3 minutes after it reports complete, using the `storage failover show` command.



If giveback is not complete after 20 minutes, contact Customer Support.

18. At the clustershell prompt, enter the `net int show -is-home false` command to list the logical interfaces that are not on their home controller and port.

If any interfaces are listed as `false`, revert those interfaces back to their home port using the `net int revert -vserver Cluster -lif nodename` command.

19. Move the console cable to the target controller and run the `version -v` command to check the ONTAP versions.
20. Restore automatic giveback if you disabled it by using the `storage failover modify -node local -auto-giveback true` command.

## Option 2: Restore NSE/NVE on systems running ONTAP 9.5 and earlier

### Steps

1. Connect the console cable to the target controller.
2. Use the `boot_ontap` command at the LOADER prompt to boot the controller.
3. Check the console output:

If the console displays...	Then...
The login prompt	Go to Step 7.
Waiting for giveback...	<ol style="list-style-type: none"><li>a. Log into the partner controller.</li><li>b. Confirm the target controller is ready for giveback with the <code>storage failover show</code> command.</li></ol>

4. Move the console cable to the partner controller and give back the target controller storage using the `storage failover giveback -fromnode local -only-cfo-aggregates true local` command.
  - If the command fails because of a failed disk, physically disengage the failed disk, but leave the disk in the slot until a replacement is received.
  - If the command fails because of an open CIFS sessions, check with customer how to close out CIFS sessions.



Terminating CIFS can cause loss of data.

- If the command fails because the partner "not ready", wait 5 minutes for the NVMEMs to synchronize.
  - If the command fails because of an NDMP, SnapMirror, or SnapVault process, disable the process. See the appropriate Documentation Center for more information.
5. Wait 3 minutes and check the failover status with the `storage failover show` command.
  6. At the clustershell prompt, enter the `net int show -is-home false` command to list the logical interfaces that are not on their home controller and port.

If any interfaces are listed as `false`, revert those interfaces back to their home port using the `net int`

```
revert -vserver Cluster -lif nodename command.
```

7. Move the console cable to the target controller and run the `version -v` command to check the ONTAP versions.
8. Restore automatic giveback if you disabled it by using the `storage failover modify -node local -auto-giveback true` command.
9. Use the `storage encryption disk show` at the clustershell prompt, to review the output.



This command does not work if NVE (NetApp Volume Encryption) is configured

10. Use the `security key-manager query` to display the key IDs of the authentication keys that are stored on the key management servers.
  - If the `Restored` column = `yes` and all key managers report in an available state, go to *Complete the replacement process*.
  - If the `Restored` column = anything other than `yes`, and/or one or more key managers is not available, use the `security key-manager restore -address` command to retrieve and restore all authentication keys (AKs) and key IDs associated with all nodes from all available key management servers.

Check the output of the `security key-manager query` again to ensure that the `Restored` column = `yes` and all key managers report in an available state

11. If the Onboard Key Management is enabled:
  - a. Use the `security key-manager key show -detail` to see a detailed view of all keys stored in the onboard key manager.
  - b. Use the `security key-manager key show -detail` command and verify that the `Restored` column = `yes` for all authentication keys.

If the `Restored` column = anything other than `yes`, use the `security key-manager setup -node Repaired(Target)node` command to restore the Onboard Key Management settings. Rerun the `security key-manager key show -detail` command to verify `Restored` column = `yes` for all authentication keys.

12. Connect the console cable to the partner controller.
13. Give back the controller using the `storage failover giveback -fromnode local` command.
14. Restore automatic giveback if you disabled it by using the `storage failover modify -node local -auto-giveback true` command.

### Option 3: Restore NSE/NVE on systems running ONTAP 9.6 and later

#### Steps

1. Connect the console cable to the target controller.
2. Use the `boot_ontap` command at the LOADER prompt to boot the controller.
3. Check the console output:

If the console displays...	Then...
The login prompt	Go to Step 7.
Waiting for giveback...	<ul style="list-style-type: none"> <li>a. Log into the partner controller.</li> <li>b. Confirm the target controller is ready for giveback with the <code>storage failover show</code> command.</li> </ul>

4. Move the console cable to the partner controller and give back the target controller storage using the `storage failover giveback -fromnode local -only-cfo-aggregates true local` command.
  - If the command fails because of a failed disk, physically disengage the failed disk, but leave the disk in the slot until a replacement is received.
  - If the command fails because of an open CIFS session, check with the customer on how to close out CIFS sessions.



Terminating CIFS can cause loss of data.

- If the command fails because the partner is "not ready", wait 5 minutes for the NVMEMs to synchronize.
  - If the command fails because of an NDMP, SnapMirror, or SnapVault process, disable the process. See the appropriate Documentation Center for more information.
5. Wait 3 minutes and check the failover status with the `storage failover show` command.
  6. At the clustershell prompt, enter the `net int show -is-home false` command to list the logical interfaces that are not on their home controller and port.

If any interfaces are listed as `false`, revert those interfaces back to their home port using the `net int revert -vserver Cluster -lif nodename` command.

7. Move the console cable to the target controller and run the `version -v` command to check the ONTAP versions.
8. Restore automatic giveback if you disabled it by using the `storage failover modify -node local -auto-giveback true` command.
9. Use the `storage encryption disk show` at the clustershell prompt, to review the output.
10. Use the `security key-manager key query` command to display the key IDs of the authentication keys that are stored on the key management servers.
  - If the `Restored` column = `yes/true`, you are done and can proceed to complete the replacement process.
  - If the `Key Manager type` = `external` and the `Restored` column = anything other than `yes/true`, use the `security key-manager external restore` command to restore the key IDs of the authentication keys.



If the command fails, contact Customer Support.

- If the `Key Manager type = onboard` and the `Restored` column = anything other than `yes/true`, use the `security key-manager onboard sync` command to re-sync the Key Manager type.

Use the `security key-manager key query` to verify that the `Restored` column = `yes/true` for all authentication keys.

11. Connect the console cable to the partner controller.
12. Give back the controller using the `storage failover giveback -fromnode local` command.
13. Restore automatic giveback if you disabled it by using the `storage failover modify -node local -auto-giveback true` command.
14. If AutoSupport is enabled, restore/unsuppress automatic case creation by using the `system node autosupport invoke -node * -type all -message MAINT=END`

## Return the failed part to NetApp - ASA C800

Return the failed part to NetApp, as described in the RMA instructions shipped with the kit. See the [Part Return and Replacements](#) page for further information.

### Chassis

#### Replace the chassis - ASA C800

To replace the chassis, you must move the bezel, controller modules, and NVMe drives from the impaired chassis to the replacement chassis, and then remove the impaired chassis from the equipment rack or system cabinet and install the replacement chassis in its place.

All other components in the system must be functioning properly; if not, you must contact technical support.

- You can use this procedure with all versions of ONTAP supported by your system.
- This procedure is written with the assumption that you are moving the bezel, NVMe drives, and controller modules to the new chassis, and that the replacement chassis is a new component from NetApp.
- This procedure is disruptive. For a two-node cluster, you will have a complete service outage and a partial outage in a multi-node cluster.

#### Shut down the controllers - ASA C800

This procedure is for 2-node, non-MetroCluster configurations only. If you have a system with more than two nodes, see [How to perform a graceful shutdown and power up of one HA pair in a 4-node cluster](#).

#### Before you begin

You need:

- Local administrator credentials for ONTAP.
- NetApp onboard key management (OKM) cluster-wide passphrase if using storage encryption or NVE/NAE.
- BMC accessibility for each controller.

- Stop all clients/host from accessing data on the NetApp system.
- Suspend external backup jobs.
- Necessary tools and equipment for the replacement.



If the system is a NetApp StorageGRID or ONTAP S3 used as FabricPool cloud tier, refer to the [Gracefully shutdown and power up your storage system Resolution Guide](#) after performing this procedure.



If using SSDs, refer to [SU490: \(Impact: Critical\) SSD Best Practices: Avoid risk of drive failure and data loss if powered off for more than two months](#)

As a best practice before shutdown, you should:

- Perform additional [system health checks](#).
- Upgrade ONTAP to a recommended release for the system.
- Resolve any [Active IQ Wellness Alerts and Risks](#).  
Make note of any faults presently on the system, such as LEDs on the system components.

### Steps

1. Log into the cluster through SSH or log in from any node in the cluster using a local console cable and a laptop/console.
2. Turn off AutoSupport and indicate how long you expect the system to be offline:

```
system node autosupport invoke -node * -type all -message "MAINT=8h Power Maintenance"
```

3. Identify the SP/BMC address of all nodes:

```
system service-processor show -node * -fields address
```

4. Exit the cluster shell: `exit`
5. Log into SP/BMC over SSH using the IP address of any of the nodes listed in the output from the previous step.

If your're using a console/laptop, log into the controller using the same cluster administrator credentials.



Open an SSH session to every SP/BMC connection so that you can monitor progress.

6. Halt the 2 nodes located in the impaired chassis:

```
system node halt -node <node>,<node2> -skip-lif-migration-before-shutdown true -ignore-quorum-warnings true -inhibit-takeover true
```



For clusters using SnapMirror synchronous operating in StrictSync mode: `system node halt -node <node>,<node2> -skip-lif-migration-before-shutdown true -ignore-quorum-warnings true -inhibit-takeover true -ignore-strict -sync-warnings true`

7. Enter **y** for each controller in the cluster when you see *Warning: Are you sure you want to halt*

```
node "cluster <node-name> number"?  
{y|n}:
```

8. Wait for each controller to halt and display the LOADER prompt.

### Move and replace hardware - ASA C800

Move the power supplies, hard drives, and controller module from the impaired chassis to the new chassis, and swap out the impaired chassis with the new chassis of the same model as the impaired chassis.

#### Step 1: Remove the controller modules

To replace the chassis, you must remove the controller modules from the old chassis.

1. If you are not already grounded, properly ground yourself.
2. Release the power cable retainers, and then unplug the cables from the power supplies.
3. Loosen the hook and loop strap binding the cables to the cable management device, and then unplug the system cables from the controller module, keeping track of where the cables were connected.

Leave the cables in the cable management device so that when you reinstall the cable management device, the cables are organized.

4. Remove the cable management device from the controller module and set it aside.
5. Press down on both of the locking latches, and then rotate both latches downward at the same time.

The controller module moves slightly out of the chassis.

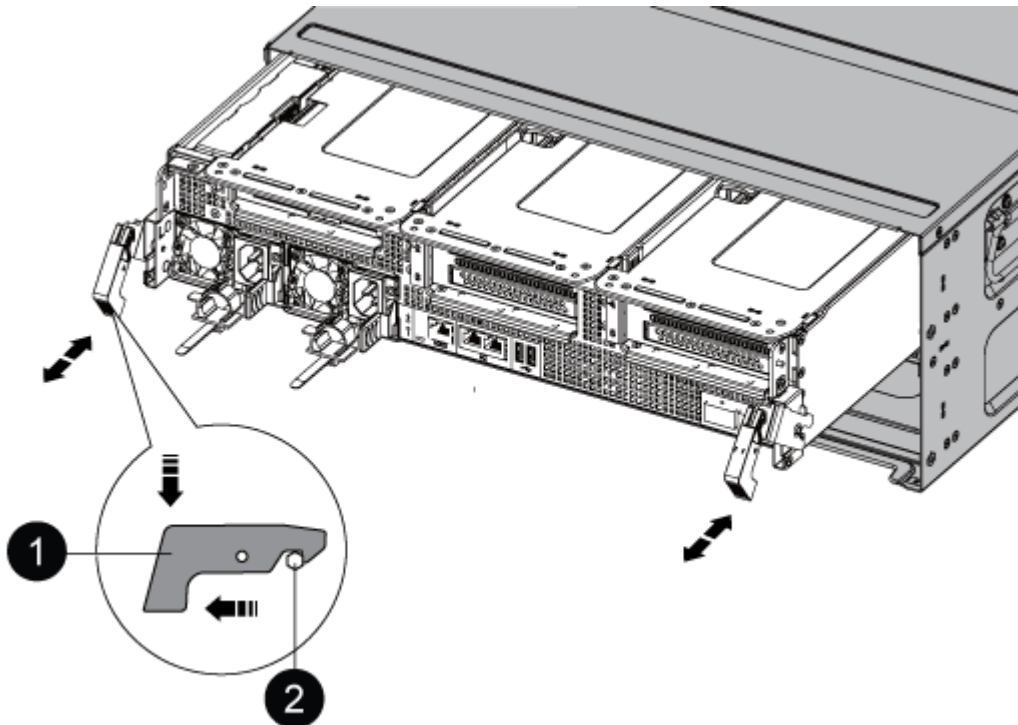

1	Locking latch
---	---------------

<b>2</b>	Locking pin
----------	-------------

6. Slide the controller module out of the chassis.

Make sure that you support the bottom of the controller module as you slide it out of the chassis.

7. Set the controller module aside in a safe place, and repeat these steps for the other controller module in the chassis.

## Step 2: Move drives to the new chassis

You need to move the drives from each bay opening in the old chassis to the same bay opening in the new chassis.

1. Gently remove the bezel from the front of the system.
2. Remove the drives:
  - a. Press the release button at the top of the carrier face below the LEDs.
  - b. Pull the cam handle to its fully open position to unseat the drive from the midplane, and then gently slide the drive out of the chassis.

The drive should disengage from the chassis, allowing it to slide free of the chassis.



When removing a drive, always use two hands to support its weight.



Drives are fragile. Handle them as little as possible to prevent damage to them.

3. Align the drive from the old chassis with the same bay opening in the new chassis.
4. Gently push the drive into the chassis as far as it will go.

The cam handle engages and begins to rotate upward.

5. Firmly push the drive the rest of the way into the chassis, and then lock the cam handle by pushing it up and against the drive holder.

Be sure to close the cam handle slowly so that it aligns correctly with the front of the drive carrier. It clicks when it is secure.

6. Repeat the process for the remaining drives in the system.

## Step 3: Replace a chassis from within the equipment rack or system cabinet

You must remove the existing chassis from the equipment rack or system cabinet before you can install the replacement chassis.

1. Remove the screws from the chassis mount points.
2. With two people, slide the old chassis off the rack rails in a system cabinet or equipment rack, and then set it aside.
3. If you are not already grounded, properly ground yourself.
4. Using two people, install the replacement chassis into the equipment rack or system cabinet by guiding the

chassis onto the rack rails in a system cabinet or equipment rack.

5. Slide the chassis all the way into the equipment rack or system cabinet.
6. Secure the front of the chassis to the equipment rack or system cabinet, using the screws you removed from the old chassis.
7. If you have not already done so, install the bezel.

#### Step 4: Install the controller modules

After you install the controller modules into the new chassis, you need to boot it.

For HA pairs with two controller modules in the same chassis, the sequence in which you install the controller module is especially important because it attempts to reboot as soon as you completely seat it in the chassis.

1. Align the end of the controller module with the opening in the chassis, and then gently push the controller module halfway into the system.



Do not completely insert the controller module in the chassis until instructed to do so.

2. Recable the console to the controller module, and then reconnect the management port.
3. Plug the power cables into the power supplies and reinstall the power cable retainers.
4. Complete the reinstallation of the controller module:
  - a. Firmly push the controller module into the chassis until it meets the midplane and is fully seated.

The locking latches rise when the controller module is fully seated.



Do not use excessive force when sliding the controller module into the chassis to avoid damaging the connectors.

The controller module begins to boot as soon as it is fully seated in the chassis. Be prepared to interrupt the boot process.

- b. Rotate the locking latches upward, tilting them so that they clear the locking pins, and then lower them into the locked position.
  - c. If you have not already done so, reinstall the cable management device.
  - d. Interrupt the normal boot process by pressing `Ctrl-C`.
5. Repeat the preceding steps to install the second controller into the new chassis.

#### Complete the restoration and replacement process - ASA C800

You must verify the HA state of the chassis and return the failed part to NetApp, as described in the RMA instructions shipped with the kit.

#### Step 1: Verify and set the HA state of the chassis

You must verify the HA state of the chassis, and, if necessary, update the state to match your system configuration.

1. In Maintenance mode, from either controller module, display the HA state of the local controller module and chassis: `ha-config show`



The HA state should be the same for all components.

2. If the displayed system state for the chassis does not match your system configuration:

a. Set the HA state for the chassis: `ha-config modify chassis HA-state`

The value for HA-state can be one of the following:

- ha
- mcc
- mccip
- non-ha

b. Confirm that the setting has changed: `ha-config show`

3. If you have not already done so, recable the rest of your system.

4. Reinstall the bezel on the front of the system.

## Step 2: Return the failed part to NetApp

Return the failed part to NetApp, as described in the RMA instructions shipped with the kit. See the [Part Return and Replacements](#) page for further information.

### Controller

#### Overview of controller module replacement - ASA C800

You must review the prerequisites for the replacement procedure and select the correct one for your version of the ONTAP operating system.

- All drive shelves must be working properly.
- The healthy controller must be able to take over the controller that is being replaced (referred to in this procedure as the “impaired controller”).
- If your system is in a MetroCluster configuration, you must review the section [Choosing the correct recovery procedure](#) to determine whether you should use this procedure.
- You must replace the failed component with a replacement FRU component you received from your provider.
- You must be replacing a controller module with a controller module of the same model type. You cannot upgrade your system by just replacing the controller module.
- You cannot change any drives or drive shelves as part of this procedure.
- In this procedure, the boot device is moved from the impaired controller to the *replacement* controller so that the *replacement* controller will boot up in the same version of ONTAP as the old controller module.
- It is important that you apply the commands in these steps on the correct systems:
  - The *impaired* controller is the controller that is being replaced.
  - The *replacement* controller is the new controller that is replacing the impaired controller.
  - The *healthy* controller is the surviving controller.
- You must always capture the controller’s console output to a text file.

This provides you a record of the procedure so that you can troubleshoot any issues that you might encounter during the replacement process.



Do not downgrade the BIOS version of the *replacement* controller to match the partner controller or the old controller module.

## Shut down the impaired controller - ASA C800

To shut down the impaired controller, you must determine the status of the controller and, if necessary, take over the controller so that the healthy controller continues to serve data from the impaired controller storage.

### About this task

- If you have a SAN system, you must have checked event messages (`cluster kernel-service show`) for the impaired controller SCSI blade. The `cluster kernel-service show` command (from `priv advanced` mode) displays the node name, quorum status of that node, availability status of that node, and operational status of that node.

Each SCSI-blade process should be in quorum with the other nodes in the cluster. Any issues must be resolved before you proceed with the replacement.

- If you have a cluster with more than two nodes, it must be in quorum. If the cluster is not in quorum or a healthy controller shows `false` for eligibility and health, you must correct the issue before shutting down the impaired controller; see [Synchronize a node with the cluster](#).

### Steps

1. If AutoSupport is enabled, suppress automatic case creation by invoking an AutoSupport message:  
`system node autosupport invoke -node * -type all -message MAINT=<# of hours>h`

The following AutoSupport message suppresses automatic case creation for two hours: `cluster1:>`  
`system node autosupport invoke -node * -type all -message MAINT=2h`

2. Disable automatic giveback from the console of the healthy controller: `storage failover modify -node local -auto-giveback false`



When you see *Do you want to disable auto-giveback?*, enter `y`.

3. Take the impaired controller to the LOADER prompt:

If the impaired controller is displaying...	Then...
The LOADER prompt	Go to the next step.
Waiting for giveback...	Press Ctrl-C, and then respond <code>y</code> when prompted.

If the impaired controller is displaying...	Then...
System prompt or password prompt	<p>Take over or halt the impaired controller from the healthy controller:  <code>storage failover takeover -ofnode  impaired_node_name</code></p> <p>When the impaired controller shows Waiting for giveback..., press Ctrl-C, and then respond <i>y</i>.</p>

## Replace the controller module hardware - ASA C800

To replace the controller, you must remove the impaired controller, move FRU components to the replacement controller module, install the replacement controller module in the chassis, and then boot the system to Maintenance mode.

### Step 1: Remove the controller module

You must remove the controller module from the chassis when you replace the controller module or replace a component inside the controller module.

1. On the front of the chassis, use your thumbs to firmly push each drive in until you feel a positive stop. This ensures that the drives are firmly seated against the chassis midplane.

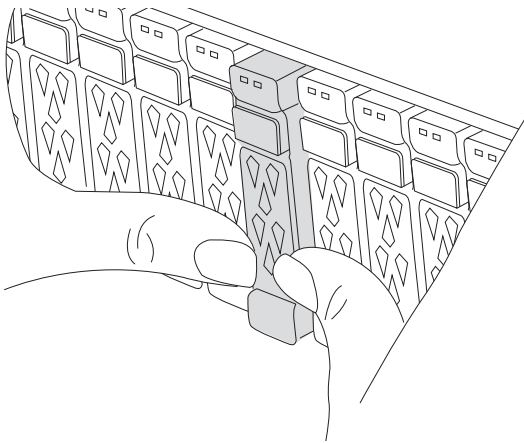

2. Go to the rear of the chassis. If you are not already grounded, properly ground yourself.
3. Unplug the controller module power supplies from the source.
4. Release the power cable retainers, and then unplug the cables from the power supplies.
5. Loosen the hook and loop strap binding the cables to the cable management device, and then unplug the system cables and SFP and QSFP modules (if needed) from the controller module, keeping track of where the cables were connected.

Leave the cables in the cable management device so that when you reinstall the cable management device, the cables are organized.

6. Remove the cable management device from the controller module and set it aside.
7. Press down on both of the locking latches, and then rotate both latches downward at the same time.

The controller module moves slightly out of the chassis.

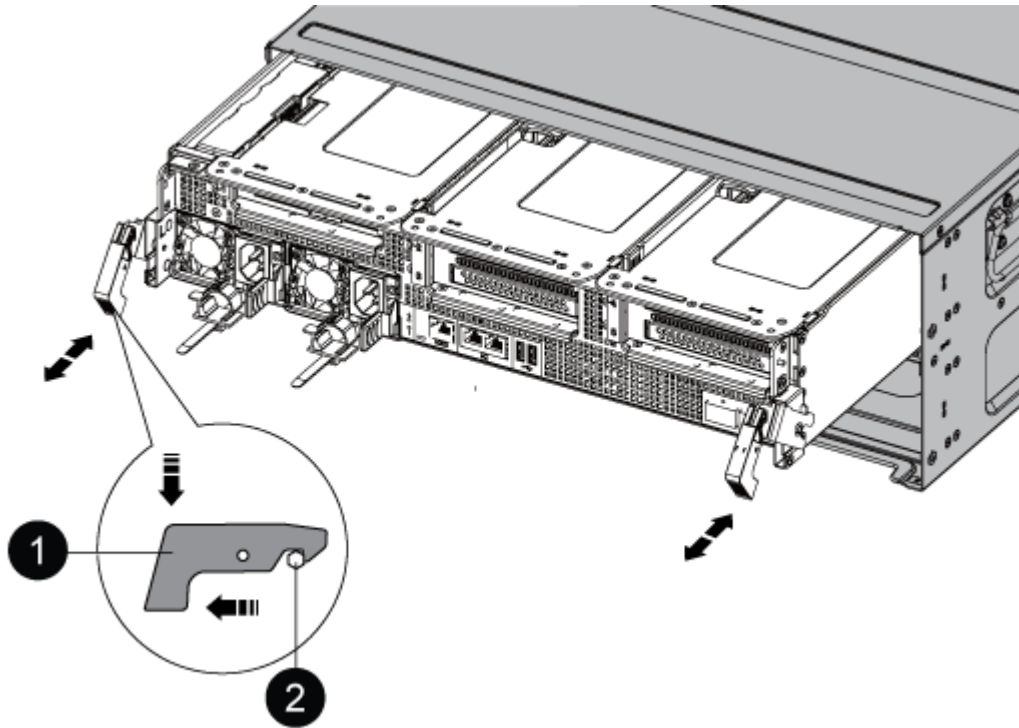

<b>1</b>	Locking latch
<b>2</b>	Locking pin

8. Slide the controller module out of the chassis and place it on a stable, flat surface.

Make sure that you support the bottom of the controller module as you slide it out of the chassis.

9. Place the controller module on a stable, flat surface.

10. Open the controller module air duct:

- a. Press in the locking tabs on the sides of the air duct toward the middle of the controller module.
- b. Slide the air duct toward the fan modules, and then rotate it upward to its completely open position.

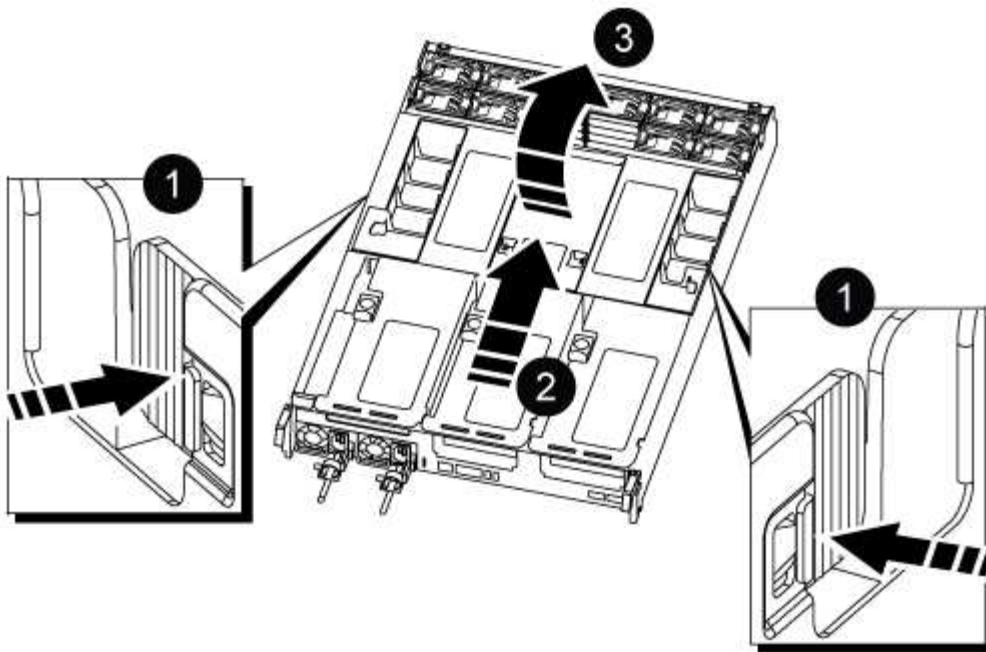

1	Air duct locking tabs
2	Slide air duct towards fan modules
3	Rotate air duct towards fan modules

### Step 2: Move the power supplies

You must move the power supplies from the impaired controller module to the replacement controller module when you replace a controller module.

1. Rotate the cam handle such that it can be used to pull power supply out of the controller module while pressing the locking tab.



The power supply is short. Always use two hands to support it when removing it from the controller module so that it does not suddenly swing free from the controller module and injure you.

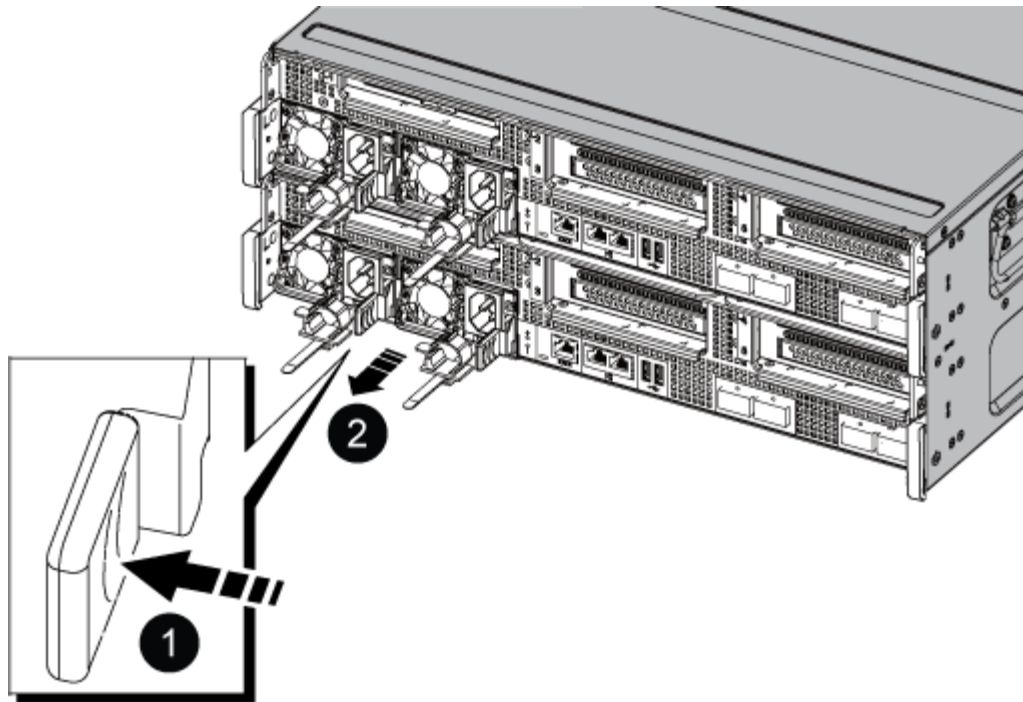

1	Blue power supply locking tab
2	Power supply

2. Move the power supply to the new controller module, and then install it.
3. Using both hands, support and align the edges of the power supply with the opening in the controller module, and then gently push the power supply into the controller module until the locking tab clicks into place.

The power supplies will only properly engage with the internal connector and lock in place one way.



To avoid damaging the internal connector, do not use excessive force when sliding the power supply into the system.

### Step 3: Move the fans

You must move the fans from the impaired controller module to the replacement module when replacing a failed controller module.

1. Remove the fan module by pinching the locking tabs on the side of the fan module, and then lifting the fan module straight out of the controller module.

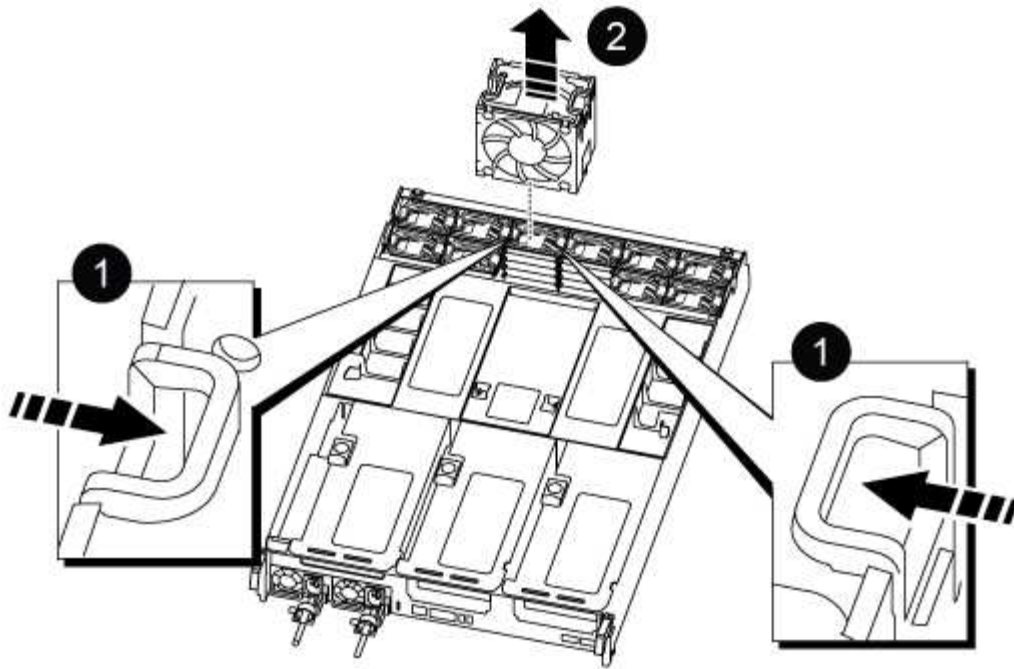

<b>1</b>
Fan locking tabs
<b>2</b>
Fan module

2. Move the fan module to the replacement controller module, and then install the fan module by aligning its edges with the opening in the controller module, and then sliding the fan module into the controller module until the locking latches click into place.
3. Repeat these steps for the remaining fan modules.

#### Step 4: Move the NVDIMM battery

When replacing the controller module, you must move the NVRAM battery from the impaired controller module to the replacement controller module

1. Open the air duct cover and locate the NVDIMM battery in the riser.

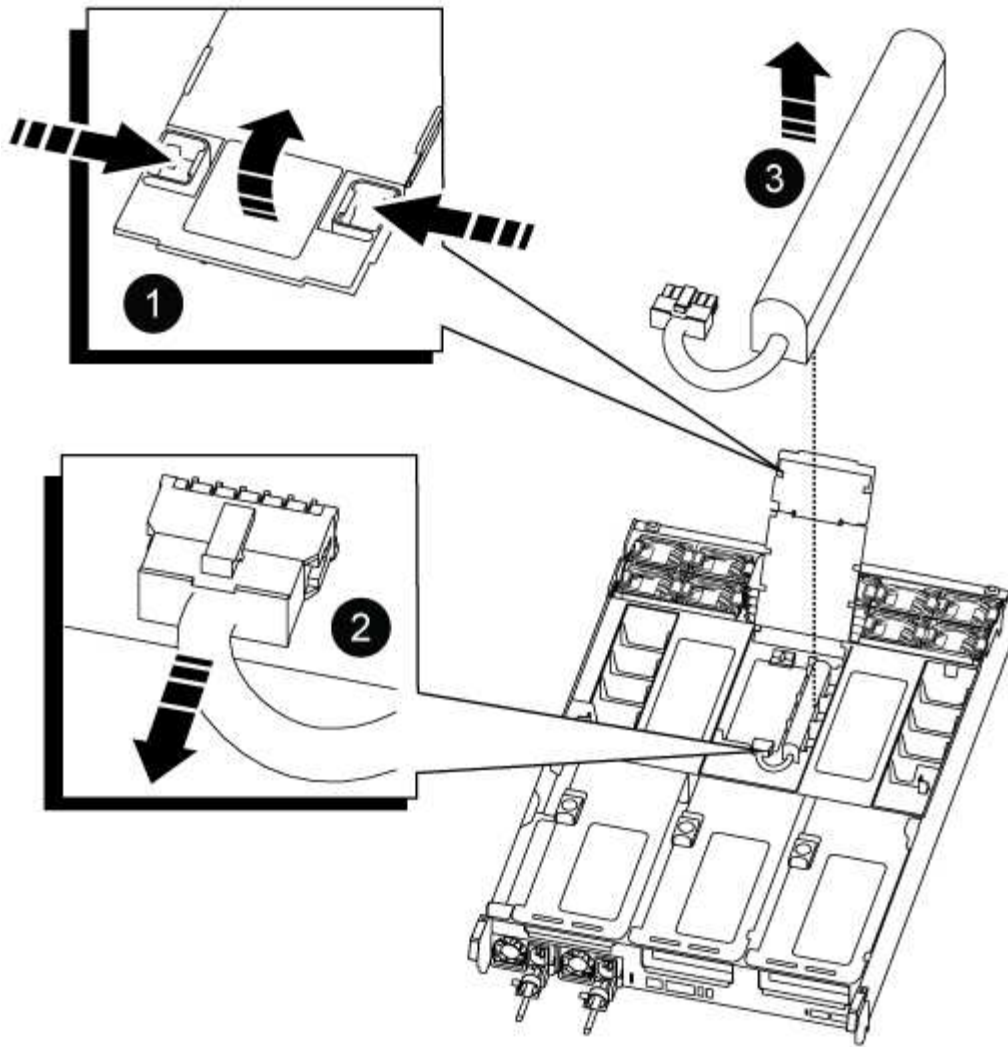

1	Air duct riser
2	NVDIMM battery plug
3	NVDIMM battery pack

**Attention:** The NVDIMM battery control board LED blinks while destaging contents to the flash memory when you halt the system. After the destage is complete, the LED turns off.

2. Locate the battery plug and squeeze the clip on the face of the battery plug to release the plug from the socket, and then unplug the battery cable from the socket.
3. Grasp the battery and lift the battery out of the air duct and controller module.
4. Move the battery pack to the replacement controller module and then install it in the NVDIMM air duct:
  - a. Insert the battery pack into the slot and press firmly down on the battery pack to make sure that it is locked into place.
  - b. Plug the battery plug into the riser socket and make sure that the plug locks into place.



## Step 5: Remove the PCIe risers

As part of the controller replacement process, you must remove the PCIe modules from the impaired controller module. You must install them into the same location in the replacement controller module once the NVDIMMs and DIMMs have moved to the replacement controller module.

1. Remove the PCIe riser from the controller module:
  - a. Remove any SFP or QSFP modules that might be in the PCIe cards.
  - b. Rotate the riser locking latch on the left side of the riser up and toward the fan modules.

The riser raises up slightly from the controller module.

- c. Lift the riser up, shift it toward the fans so that the sheet metal lip on the riser clears the edge of the controller module, lift the riser out of the controller module, and then place it on a stable, flat surface.

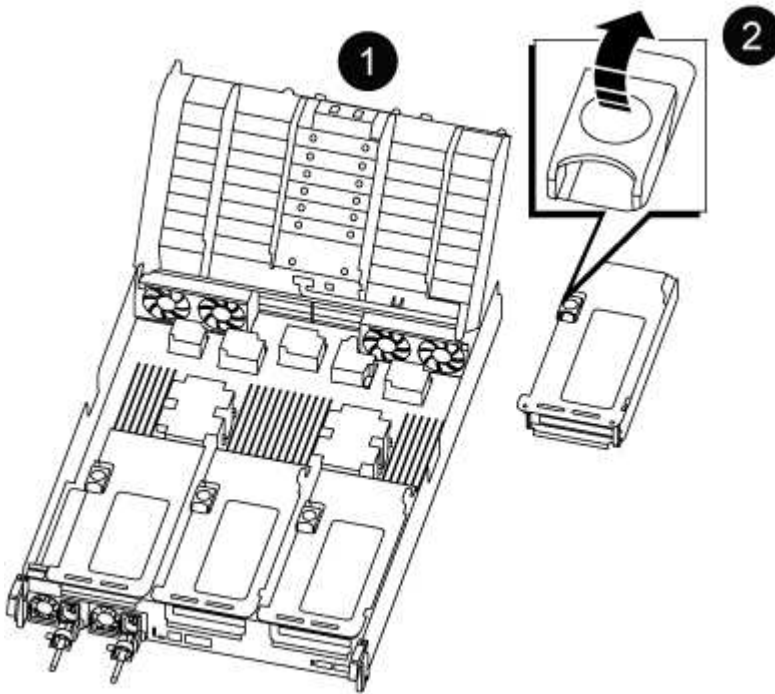

<b>1</b>	Air duct
<b>2</b>	Riser 1 (left riser), Riser 2 (middle riser), and 3 (right riser) locking latches

2. Repeat the preceding step for the remaining risers in the impaired controller module.
3. Repeat the above steps with the empty risers in the replacement controller and put them away.

## Step 6: Move system DIMMs

To move the DIMMs, locate and move them from the impaired controller into the replacement controller and follow the specific sequence of steps.

1. Note the orientation of the DIMM in the socket so that you can insert the DIMM in the replacement controller module in the proper orientation.

- Eject the DIMM from its slot by slowly pushing apart the two DIMM ejector tabs on either side of the DIMM, and then slide the DIMM out of the slot.



Carefully hold the DIMM by the edges to avoid pressure on the components on the DIMM circuit board.

- Locate the slot where you are installing the DIMM.
- Insert the DIMM squarely into the slot.

The DIMM fits tightly in the slot, but should go in easily. If not, realign the DIMM with the slot and reinsert it.



Visually inspect the DIMM to verify that it is evenly aligned and fully inserted into the slot.

- Push carefully, but firmly, on the top edge of the DIMM until the ejector tabs snap into place over the notches at the ends of the DIMM.
- Repeat these steps for the remaining DIMMs.

### Step 7: Move the NVDIMMs

To move the NVDIMMs, locate and move them from the impaired controller into the replacement controller and follow the specific sequence of steps.

- Locate the NVDIMMs on your controller module.

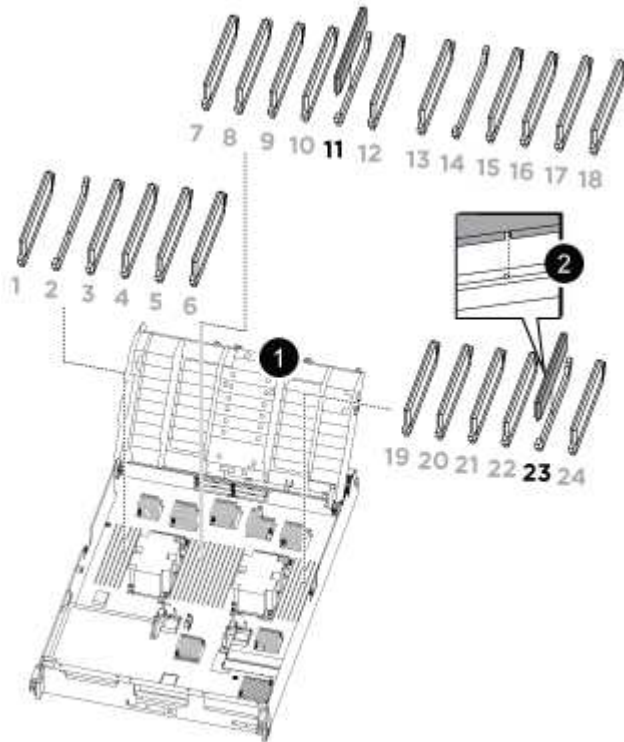

**- NVDIMM: SLOTS 11 & 23**

<b>1</b>	Air duct
----------	----------

2

## NVDIMMs

2. Note the orientation of the NVDIMM in the socket so that you can insert the NVDIMM in the replacement controller module in the proper orientation.
3. Eject the NVDIMM from its slot by slowly pushing apart the two NVDIMM ejector tabs on either side of the NVDIMM, and then slide the NVDIMM out of the socket and set it aside.



Carefully hold the NVDIMM by the edges to avoid pressure on the components on the NVDIMM circuit board.

4. Locate the slot where you are installing the NVDIMM.
5. Insert the NVDIMM squarely into the slot.

The NVDIMM fits tightly in the slot, but should go in easily. If not, realign the NVDIMM with the slot and reinsert it.



Visually inspect the NVDIMM to verify that it is evenly aligned and fully inserted into the slot.

6. Push carefully, but firmly, on the top edge of the NVDIMM until the ejector tabs snap into place over the notches at the ends of the NVDIMM.
7. Repeat the preceding steps to move the other NVDIMM.

### Step 8: Move the boot media

You must move the boot media device from the impaired controller and install it in the replacement controller.

The boot media is located under Riser 3.

1. Locate the boot media:

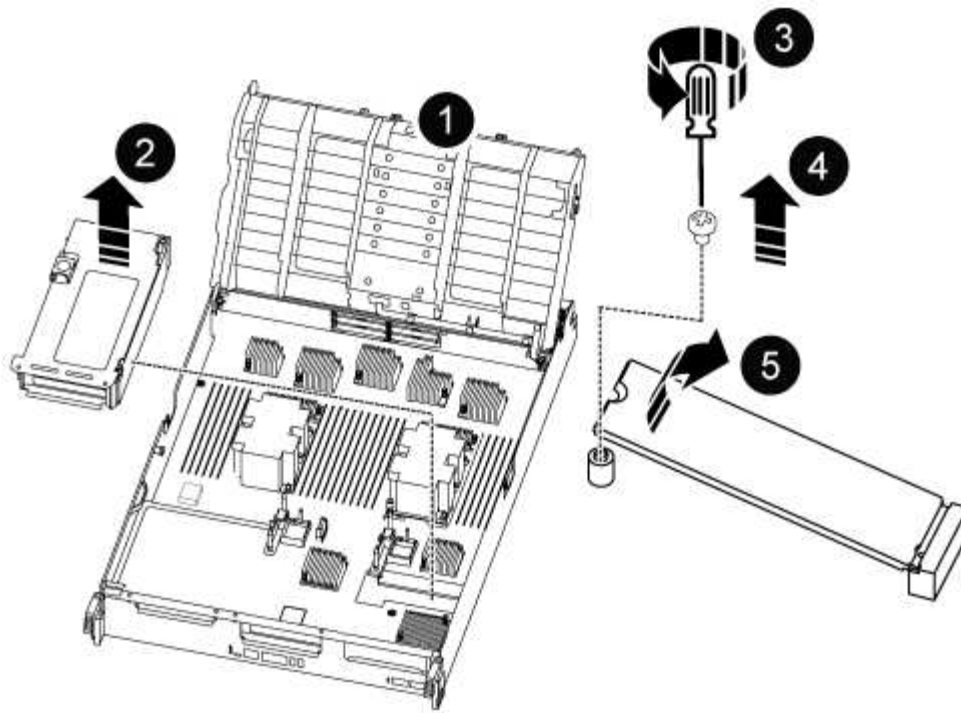

1	Air duct
2	Riser 3
3	Phillips #1 screwdriver
4	Boot media screw
5	Boot media

2. Remove the boot media from the controller module:

- a. Using a #1 Phillips head screwdriver, remove the screw holding down the boot media and set the screw aside in a safe place.
- b. Grasping the sides of the boot media, gently rotate the boot media up, and then pull the boot media straight out of the socket and set it aside.

3. Move the boot media to the new controller module and install it:

- a. Align the edges of the boot media with the socket housing, and then gently push it squarely into the socket.
- b. Rotate the boot media down toward the motherboard.
- c. Secure the boot media to the motherboard using the boot media screw.

Do not over-tighten the screw or you might damage the boot media.

## Step 9: Install the PCIe risers

You install the PCIe risers in the replacement controller module after moving the DIMMs, NVDIMMs, and boot media.

1. Install the riser into the replacement controller module:
  - a. Align the lip of the riser with the underside of the controller module sheet metal.
  - b. Guide the riser along the pins in the controller module, and then lower the riser into the controller module.
  - c. Swing the locking latch down and click it into the locked position.

When locked, the locking latch is flush with the top of the riser and the riser sits squarely in the controller module.

- d. Reinsert any SFP or QSFP modules that were removed from the PCIe cards.
2. Repeat the preceding step for the remaining PCIe risers.

## Step 10: Install the controller module

After all of the components have been moved from the impaired controller module to the replacement controller module, you must install the replacement controller module into the chassis and then boot it to Maintenance mode.

1. If you have not already done so, close the air duct:
  - a. Swing the air duct all the way down to the controller module.
  - b. Slide the air duct toward the risers until the locking tabs click into place.
  - c. Inspect the air duct to make sure that it is properly seated and locked into place.

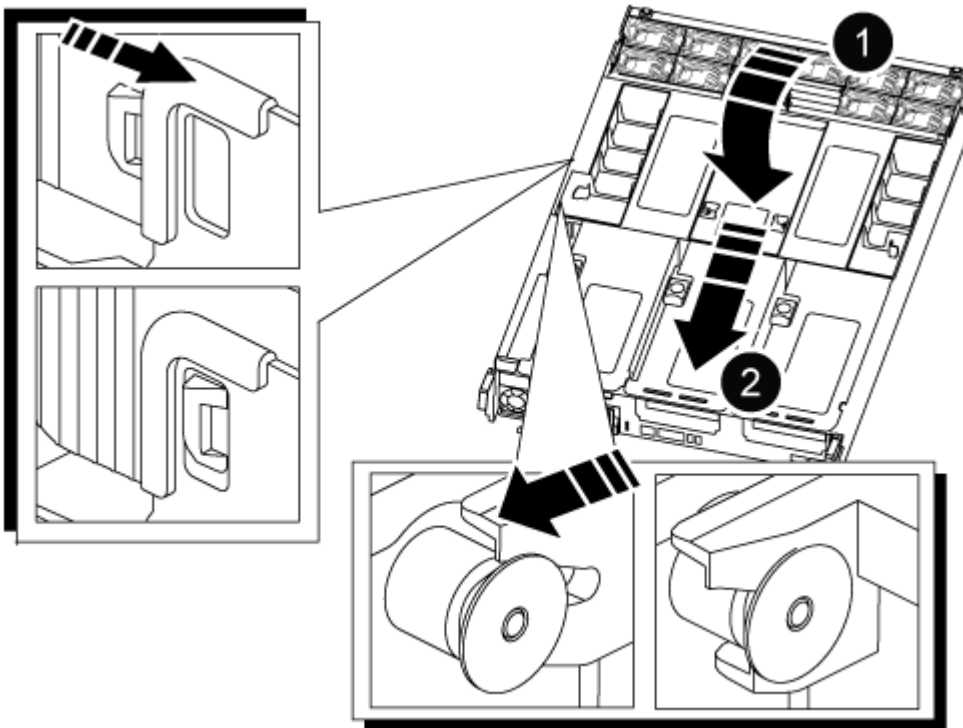

<b>1</b>	Locking tabs
<b>2</b>	Slide plunger

2. Align the end of the controller module with the opening in the chassis, and then gently push the controller module halfway into the system.



Do not completely insert the controller module in the chassis until instructed to do so.

3. Cable the management and console ports only, so that you can access the system to perform the tasks in the following sections.



You will connect the rest of the cables to the controller module later in this procedure.

4. Complete the reinstallation of the controller module:

a. Firmly push the controller module into the chassis until it meets the midplane and is fully seated.

The locking latches rise when the controller module is fully seated.



Do not use excessive force when sliding the controller module into the chassis to avoid damaging the connectors.

b. Rotate the locking latches upward, tilting them so that they clear the locking pins, and then lower them into the locked position.

5. Plug the system cables and transceiver modules into the controller module and reinstall the cable management device.

6. Plug the power cables into the power supplies and reinstall the power cable retainers.

The controller module begins to boot as soon as it is connected to power. Be prepared to interrupt the boot process.



If your system has DC power supplies, make sure the thumbscrews on the power supply cable are tight.

## Restore and verify the system configuration - ASA C800

After completing the hardware replacement and booting to Maintenance mode, you verify the low-level system configuration of the replacement controller and reconfigure system settings as necessary.

### Step 1: Set and verify system time

You should check the time and date on the replacement controller module against the healthy controller module in an HA pair, or against a reliable time server in a stand-alone configuration. If the time and date do not match, you must reset them on the replacement controller module to prevent possible outages on clients due to time differences.

## About this task

It is important that you apply the commands in the steps on the correct systems:

- The *replacement* node is the new node that replaced the impaired node as part of this procedure.
- The *healthy* node is the HA partner of the *replacement* node.

## Steps

1. If the *replacement* node is not at the LOADER prompt, halt the system to the LOADER prompt.
2. On the *healthy* node, check the system time: `cluster date show`

The date and time are based on the configured timezone.

3. At the LOADER prompt, check the date and time on the *replacement* node: `show date`

The date and time are given in GMT.

4. If necessary, set the date in GMT on the replacement node: `set date mm/dd/yyyy`

5. If necessary, set the time in GMT on the replacement node: `set time hh:mm:ss`

6. At the LOADER prompt, confirm the date and time on the *replacement* node: `show date`

The date and time are given in GMT.

## Step 2: Verify and set the HA state of the chassis

You must verify the HA state of the controller module and, if necessary, update the state to match your system configuration.

1. In Maintenance mode from the new controller module, verify that all components display the same HA state: `ha-config show`

The HA state should be the same for all components.

2. If the displayed system state of the controller module does not match your system configuration, set the HA state for the controller module: `ha-config modify controller ha-state`

The value for HA-state can be one of the following:

- `ha`
- `mcc`
- `mccip`
- `non-ha`

3. If the displayed system state of the controller module does not match your system configuration, set the HA state for the controller module: `ha-config modify controller ha-state`

4. Confirm that the setting has changed: `ha-config show`

## Recable the system and reassign disks - ASA C800

Continue the replacement procedure by recabling the storage and confirming disk reassignment.

### Step 1: Recable the system

Recable the controller module's storage and network connections.

#### Steps

1. Recable the the controller module to storage and network connections.
2. Verify that the cabling is correct by using [Active IQ Config Advisor](#).
  - a. Download and install Config Advisor.
  - b. Enter the information for the target system, and then click Collect Data.
  - c. Click the Cabling tab, and then examine the output. Make sure that all disk shelves are displayed and all disks appear in the output, correcting any cabling issues you find.
  - d. Check other cabling by clicking the appropriate tab, and then examining the output from Config Advisor.

### Step 2: Reassign disks

If the storage system is in an HA pair, the system ID of the new controller module is automatically assigned to the disks when the giveback occurs at the end of the procedure. You must confirm the system ID change when you boot the *replacement* controller and then verify that the change was implemented.

This procedure applies only to systems running ONTAP in an HA pair.

1. If the *replacement* controller is in Maintenance mode (showing the `*>` prompt, exit Maintenance mode and go to the LOADER prompt: `halt`
2. From the LOADER prompt on the *replacement* controller, boot the controller, entering `y` if you are prompted to override the system ID due to a system ID mismatch: `boot_ontap`
3. Wait until the `Waiting for giveback...` message is displayed on the *replacement* controller console and then, from the healthy controller, verify that the new partner system ID has been automatically assigned:  
`storage failover show`

In the command output, you should see a message that the system ID has changed on the impaired controller, showing the correct old and new IDs. In the following example, node2 has undergone replacement and has a new system ID of 151759706.



```

node1> `storage failover show`

```

Node	Partner	Takeover Possible	State Description
node1	node2	false	System ID changed on partner (Old: 151759706), In takeover 151759755, New: 151759706)
node2	node1	-	Waiting for giveback (HA mailboxes)

4. From the healthy controller, verify that any coredumps are saved:

- a. Change to the advanced privilege level: `set -privilege advanced`

You can respond `y` when prompted to continue into advanced mode. The advanced mode prompt appears (`*>`).

- b. Save any coredumps: `system node run -node local-node-name partner savecore`

- c. Wait for the `savecore` command to complete before issuing the giveback.

You can enter the following command to monitor the progress of the `savecore` command: `system node run -node local-node-name partner savecore -s`

- d. Return to the admin privilege level: `set -privilege admin`

5. If your storage system has Storage or Volume Encryption configured, you must restore Storage or Volume Encryption functionality by using one of the following procedures, depending on whether you are using onboard or external key management:

- [Restore onboard key management encryption keys](#)
- [Restore external key management encryption keys](#)

6. Give back the controller:

- a. From the healthy controller, give back the replaced controller's storage: `storage failover giveback -ofnode replacement_node_name`

The *replacement* controller takes back its storage and completes booting.

If you are prompted to override the system ID due to a system ID mismatch, you should enter `y`.



If the giveback is vetoed, you can consider overriding the vetoes.

[Find the High-Availability Configuration content for your version of ONTAP 9](#)

- b. After the giveback has been completed, confirm that the HA pair is healthy and that takeover is possible: `storage failover show`

The output from the `storage failover show` command should not include the System ID changed

on partner message.

7. Verify that the disks were assigned correctly: `storage disk show -ownership`

The disks belonging to the *replacement* controller should show the new system ID. In the following example, the disks owned by node1 now show the new system ID, 1873775277:

```
node1> `storage disk show -ownership`

Disk Aggregate Home  Owner  DR Home  Home ID      Owner ID  DR Home ID
Reserver  Pool
-----  -----  -----  -----  -----  -----  -----
-----  ---
1.0.0   aggr0_1  node1  node1  -           1873775277 1873775277  -
1873775277 Pool10
1.0.1   aggr0_1  node1  node1           1873775277 1873775277  -
1873775277 Pool10
.
.
.
```

8. If the system is in a MetroCluster configuration, monitor the status of the controller: `metrocluster node show`

The MetroCluster configuration takes a few minutes after the replacement to return to a normal state, at which time each controller will show a configured state, with DR Mirroring enabled and a mode of normal. The `metrocluster node show -fields node-systemid` command output displays the old system ID until the MetroCluster configuration returns to a normal state.

9. If the controller is in a MetroCluster configuration, depending on the MetroCluster state, verify that the DR home ID field shows the original owner of the disk if the original owner is a controller on the disaster site.

This is required if both of the following are true:

- The MetroCluster configuration is in a switchover state.
- The *replacement* controller is the current owner of the disks on the disaster site.

[Disk ownership changes during HA takeover and MetroCluster switchover in a four-node MetroCluster configuration](#)

10. If your system is in a MetroCluster configuration, verify that each controller is configured: `metrocluster node show - fields configuration-state`

```

node1_siteA::> metrocluster node show -fields configuration-state

dr-group-id          cluster node          configuration-state
-----
-----
1 node1_siteA        node1mcc-001         configured
1 node1_siteA        node1mcc-002         configured
1 node1_siteB        node1mcc-003         configured
1 node1_siteB        node1mcc-004         configured

4 entries were displayed.

```

11. Verify that the expected volumes are present for each controller: `vol show -node node-name`
12. If you disabled automatic takeover on reboot, enable it from the healthy controller: `storage failover modify -node replacement-node-name -onreboot true`

### Complete system restoration - ASA C800

To restore your system to full operation, you must restore the NetApp Storage Encryption configuration (if necessary), and install licenses for the new controller, and return the failed part to NetApp, as described in the RMA instructions shipped with the kit.

#### Step 1: Install licenses for the replacement controller in ONTAP

You must install new licenses for the *replacement* node if the impaired node was using ONTAP features that require a standard (node-locked) license. For features with standard licenses, each node in the cluster should have its own key for the feature.

#### About this task

Until you install license keys, features requiring standard licenses continue to be available to the *replacement* node. However, if the impaired node was the only node in the cluster with a license for the feature, no configuration changes to the feature are allowed. Also, using unlicensed features on the node might put you out of compliance with your license agreement, so you should install the replacement license key or keys on the *replacement* node as soon as possible.

#### Before you begin

The licenses keys must be in the 28-character format.

You have a 90-day grace period in which to install the license keys. After the grace period, all old licenses are invalidated. After a valid license key is installed, you have 24 hours to install all of the keys before the grace period ends.

#### Steps

1. If you need new license keys, obtain replacement license keys on the [NetApp Support Site](#) in the My Support section under Software licenses.



The new license keys that you require are automatically generated and sent to the email address on file. If you fail to receive the email with the license keys within 30 days, you should contact technical support.

2. Install each license key: `system license add -license-code license-key, license-key...`
3. Remove the old licenses, if desired:
  - a. Check for unused licenses: `license clean-up -unused -simulate`
  - b. If the list looks correct, remove the unused licenses: `license clean-up -unused`

## Step 2: Verify LIFs and registering the serial number

Before returning the *replacement* node to service, you should verify that the LIFs are on their home ports, and register the serial number of the *replacement* node if AutoSupport is enabled, and reset automatic giveback.

### Steps

1. Verify that the logical interfaces are reporting to their home server and ports: `network interface show -is-home false`  
  
If any LIFs are listed as false, revert them to their home ports: `network interface revert -vserver * -lif *`
2. Register the system serial number with NetApp Support.
  - If AutoSupport is enabled, send an AutoSupport message to register the serial number.
  - If AutoSupport is not enabled, call [NetApp Support](#) to register the serial number.
3. If an AutoSupport maintenance window was triggered, end it by using the `system node autosupport invoke -node * -type all -message MAINT=END` command.
4. If automatic giveback was disabled, reenabling it: `storage failover modify -node local -auto-giveback true`

## Step 3: Return the failed part to NetApp

Return the failed part to NetApp, as described in the RMA instructions shipped with the kit. See the [Part Return and Replacements](#) page for further information.

### Replace a DIMM - ASA C800

You must replace a DIMM in the controller module when your system registers an increasing number of correctable error correction codes (ECC); failure to do so causes a system panic.

All other components in the system must be functioning properly; if not, you must contact technical support.

You must replace the failed component with a replacement FRU component you received from your provider.

### Step 1: Shut down the impaired controller

Recable the controller module's storage and network connections.

### Steps

1. Recable the the controller module to storage and network connections.
2. Verify that the cabling is correct by using [Active IQ Config Advisor](#).
  - a. Download and install Config Advisor.
  - b. Enter the information for the target system, and then click Collect Data.
  - c. Click the Cabling tab, and then examine the output. Make sure that all disk shelves are displayed and all disks appear in the output, correcting any cabling issues you find.
  - d. Check other cabling by clicking the appropriate tab, and then examining the output from Config Advisor.

## Step 2: Remove the controller module

You must remove the controller module from the chassis when you replace the controller module or replace a component inside the controller module.

1. If you are not already grounded, properly ground yourself.
2. Unplug the controller module power supplies from the source.
3. Release the power cable retainers, and then unplug the cables from the power supplies.
4. Loosen the hook and loop strap binding the cables to the cable management device, and then unplug the system cables and SFP and QSFP modules (if needed) from the controller module, keeping track of where the cables were connected.

Leave the cables in the cable management device so that when you reinstall the cable management device, the cables are organized.

5. Remove the cable management device from the controller module and set it aside.
6. Press down on both of the locking latches, and then rotate both latches downward at the same time.

The controller module moves slightly out of the chassis.

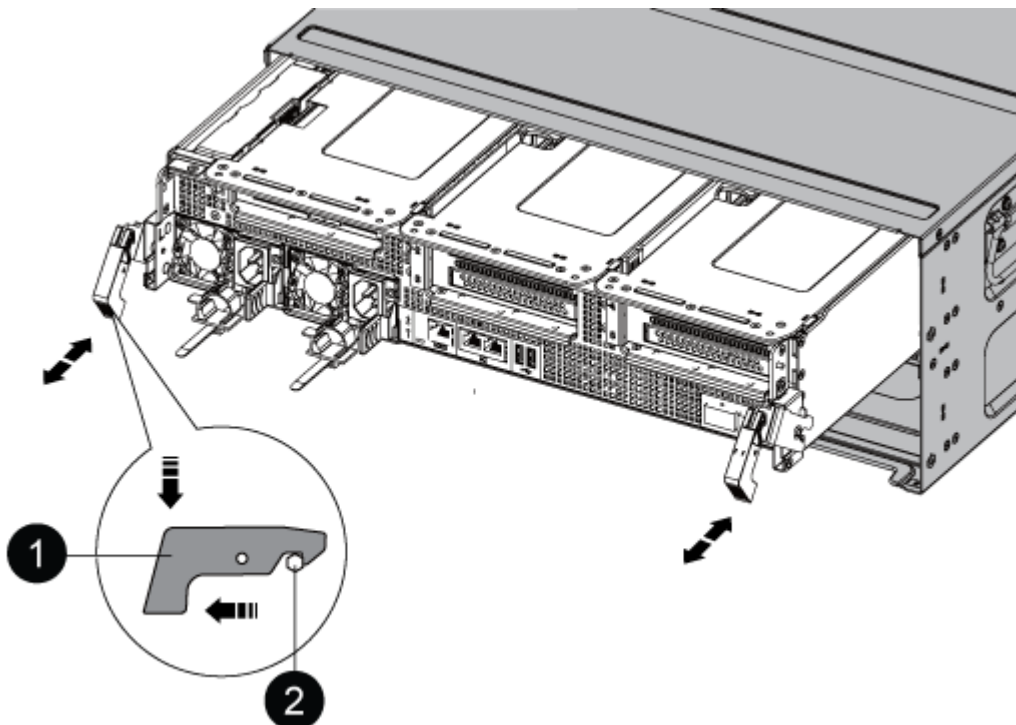

1	Locking latch
2	Locking pin

7. Slide the controller module out of the chassis.

Make sure that you support the bottom of the controller module as you slide it out of the chassis.

8. Place the controller module on a stable, flat surface, and then open the air duct:

- a. Press in the locking tabs on the sides of the air duct toward the middle of the controller module.
- b. Slide the air duct toward the fan modules, and then rotate it upward to its completely open position.

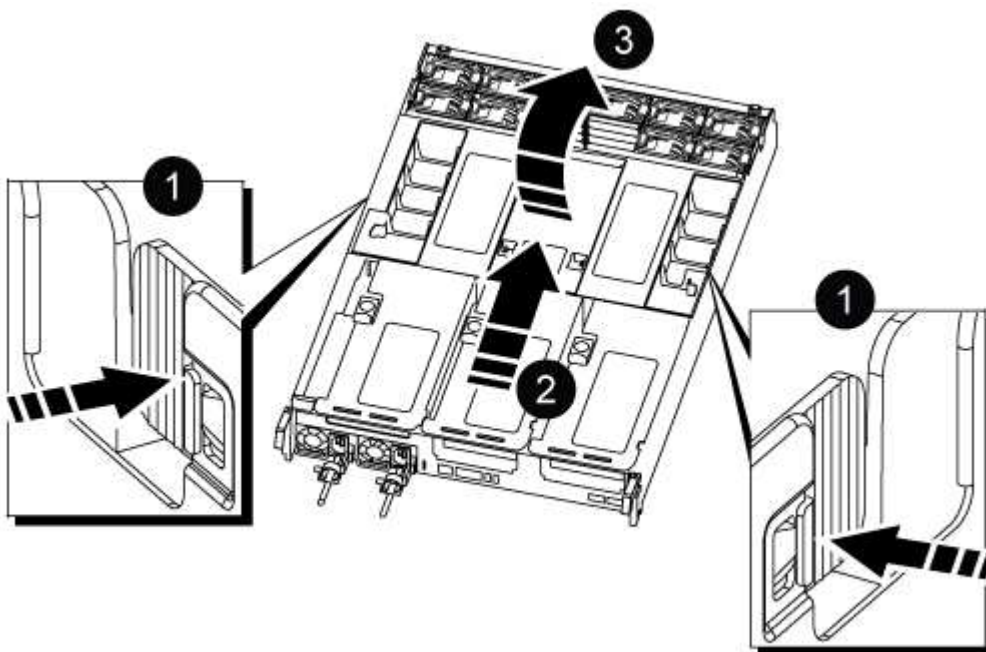

1	Air duct locking tabs
2	Slide air duct towards fan modules
3	Rotate air duct towards fan modules

### Step 3: Replace a DIMM

To replace a DIMM, you must locate it in the controller module using the DIMM map label on top of the air duct and then replace it following the specific sequence of steps.

1. When removing a DIMM, unlock the locking latch on the applicable riser, and then remove the riser.

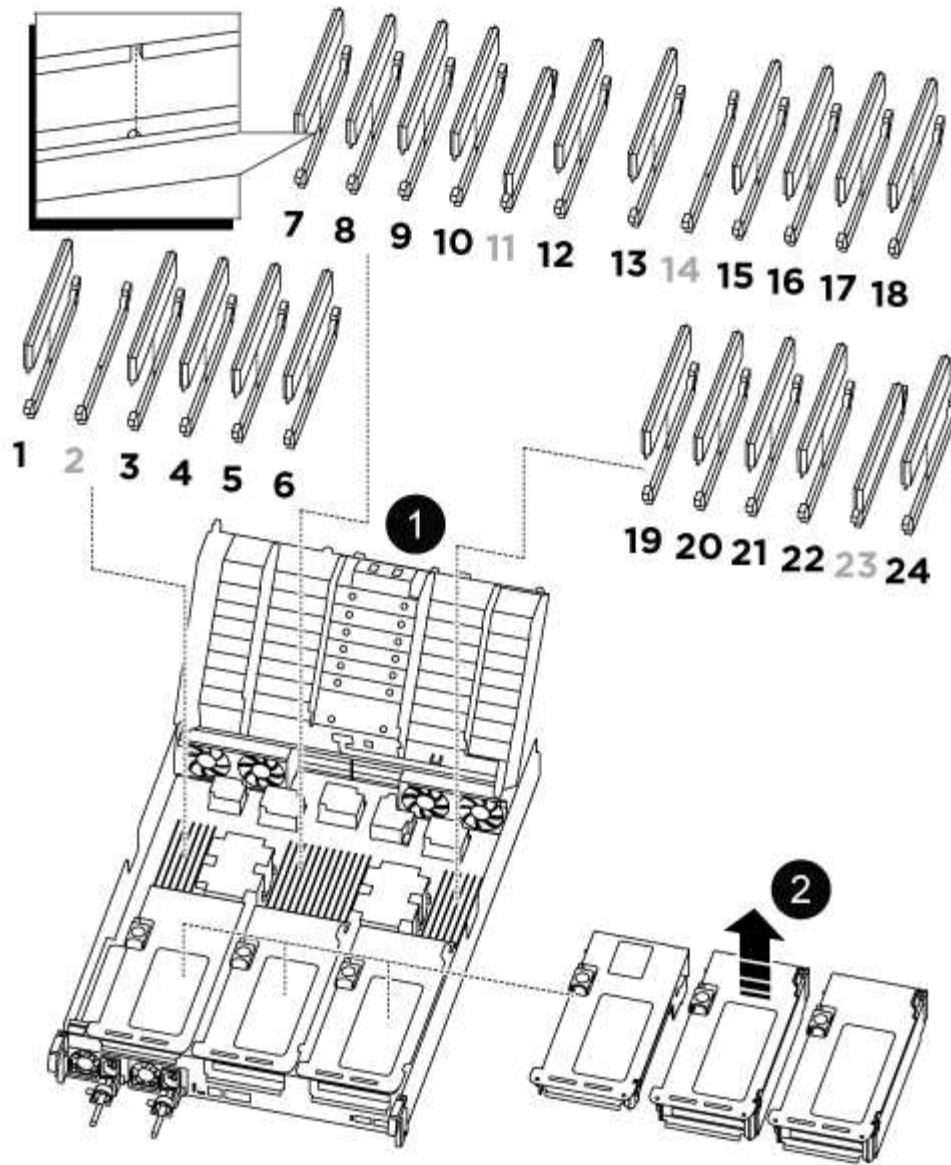

<p>1</p>	<p>Air duct cover</p>
<p>2</p>	<p>Riser 1 and DIMM bank 1, and 3-6</p>
<p>Riser 2 and DIMM bank 7-10, 12-13, and 15-18</p>	<p>Riser 3 and DIMM 19 -22 and 24</p>

**Note:** Slot 2 and 14 are left empty. Do not attempt to install DIMMs into these slots.

2. Note the orientation of the DIMM in the socket so that you can insert the replacement DIMM in the proper orientation.
3. Eject the DIMM from its slot by slowly pushing apart the two DIMM ejector tabs on either side of the DIMM, and then slide the DIMM out of the slot.



Carefully hold the DIMM by the edges to avoid pressure on the components on the DIMM circuit board.

4. Remove the replacement DIMM from the antistatic shipping bag, hold the DIMM by the corners, and align it to the slot.

The notch among the pins on the DIMM should line up with the tab in the socket.

5. Insert the DIMM squarely into the slot.

The DIMM fits tightly in the slot, but should go in easily. If not, realign the DIMM with the slot and reinsert it.



Visually inspect the DIMM to verify that it is evenly aligned and fully inserted into the slot.

6. Push carefully, but firmly, on the top edge of the DIMM until the ejector tabs snap into place over the notches at the ends of the DIMM.
7. Reinstall any risers that you removed from the controller module.
8. Close the air duct.

#### Step 4: Reinstall the controller module and booting the system

After you replace a FRU in the controller module, you must reinstall the controller module and reboot it.

1. If you have not already done so, close the air duct:
  - a. Swing the air duct all the way down to the controller module.
  - b. Slide the air duct toward the risers until the locking tabs click into place.
  - c. Inspect the air duct to make sure that it is properly seated and locked into place.

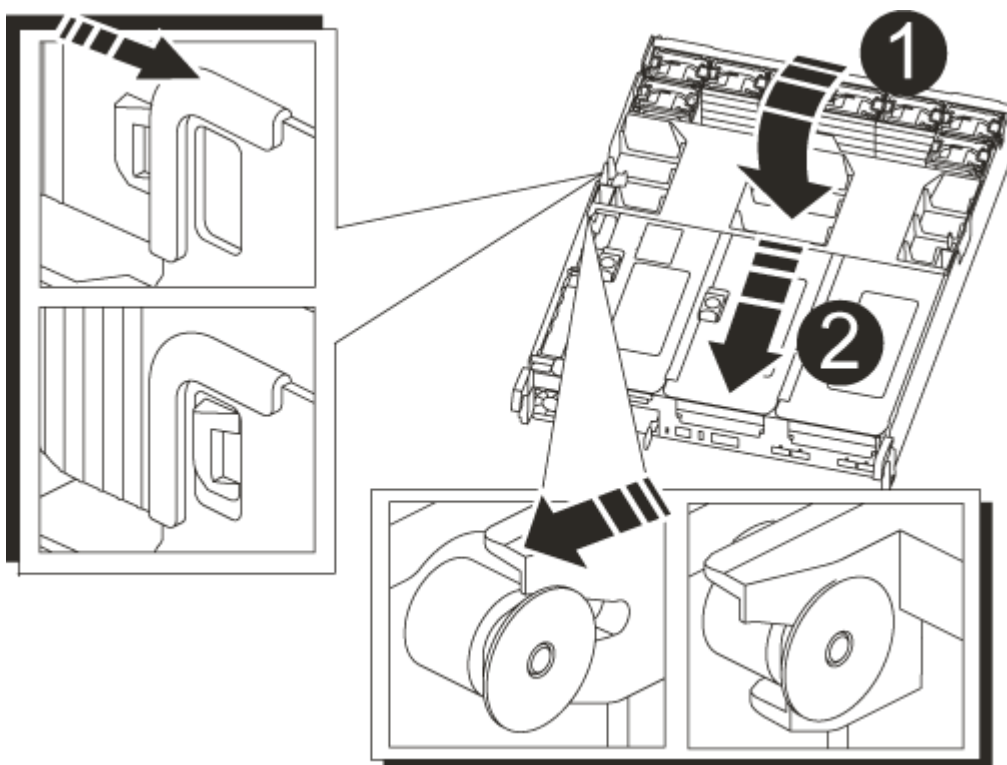



<b>1</b>	Locking tabs
<b>2</b>	Slide plunger

2. Align the end of the controller module with the opening in the chassis, and then gently push the controller module halfway into the system.



Do not completely insert the controller module in the chassis until instructed to do so.

3. Recable the system, as needed.

If you removed the media converters (QSFPs or SFPs), remember to reinstall them if you are using fiber optic cables.

4. Plug the power cord into the power supply, reinstall the power cable locking collar, and then connect the power supply to the power source.
5. Complete the reinstallation of the controller module:
  - a. Firmly push the controller module into the chassis until it meets the midplane and is fully seated.

The locking latches rise when the controller module is fully seated.



Do not use excessive force when sliding the controller module into the chassis to avoid damaging the connectors.

The controller module begins to boot as soon as it is fully seated in the chassis.

- b. Rotate the locking latches upward, tilting them so that they clear the locking pins, and then lower them into the locked position.
- c. If you have not already done so, reinstall the cable management device.

### Step 5: Return the failed part to NetApp

Return the failed part to NetApp, as described in the RMA instructions shipped with the kit. See the [Part Return and Replacements](#) page for further information.

#### Replace SSD Drive or HDD Drive - ASA C800

You can replace a failed drive nondisruptively while I/O is in progress. The procedure for replacing an SSD is meant for non-spinning drives and the procedure for replacing an HDD is meant for spinning drives.

When a drive fails, the platform logs a warning message to the system console indicating which drive has failed. In addition, both the fault LED on the operator display panel and the fault LED on the failed drive are illuminated.

#### Before you begin

- Follow best practice and install the current version of the Disk Qualification Package (DQP) before replacing a drive.

- Identify the failed drive by running the `storage disk show -broken` command from the system console.

The failed drive appears in the list of failed drives. If it does not, you should wait, and then run the command again.



Depending on the type and capacity, it can take up to several hours for the drive to appear in the list of failed drives.

- Determine whether SED authentication is enabled.

How you replace the drive depends on how the drive is being used. If SED authentication is enabled, you must use the SED replacement instructions in the [ONTAP 9 NetApp Encryption Power Guide](#). These Instructions describe additional steps you must perform before and after replacing an SED.

- Make sure the replacement drive is supported by your platform. See the [NetApp Hardware Universe](#).
- Make sure all other components in the system are functioning properly; if not, you must contact technical support.

#### **About this task**

- Drive firmware is automatically updated (nondisruptively) on new drives that have non current firmware versions.
- When replacing a drive, you must wait one minute between the removal of the failed drive and the insertion of the replacement drive to allow the storage system to recognize the existence of the new drive.

## Option 1: Replace SSD

### Steps

1. If you want to manually assign drive ownership for the replacement drive, you need to disable automatic drive assignment replacement drive, if it is enabled



You manually assign drive ownership and then reenable automatic drive assignment later in this procedure.

- a. Verify whether automatic drive assignment is enabled: `storage disk option show`

You can enter the command on either controller module.

If automatic drive assignment is enabled, the output shows `on` in the “Auto Assign” column (for each controller module).

- b. If automatic drive assignment is enabled, disable it: `storage disk option modify -node node_name -autoassign off`

You must disable automatic drive assignment on both controller modules.

2. Properly ground yourself.
3. Physically identify the failed drive.

When a drive fails, the system logs a warning message to the system console indicating which drive failed. Additionally, the attention (amber) LED on the drive shelf operator display panel and the failed drive illuminate.



The activity (green) LED on a failed drive can be illuminated (solid), which indicates that the drive has power, but should not be blinking, which indicates I/O activity. A failed drive has no I/O activity.

4. Remove the failed drive:
  - a. Press the release button on the drive face to open the cam handle.
  - b. Slide the drive out of the shelf using the cam handle and supporting the drive with your other hand.

5. Wait a minimum of 70 seconds before inserting the replacement drive.

This allows the system to recognize that a drive was removed.

6. Insert the replacement drive:
  - a. With the cam handle in the open position, use both hands to insert the replacement drive.
  - b. Push until the drive stops.
  - c. Close the cam handle so that the drive is fully seated into the midplane and the handle clicks into place.

Be sure to close the cam handle slowly so that it aligns correctly with the face of the drive.

7. Verify that the drive’s activity (green) LED is illuminated.

When the drive's activity LED is solid, it means that the drive has power. When the drive's activity LED is blinking, it means that the drive has power and I/O is in progress. If the drive firmware is automatically updating, the LED blinks.

8. If you are replacing another drive, repeat Steps 3 through 7.
9. If you disabled automatic drive assignment in Step 1, then, manually assign drive ownership and then reenables automatic drive assignment if needed.

- a. Display all unowned drives: `storage disk show -container-type unassigned`

You can enter the command on either controller module.

- b. Assign each drive: `storage disk assign -disk disk_name -owner node_name`

You can enter the command on either controller module.

You can use the wildcard character to assign more than one drive at once.

- c. Reenable automatic drive assignment if needed: `storage disk option modify -node node_name -autoassign on`

You must reenables automatic drive assignment on both controller modules.

10. Return the failed part to NetApp, as described in the RMA instructions shipped with the kit.

Contact technical support at [NetApp Support](#), 888-463-8277 (North America), 00-800-44-638277 (Europe), or +800-800-80-800 (Asia/Pacific) if you need the RMA number or additional help with the replacement procedure.

## Option 2: Replace HDD

1. If you want to manually assign drive ownership for the replacement drive, you need to disable automatic drive assignment replacement drive, if it is enabled



You manually assign drive ownership and then reenables automatic drive assignment later in this procedure.

- a. Verify whether automatic drive assignment is enabled: `storage disk option show`

You can enter the command on either controller module.

If automatic drive assignment is enabled, the output shows `on` in the "Auto Assign" column (for each controller module).

- b. If automatic drive assignment is enabled, disable it: `storage disk option modify -node node_name -autoassign off`

You must disable automatic drive assignment on both controller modules.

2. Properly ground yourself.
3. Gently remove the bezel from the front of the platform.
4. Identify the failed disk drive from the system console warning message and the illuminated fault LED on the disk drive

5. Press the release button on the disk drive face.

Depending on the storage system, the disk drives have the release button located at the top or on the left of the disk drive face.

For example, the following illustration shows a disk drive with the release button located on the top of the disk drive face:

The cam handle on the disk drive springs open partially and the disk drive releases from the midplane.

6. Pull the cam handle to its fully open position to unseat the disk drive from the midplane.

7. Slide out the disk drive slightly and allow the disk to safely spin down, which can take less than one minute, and then, using both hands, remove the disk drive from the disk shelf.

8. With the cam handle in the open position, insert the replacement disk drive into the drive bay, firmly pushing until the disk drive stops.



Wait a minimum of 10 seconds before inserting a new disk drive. This allows the system to recognize that a disk drive was removed.



If your platform drive bays are not fully loaded with drives, it is important to place the replacement drive into the same drive bay from which you removed the failed drive.



Use two hands when inserting the disk drive, but do not place hands on the disk drive boards that are exposed on the underside of the disk carrier.

9. Close the cam handle so that the disk drive is fully seated into the midplane and the handle clicks into place.

Be sure to close the cam handle slowly so that it aligns correctly with the face of the disk drive..

10. If you are replacing another disk drive, repeat Steps 4 through 9.

11. Reinstall the bezel.

12. If you disabled automatic drive assignment in Step 1, then, manually assign drive ownership and then reenables automatic drive assignment if needed.

a. Display all unowned drives: `storage disk show -container-type unassigned`

You can enter the command on either controller module.

b. Assign each drive: `storage disk assign -disk disk_name -owner owner_name`

You can enter the command on either controller module.

You can use the wildcard character to assign more than one drive at once.

c. Reenable automatic drive assignment if needed: `storage disk option modify -node node_name -autoassign on`

You must reenable automatic drive assignment on both controller modules.

13. Return the failed part to NetApp, as described in the RMA instructions shipped with the kit.

Contact technical support at [NetApp Support](#), 888-463-8277 (North America), 00-800-44-638277 (Europe), or +800-800-80-800 (Asia/Pacific) if you need the RMA number or additional help with the replacement procedure.

## Replace a fan - ASA C800

To replace a fan, remove the failed fan module and replace it with a new fan module.

### Step 1: Shut down the impaired controller

To shut down the impaired controller, you must determine the status of the controller and, if necessary, take over the controller so that the healthy controller continues to serve data from the impaired controller storage.

#### About this task

- If you have a SAN system, you must have checked event messages (`cluster kernel-service show`) for the impaired controller SCSI blade. The `cluster kernel-service show` command (from `priv advanced` mode) displays the node name, quorum status of that node, availability status of that node, and operational status of that node.

Each SCSI-blade process should be in quorum with the other nodes in the cluster. Any issues must be resolved before you proceed with the replacement.

- If you have a cluster with more than two nodes, it must be in quorum. If the cluster is not in quorum or a healthy controller shows `false` for eligibility and health, you must correct the issue before shutting down the impaired controller; see [Synchronize a node with the cluster](#).

#### Steps

1. If AutoSupport is enabled, suppress automatic case creation by invoking an AutoSupport message:  

```
system node autosupport invoke -node * -type all -message MAINT=<# of hours>h
```

The following AutoSupport message suppresses automatic case creation for two hours: `cluster1:>`  

```
system node autosupport invoke -node * -type all -message MAINT=2h
```

2. Disable automatic giveback from the console of the healthy controller: 

```
storage failover modify -node local -auto-giveback false
```



When you see *Do you want to disable auto-giveback?*, enter `y`.

3. Take the impaired controller to the LOADER prompt:

If the impaired controller is displaying...	Then...
The LOADER prompt	Go to the next step.
Waiting for giveback...	Press Ctrl-C, and then respond <code>y</code> when prompted.

If the impaired controller is displaying...	Then...
System prompt or password prompt	<p>Take over or halt the impaired controller from the healthy controller:  <code>storage failover takeover -ofnode <i>impaired_node_name</i></code></p> <p>When the impaired controller shows Waiting for giveback..., press Ctrl-C, and then respond <i>y</i>.</p>

## Step 2: Remove the controller module

You must remove the controller module from the chassis when you replace a fan module.

1. If you are not already grounded, properly ground yourself.
2. Unplug the controller module power supplies from the source.
3. Release the power cable retainers, and then unplug the cables from the power supplies.
4. Loosen the hook and loop strap binding the cables to the cable management device, and then unplug the system cables from the controller module, keeping track of where the cables were connected.

Leave the cables in the cable management device so that when you reinstall the cable management device, the cables are organized.

5. Remove the cable management device from the controller module and set it aside.
6. Press down on both of the locking latches, and then rotate both latches downward at the same time.

The controller module moves slightly out of the chassis.

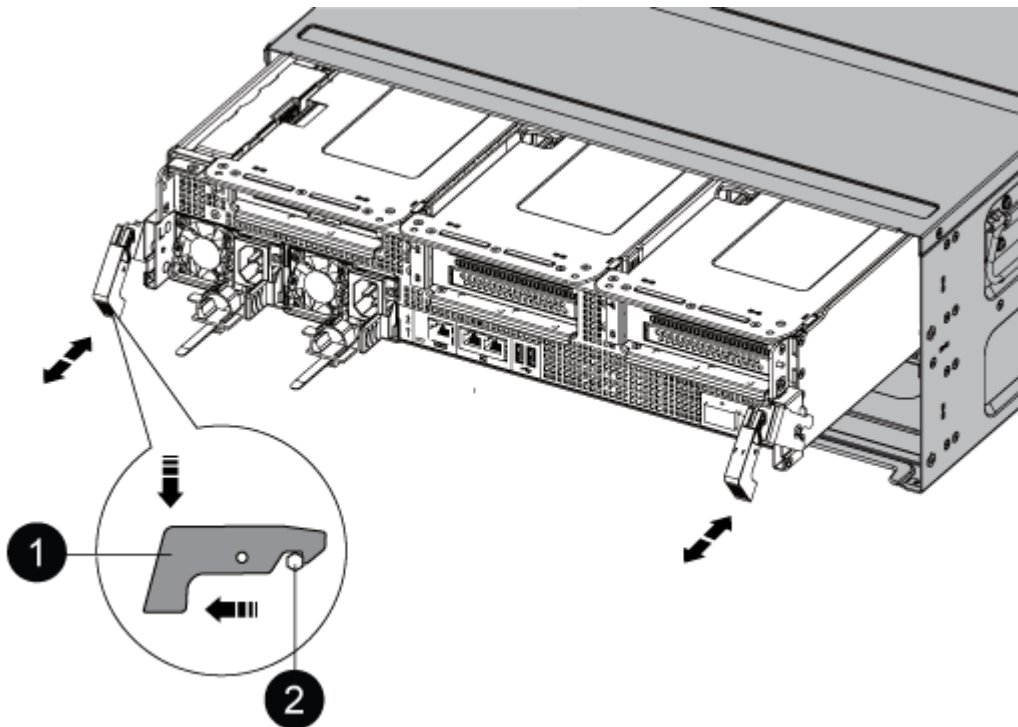

1	Locking latch
2	Locking pin

7. Slide the controller module out of the chassis.

Make sure that you support the bottom of the controller module as you slide it out of the chassis.

8. Set the controller module aside in a safe place.

### Step 3: Replace a fan

To replace a fan, remove the failed fan module and replace it with a new fan module.

1. Identify the fan module that you must replace by checking the console error messages or by locating the lit LED for the fan module on the motherboard.
2. Remove the fan module by pinching the locking tabs on the side of the fan module, and then lifting the fan module straight out of the controller module.

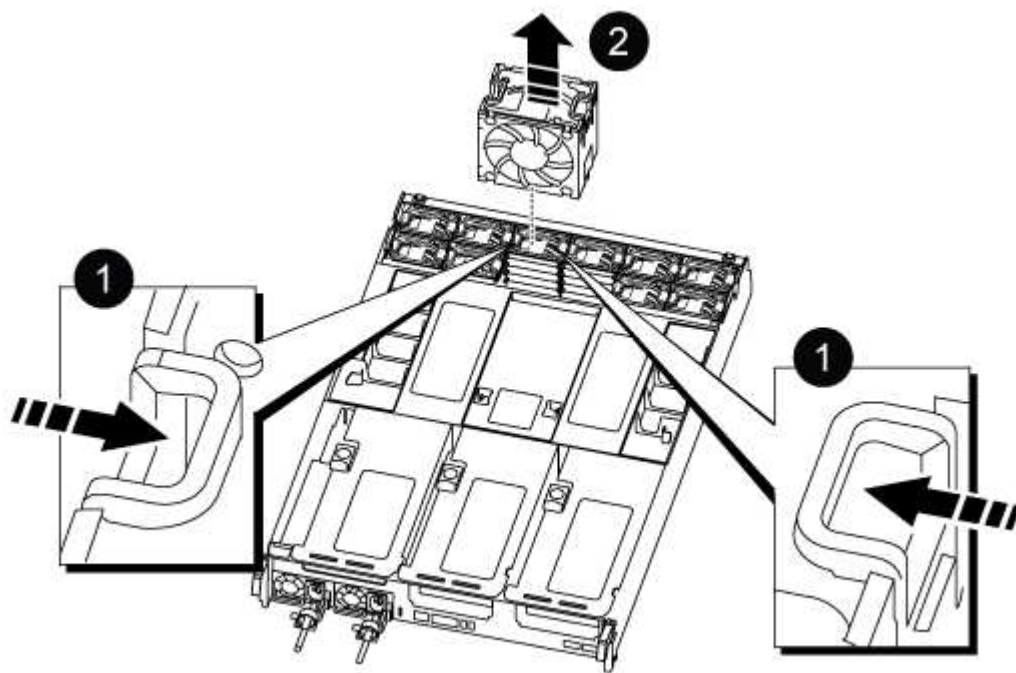

1	Fan locking tabs
2	Fan module

3. Align the edges of the replacement fan module with the opening in the controller module, and then slide the replacement fan module into the controller module until the locking latches click into place.



## Step 4: Reinstall the controller module

After you replace a component within the controller module, you must reinstall the controller module in the system chassis and boot it.

1. Align the end of the controller module with the opening in the chassis, and then gently push the controller module halfway into the system.



Do not completely insert the controller module in the chassis until instructed to do so.

2. Recable the system, as needed.
3. Plug the power cables into the power supplies and reinstall the power cable retainers.
4. Complete the reinstallation of the controller module:
  - a. Firmly push the controller module into the chassis until it meets the midplane and is fully seated.

The locking latches rise when the controller module is fully seated.



Do not use excessive force when sliding the controller module into the chassis to avoid damaging the connectors.

The controller module begins to boot as soon as it is fully seated in the chassis.

- b. Rotate the locking latches upward, tilting them so that they clear the locking pins, and then lower them into the locked position.
  - c. If you have not already done so, reinstall the cable management device.
5. Return the controller to normal operation by giving back its storage: `storage failover giveback -ofnode impaired_node_name`
  6. If automatic giveback was disabled, reenable it: `storage failover modify -controller local -auto-giveback true`

## Step 5: Return the failed part to NetApp

Return the failed part to NetApp, as described in the RMA instructions shipped with the kit. See the [Part Return and Replacements](#) page for further information.

### Replace an NVDIMM - ASA C800

You must replace the NVDIMM in the controller module when your system registers that the flash lifetime is almost at an end or that the identified NVDIMM is not healthy in general; failure to do so causes a system panic.

All other components in the system must be functioning properly; if not, you must contact technical support.

You must replace the failed component with a replacement FRU component you received from your provider.

### Step 1: Shut down the impaired controller

To shut down the impaired controller, you must determine the status of the controller and, if necessary, take over the controller so that the healthy controller continues to serve data from the impaired controller storage.

## About this task

- If you have a SAN system, you must have checked event messages (`cluster kernel-service show`) for the impaired controller SCSI blade. The `cluster kernel-service show` command (from `priv advanced mode`) displays the node name, quorum status of that node, availability status of that node, and operational status of that node.

Each SCSI-blade process should be in quorum with the other nodes in the cluster. Any issues must be resolved before you proceed with the replacement.

- If you have a cluster with more than two nodes, it must be in quorum. If the cluster is not in quorum or a healthy controller shows `false` for eligibility and health, you must correct the issue before shutting down the impaired controller; see [Synchronize a node with the cluster](#).

## Steps

1. If AutoSupport is enabled, suppress automatic case creation by invoking an AutoSupport message:  
`system node autosupport invoke -node * -type all -message MAINT=<# of hours>h`

The following AutoSupport message suppresses automatic case creation for two hours: `cluster1:> system node autosupport invoke -node * -type all -message MAINT=2h`

2. Disable automatic giveback from the console of the healthy controller: `storage failover modify -node local -auto-giveback false`



When you see *Do you want to disable auto-giveback?*, enter *y*.

3. Take the impaired controller to the LOADER prompt:

If the impaired controller is displaying...	Then...
The LOADER prompt	Go to the next step.
Waiting for giveback...	Press Ctrl-C, and then respond <i>y</i> when prompted.
System prompt or password prompt	Take over or halt the impaired controller from the healthy controller: <code>storage failover takeover -ofnode impaired_node_name</code>  When the impaired controller shows <i>Waiting for giveback...</i> , press Ctrl-C, and then respond <i>y</i> .

## Step 2: Remove the controller module

You must remove the controller module from the chassis when you replace the controller module or replace a component inside the controller module.

1. If you are not already grounded, properly ground yourself.
2. Unplug the controller module power supplies from the source.
3. Release the power cable retainers, and then unplug the cables from the power supplies.

- Loosen the hook and loop strap binding the cables to the cable management device, and then unplug the system cables and SFP and QSFP modules (if needed) from the controller module, keeping track of where the cables were connected.

Leave the cables in the cable management device so that when you reinstall the cable management device, the cables are organized.

- Remove the cable management device from the controller module and set it aside.
- Press down on both of the locking latches, and then rotate both latches downward at the same time.

The controller module moves slightly out of the chassis.

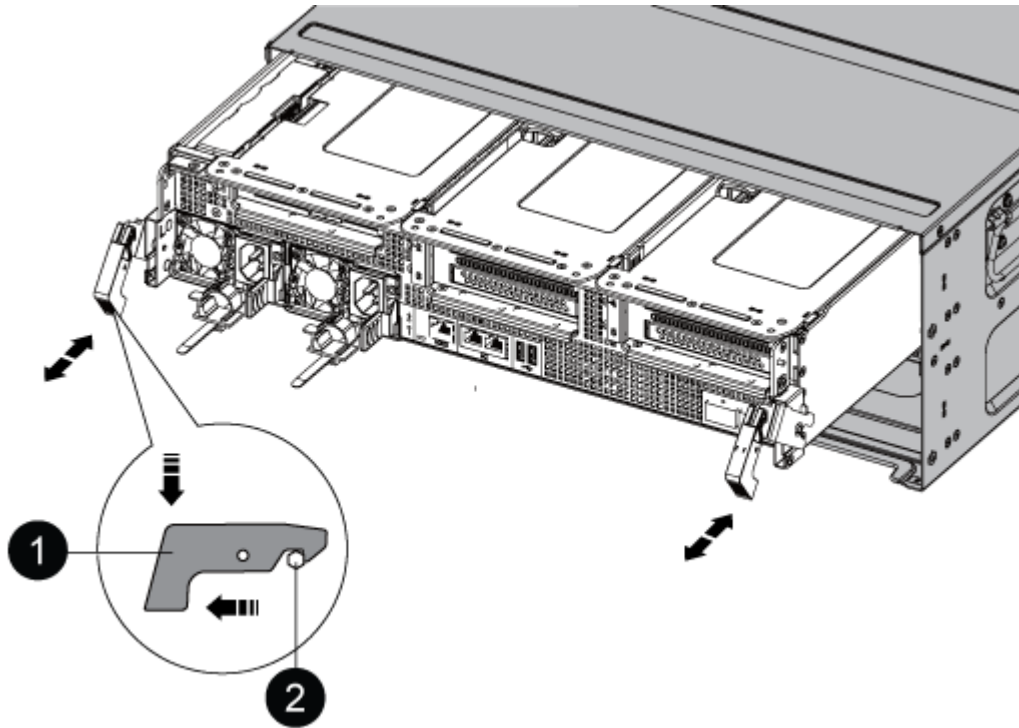

1	Locking latch
2	Locking pin

- Slide the controller module out of the chassis.

Make sure that you support the bottom of the controller module as you slide it out of the chassis.

- Place the controller module on a stable, flat surface, and then open the air duct:
  - Press in the locking tabs on the sides of the air duct toward the middle of the controller module.
  - Slide the air duct toward the fan modules, and then rotate it upward to its completely open position.

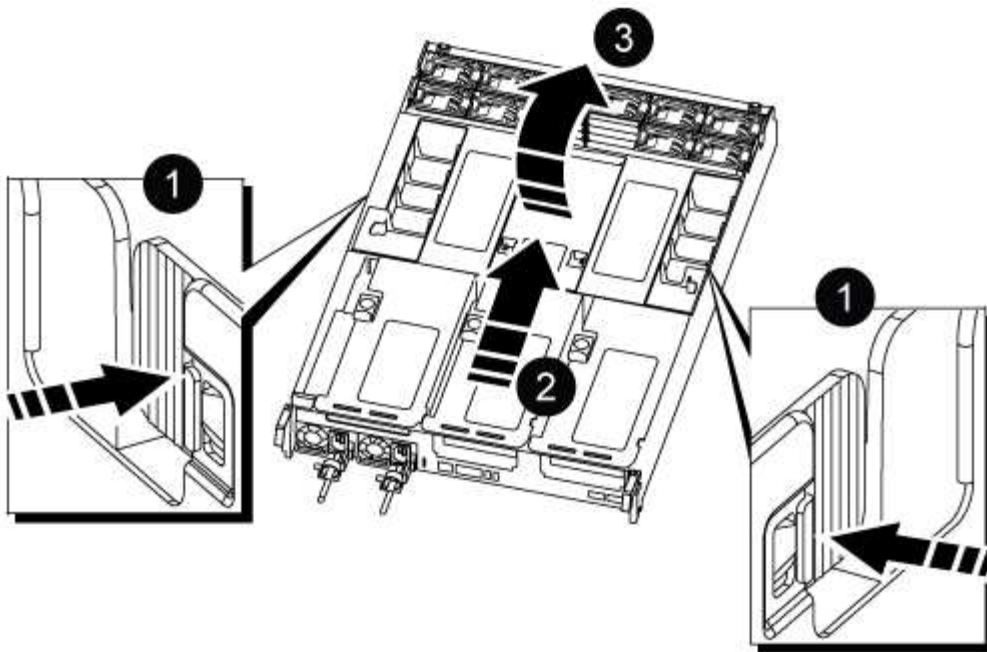

1	Air duct locking tabs
2	Slide air duct towards fan modules
3	Rotate air duct towards fan modules

### Step 3: Replace the NVDIMM

To replace the NVDIMM, you must locate it in the controller module using the NVDIMM map label on top of the air duct, and then replace it following the specific sequence of steps.

1. If you are removing or moving an NVDIMM, unlock the locking latch on the riser, and then remove the applicable riser.

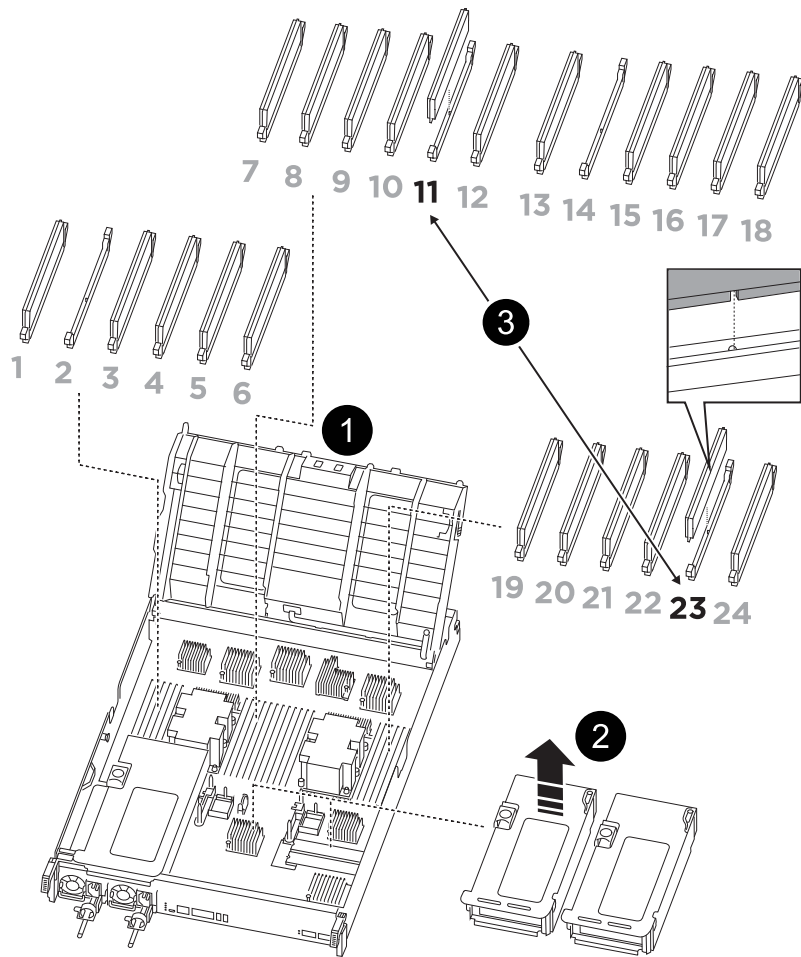

1	Air duct cover
2	Riser 2
3	NVDIMM in slots 11 and 23

2. Note the orientation of the NVDIMM in the socket so that you can insert the NVDIMM in the replacement controller module in the proper orientation.
3. Eject the NVDIMM from its slot by slowly pushing apart the two NVDIMM ejector tabs on either side of the NVDIMM, and then slide the NVDIMM out of the socket and set it aside.



Carefully hold the NVDIMM by the edges to avoid pressure on the components on the NVDIMM circuit board.

4. Remove the replacement NVDIMM from the antistatic shipping bag, hold the NVDIMM by the corners, and then align it to the slot.

The notch among the pins on the NVDIMM should line up with the tab in the socket.

5. Locate the slot where you are installing the NVDIMM.

6. Insert the NVDIMM squarely into the slot.

The NVDIMM fits tightly in the slot, but should go in easily. If not, realign the NVDIMM with the slot and reinsert it.



Visually inspect the NVDIMM to verify that it is evenly aligned and fully inserted into the slot.

7. Push carefully, but firmly, on the top edge of the NVDIMM until the ejector tabs snap into place over the notches at the ends of the NVDIMM.

8. Reinstall any risers that you removed from the controller module.

9. Close the air duct.

#### Step 4: Reinstall the controller module and booting the system

After you replace a FRU in the controller module, you must reinstall the controller module and reboot it.

1. If you have not already done so, close the air duct:

- a. Swing the air duct all the way down to the controller module.
- b. Slide the air duct toward the risers until the locking tabs click into place.
- c. Inspect the air duct to make sure that it is properly seated and locked into place.

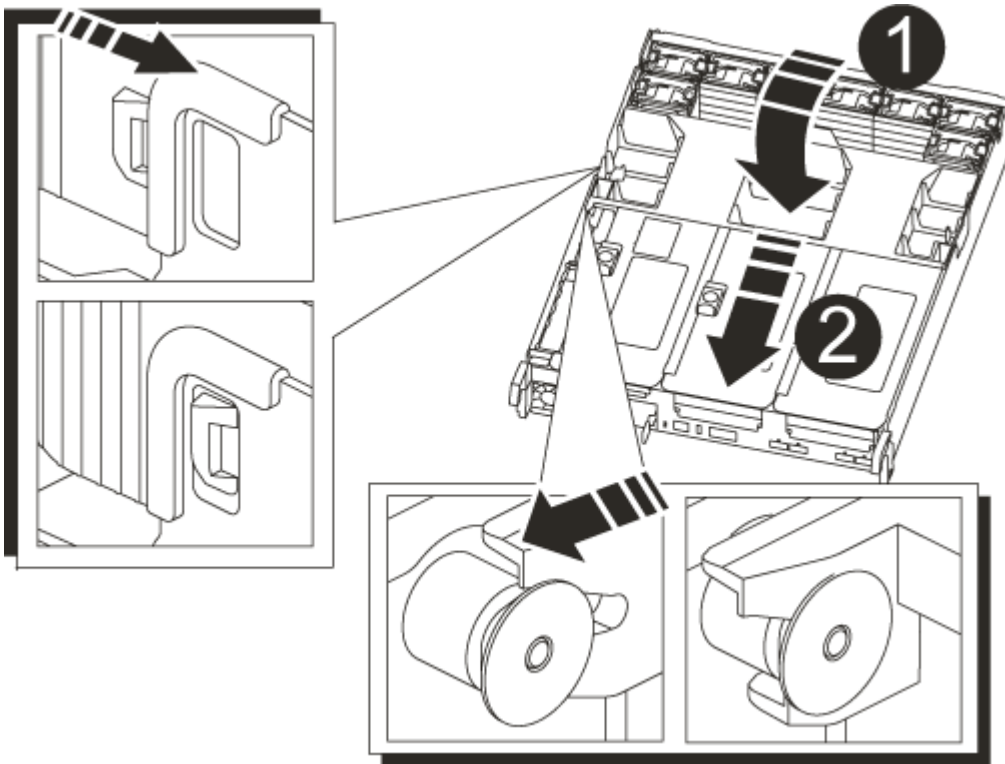

<b>1</b>	Locking tabs
<b>2</b>	Slide plunger

2. Align the end of the controller module with the opening in the chassis, and then gently push the controller module halfway into the system.



Do not completely insert the controller module in the chassis until instructed to do so.

3. Recable the system, as needed.

If you removed the media converters (QSFPs or SFPs), remember to reinstall them if you are using fiber optic cables.

4. Plug the power cord into the power supply, reinstall the power cable locking collar, and then connect the power supply to the power source.
5. Complete the reinstallation of the controller module:
  - a. Firmly push the controller module into the chassis until it meets the midplane and is fully seated.

The locking latches rise when the controller module is fully seated.



Do not use excessive force when sliding the controller module into the chassis to avoid damaging the connectors.

The controller module begins to boot as soon as it is fully seated in the chassis.

- b. Rotate the locking latches upward, tilting them so that they clear the locking pins, and then lower them into the locked position.
- c. If you have not already done so, reinstall the cable management device.

#### Step 4: Return the failed part to NetApp

Return the failed part to NetApp, as described in the RMA instructions shipped with the kit. See the [Part Return and Replacements](#) page for further information.

#### Replace the NVDIMM battery - ASA C800

To replace the NVDIMM battery, you must remove the controller module, remove the battery, replace the battery, and then reinstall the controller module.

All other components in the system must be functioning properly; if not, you must contact technical support.

#### Step 1: Shut down the impaired controller

To shut down the impaired controller, you must determine the status of the controller and, if necessary, take over the controller so that the healthy controller continues to serve data from the impaired controller storage.

#### About this task

- If you have a SAN system, you must have checked event messages (`cluster kernel-service show`) for the impaired controller SCSI blade. The `cluster kernel-service show` command (from `priv advanced mode`) displays the node name, quorum status of that node, availability status of that node, and operational status of that node.

Each SCSI-blade process should be in quorum with the other nodes in the cluster. Any issues must be resolved before you proceed with the replacement.

- If you have a cluster with more than two nodes, it must be in quorum. If the cluster is not in quorum or a healthy controller shows false for eligibility and health, you must correct the issue before shutting down the impaired controller; see [Synchronize a node with the cluster](#).

## Steps

1. If AutoSupport is enabled, suppress automatic case creation by invoking an AutoSupport message:  

```
system node autosupport invoke -node * -type all -message MAINT=<# of hours>h
```

The following AutoSupport message suppresses automatic case creation for two hours: `cluster1:>`  

```
system node autosupport invoke -node * -type all -message MAINT=2h
```

2. Disable automatic giveback from the console of the healthy controller: `storage failover modify -node local -auto-giveback false`



When you see *Do you want to disable auto-giveback?*, enter *y*.

3. Take the impaired controller to the LOADER prompt:

If the impaired controller is displaying...	Then...
The LOADER prompt	Go to the next step.
Waiting for giveback...	Press Ctrl-C, and then respond <i>y</i> when prompted.
System prompt or password prompt	Take over or halt the impaired controller from the healthy controller: <pre>storage failover takeover -ofnode impaired_node_name</pre> <p>When the impaired controller shows <i>Waiting for giveback...</i>, press Ctrl-C, and then respond <i>y</i>.</p>

## Step 2: Remove the controller module

You must remove the controller module from the chassis when you replace the controller module or replace a component inside the controller module.

1. If you are not already grounded, properly ground yourself.
2. Unplug the controller module power supplies from the source.
3. Release the power cable retainers, and then unplug the cables from the power supplies.
4. Loosen the hook and loop strap binding the cables to the cable management device, and then unplug the system cables and SFP and QSFP modules (if needed) from the controller module, keeping track of where the cables were connected. Loosen the hook and loop strap binding the cables to the cable management device, and then unplug the system cables from the controller module, keeping track of where the cables were connected.

Leave the cables in the cable management device so that when you reinstall the cable management device, the cables are organized.



5. Remove the cable management device from the controller module and set it aside.
6. Press down on both of the locking latches, and then rotate both latches downward at the same time.

The controller module moves slightly out of the chassis.

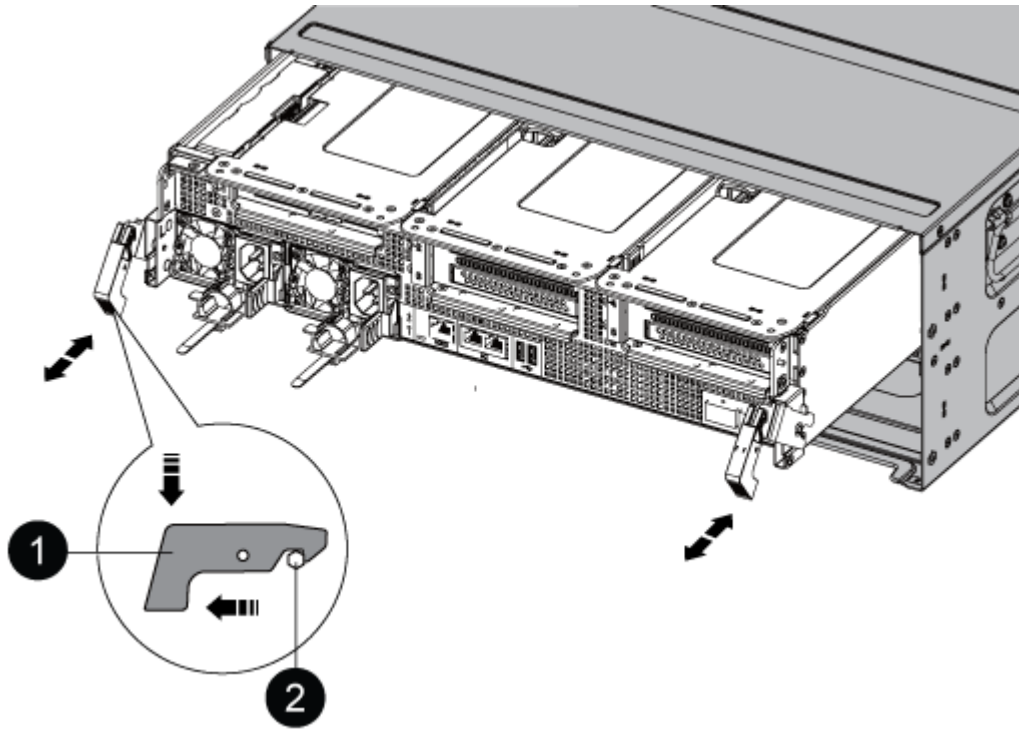

<b>1</b>	Locking latch
<b>2</b>	Locking pin

7. Slide the controller module out of the chassis.

Make sure that you support the bottom of the controller module as you slide it out of the chassis.

8. Set the controller module aside in a safe place.

### Step 3: Replace the NVDIMM battery

To replace the NVDIMM battery, you must remove the failed battery from the controller module and install the replacement battery into the controller module.

1. Open the air duct cover and locate the NVDIMM battery in the riser.

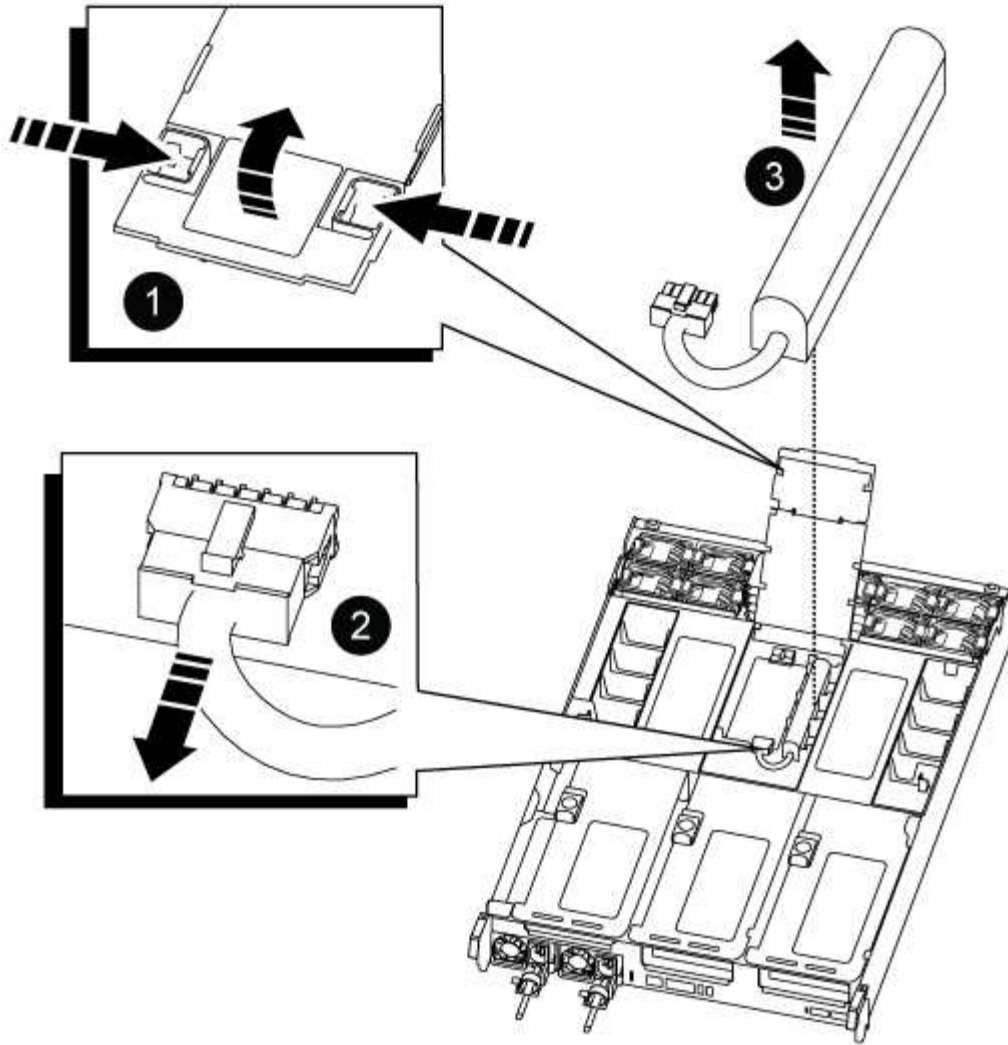

1	Air duct riser
2	NVDIMM battery plug
3	NVDIMM battery pack

**Attention:** The NVDIMM battery control board LED blinks while destaging contents to the flash memory when you halt the system. After the destage is complete, the LED turns off.

1. Locate the battery plug and squeeze the clip on the face of the battery plug to release the plug from the socket, and then unplug the battery cable from the socket.
2. Grasp the battery and lift the battery out of the air duct and controller module, and then set it aside.
3. Remove the replacement battery from its package.
4. Install the replacement battery pack in the NVDIMM air duct:
  - a. Insert the battery pack into the slot and press firmly down on the battery pack to make sure that it is locked into place.

- b. Plug the battery plug into the riser socket and make sure that the plug locks into place.
5. Close the NVDIMM air duct.

Make sure that the plug locks into the socket.

#### Step 4: Reinstall the controller module and booting the system

After you replace a FRU in the controller module, you must reinstall the controller module and reboot it.

1. Align the end of the controller module with the opening in the chassis, and then gently push the controller module halfway into the system.



Do not completely insert the controller module in the chassis until instructed to do so.

2. Recable the system, as needed.

If you removed the media converters (QSFPs or SFPs), remember to reinstall them if you are using fiber optic cables.

3. Plug the power cord into the power supply, reinstall the power cable locking collar, and then connect the power supply to the power source.
4. Complete the reinstallation of the controller module:
  - a. Firmly push the controller module into the chassis until it meets the midplane and is fully seated.

The locking latches rise when the controller module is fully seated.



Do not use excessive force when sliding the controller module into the chassis to avoid damaging the connectors.

The controller module begins to boot as soon as it is fully seated in the chassis.

- b. Rotate the locking latches upward, tilting them so that they clear the locking pins, and then lower them into the locked position.
- c. If you have not already done so, reinstall the cable management device.

#### Step 5: Return the failed part to NetApp

Return the failed part to NetApp, as described in the RMA instructions shipped with the kit. See the [Part Return and Replacements](#) page for further information.

##### Replace a PCIe card - ASA C800

To replace a PCIe card, you must disconnect the cables from the cards, remove the SFP and QSFP modules from the cards before removing the riser, reinstall the riser, and then reinstall the SFP and QSFP modules before cabling the cards.

- You can use this procedure with all versions of ONTAP supported by your system
- All other components in the system must be functioning properly; if not, you must contact technical support.

## Step 1: Shut down the impaired controller

To shut down the impaired controller, you must determine the status of the controller and, if necessary, take over the controller so that the healthy controller continues to serve data from the impaired controller storage.

### About this task

- If you have a SAN system, you must have checked event messages (`cluster kernel-service show`) for the impaired controller SCSI blade. The `cluster kernel-service show` command (from `priv advanced mode`) displays the node name, quorum status of that node, availability status of that node, and operational status of that node.

Each SCSI-blade process should be in quorum with the other nodes in the cluster. Any issues must be resolved before you proceed with the replacement.

- If you have a cluster with more than two nodes, it must be in quorum. If the cluster is not in quorum or a healthy controller shows false for eligibility and health, you must correct the issue before shutting down the impaired controller; see [Synchronize a node with the cluster](#).

### Steps

1. If AutoSupport is enabled, suppress automatic case creation by invoking an AutoSupport message:  
`system node autosupport invoke -node * -type all -message MAINT=<# of hours>h`

The following AutoSupport message suppresses automatic case creation for two hours: `cluster1:>`  
`system node autosupport invoke -node * -type all -message MAINT=2h`

2. Disable automatic giveback from the console of the healthy controller: `storage failover modify -node local -auto-giveback false`



When you see *Do you want to disable auto-giveback?*, enter *y*.

3. Take the impaired controller to the LOADER prompt:

If the impaired controller is displaying...	Then...
The LOADER prompt	Go to the next step.
Waiting for giveback...	Press Ctrl-C, and then respond <i>y</i> when prompted.
System prompt or password prompt	Take over or halt the impaired controller from the healthy controller: <code>storage failover takeover -ofnode impaired_node_name</code>  When the impaired controller shows <i>Waiting for giveback...</i> , press Ctrl-C, and then respond <i>y</i> .

## Step 2: Remove the controller module

You must remove the controller module from the chassis when you replace the controller module or replace a component inside the controller module.

1. If you are not already grounded, properly ground yourself.
2. Unplug the controller module power supplies from the source.
3. Release the power cable retainers, and then unplug the cables from the power supplies.
4. Loosen the hook and loop strap binding the cables to the cable management device, and then unplug the system cables and SFP and QSFP modules (if needed) from the controller module, keeping track of where the cables were connected.

Leave the cables in the cable management device so that when you reinstall the cable management device, the cables are organized.

5. Remove the cable management device from the controller module and set it aside.
6. Press down on both of the locking latches, and then rotate both latches downward at the same time.

The controller module moves slightly out of the chassis.

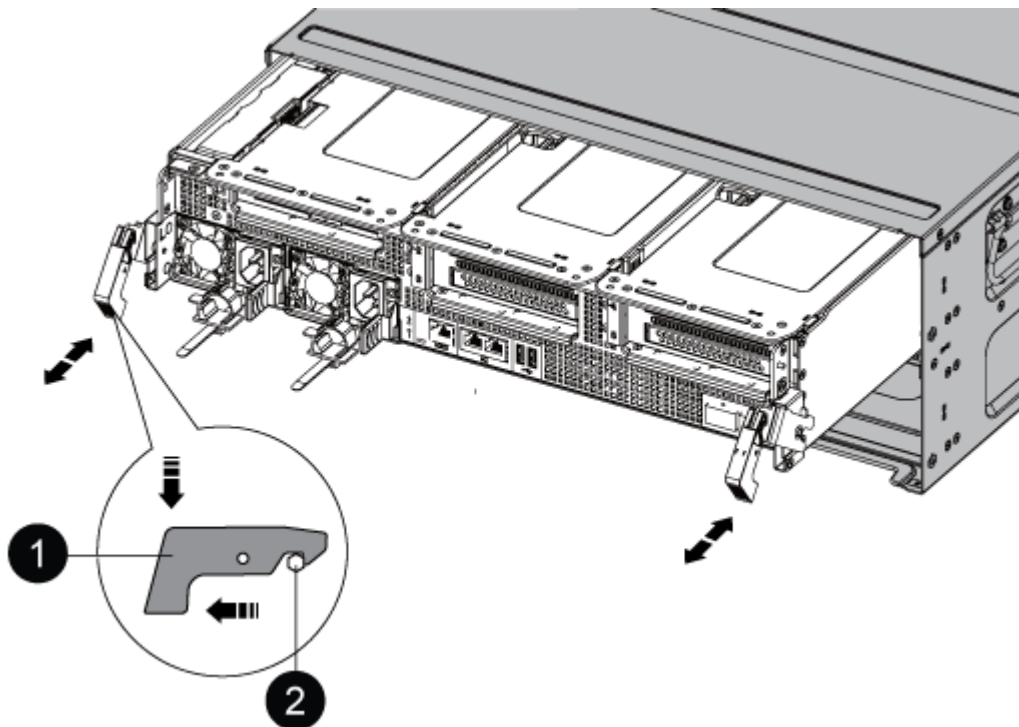

<b>1</b>	Locking latch
<b>2</b>	Locking pin

7. Slide the controller module out of the chassis.

Make sure that you support the bottom of the controller module as you slide it out of the chassis.

8. Place the controller module on a stable, flat surface, and then open the air duct:
  - a. Press in the locking tabs on the sides of the air duct toward the middle of the controller module.
  - b. Slide the air duct toward the fan modules, and then rotate it upward to its completely open position.

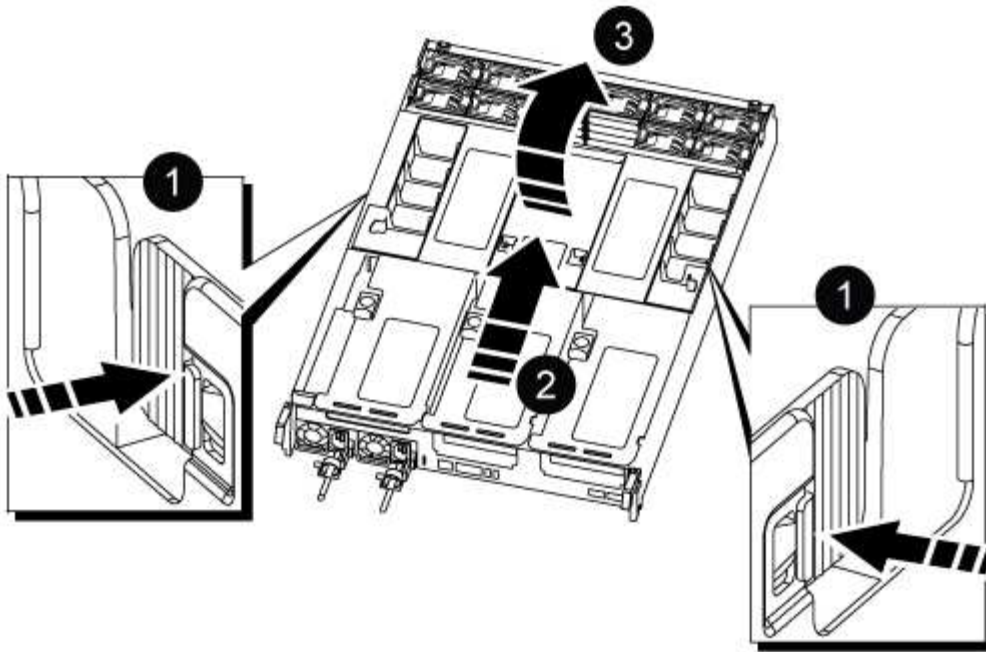

1	Air duct locking tabs
2	Slide air duct towards fan modules
3	Rotate air duct towards fan modules

### Step 3: Replace a PCIe card

To replace a PCIe card, you must remove the cabling and any QSFPs and SFPs from the ports on the PCIe cards in the target riser, remove the riser from the controller module, remove and replace the PCIe card, reinstall the riser and any QSFPs and SFPs onto the ports, and cable the ports.

1. Determine if the card you are replacing is from Riser 1 or if it is from Riser 2 or 3.
  - If you are replacing the 100GbE PCIe card in Riser 1, use Steps 2 - 3 and Steps 6 - 7.
  - If you are replacing a PCIe card from Riser 2 or 3, use Steps 4 through 7.
2. Remove Riser 1 from the controller module:
  - a. Remove the QSFP modules that might be in the PCIe card.
  - b. Rotate the riser locking latch on the left side of the riser up and toward the fan modules.  
  
The riser raises up slightly from the controller module.
  - c. Lift the riser up, shift it toward the fans so that the sheet metal lip on the riser clears the edge of the controller module, lift the riser out of the controller module, and then place it on a stable, flat surface.

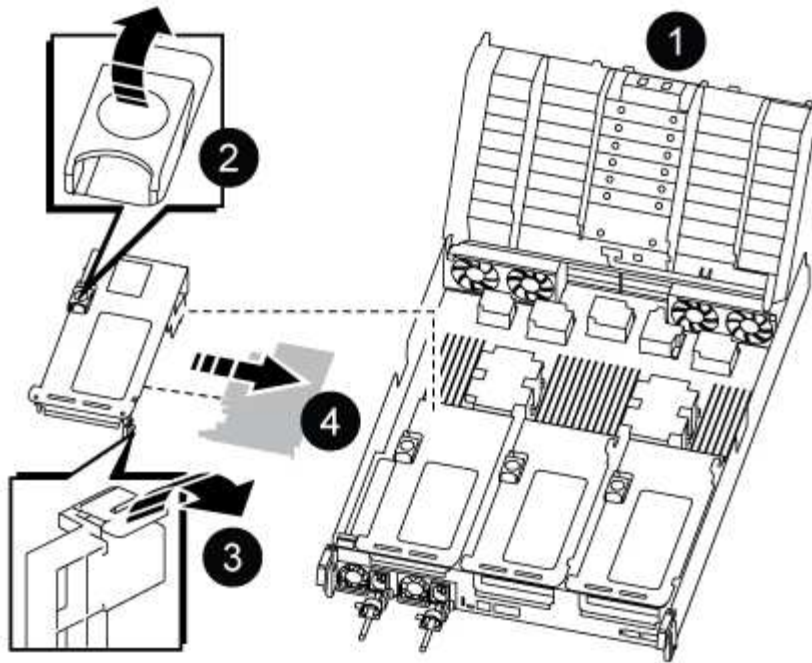

1	Air duct
2	Riser locking latch
3	Card locking bracket
4	Riser 1 (left riser) with 100GbE PCIe card in slot 1.

3. Remove the PCIe card from Riser 1:

- a. Turn the riser so that you can access the PCIe card.
- b. Press the locking bracket on the side of the PCIe riser, and then rotate it to the open position.
- c. Remove the PCIe card from the riser.

4. Remove the PCIe riser from the controller module:

- a. Remove any SFP or QSFP modules that might be in the PCIe cards.
- b. Rotate the riser locking latch on the left side of the riser up and toward the fan modules.

The riser raises up slightly from the controller module.

- c. Lift the riser up, shift it toward the fans so that the sheet metal lip on the riser clears the edge of the controller module, lift the riser out of the controller module, and then place it on a stable, flat surface.

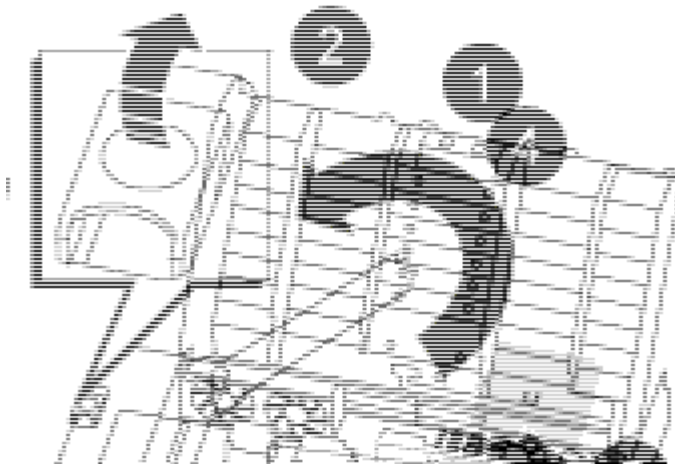

1	Air duct
2	Riser 2 (middle riser) or 3 (right riser) locking latch
3	Card locking bracket
4	Side panel on riser 2 or 3
5	PCIe cards in riser 2 or 3

5. Remove the PCIe card from the riser:
  - a. Turn the riser so that you can access the PCIe cards.
  - b. Press the locking bracket on the side of the PCIe riser, and then rotate it to the open position.
  - c. Swing the side panel off the riser.
  - d. Remove the PCIe card from the riser.
6. Install the PCIe card into the same slot in the riser:
  - a. Align the card with the card socket in the riser, and then slide it squarely into the socket in the riser.
 

 Make sure that the card is completely and squarely seated into the riser socket.
  - b. For Riser 2 or 3, close the side panel.
  - c. Swing the locking latch into place until it clicks into the locked position.
7. Install the riser into the controller module:
  - a. Align the lip of the riser with the underside of the controller module sheet metal.
  - b. Guide the riser along the pins in the controller module, and then lower the riser into the controller module.
  - c. Swing the locking latch down and click it into the locked position.

When locked, the locking latch is flush with the top of the riser and the riser sits squarely in the



controller module.

- d. Reinsert any SFP modules that were removed from the PCIe cards.

#### Step 4: Reinstall the controller module

After you replace a component within the controller module, you must reinstall the controller module in the system chassis and boot it.

1. If you have not already done so, close the air duct:
  - a. Swing the air duct all the way down to the controller module.
  - b. Slide the air duct toward the risers until the locking tabs click into place.
  - c. Inspect the air duct to make sure that it is properly seated and locked into place.

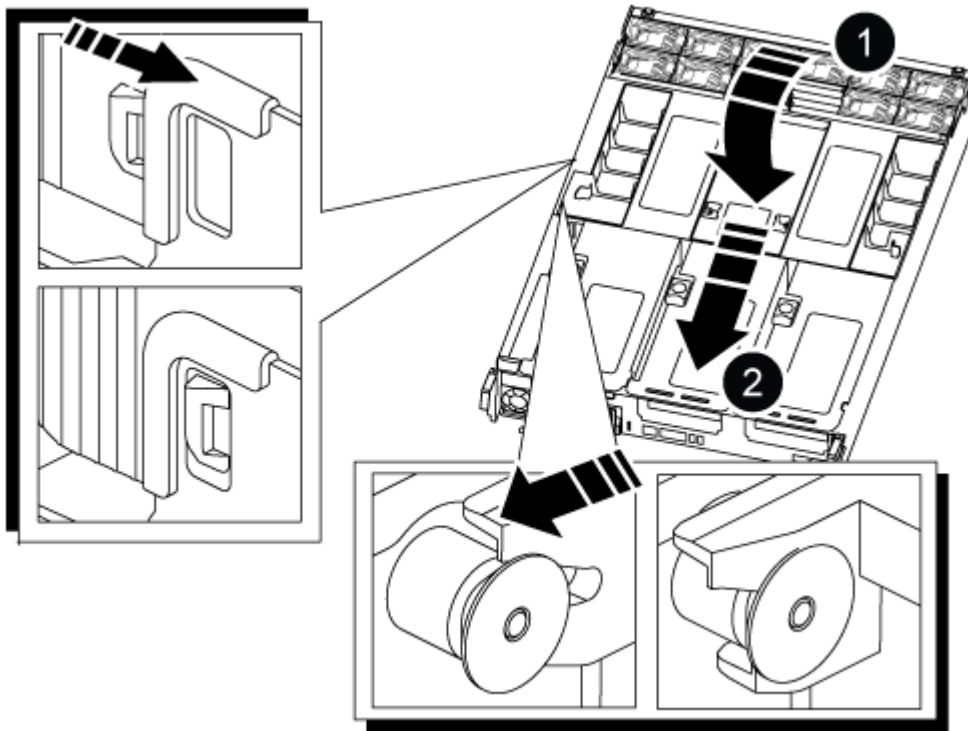

<b>1</b>	Locking tabs
<b>2</b>	Slide plunger

2. Align the end of the controller module with the opening in the chassis, and then gently push the controller module halfway into the system.



Do not completely insert the controller module in the chassis until instructed to do so.

3. Cable the management and console ports only, so that you can access the system to perform the tasks in the following sections.



You will connect the rest of the cables to the controller module later in this procedure.

4. Complete the reinstallation of the controller module:

- a. Firmly push the controller module into the chassis until it meets the midplane and is fully seated.

The locking latches rise when the controller module is fully seated.



Do not use excessive force when sliding the controller module into the chassis to avoid damaging the connectors.

- b. Rotate the locking latches upward, tilting them so that they clear the locking pins, and then lower them into the locked position.

5. Plug the system cables and transceiver modules into the controller module and reinstall the cable management device.

6. Plug the power cables into the power supplies and reinstall the power cable retainers.

The controller module begins to boot as soon as it is connected to power. Be prepared to interrupt the boot process.



If your system has DC power supplies, make sure the thumbscrews on the power supply cable are tight.

7. Return the controller to normal operation by giving back its storage: `storage failover giveback -ofnode impaired_node_name`

8. If automatic giveback was disabled, reenable it: `storage failover modify -node local -auto-giveback true`

### Step 5: Return the failed part to NetApp

Return the failed part to NetApp, as described in the RMA instructions shipped with the kit. See the [Part Return and Replacements](#) page for further information.

#### Replace a power supply - ASA C800

Replacing a power supply (PSU) involves disconnecting the target PSU from the power source, unplugging the power cable, removing the old PSU and installing the replacement PSU, and then reconnecting it to the power source.

The power supplies are redundant and hot-swappable.

#### About this task

This procedure is written for replacing one PSU at a time.



It is a best practice to replace the PSU within two minutes of removing it from the chassis. The system continues to function, but ONTAP sends messages to the console about the degraded PSU until the PSU is replaced.



Do not mix PSUs with different efficiency ratings or different input types. Always replace like for like.

Use the appropriate procedure for your type of PSU: AC or DC.

### Option 1: Replace an AC PSU

To replace an AC PSU, complete the following steps.

1. If you are not already grounded, properly ground yourself.
2. Identify the PSU you want to replace, based on console error messages or through the red Fault LED on the PSU.
3. Disconnect the PSU:
  - a. Open the power cable retainer, and then unplug the power cable from the PSU.
  - b. Unplug the power cable from the power source.
4. Remove the PSU by rotating the handle up, press the locking tab, and then pull PSU out of the controller module.



The PSU is short. Always use two hands to support it when removing it from the controller module so that it does not suddenly swing free from the controller module and injure you.

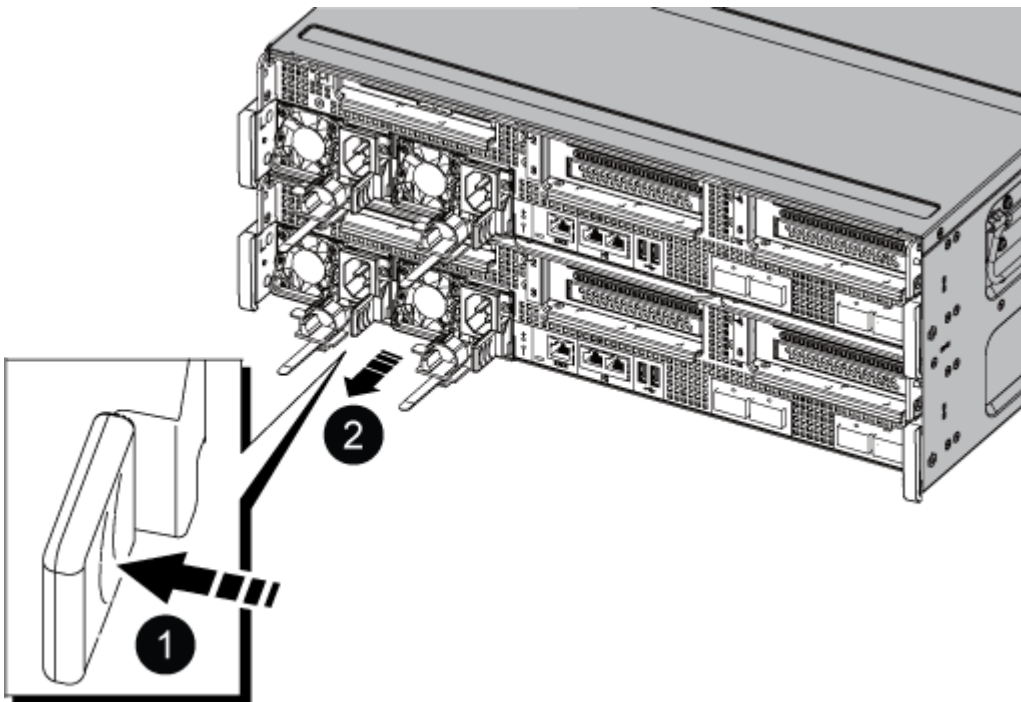

1	Blue PSU locking tab
2	Power supply

5. Install the replacement PSU in the controller module:
  - a. Using both hands, support and align the edges of the replacement PSU with the opening in the controller module.
  - b. Gently push the PSU into the controller module until the locking tab clicks into place.

The power supplies will only properly engage with the internal connector and lock in place one

way.



To avoid damaging the internal connector, do not use excessive force when sliding the PSU into the system.

6. Reconnect the PSU cabling:

- a. Reconnect the power cable to the PSU and the power source.
- b. Secure the power cable to the PSU using the power cable retainer.

Once power is restored to the PSU, the status LED should be green.

7. Return the failed part to NetApp, as described in the RMA instructions shipped with the kit. See the [Part Return and Replacements](#) page for further information.

### Option 2: Replace a DC PSU

To replace a DC PSU, complete the following steps.

1. If you are not already grounded, properly ground yourself.
2. Identify the PSU you want to replace, based on console error messages or through the red Fault LED on the PSU.
3. Disconnect the PSU:
  - a. Unscrew the D-SUB DC cable connector using the thumb screws on the plug.
  - b. Unplug the cable from the PSU and set it aside.
4. Remove the PSU by rotating the handle up, press the locking tab, and then pull the PSU out of the controller module.



The PSU is short. Always use two hands to support it when removing it from the controller module so that it does not suddenly swing free from the controller module and injure you.

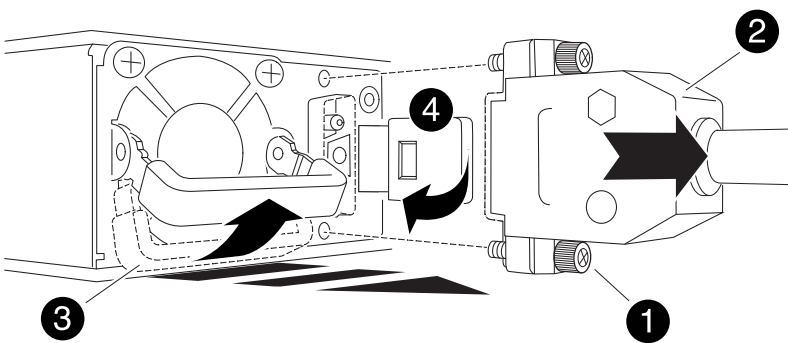

1	Thumb screws
2	D-SUB DC power PSU cable connector
3	Power supply handle

4

## Blue PSU locking tab

5. Install the replacement PSU in the controller module:

- a. Using both hands, support and align the edges of the replacement PSU with the opening in the controller module.
- b. Gently push the PSU into the controller module until the locking tab clicks into place.

The power supplies will only properly engage with the internal connector and lock in place one way.



To avoid damaging the internal connector, do not use excessive force when sliding the PSU into the system.

6. Reconnect the D-SUB DC power cable:

- a. Plug the power cable connector into the PSU.
- b. Secure the power cable to the PSU with the thumbscrews.

Once power is restored to the PSU, the status LED should be green.

7. Return the failed part to NetApp, as described in the RMA instructions shipped with the kit. See the [Part Return and Replacements](#) page for further information.

### Replace the real-time clock battery - ASA C800

You replace the real-time clock (RTC) battery in the controller module so that your system's services and applications that depend on accurate time synchronization continue to function.

- You can use this procedure with all versions of ONTAP supported by your system
- All other components in the system must be functioning properly; if not, you must contact technical support.

#### Step 1: Shut down the impaired controller

To shut down the impaired controller, you must determine the status of the controller and, if necessary, take over the controller so that the healthy controller continues to serve data from the impaired controller storage.

#### About this task

- If you have a SAN system, you must have checked event messages (`cluster kernel-service show`) for the impaired controller SCSI blade. The `cluster kernel-service show` command (from `priv advanced mode`) displays the node name, quorum status of that node, availability status of that node, and operational status of that node.

Each SCSI-blade process should be in quorum with the other nodes in the cluster. Any issues must be resolved before you proceed with the replacement.

- If you have a cluster with more than two nodes, it must be in quorum. If the cluster is not in quorum or a healthy controller shows false for eligibility and health, you must correct the issue before shutting down the impaired controller; see [Synchronize a node with the cluster](#).

## Steps

1. If AutoSupport is enabled, suppress automatic case creation by invoking an AutoSupport message:  
`system node autosupport invoke -node * -type all -message MAINT=<# of hours>h`

The following AutoSupport message suppresses automatic case creation for two hours: `cluster1:>`  
`system node autosupport invoke -node * -type all -message MAINT=2h`

2. Disable automatic giveback from the console of the healthy controller: `storage failover modify -node local -auto-giveback false`



When you see *Do you want to disable auto-giveback?*, enter *y*.

3. Take the impaired controller to the LOADER prompt:

If the impaired controller is displaying...	Then...
The LOADER prompt	Go to the next step.
Waiting for giveback...	Press Ctrl-C, and then respond <i>y</i> when prompted.
System prompt or password prompt	Take over or halt the impaired controller from the healthy controller: <code>storage failover takeover -ofnode impaired_node_name</code>  When the impaired controller shows Waiting for giveback..., press Ctrl-C, and then respond <i>y</i> .

## Step 2: Remove the controller module

You must remove the controller module from the chassis when you replace the controller module or replace a component inside the controller module.

1. If you are not already grounded, properly ground yourself.
2. Unplug the controller module power supplies from the source.
3. Release the power cable retainers, and then unplug the cables from the power supplies.
4. Loosen the hook and loop strap binding the cables to the cable management device, and then unplug the system cables and SFP and QSFP modules (if needed) from the controller module, keeping track of where the cables were connected.

Leave the cables in the cable management device so that when you reinstall the cable management device, the cables are organized.

5. Remove the cable management device from the controller module and set it aside.
6. Press down on both of the locking latches, and then rotate both latches downward at the same time.

The controller module moves slightly out of the chassis.

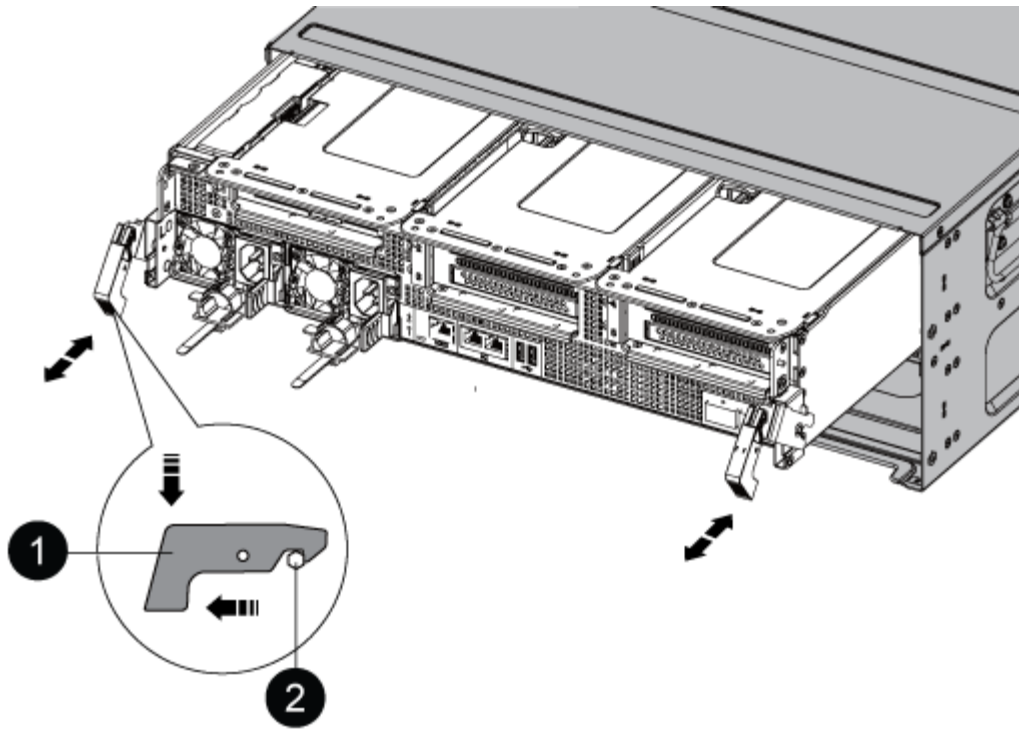

1	Locking latch
2	Locking pin

1. Slide the controller module out of the chassis.

Make sure that you support the bottom of the controller module as you slide it out of the chassis.

2. Place the controller module on a stable, flat surface, and then open the air duct:

- a. Press in the locking tabs on the sides of the air duct toward the middle of the controller module.
- b. Slide the air duct toward the fan modules, and then rotate it upward to its completely open position.

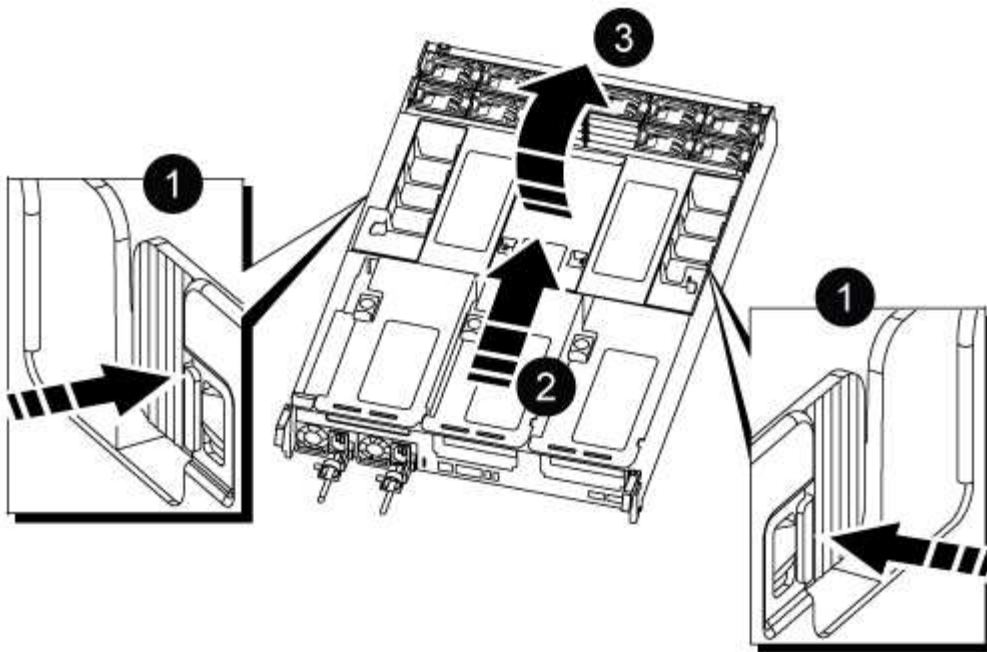

1	Air duct locking tabs
2	Slide air duct towards fan modules
3	Rotate air duct towards fan modules

**Step 3: Replace the RTC battery**



## Original controller

1. Remove PCIe riser 2 (middle riser) from the controller module:
  - a. Remove any SFP or QSFP modules that might be in the PCIe cards.
  - b. Rotate the riser locking latch on the left side of the riser up and toward the fan modules.

The riser raises up slightly from the controller module.

- c. Lift the riser up, shift it toward the fans so that the sheet metal lip on the riser clears the edge of the controller module, lift the riser out of the controller module, and then place it on a stable, flat surface.

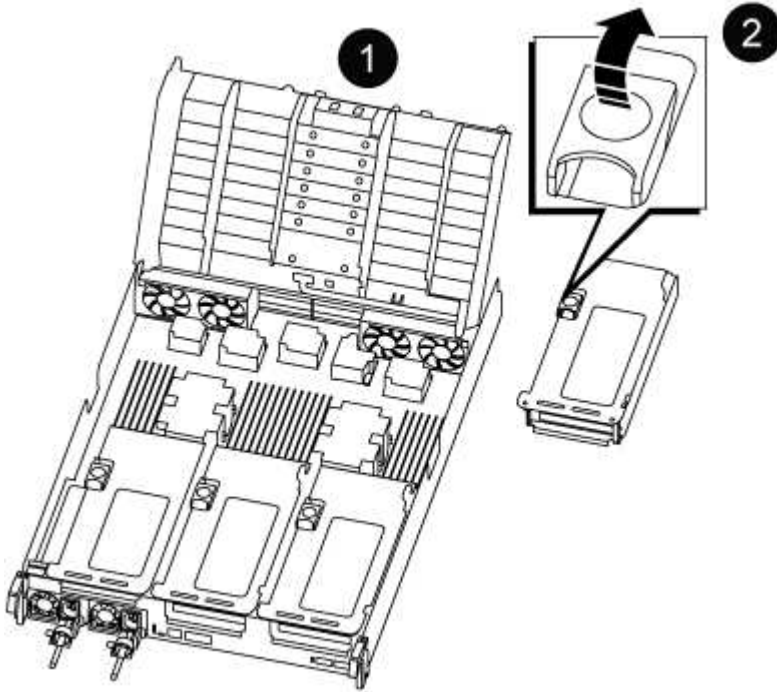

<b>1</b>	Air duct
<b>2</b>	Riser 2 (middle riser) locking latch

2. Locate the RTC battery under Riser 2.

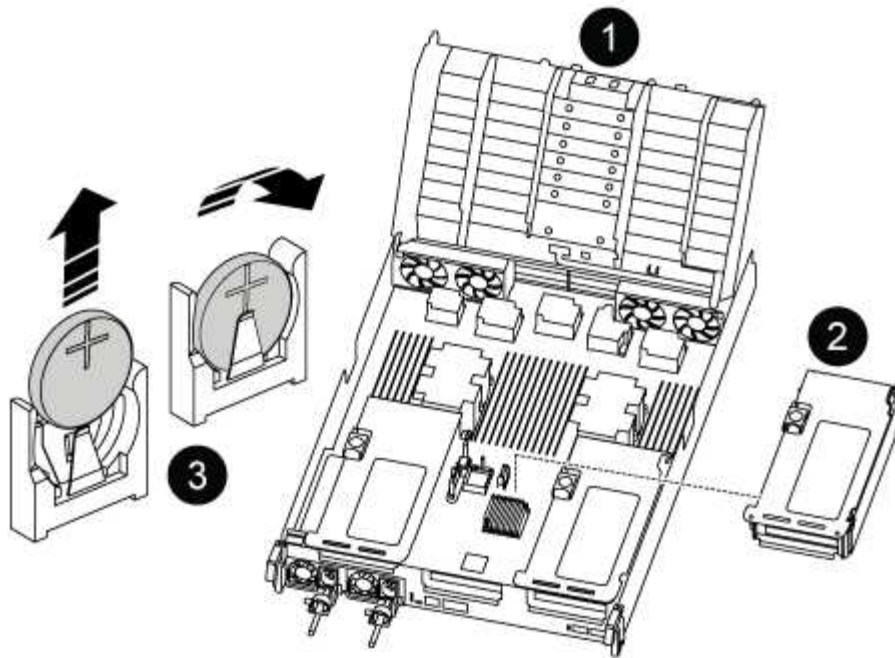

1	Air duct
2	Riser 2
3	RTC battery and housing

3. Gently push the battery away from the holder, rotate it away from the holder, and then lift it out of the holder.



Note the polarity of the battery as you remove it from the holder. The battery is marked with a plus sign and must be positioned in the holder correctly. A plus sign near the holder tells you how the battery should be positioned.

4. Remove the replacement battery from the antistatic shipping bag.
5. Note the polarity of the RTC battery, and then insert it into the holder by tilting the battery at an angle and pushing down.
6. Visually inspect the battery to make sure that it is completely installed into the holder and that the polarity is correct.
7. Install the riser into the controller module:
  - a. Align the lip of the riser with the underside of the controller module sheet metal.
  - b. Guide the riser along the pins in the controller module, and then lower the riser into the controller module.
  - c. Swing the locking latch down and click it into the locked position.

When locked, the locking latch is flush with the top of the riser and the riser sits squarely in the controller module.

- d. Reinsert any SFP modules that were removed from the PCIe cards.

### VER2 controller

1. Locate the RTC battery near the DIMMs.

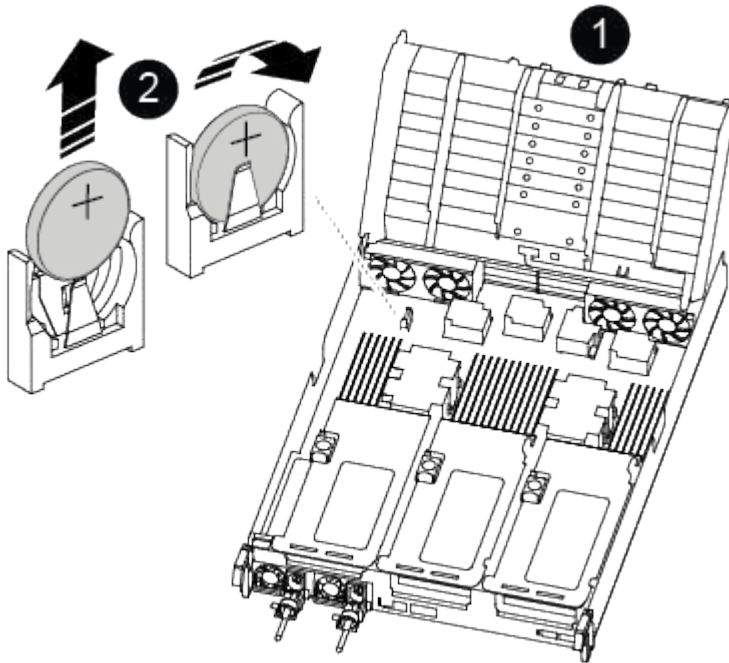

1	Air duct
2	RTC battery and housing

2. Gently push the battery away from the holder, rotate it away from the holder, and then lift it out of the holder.



Note the polarity of the battery as you remove it from the holder. The battery is marked with a plus sign and must be positioned in the holder correctly. A plus sign near the holder tells you how the battery should be positioned.

3. Remove the replacement battery from the antistatic shipping bag.
4. Note the polarity of the RTC battery, and then insert it into the holder by tilting the battery at an angle and pushing down.
5. Visually inspect the battery to make sure that it is completely installed into the holder and that the polarity is correct.

### Step 4: Reinstall the controller module

After you replace a component within the controller module, you must reinstall the controller module in the system chassis, reset the time and date on the controller, and then boot it.

1. If you have not already done so, close the air duct or controller module cover.

2. Align the end of the controller module with the opening in the chassis, and then gently push the controller module halfway into the system.

Do not completely insert the controller module in the chassis until instructed to do so.

3. Recable the system, as needed.

If you removed the media converters (QSFPs or SFPs), remember to reinstall them if you are using fiber optic cables.

4. If the power supplies were unplugged, plug them back in and reinstall the power cable retainers.
5. Complete the reinstallation of the controller module:

- a. Firmly push the controller module into the chassis until it meets the midplane and is fully seated.

The locking latches rise when the controller module is fully seated.



Do not use excessive force when sliding the controller module into the chassis to avoid damaging the connectors.

The controller module begins to boot as soon as it is fully seated in the chassis.

- b. Rotate the locking latches upward, tilting them so that they clear the locking pins, and then lower them into the locked position.
- c. If you have not already done so, reinstall the cable management device.
- d. Halt the controller at the LOADER prompt.
6. Reset the time and date on the controller:
  - a. Check the date and time on the healthy controller with the `show date` command.
  - b. At the LOADER prompt on the target controller, check the time and date.
  - c. If necessary, modify the date with the `set date mm/dd/yyyy` command.
  - d. If necessary, set the time, in GMT, using the `set time hh:mm:ss` command.
  - e. Confirm the date and time on the target controller.
7. At the LOADER prompt, enter `bye` to reinitialize the PCIe cards and other components and let the controller reboot.
8. Return the controller to normal operation by giving back its storage: `storage failover giveback -ofnode impaired_node_name`
9. If automatic giveback was disabled, reenable it: `storage failover modify -node local -auto-giveback true`

## Step 5: Return the failed part to NetApp

Return the failed part to NetApp, as described in the RMA instructions shipped with the kit. See the [Part Return and Replacements](#) page for further information.

## Copyright information

Copyright © 2024 NetApp, Inc. All Rights Reserved. Printed in the U.S. No part of this document covered by copyright may be reproduced in any form or by any means—graphic, electronic, or mechanical, including photocopying, recording, taping, or storage in an electronic retrieval system—without prior written permission of the copyright owner.

Software derived from copyrighted NetApp material is subject to the following license and disclaimer:

THIS SOFTWARE IS PROVIDED BY NETAPP “AS IS” AND WITHOUT ANY EXPRESS OR IMPLIED WARRANTIES, INCLUDING, BUT NOT LIMITED TO, THE IMPLIED WARRANTIES OF MERCHANTABILITY AND FITNESS FOR A PARTICULAR PURPOSE, WHICH ARE HEREBY DISCLAIMED. IN NO EVENT SHALL NETAPP BE LIABLE FOR ANY DIRECT, INDIRECT, INCIDENTAL, SPECIAL, EXEMPLARY, OR CONSEQUENTIAL DAMAGES (INCLUDING, BUT NOT LIMITED TO, PROCUREMENT OF SUBSTITUTE GOODS OR SERVICES; LOSS OF USE, DATA, OR PROFITS; OR BUSINESS INTERRUPTION) HOWEVER CAUSED AND ON ANY THEORY OF LIABILITY, WHETHER IN CONTRACT, STRICT LIABILITY, OR TORT (INCLUDING NEGLIGENCE OR OTHERWISE) ARISING IN ANY WAY OUT OF THE USE OF THIS SOFTWARE, EVEN IF ADVISED OF THE POSSIBILITY OF SUCH DAMAGE.

NetApp reserves the right to change any products described herein at any time, and without notice. NetApp assumes no responsibility or liability arising from the use of products described herein, except as expressly agreed to in writing by NetApp. The use or purchase of this product does not convey a license under any patent rights, trademark rights, or any other intellectual property rights of NetApp.

The product described in this manual may be protected by one or more U.S. patents, foreign patents, or pending applications.

LIMITED RIGHTS LEGEND: Use, duplication, or disclosure by the government is subject to restrictions as set forth in subparagraph (b)(3) of the Rights in Technical Data -Noncommercial Items at DFARS 252.227-7013 (FEB 2014) and FAR 52.227-19 (DEC 2007).

Data contained herein pertains to a commercial product and/or commercial service (as defined in FAR 2.101) and is proprietary to NetApp, Inc. All NetApp technical data and computer software provided under this Agreement is commercial in nature and developed solely at private expense. The U.S. Government has a non-exclusive, non-transferrable, nonsublicensable, worldwide, limited irrevocable license to use the Data only in connection with and in support of the U.S. Government contract under which the Data was delivered. Except as provided herein, the Data may not be used, disclosed, reproduced, modified, performed, or displayed without the prior written approval of NetApp, Inc. United States Government license rights for the Department of Defense are limited to those rights identified in DFARS clause 252.227-7015(b) (FEB 2014).

## Trademark information

NETAPP, the NETAPP logo, and the marks listed at <http://www.netapp.com/TM> are trademarks of NetApp, Inc. Other company and product names may be trademarks of their respective owners.