



Boot media - automated recovery

Install and maintain

NetApp
February 06, 2026

Table of Contents

- Boot media - automated recovery 1
 - Boot media automated recovery workflow - FAS500f 1
 - Requirements for automated boot media recovery - FAS500f 1
 - Shut down the controller for automated boot media recovery - FAS500f 2
 - Replace the boot media for automated boot recovery - FAS500f 3
 - Step 1: Remove the controller module 3
 - Step 2: Replace the boot media 6
 - Automated boot media recovery from the partner node - FAS500f 9
 - Return the failed boot media to NetApp - FAS500f 15

Boot media - automated recovery

Boot media automated recovery workflow - FAS500f

The automated recovery of the boot image involves the system automatically identifying and selecting the appropriate boot menu option. It uses the boot image on partner node to reinstall ONTAP on the replacement boot media in your FAS500f storage system.

The automated boot media recovery process is supported only in ONTAP 9.18.1 and later. If your storage system is running an earlier version of ONTAP, use the [manual boot recovery procedure](#).

To get started, review the replacement requirements, shut down the controller, replace the boot media, allow the system to restore the image, and verify system functionality.

1

Review the boot media requirements

Review the requirements for boot media replacement.

2

Shut down the controller

Shut down the controller in your storage system when when you need to replace the boot media.

3

Replace the boot media

Remove the failed boot media from the controller module and install the replacement boot media.

4

Restore the image on the boot media

Restore the ONTAP image from the partner controller.

5

Return the failed part to NetApp

Return the failed part to NetApp, as described in the RMA instructions shipped with the kit.

Requirements for automated boot media recovery - FAS500f

Before replacing the boot media in your FAS500f, ensure you meet the necessary requirements for a successful replacement. This includes verifying that you have the correct replacement boot media, confirming that the e0S (e0M wrench) port on the impaired controller is not faulty, and determining whether Onboard Key Manager (OKM) or External Key Manager (EKM) is enabled.

The automated boot media recovery process is supported only in ONTAP 9.18.1 and later. If your storage system is running an earlier version of ONTAP, use the [manual boot recovery procedure](#).

- You must replace the failed component with a replacement FRU component of the same capacity that you

received from NetApp.

- Verify that the e0M (wrench) port on the impaired controller is connected and not faulty.

The e0M port is used to communicate between the two controllers during the automated boot recovery process.

- For OKM, you need the cluster-wide passphrase and also the backup data.
- For EKM, you need copies of the following files from the partner node:
 - /cfcard/kmip/servers.cfg file.
 - /cfcard/kmip/certs/client.crt file.
 - /cfcard/kmip/certs/client.key file.
 - /cfcard/kmip/certs/CA.pem file.
- It is critical to apply the commands to the correct controller when you are replacing the impaired boot media:
 - The *impaired controller* is the controller on which you are performing maintenance.
 - The *healthy controller* is the HA partner of the impaired controller.

What's next

After you've reviewed the boot media requirements, you [shut down the controller](#).

Shut down the controller for automated boot media recovery - FAS500f

Shut down the impaired controller in your FAS500f storage system to prevent data loss and maintain system stability during the automated boot media recovery process.

The automated boot media recovery process is supported only in ONTAP 9.18.1 and later. If your storage system is running an earlier version of ONTAP, use the [manual boot recovery procedure](#).

To shut down the impaired controller, you must determine the status of the controller and, if necessary, take over the controller so that the healthy controller continues to serve data from the impaired controller storage.

About this task

- If you have a SAN system, you must have checked event messages (`cluster kernel-service show`) for the impaired controller SCSI blade. The `cluster kernel-service show` command (from `priv advanced` mode) displays the node name, [quorum status](#) of that node, availability status of that node, and operational status of that node.

Each SCSI-blade process should be in quorum with the other nodes in the cluster. Any issues must be resolved before you proceed with the replacement.

- If you have a cluster with more than two nodes, it must be in quorum. If the cluster is not in quorum or a healthy controller shows false for eligibility and health, you must correct the issue before shutting down the impaired controller; see [Synchronize a node with the cluster](#).

Steps

1. If AutoSupport is enabled, suppress automatic case creation by invoking an AutoSupport message:

```
system node autosupport invoke -node * -type all -message MAINT=<# of hours>h
```

The following AutoSupport message suppresses automatic case creation for two hours:

```
cluster1:> system node autosupport invoke -node * -type all -message MAINT=2h
```

2. Disable automatic giveback:

- a. Enter the following command from the console of the healthy controller:

```
storage failover modify -node impaired_node_name -auto-giveback false
```

- b. Enter `y` when you see the prompt *Do you want to disable auto-giveback?*

3. Take the impaired controller to the LOADER prompt:

If the impaired controller is displaying...	Then...
The LOADER prompt	Go to the next step.
Waiting for giveback...	Press Ctrl-C, and then respond <code>y</code> when prompted.
System prompt or password prompt	Take over or halt the impaired controller from the healthy controller: <pre>storage failover takeover -ofnode <i>impaired_node_name</i> -halt true</pre> The <code>-halt true</code> parameter brings you to the LOADER prompt.

What's next

After you shut down the impaired controller, you [replace the boot media](#).

Replace the boot media for automated boot recovery - FAS500f

The boot media in your FAS500f system stores essential firmware and configuration data. The replacement process involves removing and opening the controller module, removing the impaired boot media, installing the replacement boot media in the controller module, and then reinstalling the controller module.

The automated boot media recovery process is supported only in ONTAP 9.18.1 and later. If your storage system is running an earlier version of ONTAP, use the [manual boot recovery procedure](#).

The boot media is located inside the controller module under the air duct, and is accessed by removing the controller module from the system.

Step 1: Remove the controller module

1. If you are not already grounded, properly ground yourself.

2. Unplug the controller module power supplies from the source.
3. Release the power cable retainers, and then unplug the cables from the power supplies.
4. Unplug the I/O cables from the controller module.
5. Insert your forefinger into the latching mechanism on either side of the controller module, press the lever with your thumb, and gently pull the controller a few inches out of the chassis.



If you have difficulty removing the controller module, place your index fingers through the finger holes from the inside (by crossing your arms).

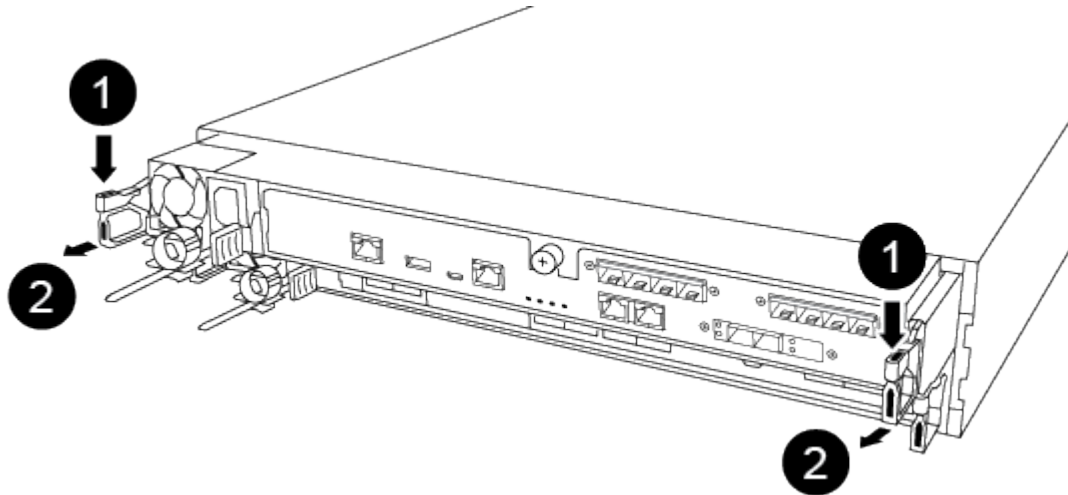

1	Lever
2	Latching mechanism

6. Using both hands, grasp the controller module sides and gently pull it out of the chassis and set it on a flat, stable surface.
7. Turn the thumbscrew on the front of the controller module anti-clockwise and open the controller module cover.

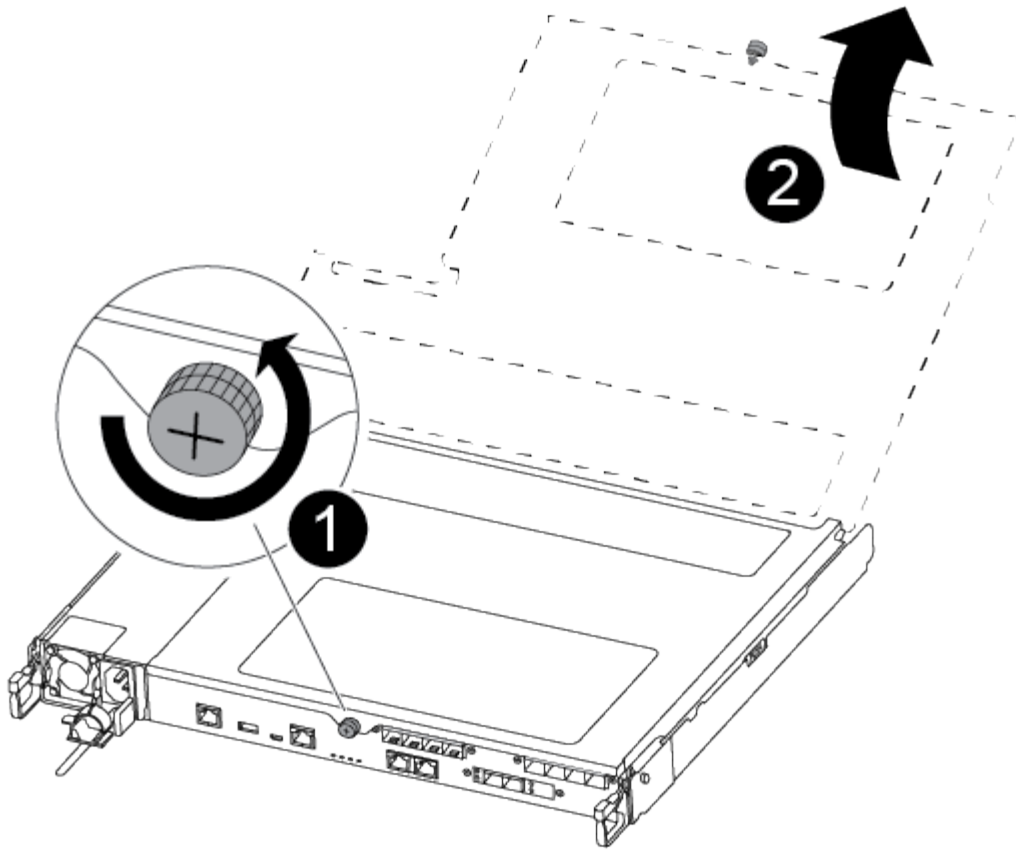

1	Thumbscrew
2	Controller module cover.

8. Lift out the air duct cover.

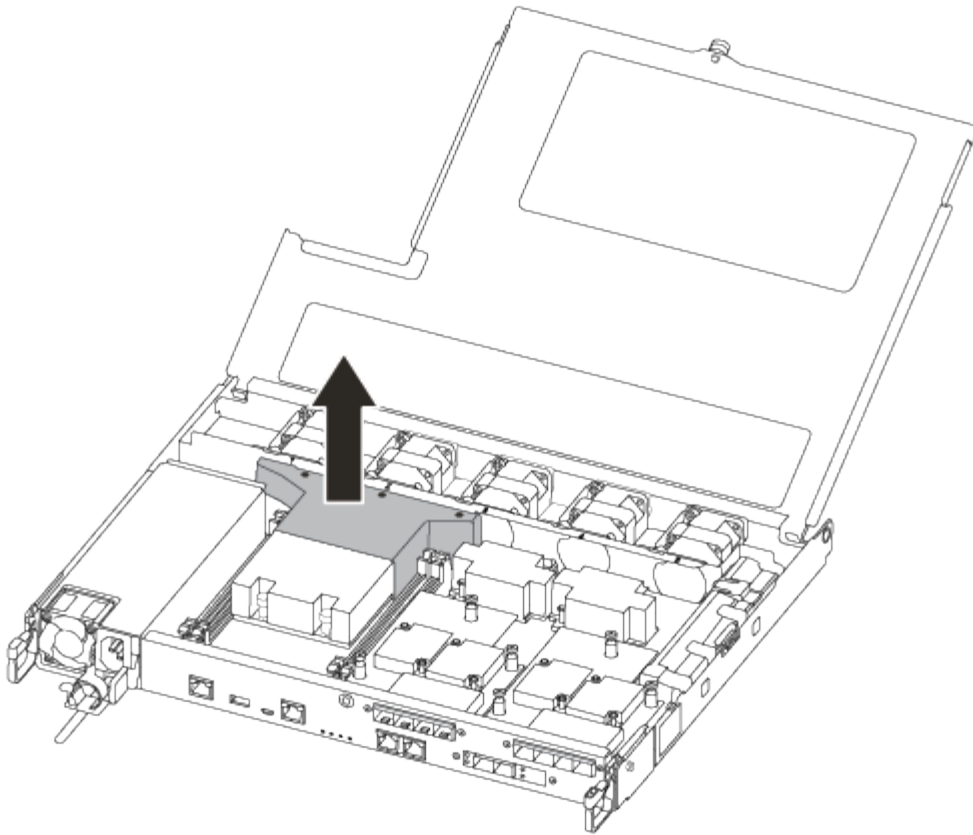

Step 2: Replace the boot media

You can use the following video or the tabulated steps to replace the boot media:

[Animation - Replace the boot media](#)

1. Locate and replace the impaired boot media from the controller module and replace it:



You need a #1 magnetic Phillips head screwdriver to remove the screw that holds the boot media in place. Due to the space constraints within the controller module, you should also have a magnet to transfer the screw on to so that you do not lose it.

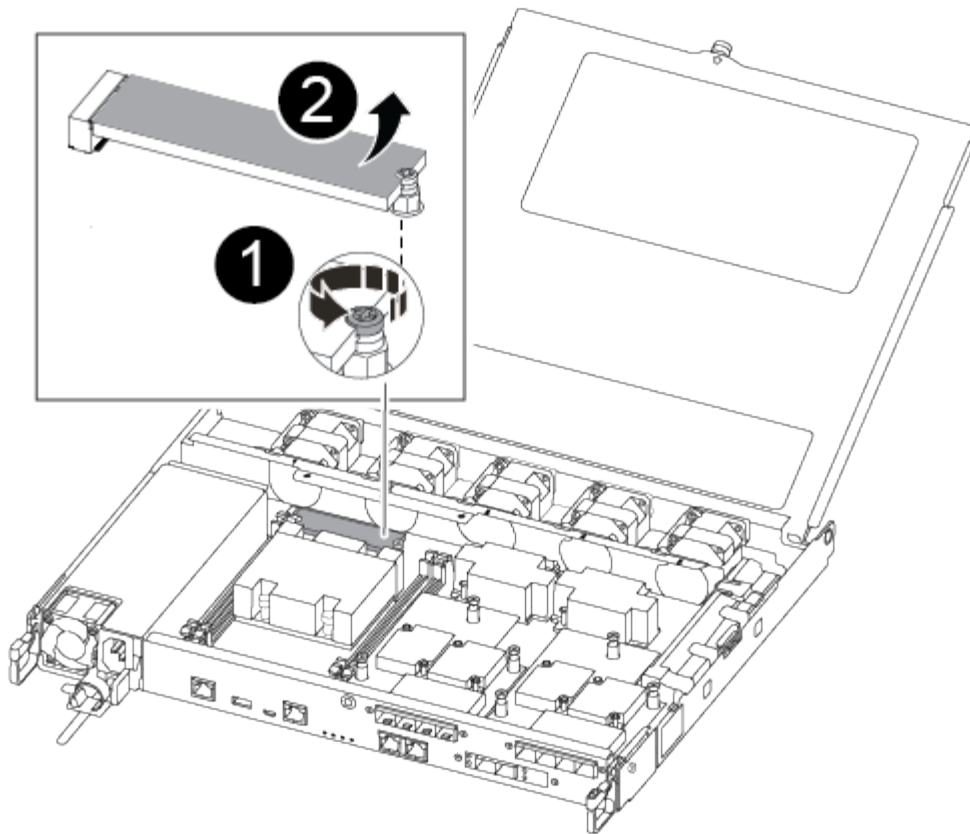

<p>1</p>	<p>Remove the screw securing the boot media to the motherboard in the controller module.</p>
<p>2</p>	<p>Lift the boot media out of the controller module.</p>

- a. Using the #1 magnetic screwdriver, remove the screw from the impaired boot media, and set it aside safely on the magnet.
- b. Gently lift the impaired boot media directly out of the socket and set it aside.
- c. Remove the replacement boot media from the antistatic shipping bag and align it into place on the controller module.
- d. Using the #1 magnetic screwdriver, insert and tighten the screw on the boot media.

Do not over-tighten the screw or you might damage the boot media.

- e. Install the air duct.

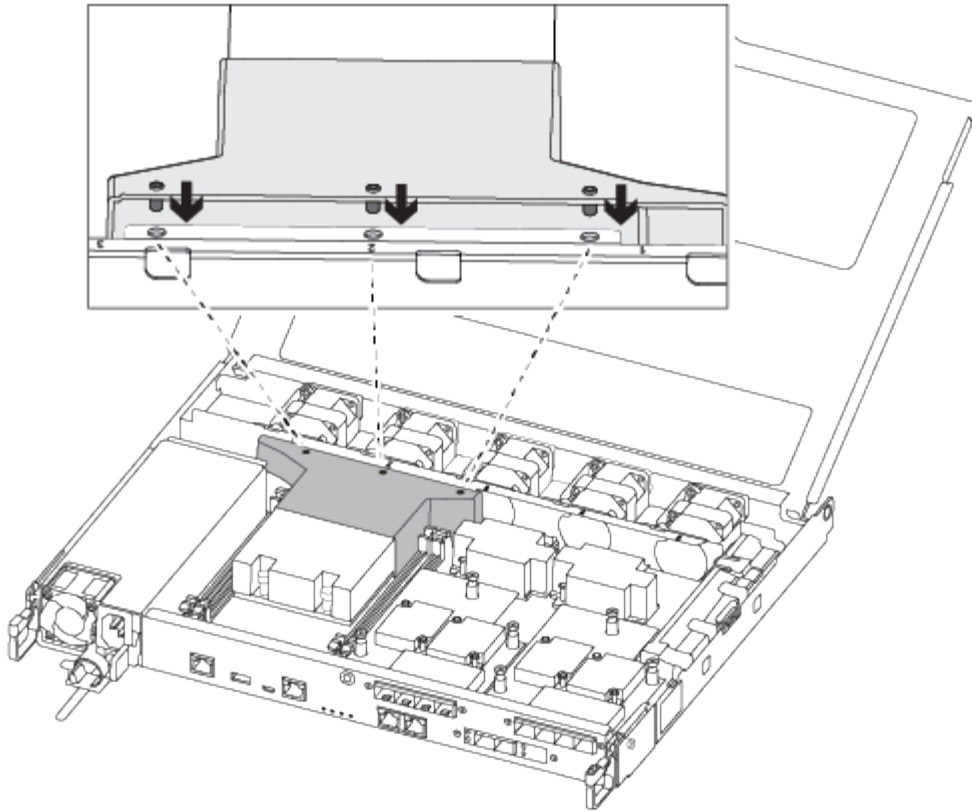

f. Close the controller module cover and tighten the thumbscrew.

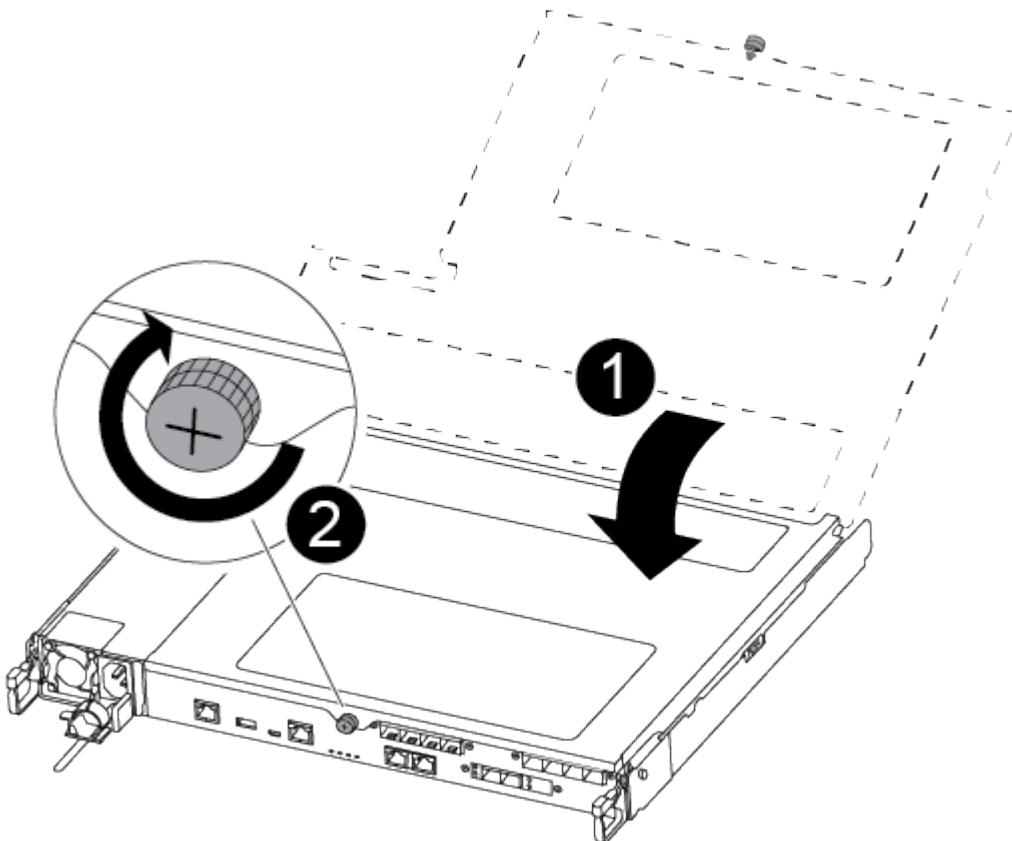

1	Controller module cover
2	Thumbscrew

2. Install the controller module:

- a. Align the end of the controller module with the opening in the chassis, and then gently push the controller module halfway into the system.
- b. Push the controller module all the way into the chassis:
- c. Place your index fingers through the finger holes from the inside of the latching mechanism.
- d. Press your thumbs down on the orange tabs on top of the latching mechanism and gently push the controller module over the stop.
- e. Release your thumbs from the top of the latching mechanisms and continue pushing until the latching mechanisms snap into place.

The controller module should be fully inserted and flush with the edges of the chassis.

3. Reconnect the controller module I/O cables.

4. Plug the power cords into the power supplies, reinstall the power cable locking collar, and then connect the power supplies to the power source.

The controller module begins to boot and stops at the LOADER prompt.

What's next

After physically replacing the impaired boot media, [restore the ONTAP image from the partner node](#).

Automated boot media recovery from the partner node - FAS500f

After installing the new boot media device in your FAS500f system, you can start the automated boot media recovery process to restore the configuration from the partner node. During the recovery process, the system checks whether encryption is enabled and determines the type of key encryption in use. If key encryption is enabled, the system guides you through the appropriate steps to restore it.

The automated boot media recovery process is supported only in ONTAP 9.18.1 and later. If your storage system is running an earlier version of ONTAP, use the [manual boot recovery procedure](#).

Before you begin

- Determine your key manager type:
 - Onboard Key Manager (OKM): Requires cluster-wide passphrase and backup data
 - External Key Manager (EKM): Requires the following files from the partner node:
 - /cfcard/knip/servers.cfg
 - /cfcard/knip/certs/client.crt

- /cfcard/knip/certs/client.key
- /cfcard/knip/certs/CA.pem

Steps

1. From the LOADER prompt, start the boot media recovery process:

```
boot_recovery -partner
```

The screen displays the following message:

```
Starting boot media recovery (BMR) process. Press Ctrl-C to abort...
```

2. Monitor the boot media install recovery process.

The process completes and displays the `Installation complete` message.

3. The system checks for encryption and displays one of the following messages:

If you see this message...	Do this...
key manager is not configured. Exiting.	<p>Encryption is not installed on the system.</p> <ol style="list-style-type: none"> a. Wait for the login prompt to display. b. Log into the node and give back the storage: <pre>storage failover giveback -ofnode impaired_node_name</pre> c. Go to re-enabling automatic giveback if it was disabled.
key manager is configured.	Encryption is installed. Go to restoring the key manager .



If the system cannot identify the key manager configuration, it displays an error message and prompts you to confirm whether key manager is configured and which type (onboard or external). Answer the prompts to proceed.

4. Restore the key manager using the appropriate procedure for your configuration:

Onboard Key Manager (OKM)

The system displays the following message and begins running BootMenu Option 10:

```
key manager is configured.  
Entering Bootmenu Option 10...  
  
This option must be used only in disaster recovery procedures. Are  
you sure? (y or n):
```

- a. Enter `y` at the prompt to confirm you want to start the OKM recovery process.
- b. Enter the passphrase for onboard key management when prompted.
- c. Enter the passphrase again when prompted to confirm.
- d. Enter the backup data for onboard key manager when prompted.

Show example of passphrase and backup data prompts

```
Enter the passphrase for onboard key management:  
-----BEGIN PASSPHRASE-----  
<passphrase_value>  
-----END PASSPHRASE-----  
Enter the passphrase again to confirm:  
-----BEGIN PASSPHRASE-----  
<passphrase_value>  
-----END PASSPHRASE-----  
Enter the backup data:  
-----BEGIN BACKUP-----  
<passphrase_value>  
-----END BACKUP-----
```

- e. Monitor the recovery process as it restores the appropriate files from the partner node.

When the recovery process is complete, the node reboots. The following messages indicate a successful recovery:

```
Trying to recover keymanager secrets....  
Setting recovery material for the onboard key manager  
Recovery secrets set successfully  
Trying to delete any existing km_onboard.keydb file.  
  
Successfully recovered keymanager secrets.
```

- f. After the node reboots, verify that the system is back online and operational.

- g. Return the impaired controller to normal operation by giving back its storage:

```
storage failover giveback -ofnode impaired_node_name
```

- h. After the partner node is fully up and serving data, synchronize the OKM keys across the cluster:

```
security key-manager onboard sync
```

Go to [re-enabling automatic giveback](#) if it was disabled.

External Key Manager (EKM)

The system displays the following message and begins running BootMenu Option 11:

```
key manager is configured.  
Entering Bootmenu Option 11...
```

- a. Enter the EKM configuration settings when prompted:

- i. Enter the client certificate contents from the `/cfcard/kmip/certs/client.crt` file:

Show example of client certificate contents

```
-----BEGIN CERTIFICATE-----  
<certificate_value>  
-----END CERTIFICATE-----
```

- ii. Enter the client key file contents from the `/cfcard/kmip/certs/client.key` file:

Show example of client key file contents

```
-----BEGIN RSA PRIVATE KEY-----  
<key_value>  
-----END RSA PRIVATE KEY-----
```

- iii. Enter the KMIP server CA(s) file contents from the `/cfcard/kmip/certs/CA.pem` file:

Show example of KMIP server file contents

```
-----BEGIN CERTIFICATE-----  
<KMIP_certificate_CA_value>  
-----END CERTIFICATE-----
```

- iv. Enter the server configuration file contents from the `/cfcard/kmip/servers.cfg` file:

Show example of server configuration file contents

```
xxx.xxx.xxx.xxx:5696.host=xxx.xxx.xxx.xxx
xxx.xxx.xxx.xxx:5696.port=5696
xxx.xxx.xxx.xxx:5696.trusted_file=/cfcard/kmip/certs/CA.pem
xxx.xxx.xxx.xxx:5696.protocol=KMIP1_4
1xxx.xxx.xxx.xxx:5696.timeout=25
xxx.xxx.xxx.xxx:5696.nbio=1
xxx.xxx.xxx.xxx:5696.cert_file=/cfcard/kmip/certs/client.c
r
t
xxx.xxx.xxx.xxx:5696.key_file=/cfcard/kmip/certs/client.key
xxx.xxx.xxx.xxx:5696.ciphers="TLSv1.2:kRSA:!CAMELLIA:!IDEA:
!RC2:!RC4:!SEED:!eNULL:!aNULL"
xxx.xxx.xxx.xxx:5696.verify=true
xxx.xxx.xxx.xxx:5696.netapp_keystore_uuid=<id_value>
```

- v. If prompted, enter the ONTAP Cluster UUID from the partner node. You can check the cluster UUID from the partner node using the `cluster identify show` command.

Show example of ONTAP Cluster UUID prompt

```
Notice: bootarg.mgwd.cluster_uuid is not set or is empty.
Do you know the ONTAP Cluster UUID? {y/n} y
Enter the ONTAP Cluster UUID: <cluster_uuid_value>

System is ready to utilize external key manager(s).
```

- vi. If prompted, enter the temporary network interface and settings for the node:

- The IP address for the port
- The netmask for the port
- The IP address of the default gateway

Show example of temporary network setting prompts

In order to recover key information, a temporary network interface needs to be configured.

Select the network port you want to use (for example, 'e0a')
e0M

Enter the IP address for port : xxx.xxx.xxx.xxx

Enter the netmask for port : xxx.xxx.xxx.xxx

Enter IP address of default gateway: xxx.xxx.xxx.xxx

Trying to recover keys from key servers....

[discover_versions]

[status=SUCCESS reason= message=]

b. Verify the key restoration status:

- If you see `kmip2_client: Successfully imported the keys from external key server: xxx.xxx.xxx.xxx:5696` in the output, the EKM configuration has been successfully restored. The process restores the appropriate files from the partner node and reboots the node. Proceed to the next step.
- If the key is not successfully restored, the system halts and displays error and warning messages. Rerun the recovery process from the LOADER prompt: `boot_recovery -partner`

Show example of key recovery error and warning messages

```
ERROR: kmip_init: halting this system with encrypted
mroot...
WARNING: kmip_init: authentication keys might not be
available.
*****
*                A T T E N T I O N                *
*                                                    *
*          System cannot connect to key managers.          *
*                                                    *
*****
ERROR: kmip_init: halting this system with encrypted
mroot...
.
Terminated

Uptime: 11m32s
System halting...

LOADER-B>
```

- c. After the node reboots, verify that the system is back online and operational.
- d. Return the controller to normal operation by giving back its storage:

```
storage failover giveback -ofnode impaired_node_name
```

Go to [re-enabling automatic giveback](#) if it was disabled.

5. If automatic giveback was disabled, reenable it:

```
storage failover modify -node local -auto-giveback true
```

6. If AutoSupport is enabled, restore automatic case creation:

```
system node autosupport invoke -node * -type all -message MAINT=END
```

What's next

After you've restored the ONTAP image and the node is up and serving data, you [return the failed part to NetApp](#).

Return the failed boot media to NetApp - FAS500f

If a component in your FAS500f system fails, return the failed part to NetApp. See the

[Part Return and Replacements](#) page for further information.

Copyright information

Copyright © 2026 NetApp, Inc. All Rights Reserved. Printed in the U.S. No part of this document covered by copyright may be reproduced in any form or by any means—graphic, electronic, or mechanical, including photocopying, recording, taping, or storage in an electronic retrieval system—without prior written permission of the copyright owner.

Software derived from copyrighted NetApp material is subject to the following license and disclaimer:

THIS SOFTWARE IS PROVIDED BY NETAPP “AS IS” AND WITHOUT ANY EXPRESS OR IMPLIED WARRANTIES, INCLUDING, BUT NOT LIMITED TO, THE IMPLIED WARRANTIES OF MERCHANTABILITY AND FITNESS FOR A PARTICULAR PURPOSE, WHICH ARE HEREBY DISCLAIMED. IN NO EVENT SHALL NETAPP BE LIABLE FOR ANY DIRECT, INDIRECT, INCIDENTAL, SPECIAL, EXEMPLARY, OR CONSEQUENTIAL DAMAGES (INCLUDING, BUT NOT LIMITED TO, PROCUREMENT OF SUBSTITUTE GOODS OR SERVICES; LOSS OF USE, DATA, OR PROFITS; OR BUSINESS INTERRUPTION) HOWEVER CAUSED AND ON ANY THEORY OF LIABILITY, WHETHER IN CONTRACT, STRICT LIABILITY, OR TORT (INCLUDING NEGLIGENCE OR OTHERWISE) ARISING IN ANY WAY OUT OF THE USE OF THIS SOFTWARE, EVEN IF ADVISED OF THE POSSIBILITY OF SUCH DAMAGE.

NetApp reserves the right to change any products described herein at any time, and without notice. NetApp assumes no responsibility or liability arising from the use of products described herein, except as expressly agreed to in writing by NetApp. The use or purchase of this product does not convey a license under any patent rights, trademark rights, or any other intellectual property rights of NetApp.

The product described in this manual may be protected by one or more U.S. patents, foreign patents, or pending applications.

LIMITED RIGHTS LEGEND: Use, duplication, or disclosure by the government is subject to restrictions as set forth in subparagraph (b)(3) of the Rights in Technical Data -Noncommercial Items at DFARS 252.227-7013 (FEB 2014) and FAR 52.227-19 (DEC 2007).

Data contained herein pertains to a commercial product and/or commercial service (as defined in FAR 2.101) and is proprietary to NetApp, Inc. All NetApp technical data and computer software provided under this Agreement is commercial in nature and developed solely at private expense. The U.S. Government has a non-exclusive, non-transferrable, nonsublicensable, worldwide, limited irrevocable license to use the Data only in connection with and in support of the U.S. Government contract under which the Data was delivered. Except as provided herein, the Data may not be used, disclosed, reproduced, modified, performed, or displayed without the prior written approval of NetApp, Inc. United States Government license rights for the Department of Defense are limited to those rights identified in DFARS clause 252.227-7015(b) (FEB 2014).

Trademark information

NETAPP, the NETAPP logo, and the marks listed at <http://www.netapp.com/TM> are trademarks of NetApp, Inc. Other company and product names may be trademarks of their respective owners.