



Prepare to add a local tier (aggregate)

ONTAP 9

NetApp
December 01, 2022

Table of Contents

- Prepare to add a local tier (aggregate) 1
- Prepare to add a local tier (aggregate) 1
- Local tiers (aggregates) and RAID groups 1
- Mirrored and unmirrored local tiers (aggregates) 1
- Fast zeroing of drives 4
- Manually assign disk ownership 5

Prepare to add a local tier (aggregate)

Prepare to add a local tier (aggregate)

Before you add a local tier, you should understand the following topics:

- Learn about RAID groups, RAID protection levels, and RAID policies for local tiers.
 - [Local tiers \(aggregates\) and RAID groups](#)
- Learn about mirrored and unmirrored local tiers and how to quickly zero drives before provisioning them.
 - [Mirrored and unmirrored local tiers \(aggregates\)](#)
 - [Fast zeroing of drives](#)
- Perform a manual assignment of disk ownership before provisioning a local tier.
 - [Manually assign disk ownership](#)

Local tiers (aggregates) and RAID groups

Modern RAID technologies protect against disk failure by rebuilding a failed disk's data on a spare disk. The system compares index information on a "parity disk" with data on the remaining healthy disks to reconstruct the missing data, all without downtime or a significant performance cost.

A local tier (aggregate) consists of one or more *RAID groups*. The *RAID type* of the local tier determines the number of parity disks in the RAID group and the number of simultaneous disk failures that the RAID configuration protects against.

The default RAID type, RAID-DP (RAID-double parity), requires two parity disks per RAID group and protects against data loss in the event of two disks failing at the same time. For RAID-DP, the recommended RAID group size is between 12 and 20 HDDs and between 20 and 28 SSDs.

You can spread out the overhead cost of parity disks by creating RAID groups at the higher end of the sizing recommendation. This is especially the case for SSDs, which are much more reliable than capacity drives. For local tiers that use HDDs, you should balance the need to maximize disk storage against countervailing factors like the longer rebuild time required for larger RAID groups.

Mirrored and unmirrored local tiers (aggregates)

ONTAP has an optional feature called *SyncMirror* which you can use to synchronously mirror local tier (aggregate) data in copies, or *plexes*, stored in different RAID groups. Plexes ensure against data loss if more disks fail than the RAID type protects against, or if there is a loss of connectivity to RAID group disks.

When you create a local tier with System Manager or using the CLI, you can specify that the local tier is mirrored or unmirrored.

How unmirrored local tiers (aggregates) work

If you do not specify that the local tiers are mirrored, then they are created as unmirrored local tiers

(aggregates). Unmirrored local tiers have only one *plex* (a copy of their data), which contains all of the RAID groups belonging to that local tier.

The following diagram shows an unmirrored local tier composed of disks, with its one plex. The local tier has four RAID groups: rg0, rg1, rg2, and rg3. Each RAID group has six data disks, one parity disk, and one dparity (double parity) disk. All disks used by the local tier come from the same pool, "pool0".

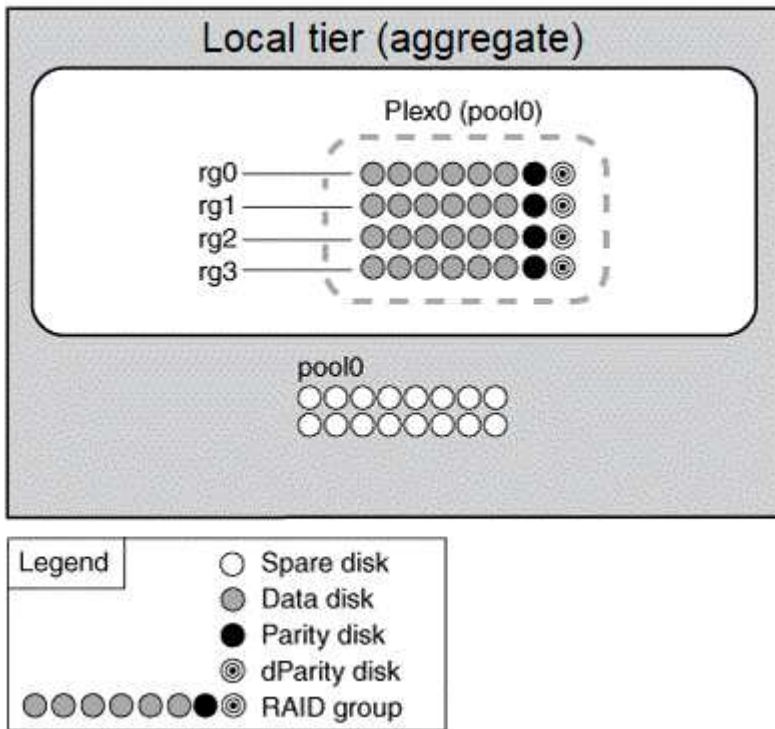

The following diagram shows an unmirrored local tier with array LUNs, with its one plex. It has two RAID groups, rg0 and rg1. All array LUNs used by the local tier come from the same pool, "pool0".

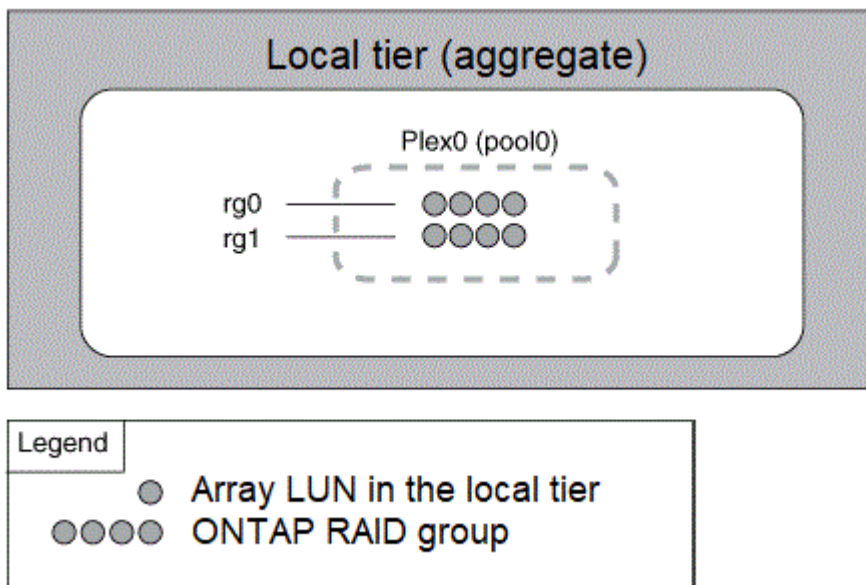

How mirrored local tiers (aggregates) work

Mirrored aggregates have two *plexes* (copies of their data), which use the SyncMirror functionality to duplicate the data to provide redundancy.

When you create a local tier, you can specify that it is a mirrored local tier. Also, you can add a second plex to an existing unmirrored local tier to make it a mirrored tier. Using SyncMirror functionality, ONTAP copies the data in the original plex (plex0) to the new plex (plex1). The plexes are physically separated (each plex has its own RAID groups and its own pool), and the plexes are updated simultaneously.

This configuration provides added protection against data loss if more disks fail than the RAID level of the aggregate protects against or if there is a loss of connectivity, because the unaffected plex continues to serve data while you fix the cause of the failure. After the plex that had a problem is fixed, the two plexes resynchronize and reestablish the mirror relationship.

The disks and array LUNs on the system are divided into two pools: “pool0” and “pool1”. Plex0 gets its storage from pool0 and plex1 gets its storage from pool1.

The following diagram shows a local tier composed of disks with the SyncMirror functionality enabled and implemented. A second plex has been created for the local tier, “plex1”. The data in plex1 is a copy of the data in plex0, and the RAID groups are also identical. The 32 spare disks are allocated to pool0 or pool1 using 16 disks for each pool.

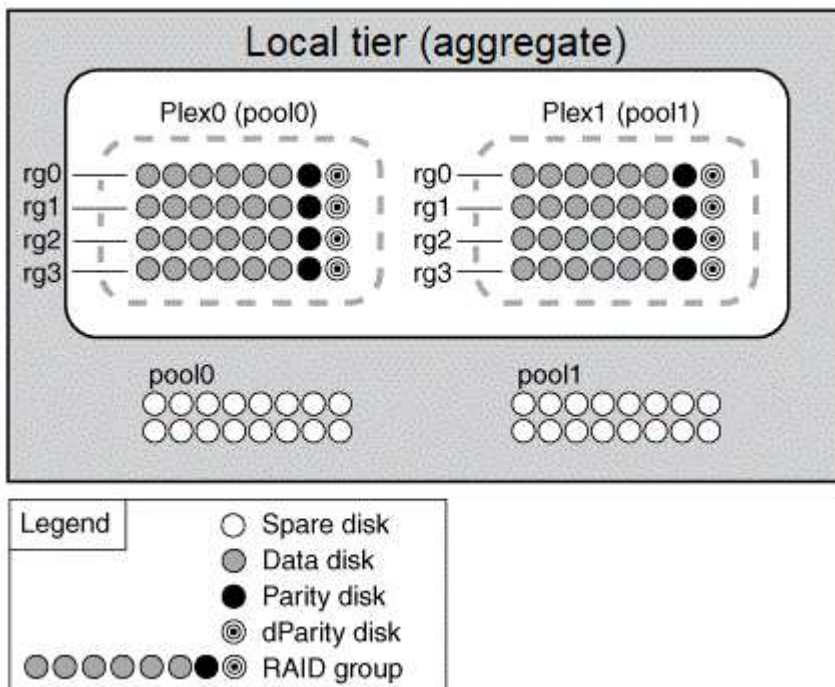

The following diagram shows an local tier composed of array LUNs with the SyncMirror functionality enabled and implemented. A second plex has been created for the local tier, “plex1”. Plex1 is a copy of plex0, and the RAID groups are also identical.

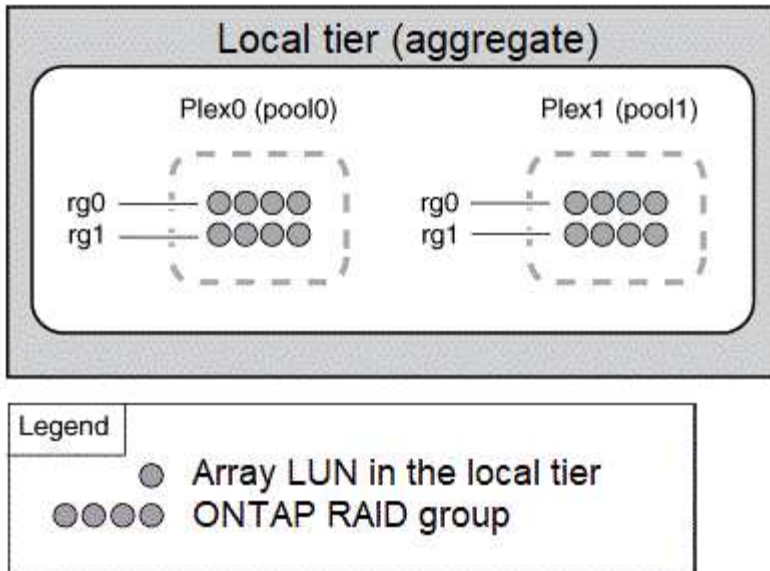

Fast zeroing of drives

Beginning with ONTAP 9.4, you can automatically and quickly zero drives (both SSDs and HDDs) before provisioning without experiencing long wait times.

For systems that are freshly installed with ONTAP 9.4 or later or systems that are reinitialized with ONTAP 9.4 or later, drive zeroing takes place automatically and is completed in seconds.

If you need to manually zero a drive, you can use one of the following methods:

CLI command

Use a CLI command to fast-zero drives

About this task

Admin privileges are required to use this command.

Steps

1. Enter the CLI command:

```
storage disk zerospares
```

Boot menu options

Select options from the boot menu to fast-zero drives

About this task

- The fast zeroing enhancement does not support systems upgraded from a release earlier than ONTAP 9.4.
- If any node on the cluster contains a local tier (aggregate) with fast-zeroed drives, then you cannot revert the cluster to ONTAP 9.2 or earlier.

Steps

1. From the boot menu, select one of the following options:
 - (4) Clean configuration and initialize all disks
 - (9a) Unpartition all disks and remove their ownership information
 - (9b) Clean configuration and initialize node with whole disks

Manually assign disk ownership

Disks must be owned by a node before they can be used in a local tier (aggregate).

If your cluster is not configured to use automatic disk ownership assignment, you must assign ownership manually.

You cannot reassign ownership of a disk that is in use in a local tier.

Steps

1. Using the CLI, display all unowned disks:

```
storage disk show -container-type unassigned
```

2. Assign each disk:

```
storage disk assign -disk disk_name -owner owner_name
```

You can use the wildcard character to assign more than one disk at once. If you are reassigning a spare disk that is already owned by a different node, you must use the “-force” option.

Copyright information

Copyright © 2022 NetApp, Inc. All Rights Reserved. Printed in the U.S. No part of this document covered by copyright may be reproduced in any form or by any means—graphic, electronic, or mechanical, including photocopying, recording, taping, or storage in an electronic retrieval system—without prior written permission of the copyright owner.

Software derived from copyrighted NetApp material is subject to the following license and disclaimer:

THIS SOFTWARE IS PROVIDED BY NETAPP “AS IS” AND WITHOUT ANY EXPRESS OR IMPLIED WARRANTIES, INCLUDING, BUT NOT LIMITED TO, THE IMPLIED WARRANTIES OF MERCHANTABILITY AND FITNESS FOR A PARTICULAR PURPOSE, WHICH ARE HEREBY DISCLAIMED. IN NO EVENT SHALL NETAPP BE LIABLE FOR ANY DIRECT, INDIRECT, INCIDENTAL, SPECIAL, EXEMPLARY, OR CONSEQUENTIAL DAMAGES (INCLUDING, BUT NOT LIMITED TO, PROCUREMENT OF SUBSTITUTE GOODS OR SERVICES; LOSS OF USE, DATA, OR PROFITS; OR BUSINESS INTERRUPTION) HOWEVER CAUSED AND ON ANY THEORY OF LIABILITY, WHETHER IN CONTRACT, STRICT LIABILITY, OR TORT (INCLUDING NEGLIGENCE OR OTHERWISE) ARISING IN ANY WAY OUT OF THE USE OF THIS SOFTWARE, EVEN IF ADVISED OF THE POSSIBILITY OF SUCH DAMAGE.

NetApp reserves the right to change any products described herein at any time, and without notice. NetApp assumes no responsibility or liability arising from the use of products described herein, except as expressly agreed to in writing by NetApp. The use or purchase of this product does not convey a license under any patent rights, trademark rights, or any other intellectual property rights of NetApp.

The product described in this manual may be protected by one or more U.S. patents, foreign patents, or pending applications.

LIMITED RIGHTS LEGEND: Use, duplication, or disclosure by the government is subject to restrictions as set forth in subparagraph (b)(3) of the Rights in Technical Data -Noncommercial Items at DFARS 252.227-7013 (FEB 2014) and FAR 52.227-19 (DEC 2007).

Data contained herein pertains to a commercial product and/or commercial service (as defined in FAR 2.101) and is proprietary to NetApp, Inc. All NetApp technical data and computer software provided under this Agreement is commercial in nature and developed solely at private expense. The U.S. Government has a non-exclusive, non-transferrable, nonsublicensable, worldwide, limited irrevocable license to use the Data only in connection with and in support of the U.S. Government contract under which the Data was delivered. Except as provided herein, the Data may not be used, disclosed, reproduced, modified, performed, or displayed without the prior written approval of NetApp, Inc. United States Government license rights for the Department of Defense are limited to those rights identified in DFARS clause 252.227-7015(b) (FEB 2014).

Trademark information

NETAPP, the NETAPP logo, and the marks listed at <http://www.netapp.com/TM> are trademarks of NetApp, Inc. Other company and product names may be trademarks of their respective owners.