



# Maintaining the appliance

## StorageGRID 11.5

NetApp  
August 30, 2024

# Table of Contents

- Maintaining the appliance . . . . . 1
  - Placing an appliance into maintenance mode . . . . . 1
  - Turning the controller identify LED on and off . . . . . 4
  - Locating the controller in a data center . . . . . 6
  - Replacing the services appliance . . . . . 7
  - Replacing a power supply in the services appliance . . . . . 9
  - Replacing a fan in the services appliance . . . . . 10
  - Replacing a drive in the services appliance . . . . . 13
  - Changing the link configuration of the services appliance . . . . . 14
  - Changing the MTU setting . . . . . 16
  - Checking the DNS server configuration . . . . . 18
  - Monitoring node encryption in maintenance mode . . . . . 21

# Maintaining the appliance

You might need to perform maintenance procedures on the appliance. The procedures in this section assume that the appliance has already been deployed as a Gateway Node or an Admin Node in a StorageGRID system.

## Steps

- [Placing an appliance into maintenance mode](#)
- [Turning the controller identify LED on and off](#)
- [Locating the controller in a data center](#)
- [Replacing the services appliance](#)
- [Replacing a power supply in the services appliance](#)
- [Replacing a fan in the services appliance](#)
- [Replacing a drive in the services appliance](#)
- [Changing the link configuration of the services appliance](#)
- [Changing the MTU setting](#)
- [Checking the DNS server configuration](#)
- [Monitoring node encryption in maintenance mode](#)

## Placing an appliance into maintenance mode

You must place the appliance into maintenance mode before performing specific maintenance procedures.

### What you'll need

- You must be signed in to the Grid Manager using a supported browser.
- You must have the Maintenance or Root Access permission. For details, see the instructions for administering StorageGRID.

### About this task

Placing a StorageGRID appliance into maintenance mode might make the appliance unavailable for remote access.



The password and host key for a StorageGRID appliance in maintenance mode remain the same as they were when the appliance was in service.

## Steps

1. From the Grid Manager, select **Nodes**.
2. From the tree view of the Nodes page, select the appliance Storage Node.
3. Select **Tasks**.

## Reboot

Shuts down and restarts the node.

Reboot

## Maintenance Mode

Places the appliance's compute controller into maintenance mode.

Maintenance Mode

#### 4. Select **Maintenance Mode**.

A confirmation dialog box appears.

### Enter Maintenance Mode on SGA-106-15

You must place the appliance's compute controller into maintenance mode to perform certain maintenance procedures on the appliance.

Attention: All StorageGRID services on this node will be shut down. Wait a few minutes for the node to reboot into maintenance mode.

If you are ready to start, enter the provisioning passphrase and click OK.

Provisioning Passphrase

Cancel

OK

#### 5. Enter the provisioning passphrase, and select **OK**.

A progress bar and a series of messages, including "Request Sent," "Stopping StorageGRID," and "Rebooting," indicate that the appliance is completing the steps for entering maintenance mode.

## Reboot

Shuts down and restarts the node.

Reboot

## Maintenance Mode

**Attention:** Your request has been sent, but the appliance might take 10-15 minutes to enter maintenance mode. Do not perform maintenance procedures until this tab indicates maintenance mode is ready, or data could become corrupted.



Request Sent

When the appliance is in maintenance mode, a confirmation message lists the URLs you can use to access the StorageGRID Appliance Installer.

## Reboot

Shuts down and restarts the node.

Reboot

## Maintenance Mode

This node is currently in maintenance mode. Navigate to one of the URLs listed below and perform any necessary maintenance procedures.

- <https://172.16.2.106:8443>
- <https://10.224.2.106:8443>
- <https://47.47.2.106:8443>
- <https://169.254.0.1:8443>

When you are done with any required maintenance procedures, you must exit maintenance mode by clicking Reboot Controller from the StorageGRID Appliance Installer.

6. To access the StorageGRID Appliance Installer, browse to any of the URLs displayed.

If possible, use the URL containing the IP address of the appliance's Admin Network port.



Accessing <https://169.254.0.1:8443> requires a direct connection to the local management port.

7. From the StorageGRID Appliance Installer, confirm that the appliance is in maintenance mode.

⚠ This node is in maintenance mode. Perform any required maintenance procedures. If you want to exit maintenance mode manually to resume normal operation, go to **Advanced > Reboot Controller** to **reboot** the controller.

8. Perform any required maintenance tasks.
9. After completing maintenance tasks, exit maintenance mode and resume normal node operation. From the StorageGRID Appliance Installer, select **Advanced > Reboot Controller**, and then select **Reboot into StorageGRID**.

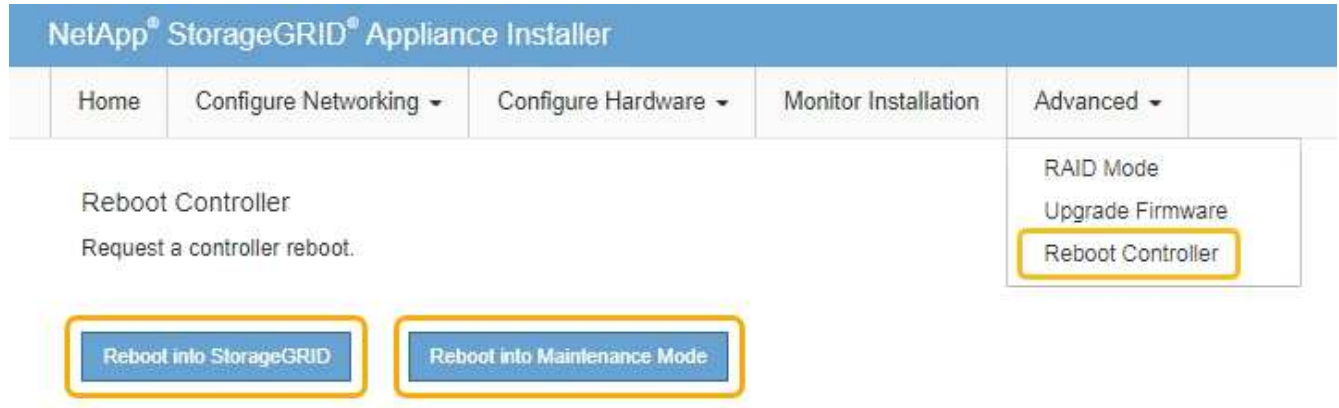

It can take up to 20 minutes for the appliance to reboot and rejoin the grid. To confirm that the reboot is complete and that the node has rejoined the grid, go back to the Grid Manager. The **Nodes** tab should display a normal status ✓ for the appliance node, indicating that no alerts are active and the node is connected to the grid.

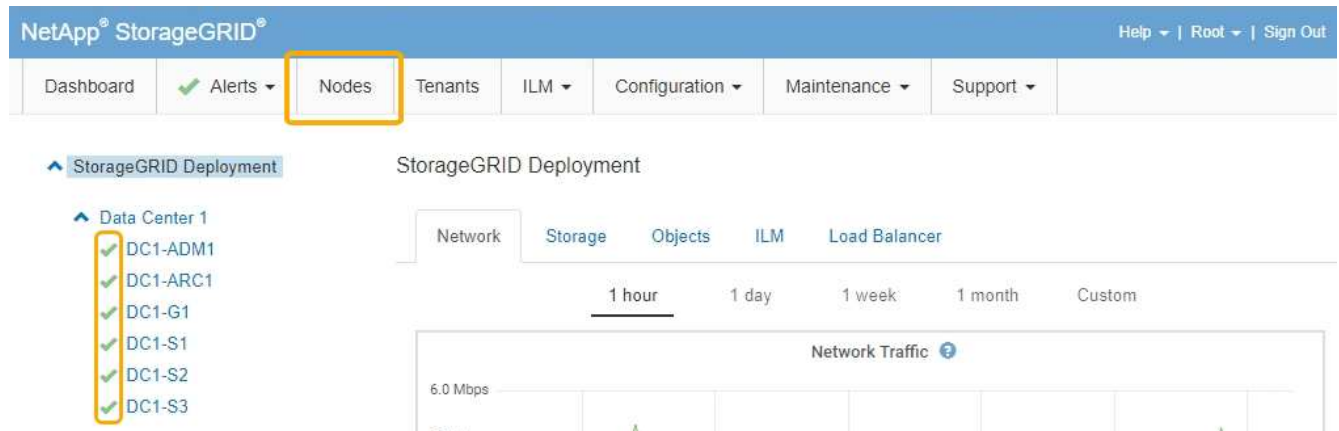

## Turning the controller identify LED on and off

The blue identify LED on the front and back of the controller can be turned on to help locate the appliance in a data center.

### What you'll need

You must have the BMC IP address of the controller you want to identify.

### Steps

1. Access the controller BMC interface.
2. Select **Server Identify**.
3. Select **ON** and then select **Perform Action**.

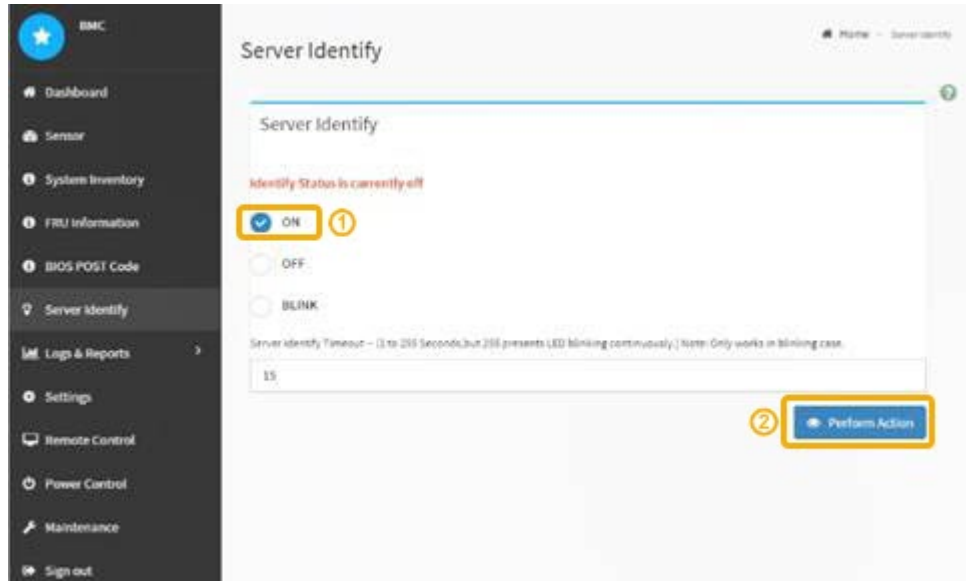

## Result

The blue identify LEDs light on the front (shown) and rear of the controller.



If a bezel is installed on the controller, it might be difficult to see the front identify LED.

## After you finish

To turn off the controller identify LED:

- Press the identify LED switch on the controller front panel.
- From the controller BMC interface, select **Server Identify**, select **OFF** and then select **Perform Action**.

The blue identify LEDs on the front and rear of the controller go off.





#### Related information

[Locating the controller in a data center](#)

[Accessing the BMC interface](#)

## Locating the controller in a data center

Locate the controller so that you can perform hardware maintenance or upgrades.

#### What you'll need

- You have determined which controller requires maintenance.

(Optional) To help locate the controller in your data center, turn on the blue identify LED.

[Turning the controller identify LED on and off](#)

#### Steps

1. Find the controller requiring maintenance in the data center.
  - Look for a lit blue identify LED on the front or rear of the controller.

The front identify LED is behind the controller front bezel and might be difficult to see if the bezel is installed.



- Check the tags attached to the front of each controller for a matching part number.
2. Remove the controller front bezel, if one is installed, to access the front panel controls and indicators.



3. Optional: Turn off the blue identify LED if you used it to locate the controller.
  - Press the identify LED switch on the controller front panel.
  - Use the controller BMC interface.

[Turning the controller identify LED on and off](#)

## Replacing the services appliance

You might need to replace the appliance if it is not functioning optimally or if it has failed.

### What you'll need

- You have a replacement appliance with the same part number as the appliance you are replacing.
- You have labels to identify each cable that is connected to the appliance.
- You have physically located the appliance that you are replacing in the data center. See [Locating the controller in a data center](#).
- The appliance has been placed maintenance mode. See [Placing an appliance into maintenance mode](#).

### About this task

The StorageGRID node will not be accessible while you replace the appliance. If the appliance is functioning sufficiently, you can perform a controlled shutdown at the start of this procedure.



If you are replacing the appliance before installing StorageGRID software, you might not be able to access the StorageGRID Appliance Installer immediately after completing this procedure. While you can access the StorageGRID Appliance Installer from other hosts on the same subnet as the appliance, you cannot access it from hosts on other subnets. This condition should resolve itself within 15 minutes (when any ARP cache entries for the original appliance time out), or you can clear the condition immediately by purging any old ARP cache entries manually from the local router or gateway.

### Steps

1. When the appliance has been placed maintenance mode, shut down the appliance.
  - a. Log in to the grid node:
    - i. Enter the following command: `ssh admin@grid_node_IP`
    - ii. Enter the password listed in the `Passwords.txt` file.
    - iii. Enter the following command to switch to root: `su -`
    - iv. Enter the password listed in the `Passwords.txt` file.

When you are logged in as root, the prompt changes from `$` to `#`.

- b. Shut down the appliance:  
**`shutdown -h now`**
2. Use one of two methods to verify that the power for the appliance is off:
  - The power indicator LED on the front of the appliance is off.
  - The Power Control page of the BMC interface indicates that the appliance is off.

3. If the StorageGRID networks attached to the appliance use DHCP servers, update DNS/network and IP address settings.

- a. Locate the MAC address label on the front of the appliance, and determine the MAC address for the Admin Network port.



The MAC address label lists the MAC address for the BMC management port.

To determine the MAC address for the Admin Network port, you must add **2** to the hexadecimal number on the label. For example, if the MAC address on the label ends in **09**, the MAC address for the Admin Port would end in **0B**. If the MAC address on the label ends in **(y)FF**, the MAC address for the Admin Port would end in **(y+1)01**. You can easily make this calculation by opening Calculator in Windows, setting it to Programmer mode, selecting Hex, typing the MAC address, then typing **+ 2 =**.

- b. Ask your network administrator to associate the DNS/network and IP address for the appliance you removed with the MAC address for the replacement appliance.



You must ensure that all IP addresses for the original appliance have been updated before you apply power to the replacement appliance. Otherwise, the appliance will obtain new DHCP IP addresses when it boots up and might not be able to reconnect to StorageGRID. This step applies to all StorageGRID networks that are attached to the appliance.



If the original appliance used static IP address, the new appliance will automatically adopt the IP addresses of the appliance you removed.

4. Remove and replace the appliance:

- a. Label the cables and then disconnect the cables and any network transceivers.



To prevent degraded performance, do not twist, fold, pinch, or step on the cables.

- b. Remove the failed appliance from the cabinet or rack.
- c. Transfer the two power supplies, eight cooling fans, and two SSDs from the failed appliance to the replacement appliance.

Follow the instructions provided for replacing these components.

- d. Install the replacement appliance into the cabinet or rack.
- e. Replace the cables and any optical transceivers.
- f. Power on the appliance and monitor the appliance LEDs and boot-up codes.

Use the BMC interface to monitor boot-up status.

5. Confirm that the appliance node appears in the Grid Manager and that no alerts appear.

#### Related information

[Installing the appliance into a cabinet or rack \(SG100 and SG1000\)](#)

[Viewing status indicators on the SG100 and SG1000 appliances](#)

[Viewing boot-up codes for the appliance](#)

# Replacing a power supply in the services appliance

The services appliance has two power supplies for redundancy. If one of the power supplies fails, you must replace it as soon as possible to ensure that the appliance has redundant power.

## What you'll need

- You have unpacked the replacement power supply unit.
- You have physically located the appliance where you are replacing the power supply in the data center.

### [Locating the controller in a data center](#)

- You can confirmed that the other power supply is installed and running.

## About this task

The figure shows the two power supply units for the SG100, which are accessible from the back of the appliance.



The power supplies for the SG1000 are identical.

## Steps

1. Unplug the power cord from the power supply.
2. Lift the cam handle.

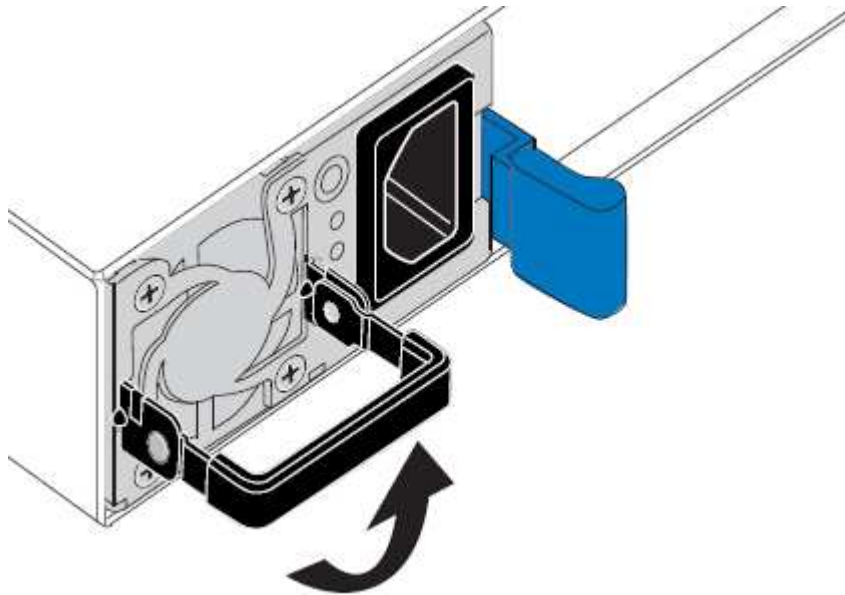

3. Press the blue latch and pull the power supply out.

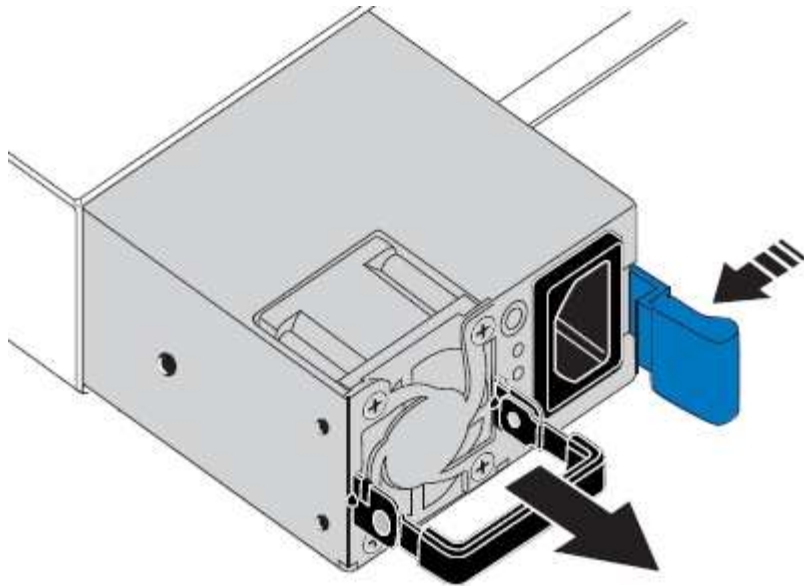

4. Slide the replacement power supply into the chassis.

Ensure that the blue latch is on the right side when you slide the unit in.

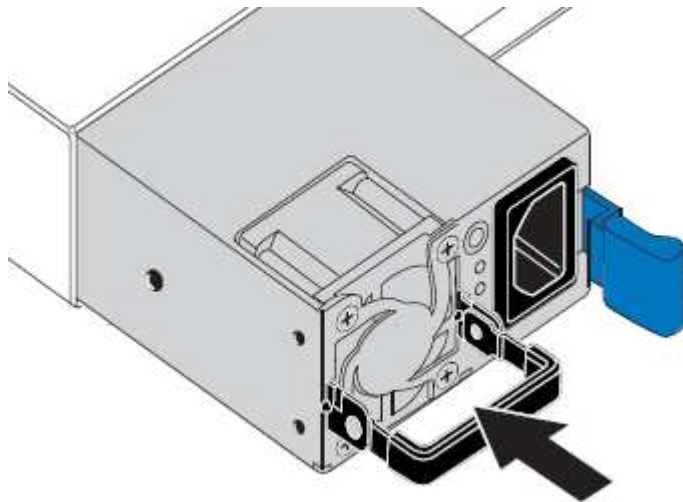

5. Push the cam handle down to secure the power supply.
6. Attach the power cord to the power supply, and ensure that the green LED comes on.

## Replacing a fan in the services appliance

The services appliance has eight cooling fans. If one of the fans fails, you must replace it as soon as possible to ensure that the appliance has proper cooling.

### What you'll need

- You have unpacked the replacement fan.
- You have physically located the appliance where you are replacing the fan in the data center.

### [Locating the controller in a data center](#)

- You have confirmed that the other fans are installed and running.

- The appliance has been placed maintenance mode.

### Placing an appliance into maintenance mode

#### About this task

The appliance node will not be accessible while you replace the fan.

The photograph shows a fan for the services appliance. The cooling fans are accessible after you take the top cover off of the appliance.



Each of the two power supply units also contain a fan. Those fans are not included in this procedure.



#### Steps

1. When the appliance has been placed maintenance mode, shut down the appliance.
  - a. Log in to the grid node:
    - i. Enter the following command: `ssh admin@grid_node_IP`
    - ii. Enter the password listed in the `Passwords.txt` file.
    - iii. Enter the following command to switch to root: `su -`
    - iv. Enter the password listed in the `Passwords.txt` file.

When you are logged in as root, the prompt changes from `$` to `#`.

- b. Shut down the services appliance:  
**`shutdown -h now`**
2. Use one of two methods to verify that the power for the services appliance is off:
    - The power indicator LED on the front of the appliance is off.
    - The Power Control page of the BMC interface indicates that the appliance is off.
  3. Lift the latch on the top cover and remove the cover from the appliance.
  4. Locate the fan that failed.

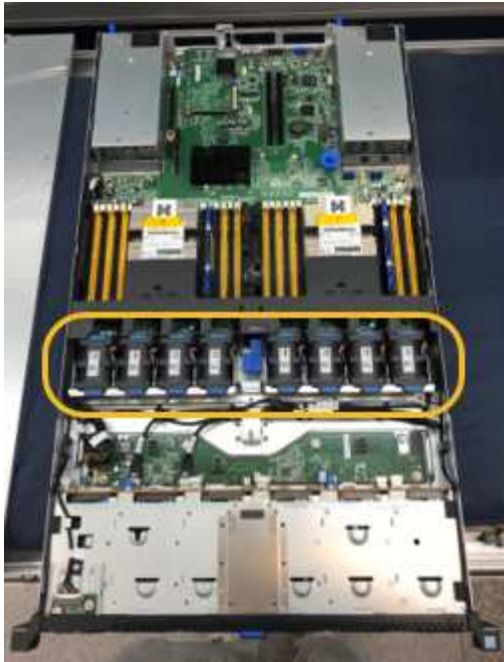

5. Lift the failed fan out of the chassis.

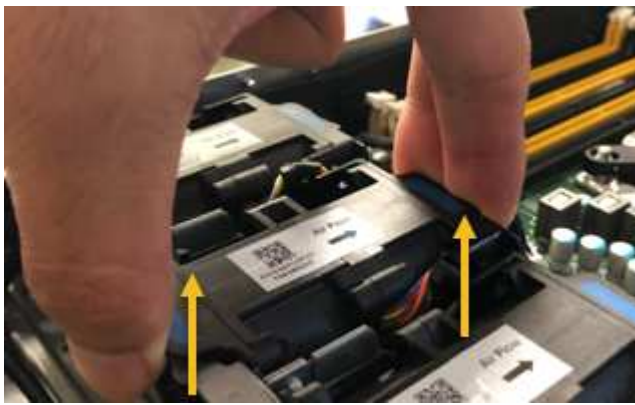

6. Slide the replacement fan into the open slot in the chassis.

Line up the edge of the fan with the guide pin. The pin is circled in the photograph.



7. Press the fan's connector firmly into the circuit board.



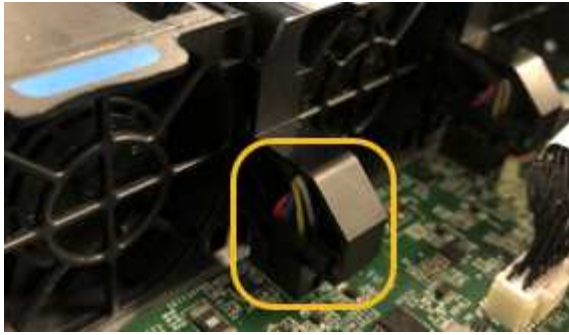

8. Put the top cover back on the appliance, and press the latch down to secure the cover in place.
9. Power on the appliance and monitor the controller LEDs and boot-up codes.

Use the BMC interface to monitor boot-up status.

10. Confirm that the appliance node appears in the Grid Manager and that no alerts appear.

## Replacing a drive in the services appliance

The SSDs in the services appliance contain the StorageGRID operating system. Additionally, when the appliance is configured as an Admin Node, the SSDs also contain audit logs, metrics, and database tables. The drives are mirrored using RAID1 for redundancy. If one of the drives fails, you must replace it as soon as possible to ensure redundancy.

### What you'll need

- You have physically located the appliance where you are replacing the drive in the data center.

[Locating the controller in a data center](#)

- You have verified which drive has failed by noting that its left LED is blinking amber.



If you remove the working drive, you will bring down the appliance node. See the information about viewing status indicators to verify the failure.

- You have obtained the replacement drive.
- You have obtained proper ESD protection.

### Steps

1. Verify that the drive's left LED is blinking amber.

You can also use the Grid Manager to monitor the status of the SSDs. Select **Nodes**. Then select **Appliance Node > Hardware**. If a drive has failed, the Storage RAID Mode field contains a message about which drive has failed.

2. Wrap the strap end of the ESD wristband around your wrist, and secure the clip end to a metal ground to prevent static discharge.
3. Unpack the replacement drive, and set it on a static-free, level surface near the appliance.

Save all packing materials.



4. Press the release button on the failed drive.

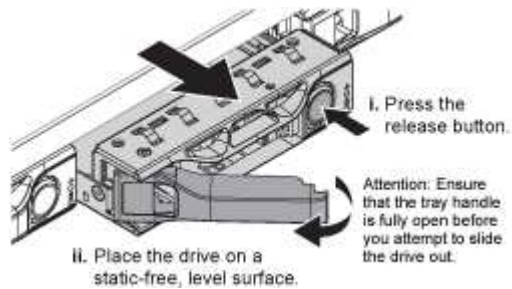

The handle on the drive springs open partially, and the drive releases from the slot.

5. Open the handle, slide the drive out, and place it on a static-free, level surface.
6. Press the release button on the replacement drive before you insert it into the drive slot.

The latch springs open.

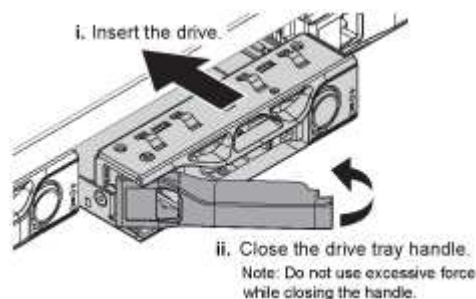

7. Insert the replacement drive in the slot, and then close the drive handle.



Do not use excessive force while closing the handle.

When the drive is fully inserted, you hear a click.

The drive is automatically rebuilt with mirrored data from the working drive. You can check the status of the rebuild by using the Grid Manager. Select **Nodes**. Then select **Appliance Node > Hardware**. The Storage RAID Mode field contains a “rebuilding” message until the drive is completely rebuilt.

8. Contact technical support about the drive replacement.

Technical support will provide instructions for returning the failed drive.

## Changing the link configuration of the services appliance

You can change the Ethernet link configuration of the services appliance. You can change the port bond mode, the network bond mode, and the link speed.

### What you'll need

- You must place the appliance in maintenance mode. Putting a StorageGRID appliance into maintenance mode might make the appliance unavailable for remote access.

[Placing an appliance into maintenance mode](#)

## About this task

Options for changing the Ethernet link configuration of the services appliance include:

- Changing **Port bond mode** from Fixed to Aggregate, or from Aggregate to Fixed
- Changing **Network bond mode** from Active-Backup to LACP, or from LACP to Active-Backup
- Enabling or disabling VLAN tagging, or changing the value of a VLAN tag
- Changing the link speed

## Steps

1. From the StorageGRID Appliance Installer, select **Configure Networking > Link Configuration**.

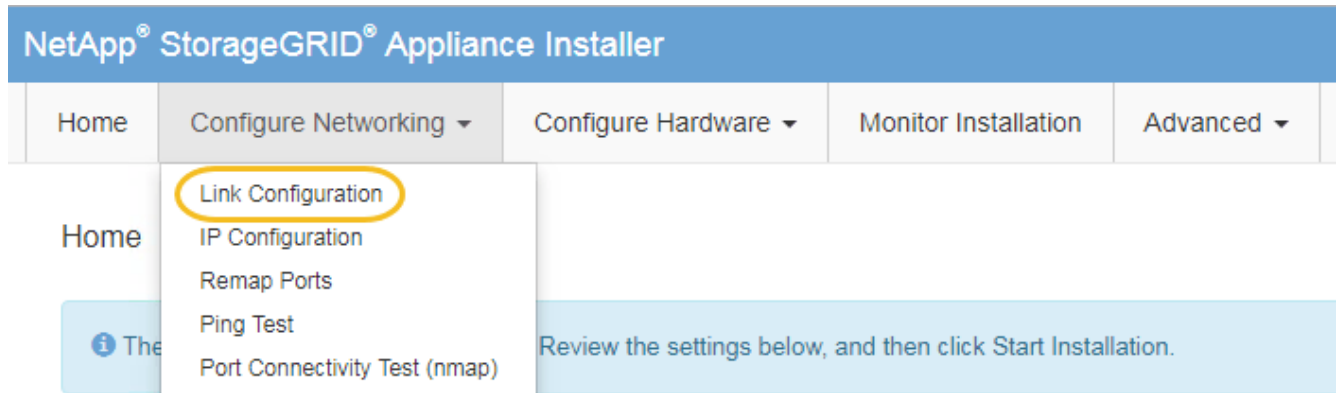

2. Make the desired changes to the link configuration.

For more information on the options, see “Configuring network links.”

3. When you are satisfied with your selections, click **Save**.



You might lose your connection if you made changes to the network or link you are connected through. If you are not reconnected within 1 minute, re-enter the URL for the StorageGRID Appliance Installer using one of the other IP addresses assigned to the appliance:

**`https://services_appliance_IP:8443`**

4. Make any necessary changes to the IP addresses for the appliance.

If you made changes to the VLAN settings, the subnet for the appliance might have changed. If you need to change the IP addresses for the appliance, follow the instructions for configuring IP addresses.

### [Configuring StorageGRID IP addresses](#)

5. Select **Configure Networking > Ping Test** from the menu.
6. Use the Ping Test tool to check connectivity to IP addresses on any networks that might have been affected by the link configuration changes you made when configuring the appliance.

In addition to any other tests you choose to perform, confirm that you can ping the Grid Network IP address of the primary Admin Node, and the Grid Network IP address of at least one other node. If necessary, return to the instructions for configuring network links, and correct any issues.

7. Once you are satisfied that your link configuration changes are working, reboot the node. From the

StorageGRID Appliance Installer, select **Advanced > Reboot Controller**, and then select one of these options:

- Select **Reboot into StorageGRID** to reboot the controller with the node rejoining the grid. Select this option if you are done working in maintenance mode and are ready to return the node to normal operation.
- Select **Reboot into Maintenance Mode** to reboot the controller with the node remaining in maintenance mode. Select this option if there are additional maintenance operations you need to perform on the node before rejoining the grid.

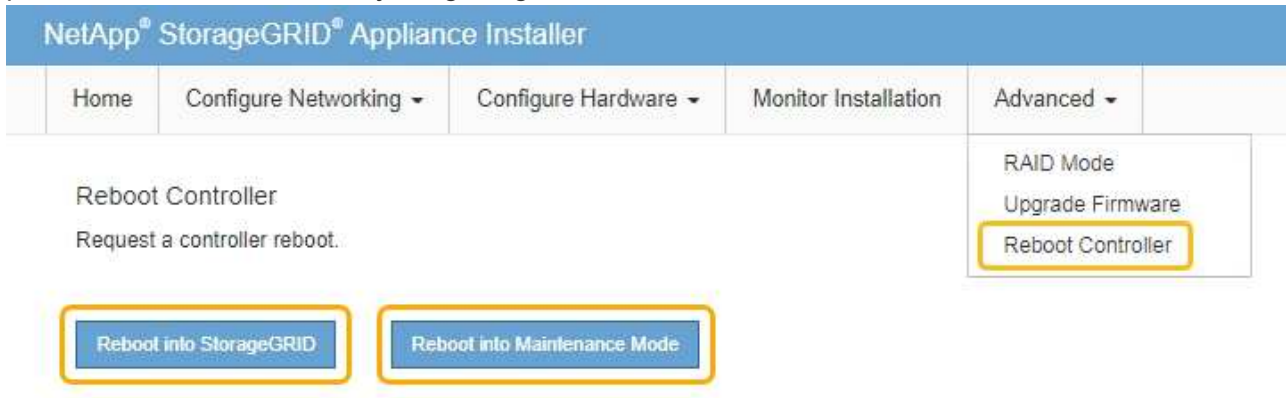

It can take up to 20 minutes for the appliance to reboot and rejoin the grid. To confirm that the reboot is complete and that the node has rejoined the grid, go back to the Grid Manager. The **Nodes** tab should display a normal status ✓ for the appliance node, indicating that no alerts are active and the node is connected to the grid.

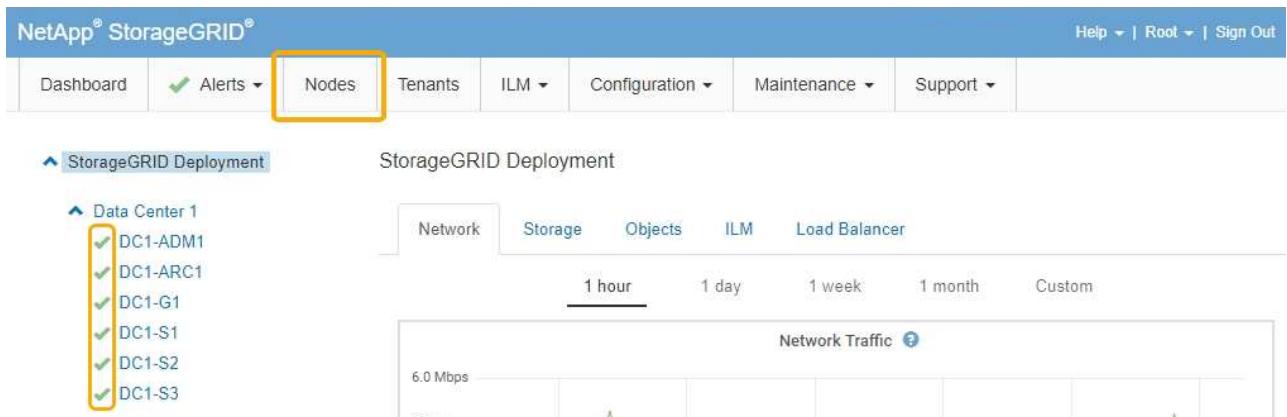

## Changing the MTU setting

You can change the MTU setting that you assigned when you configured IP addresses for the appliance node.

### What you'll need

The appliance has been placed in maintenance mode.

[Placing an appliance into maintenance mode](#)

### Steps

1. From the StorageGRID Appliance Installer, select **Configure Networking > IP Configuration**.
2. Make the desired changes to the MTU settings for the Grid Network, Admin Network, and Client Network.

### Grid Network

The Grid Network is used for all internal StorageGRID traffic. The Grid Network provides connectivity between all nodes in the grid, across all sites and subnets. All hosts on the Grid Network must be able to talk to all other hosts. The Grid Network can consist of multiple subnets. Networks containing critical grid services, such as NTP, can also be added as Grid subnets.

IP Assignment  Static  DHCP

IPv4 Address (CIDR)

Gateway

 All required Grid Network subnets must also be defined in the Grid Network Subnet List on the Primary Admin Node before starting installation.

Subnets (CIDR)  



MTU  



The MTU value of the network must match the value configured on the switch port the node is connected to. Otherwise, network performance issues or packet loss might occur.



For the best network performance, all nodes should be configured with similar MTU values on their Grid Network interfaces. The **Grid Network MTU mismatch** alert is triggered if there is a significant difference in MTU settings for the Grid Network on individual nodes. The MTU values do not have to be the same for all network types.

3. When you are satisfied with the settings, select **Save**.

4. Reboot the node. From the StorageGRID Appliance Installer, select **Advanced > Reboot Controller**, and then select one of these options:

- Select **Reboot into StorageGRID** to reboot the controller with the node rejoining the grid. Select this option if you are done working in maintenance mode and are ready to return the node to normal operation.
- Select **Reboot into Maintenance Mode** to reboot the controller with the node remaining in maintenance mode. Select this option if there are additional maintenance operations you need to perform on the node before rejoining the grid.

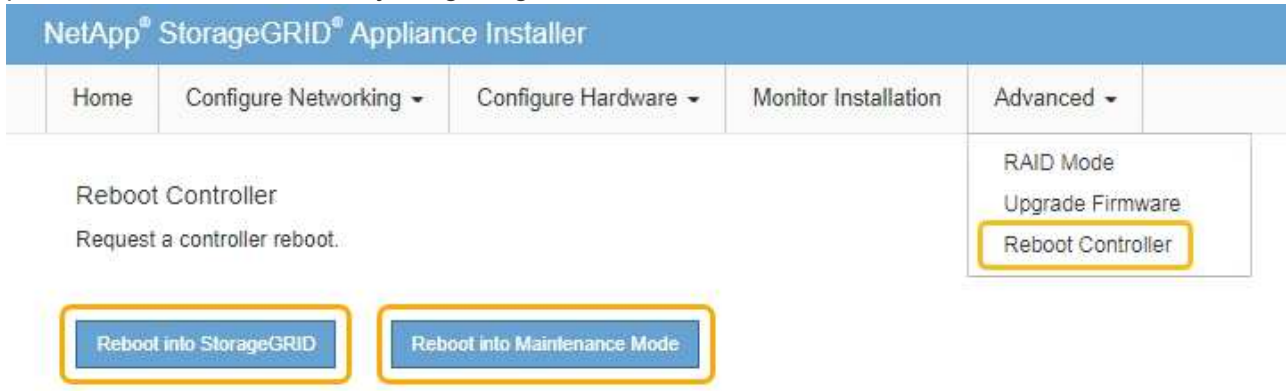

It can take up to 20 minutes for the appliance to reboot and rejoin the grid. To confirm that the reboot is complete and that the node has rejoined the grid, go back to the Grid Manager. The **Nodes** tab should display a normal status ✓ for the appliance node, indicating that no alerts are active and the node is connected to the grid.

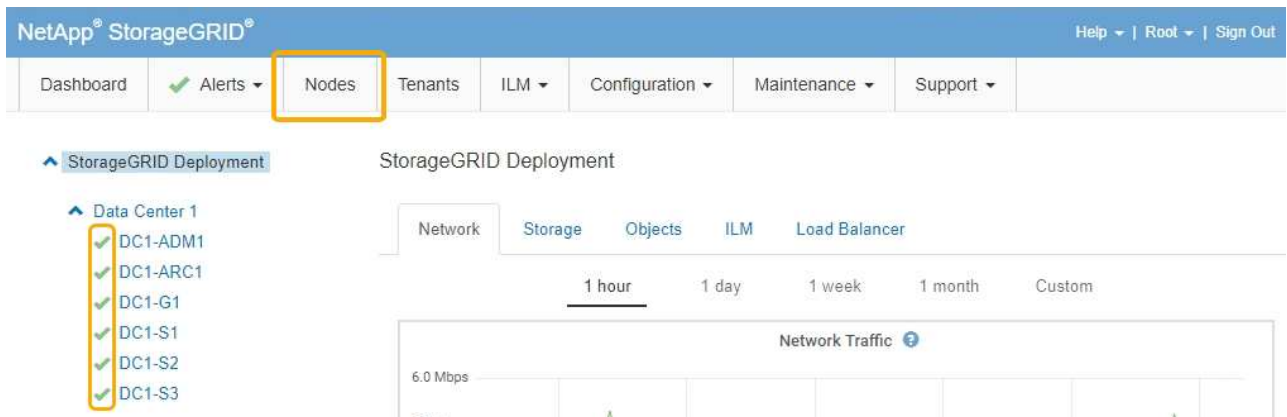

### Related information

[Administer StorageGRID](#)

## Checking the DNS server configuration

You can check and temporarily change the domain name system (DNS) servers that are currently in use by this appliance node.

### What you'll need

The appliance has been placed maintenance mode.

## Placing an appliance into maintenance mode

### About this task

You might need to change the DNS server settings if an encrypted appliance cannot connect to the key management server (KMS) or KMS cluster because the hostname for the KMS was specified as a domain name instead of an IP address. Any changes that you make to the DNS settings for the appliance are temporary and are lost when you exit maintenance mode. To make these changes permanent, specify the DNS servers in Grid Manager (**Maintenance > Network > DNS Servers**).

- Temporary changes to the DNS configuration are necessary only for node-encrypted appliances where the KMS server is defined using a fully qualified domain name, instead of an IP address, for the hostname.
- When a node-encrypted appliance connects to a KMS using a domain name, it must connect to one of the DNS servers defined for the grid. One of these DNS servers then translates the domain name into an IP address.
- If the node cannot reach a DNS server for the grid, or if you changed the grid-wide DNS settings when a node-encrypted appliance node was offline, the node is unable to connect to the KMS. Encrypted data on the appliance cannot be decrypted until the DNS issue is resolved.

To resolve a DNS issue preventing KMS connection, specify the IP address of one or more DNS servers in the StorageGRID Appliance Installer. These temporary DNS settings allow the appliance to connect to the KMS and decrypt data on the node.

For example, if the DNS server for the grid changes while an encrypted node was offline, the node will not be able to reach the KMS when it comes back online, since it is still using the previous DNS values. Entering the new DNS server IP address in the StorageGRID Appliance Installer allows a temporary KMS connection to decrypt the node data.



### Steps

1. From the StorageGRID Appliance Installer, select **Configure Networking > DNS Configuration**.
2. Verify that the DNS servers specified are correct.

#### DNS Servers

 Configuration changes made on this page will not be passed to the StorageGRID software after appliance installation.

#### Servers

Server 1	<input type="text" value="10.224.223.135"/>	
Server 2	<input type="text" value="10.224.223.136"/>	 
<input type="button" value="Cancel"/>		<input type="button" value="Save"/>

3. If required, change the DNS servers.



Changes made to the DNS settings are temporary and are lost when you exit maintenance mode.

4. When you are satisfied with the temporary DNS settings, select **Save**.

The node uses the DNS server settings specified on this page to reconnect to the KMS, allowing data on the node to be decrypted.

5. After node data is decrypted, reboot the node. From the StorageGRID Appliance Installer, select **Advanced > Reboot Controller**, and then select one of these options:
  - Select **Reboot into StorageGRID** to reboot the controller with the node rejoining the grid. Select this option if you are done working in maintenance mode and are ready to return the node to normal operation.
  - Select **Reboot into Maintenance Mode** to reboot the controller with the node remaining in maintenance mode. Select this option if there are additional maintenance operations you need to perform on the node before rejoining the grid.

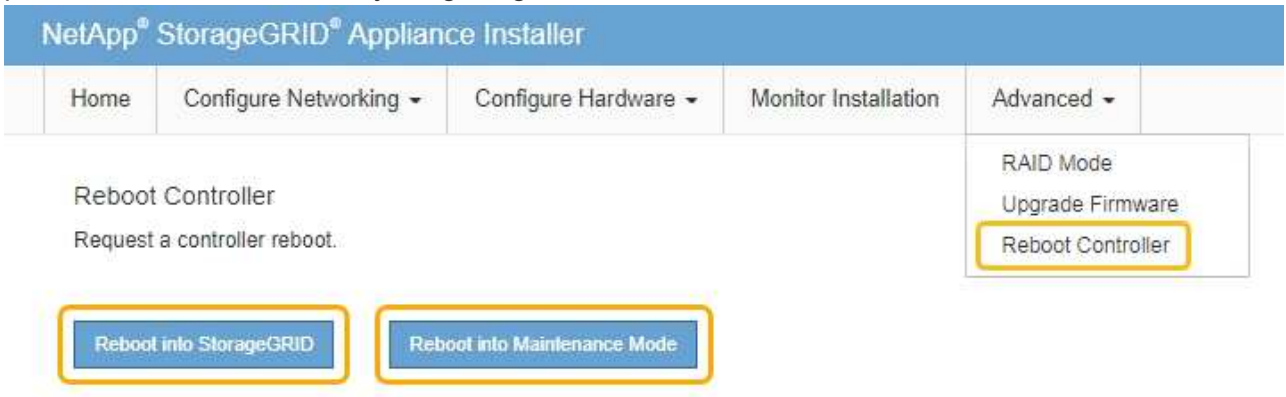

When the node reboots and rejoins the grid, it uses the system-wide DNS servers listed in the Grid Manager. After rejoining the grid, the appliance will no longer use the temporary DNS servers specified in the StorageGRID Appliance Installer while the appliance was in maintenance mode.

It can take up to 20 minutes for the appliance to reboot and rejoin the grid. To confirm that the reboot is complete and that the node has rejoined the grid, go back to the Grid Manager. The **Nodes** tab should display a normal status ✓ for the appliance node, indicating that no alerts are active and the node is connected to the grid.

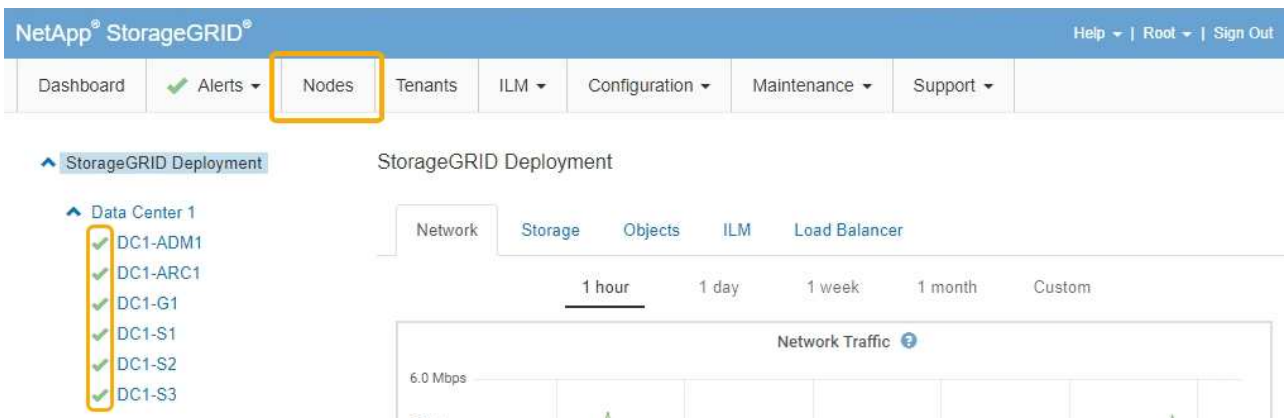



# Monitoring node encryption in maintenance mode

If you enabled node encryption for the appliance during installation, you can monitor the node-encryption status of each appliance node, including the node-encryption state and key management server (KMS) details.

## What you'll need

- Node encryption must have been enabled for the appliance during installation. You cannot enable node encryption after the appliance is installed.
- The appliance has been placed into maintenance mode.

[Placing an appliance into maintenance mode](#)

## Steps

1. From the StorageGRID Appliance Installer, select **Configure Hardware > Node Encryption**.

### Node Encryption

Node encryption allows you to use an external key management server (KMS) to encrypt all StorageGRID data on this appliance. If node encryption is enabled for the appliance and a KMS is configured for the site, you cannot access any data on the appliance unless the appliance can communicate with the KMS.

### Encryption Status

 You can only enable node encryption for an appliance during installation. You cannot enable or disable the node encryption setting after the appliance is installed.

Enable node encryption

Save

### Key Management Server Details

View the status and configuration details for the KMS that manages the encryption key for this appliance. You must use the Grid Manager to make configuration changes.

KMS display name	thales
External key UID	41b0306abcce451facfe01b1b4870ae1c1ec6bd5e3849d790223766baf35c57
Hostnames	10.96.99.164 10.96.99.165
Port	5696

Server certificate >

Client certificate >

### Clear KMS Key

 Do not clear the KMS key if you need to access or preserve any data on this appliance.

If you want to reinstall this appliance node (for example, in another grid), you must clear the KMS key. When the KMS key is cleared, all data on this appliance is deleted.

Clear KMS Key and Delete Data

The Node Encryption page includes these three sections:

- Encryption Status shows whether node encryption is enabled or disabled for the appliance.
- Key Management Server Details shows information about the KMS being used to encrypt the appliance. You can expand the server and client certificate sections to view certificate details and status.
  - To address issues with the certificates themselves, such as renewing expired certificates, see the information about KMS in the instructions for administering StorageGRID.
  - If there are unexpected problems connecting to KMS hosts, verify that the domain name system (DNS) servers are correct and that appliance networking is correctly configured.

#### Checking the DNS server configuration

- If you are unable to resolve your certificate issues, contact technical support.
- Clear KMS Key disables node encryption for the appliance, removes the association between the appliance and the key management server that was configured for the StorageGRID site, and deletes all data from the appliance. You must clear the KMS key before you can install the appliance into another StorageGRID system.

#### Clearing the key management server configuration



Clearing the KMS configuration deletes data from the appliance, rendering it permanently inaccessible. This data is not recoverable.

2. When you are done checking node-encryption status, reboot the node. From the StorageGRID Appliance Installer, select **Advanced > Reboot Controller**, and then select one of these options:

- Select **Reboot into StorageGRID** to reboot the controller with the node rejoining the grid. Select this option if you are done working in maintenance mode and are ready to return the node to normal operation.
- Select **Reboot into Maintenance Mode** to reboot the controller with the node remaining in maintenance mode. Select this option if there are additional maintenance operations you need to perform on the node before rejoining the grid.

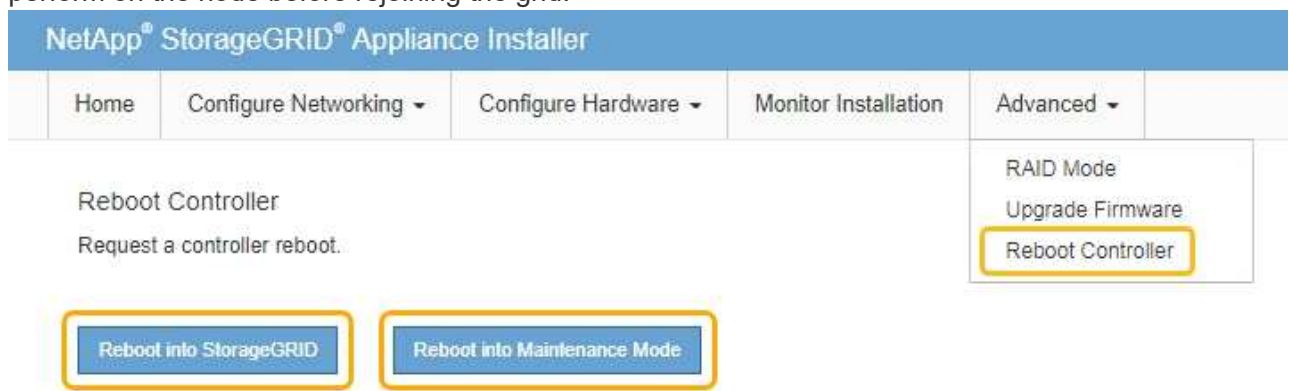

It can take up to 20 minutes for the appliance to reboot and rejoin the grid. To confirm that the reboot is complete and that the node has rejoined the grid, go back to the Grid Manager. The **Nodes** tab should display a normal status  for the appliance node, indicating that no alerts are active and the node is connected to the grid.

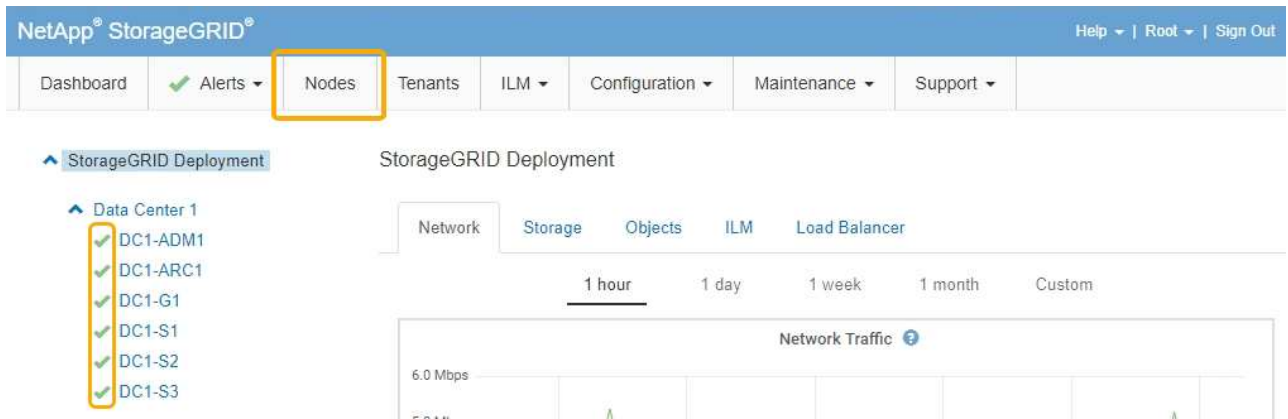

## Related information

[Administer StorageGRID](#)

## Clearing the key management server configuration

Clearing the key management server (KMS) configuration disables node encryption on your appliance. After clearing the KMS configuration, the data on your appliance is permanently deleted and is no longer accessible. This data is not recoverable.

### What you'll need

If you need to preserve data on the appliance, you must perform a node decommissioning procedure before you clear the KMS configuration.



When KMS is cleared, data on the appliance will be permanently deleted and no longer accessible. This data is not recoverable.

Decommission the node to move any data it contains to other nodes in StorageGRID. See the recovery and maintenance instructions for grid node decommissioning.

### About this task

Clearing the appliance KMS configuration disables node encryption, removing the association between the appliance node and the KMS configuration for the StorageGRID site. Data on the appliance is then deleted and the appliance is left in a pre-install state. This process cannot be reversed.

You must clear the KMS configuration:

- Before you can install the appliance into another StorageGRID system, that does not use a KMS or that uses a different KMS.



Do not clear the KMS configuration if you plan to reinstall an appliance node in a StorageGRID system that uses the same KMS key.

- Before you can recover and reinstall a node where the KMS configuration was lost and the KMS key is not recoverable.
- Before returning any appliance that was previously in use at your site.
- After decommissioning an appliance that had node encryption enabled.



Decommission the appliance before clearing KMS to move its data to other nodes in your StorageGRID system. Clearing KMS before decommissioning the appliance will result in data loss and might render the appliance inoperable.

## Steps

1. Open a browser, and enter one of the IP addresses for the appliance's compute controller.

**`https://Controller_IP:8443`**

*Controller\_IP* is the IP address of the compute controller (not the storage controller) on any of the three StorageGRID networks.

The StorageGRID Appliance Installer Home page appears.

2. Select **Configure Hardware > Node Encryption**.

### Node Encryption

Node encryption allows you to use an external key management server (KMS) to encrypt all StorageGRID data on this appliance. If node encryption is enabled for the appliance and a KMS is configured for the site, you cannot access any data on the appliance unless the appliance can communicate with the KMS.

### Encryption Status

You can only enable node encryption for an appliance during installation. You cannot enable or disable the node encryption setting after the appliance is installed.

Enable node encryption

Save

### Key Management Server Details

View the status and configuration details for the KMS that manages the encryption key for this appliance. You must use the Grid Manager to make configuration changes.

KMS display name	thales
External key UID	41b0306abcce451facfe01b1b4870ae1c1ec6bd5e3849d790223766baf35c57
Hostnames	10.96.99.164 10.96.99.165
Port	5696

Server certificate >

Client certificate >

### Clear KMS Key

Do not clear the KMS key if you need to access or preserve any data on this appliance.

If you want to reinstall this appliance node (for example, in another grid), you must clear the KMS key. When the KMS key is cleared, all data on this appliance is deleted.

Clear KMS Key and Delete Data



If the KMS configuration is cleared, data on the appliance will be permanently deleted. This data is not recoverable.

- At the bottom of the window, select **Clear KMS Key and Delete Data**.
- If you are sure that you want to clear the KMS configuration, type **clear** and select **Clear KMS Key and Delete Data**.

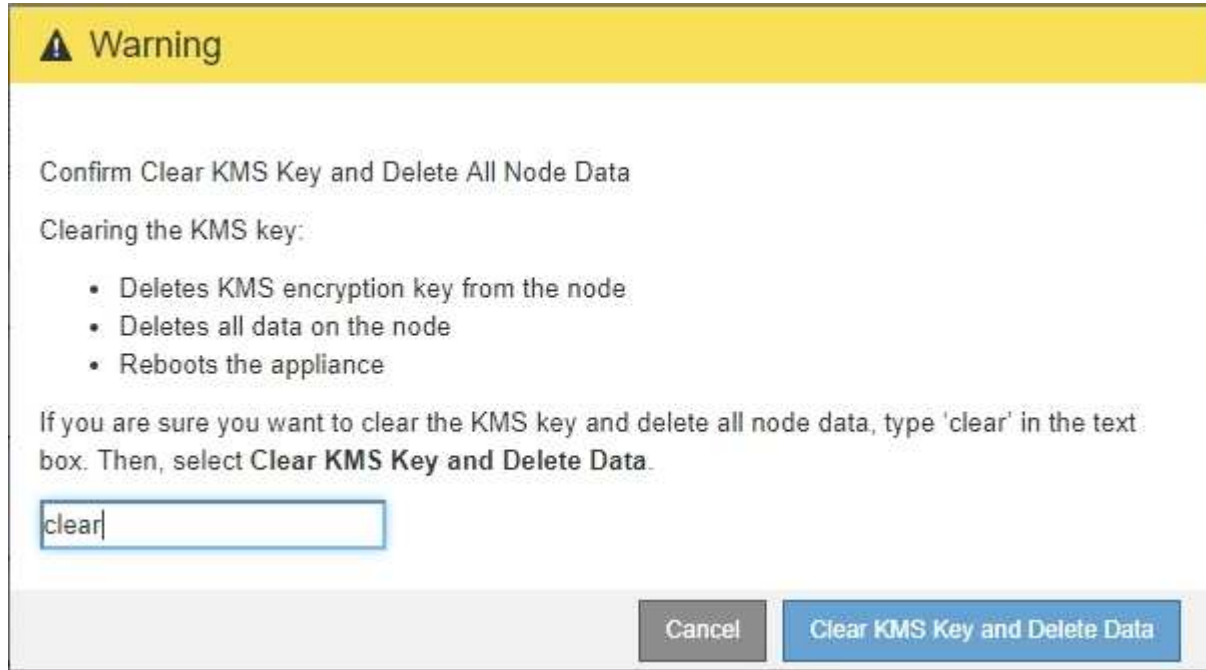

The KMS encryption key and all data are deleted from the node, and the appliance reboots. This can take up to 20 minutes.

- Open a browser, and enter one of the IP addresses for the appliance's compute controller.  
**https://Controller\_IP:8443**

*Controller\_IP* is the IP address of the compute controller (not the storage controller) on any of the three StorageGRID networks.

The StorageGRID Appliance Installer Home page appears.

- Select **Configure Hardware > Node Encryption**.
- Verify that node encryption is disabled and that the key and certificate information in **Key Management Server Details** and the **Clear KMS Key and Delete Data** control are removed from the window.

Node encryption cannot be reenabled on the appliance until it is reinstalled in a grid.

### After you finish

After the appliance reboots and you have verified that KMS has been cleared and that the appliance is in a pre-install state, you can physically remove the appliance from your StorageGRID system. See the recovery and maintenance instructions for information about preparing an appliance for reinstallation.

### Related information

[Administer StorageGRID](#)



## Copyright information

Copyright © 2024 NetApp, Inc. All Rights Reserved. Printed in the U.S. No part of this document covered by copyright may be reproduced in any form or by any means—graphic, electronic, or mechanical, including photocopying, recording, taping, or storage in an electronic retrieval system—without prior written permission of the copyright owner.

Software derived from copyrighted NetApp material is subject to the following license and disclaimer:

THIS SOFTWARE IS PROVIDED BY NETAPP “AS IS” AND WITHOUT ANY EXPRESS OR IMPLIED WARRANTIES, INCLUDING, BUT NOT LIMITED TO, THE IMPLIED WARRANTIES OF MERCHANTABILITY AND FITNESS FOR A PARTICULAR PURPOSE, WHICH ARE HEREBY DISCLAIMED. IN NO EVENT SHALL NETAPP BE LIABLE FOR ANY DIRECT, INDIRECT, INCIDENTAL, SPECIAL, EXEMPLARY, OR CONSEQUENTIAL DAMAGES (INCLUDING, BUT NOT LIMITED TO, PROCUREMENT OF SUBSTITUTE GOODS OR SERVICES; LOSS OF USE, DATA, OR PROFITS; OR BUSINESS INTERRUPTION) HOWEVER CAUSED AND ON ANY THEORY OF LIABILITY, WHETHER IN CONTRACT, STRICT LIABILITY, OR TORT (INCLUDING NEGLIGENCE OR OTHERWISE) ARISING IN ANY WAY OUT OF THE USE OF THIS SOFTWARE, EVEN IF ADVISED OF THE POSSIBILITY OF SUCH DAMAGE.

NetApp reserves the right to change any products described herein at any time, and without notice. NetApp assumes no responsibility or liability arising from the use of products described herein, except as expressly agreed to in writing by NetApp. The use or purchase of this product does not convey a license under any patent rights, trademark rights, or any other intellectual property rights of NetApp.

The product described in this manual may be protected by one or more U.S. patents, foreign patents, or pending applications.

LIMITED RIGHTS LEGEND: Use, duplication, or disclosure by the government is subject to restrictions as set forth in subparagraph (b)(3) of the Rights in Technical Data -Noncommercial Items at DFARS 252.227-7013 (FEB 2014) and FAR 52.227-19 (DEC 2007).

Data contained herein pertains to a commercial product and/or commercial service (as defined in FAR 2.101) and is proprietary to NetApp, Inc. All NetApp technical data and computer software provided under this Agreement is commercial in nature and developed solely at private expense. The U.S. Government has a non-exclusive, non-transferrable, nonsublicensable, worldwide, limited irrevocable license to use the Data only in connection with and in support of the U.S. Government contract under which the Data was delivered. Except as provided herein, the Data may not be used, disclosed, reproduced, modified, performed, or displayed without the prior written approval of NetApp, Inc. United States Government license rights for the Department of Defense are limited to those rights identified in DFARS clause 252.227-7015(b) (FEB 2014).

## Trademark information

NETAPP, the NETAPP logo, and the marks listed at <http://www.netapp.com/TM> are trademarks of NetApp, Inc. Other company and product names may be trademarks of their respective owners.