



Managing high availability groups

StorageGRID 11.5

NetApp
August 30, 2024

Table of Contents

- Managing high availability groups 1
 - What an HA group is 1
 - How HA groups are used 2
 - Configuration options for HA groups 3
 - Creating a high availability group 5
 - Editing a high availability group 9
 - Removing a high availability group 12

Managing high availability groups

High availability (HA) groups can be used to provide highly available data connections for S3 and Swift clients. HA groups can also be used to provide highly available connections to the Grid Manager and the Tenant Manager.

- [What an HA group is](#)
- [How HA groups are used](#)
- [Configuration options for HA groups](#)
- [Creating a high availability group](#)
- [Editing a high availability group](#)
- [Removing a high availability group](#)

What an HA group is

High availability groups use virtual IP addresses (VIPs) to provide active-backup access to Gateway Node or Admin Node services.

An HA group consists of one or more network interfaces on Admin Nodes and Gateway Nodes. When creating an HA group, you select network interfaces belonging to the Grid Network (eth0) or the Client Network (eth2). All interfaces in an HA group must be within the same network subnet.

An HA group maintains one or more virtual IP addresses that are added to the active interface in the group. If the active interface becomes unavailable, the virtual IP addresses are moved to another interface. This failover process generally takes only a few seconds and is fast enough that client applications should experience little impact and can rely on normal retry behaviors to continue operation.

The active interface in an HA group is designated as the Master. All other interfaces are designated as Backup. To view these designations, select **Nodes > node > Overview**.

DC1-ADM1 (Admin Node)

Overview Hardware Network Storage Load Balancer Events Tasks

Node Information ⓘ

Name	DC1-ADM1
Type	Admin Node
ID	711b7b9b-8d24-4d9f-877a-be3fa3ac27e8
Connection State	✔ Connected
Software Version	11.4.0 (build 20200515.2346.8edcbbf)
HA Groups	Fabric Pools, Master
IP Addresses	192.168.2.208, 10.224.2.208, 47.47.2.208, 47.47.4.219 Show more ▼

When creating an HA group, you specify one interface to be the preferred Master. The preferred Master is the active interface unless a failure occurs that causes the VIP addresses to be reassigned to a Backup interface. When the failure is resolved, the VIP addresses are automatically moved back to the preferred Master.

Failover can be triggered for any of these reasons:

- The node on which the interface is configured goes down.
- The node on which the interface is configured loses connectivity to all other nodes for at least 2 minutes
- The active interface goes down.
- The Load Balancer service stops.
- The High Availability service stops.



Failover might not be triggered by network failures external to the node that hosts the active interface. Similarly, failover is not triggered by the failure of the CLB service (deprecated) or services for the Grid Manager or the Tenant Manager.

If the HA group includes interfaces from more than two nodes, the active interface might move to any other node's interface during failover.

How HA groups are used

You might want to use high availability (HA) groups for several reasons.

- An HA group can provide highly available administrative connections to the Grid Manager or the Tenant Manager.
- An HA group can provide highly available data connections for S3 and Swift clients.
- An HA group that contains only one interface allows you to provide many VIP addresses and to explicitly set IPv6 addresses.

An HA group can provide high availability only if all nodes included in the group provide the same services. When you create an HA group, add interfaces from the types of nodes that provide the services you require.

- **Admin Nodes:** Include the Load Balancer service and enable access to the Grid Manager or the Tenant Manager.
- **Gateway Nodes:** Include the Load Balancer service and the CLB service (deprecated).

Purpose of HA group	Add nodes of this type to the HA group
Access to Grid Manager	<ul style="list-style-type: none"> • Primary Admin Node (preferred Master) • Non-primary Admin Nodes <p>Note: The primary Admin Node must be the preferred Master. Some maintenance procedures can only be performed from the primary Admin Node.</p>
Access to Tenant Manager only	<ul style="list-style-type: none"> • Primary or non-primary Admin Nodes

Purpose of HA group	Add nodes of this type to the HA group
S3 or Swift client access — Load Balancer service	<ul style="list-style-type: none"> • Admin Nodes • Gateway Nodes
S3 or Swift client access — CLB service Note: The CLB service is deprecated.	<ul style="list-style-type: none"> • Gateway Nodes

Limitations of using HA groups with Grid Manager or Tenant Manager

The failure of services for the Grid Manager or the Tenant Manager does not trigger failover within the HA group.

If you are signed in to the Grid Manager or the Tenant Manager when failover occurs, you are signed out and must sign in again to resume your task.

Some maintenance procedures cannot be performed when the primary Admin Node is unavailable. During failover, you can use the Grid Manager to monitor your StorageGRID system.

Limitations of using HA groups with the CLB service

The failure of the CLB service does not trigger failover within the HA group.



The CLB service is deprecated.

Configuration options for HA groups

The following diagrams provide examples of different ways you can configure HA groups. Each option has advantages and disadvantages.

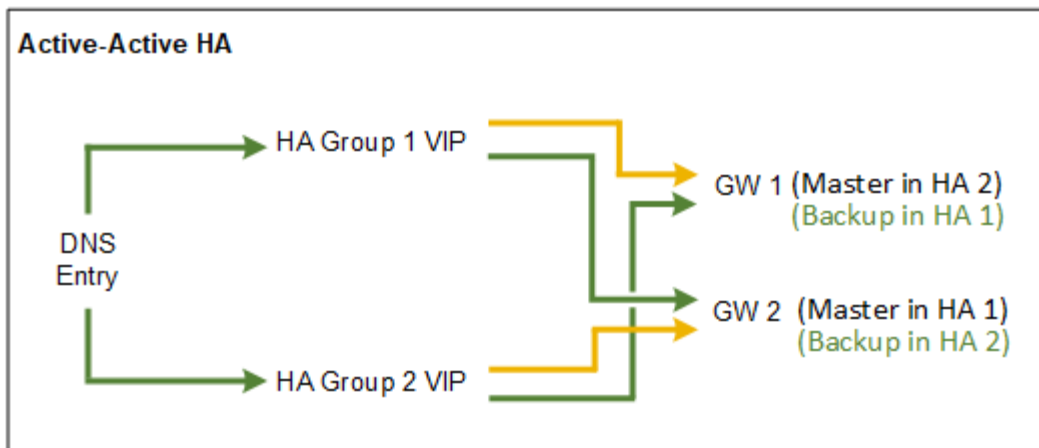
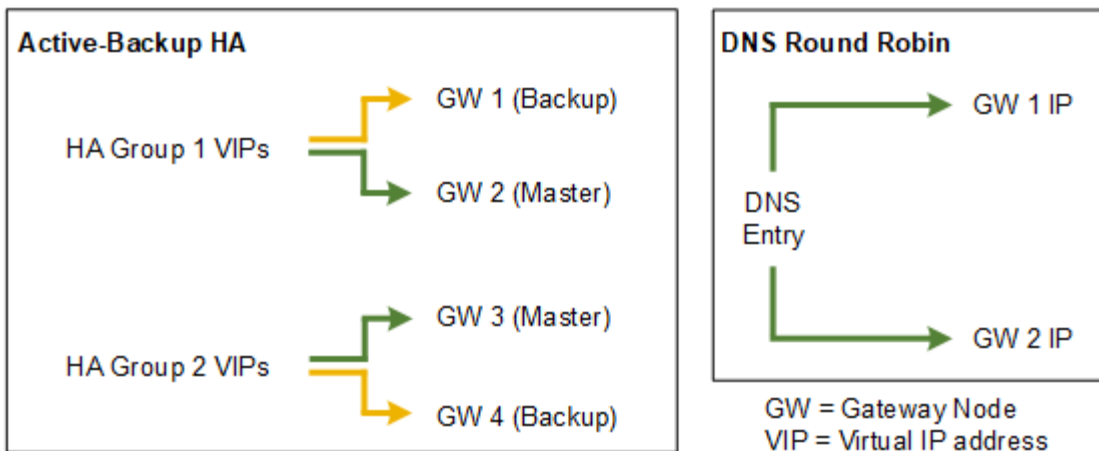

When creating multiple overlapping HA groups as shown in the Active-Active HA example, the total throughput scales with the number of nodes and HA groups. With three or more nodes and three or more HA groups, you also gain the ability to continue operations using any of the VIPs even during maintenance procedures that require you to take a node offline.

The table summarizes the benefits of each HA configuration shown in the diagram.

Configuration	Advantages	Disadvantages
Active-Backup HA	<ul style="list-style-type: none"> • Managed by StorageGRID with no external dependencies. • Fast failover. 	<ul style="list-style-type: none"> • Only one node in an HA group is active. At least one node per HA group will be idle.
DNS Round Robin	<ul style="list-style-type: none"> • Increased aggregate throughput. • No idle hosts. 	<ul style="list-style-type: none"> • Slow failover, which could depend on client behavior. • Requires configuration of hardware outside of StorageGRID. • Needs a customer-implemented health check.

Configuration	Advantages	Disadvantages
Active-Active	<ul style="list-style-type: none"> Traffic is distributed across multiple HA groups. High aggregate throughput that scales with the number of HA groups. Fast failover. 	<ul style="list-style-type: none"> More complex to configure. Requires configuration of hardware outside of StorageGRID. Needs a customer-implemented health check.

Creating a high availability group

You can create one or more high availability (HA) groups to provide highly available access to the services on Admin Nodes or Gateway Nodes.

What you'll need

- You must be signed in to the Grid Manager using a supported browser.
- You must have the Root Access permission.

About this task

An interface must meet the following conditions to be included in an HA group:

- The interface must be for a Gateway Node or an Admin Node.
- The interface must belong to the Grid Network (eth0) or the Client Network (eth2).
- The interface must be configured with fixed or static IP addressing, not with DHCP.

Steps

- Select **Configuration > Network Settings > High Availability Groups**.

The High Availability Groups page appears.

High Availability Groups

High availability (HA) groups allow multiple nodes to participate in an active-backup group. HA groups maintain virtual IP addresses on the active node and switch to a backup node automatically if a node fails.



- Click **Create**.

The Create High Availability Group dialog box appears.

- Type a name and, if desired, a description for the HA group.
- Click **Select Interfaces**.

The Add Interfaces to High Availability Group dialog box appears. The table lists eligible nodes, interfaces, and IPv4 subnets.

Add Interfaces to High Availability Group

Select interfaces to include in the HA group. All interfaces must be in the same network subnet.

Add to HA group	Node Name	Interface	IPv4 Subnet	Unavailable Reason
	g140-g1	eth0	172.16.0.0/21	This IP address is not in the same subnet as the selected interfaces
	g140-g1	eth2	47.47.0.0/21	This IP address is not in the same subnet as the selected interfaces
	g140-g2	eth0	172.16.0.0/21	This IP address is not in the same subnet as the selected interfaces
	g140-g2	eth2	47.47.0.0/21	This IP address is not in the same subnet as the selected interfaces
	g140-g3	eth0	172.16.0.0/21	This IP address is not in the same subnet as the selected interfaces
<input checked="" type="checkbox"/>	g140-g3	eth2	192.168.0.0/21	
	g140-g4	eth0	172.16.0.0/21	This IP address is not in the same subnet as the selected interfaces
<input checked="" type="checkbox"/>	g140-g4	eth2	192.168.0.0/21	

There are 2 interfaces selected.

Cancel

Apply

An interface does not appear in the list if its IP address is assigned by DHCP.

5. In the **Add to HA group** column, select the check box for the interface you want to add to the HA group.

Note the following guidelines for selecting interfaces:

- You must select at least one interface.
- If you select more than one interface, all of the interfaces must be on either the Grid Network (eth0) or on the Client Network (eth2).
- All interfaces must be in the same subnet or in subnets with a common prefix.

IP addresses will be restricted to the smallest subnet (the one with the largest prefix).

- If you select interfaces on different types of nodes, and a failover occurs, only the services common to the selected nodes will be available on the virtual IPs.
 - Select two or more Admin Nodes for HA protection of the Grid Manager or the Tenant Manager.
 - Select two or more Admin Nodes, Gateway Nodes, or both for HA protection of the Load Balancer service.
 - Select two or more Gateway Nodes for HA protection of the CLB service.



The CLB service is deprecated.

Add Interfaces to High Availability Group

Select interfaces to include in the HA group. All interfaces must be in the same network subnet.

Add to HA group	Node Name	Interface	IPv4 Subnet	Unavailable Reason
<input checked="" type="checkbox"/>	DC1-ADM1	eth0	10.96.100.0/23	
<input checked="" type="checkbox"/>	DC1-G1	eth0	10.96.100.0/23	
<input checked="" type="checkbox"/>	DC2-ADM1	eth0	10.96.100.0/23	

There are 3 interfaces selected.

Attention: You have selected nodes of different types that run different services. If a failover occurs, only the services common to all node types will be available on the virtual IPs.

Cancel

Apply

6. Click **Apply**.

The interfaces you selected are listed in the Interfaces section of the Create High Availability Group page. By default, the first interface in the list is selected as the Preferred Master.

Create High Availability Group

High Availability Group

Name

Description

Interfaces

Select interfaces to include in the HA group. All interfaces must be in the same network subnet.

Select Interfaces

Node Name	Interface	IPv4 Subnet	Preferred Master
g140-g1	eth2	47.47.0.0/21	<input checked="" type="radio"/>
g140-g2	eth2	47.47.0.0/21	<input type="radio"/>

Displaying 2 interfaces.

Virtual IP Addresses

Virtual IP Subnet: 47.47.0.0/21. All virtual IP addresses must be within this subnet. There must be at least 1 and no more than 10 virtual IP addresses.

Virtual IP Address 1



Cancel

Save

- If you want a different interface to be the preferred Master, select that interface in the **Preferred Master** column.

The preferred Master is the active interface unless a failure occurs that causes the VIP addresses to be reassigned to a Backup interface.



If the HA group provides access to the Grid Manager, you must select an interface on the primary Admin Node to be the preferred Master. Some maintenance procedures can only be performed from the primary Admin Node.

- In the Virtual IP Addresses section of the page, enter one to 10 virtual IP addresses for the HA group. Click the plus sign (+) to add multiple IP addresses.

You must provide at least one IPv4 address. Optionally, you can specify additional IPv4 and IPv6 addresses.

IPv4 addresses must be within the IPv4 subnet shared by all of the member interfaces.

9. Click **Save**.

The HA Group is created, and you can now use the configured virtual IP addresses.

Related information

[Install Red Hat Enterprise Linux or CentOS](#)

[Install VMware](#)

[Install Ubuntu or Debian](#)

[Managing load balancing](#)

Editing a high availability group

You can edit a high availability (HA) group to change its name and description, add or remove interfaces, or add or update a virtual IP address.

What you'll need

- You must be signed in to the Grid Manager using a supported browser.
- You must have the Root Access permission.

About this task

Some of the reasons for editing an HA group include the following:

- Adding an interface to an existing group. The interface IP address must be within the same subnet as other interfaces already assigned to the group.
- Removing an interface from an HA group. For example, you cannot start a site or node decommission procedure if a node's interface for the Grid Network or the Client Network is used in an HA group.

Steps

1. Select **Configuration > Network Settings > High Availability Groups**.

The High Availability Groups page appears.

High Availability Groups

High availability (HA) groups allow multiple nodes to participate in an active-backup group. HA groups maintain virtual IP addresses on the active node and switch to a backup node automatically if a node fails.

<input type="button" value="+ Create"/> <input type="button" value="✎ Edit"/> <input type="button" value="✕ Remove"/>				
	Name	Description	Virtual IP Addresses	Interfaces
<input type="radio"/>	HA Group 1		47.47.4.219	g140-adm1:eth2 (preferred Master) g140-g1:eth2
<input type="radio"/>	HA Group 2		47.47.4.218 47.47.4.217	g140-g1:eth2 (preferred Master) g140-g2:eth2

Displaying 2 HA groups.

2. Select the HA group you want to edit, and click **Edit**.

The Edit High Availability Group dialog box appears.

3. Optionally, update the group's name or description.
4. Optionally, click **Select Interfaces** to change the interfaces for the HA Group.

The Add Interfaces to High Availability Group dialog box appears.

Add Interfaces to High Availability Group

Select interfaces to include in the HA group. All interfaces must be in the same network subnet.

Add to HA group	Node Name	Interface	IPv4 Subnet	Unavailable Reason
	g140-g1	eth0	172.16.0.0/21	This IP address is not in the same subnet as the selected interfaces
	g140-g1	eth2	47.47.0.0/21	This IP address is not in the same subnet as the selected interfaces
	g140-g2	eth0	172.16.0.0/21	This IP address is not in the same subnet as the selected interfaces
	g140-g2	eth2	47.47.0.0/21	This IP address is not in the same subnet as the selected interfaces
	g140-g3	eth0	172.16.0.0/21	This IP address is not in the same subnet as the selected interfaces
<input checked="" type="checkbox"/>	g140-g3	eth2	192.168.0.0/21	
	g140-g4	eth0	172.16.0.0/21	This IP address is not in the same subnet as the selected interfaces
<input checked="" type="checkbox"/>	g140-g4	eth2	192.168.0.0/21	

There are 2 interfaces selected.

An interface does not appear in the list if its IP address is assigned by DHCP.

5. Select or unselect the check boxes to add or remove interfaces.

Note the following guidelines for selecting interfaces:

- You must select at least one interface.
- If you select more than one interface, all of the interfaces must be on either the Grid Network (eth0) or on the Client Network (eth2).
- All interfaces must be in the same subnet or in subnets with a common prefix.

IP addresses will be restricted to the smallest subnet (the one with the largest prefix).

- If you select interfaces on different types of nodes, and a failover occurs, only the services common to the selected nodes will be available on the virtual IPs.
 - Select two or more Admin Nodes for HA protection of the Grid Manager or the Tenant Manager.
 - Select two or more Admin Nodes, Gateway Nodes, or both for HA protection of the Load Balancer service.
 - Select two or more Gateway Nodes for HA protection of the CLB service.



The CLB service is deprecated.

6. Click **Apply**.

The interfaces you selected are listed in the Interfaces section of the page. By default, the first interface in the list is selected as the Preferred Master.

Edit High Availability Group 'HA Group - Admin Nodes'

High Availability Group

Name

Description

Interfaces

Select interfaces to include in the HA group. All interfaces must be in the same network subnet.

Node Name	Interface	IPv4 Subnet	Preferred Master
DC1-ADM1	eth0	10.96.100.0/23	<input checked="" type="radio"/>
DC2-ADM1	eth0	10.96.100.0/23	<input type="radio"/>

Displaying 2 interfaces.

Virtual IP Addresses

Virtual IP Subnet: 10.96.100.0/23. All virtual IP addresses must be within this subnet. There must be at least 1 and no more than 10 virtual IP addresses.

Virtual IP Address 1



- If you want a different interface to be the preferred Master, select that interface in the **Preferred Master** column.

The preferred Master is the active interface unless a failure occurs that causes the VIP addresses to be reassigned to a Backup interface.



If the HA group provides access to the Grid Manager, you must select an interface on the primary Admin Node to be the preferred Master. Some maintenance procedures can only be performed from the primary Admin Node.

- Optionally, update the virtual IP addresses for the HA group.

You must provide at least one IPv4 address. Optionally, you can specify additional IPv4 and IPv6 addresses.

IPv4 addresses must be within the IPv4 subnet shared by all of the member interfaces.

9. Click **Save**.

The HA Group is updated.

Removing a high availability group

You can remove a high availability (HA) group that you are no longer using.

What you'll need

- You must be signed in to the Grid Manager using a supported browser.
- You must have the Root Access permission.

About this task

If you remove an HA group, any S3 or Swift clients that are configured to use one of the group's virtual IP addresses will no longer be able to connect to StorageGRID. To prevent client disruptions, you should update all affected S3 or Swift client applications before you remove an HA group. Update each client to connect using another IP address, for example, the virtual IP address of a different HA group or the IP address that was configured for an interface during installation or using DHCP.

Steps

1. Select **Configuration > Network Settings > High Availability Groups**.

The High Availability Groups page appears.

High Availability Groups

High availability (HA) groups allow multiple nodes to participate in an active-backup group. HA groups maintain virtual IP addresses on the active node and switch to a backup node automatically if a node fails.

<input type="button" value="+ Create"/> <input type="button" value="Edit"/> <input type="button" value="Remove"/>				
	Name	Description	Virtual IP Addresses	Interfaces
<input type="radio"/>	HA Group 1		47.47.4.219	g140-adm1:eth2 (preferred Master) g140-g1:eth2
<input type="radio"/>	HA Group 2		47.47.4.218 47.47.4.217	g140-g1:eth2 (preferred Master) g140-g2:eth2

Displaying 2 HA groups.

2. Select the HA group you want to remove, and click **Remove**.

The Delete High Availability Group warning appears.

 Warning

Delete High Availability Group

Are you sure you want to delete High Availability Group 'HA group 1'?

Cancel

OK

3. Click **OK**.

The HA group is removed.

Copyright information

Copyright © 2024 NetApp, Inc. All Rights Reserved. Printed in the U.S. No part of this document covered by copyright may be reproduced in any form or by any means—graphic, electronic, or mechanical, including photocopying, recording, taping, or storage in an electronic retrieval system—without prior written permission of the copyright owner.

Software derived from copyrighted NetApp material is subject to the following license and disclaimer:

THIS SOFTWARE IS PROVIDED BY NETAPP “AS IS” AND WITHOUT ANY EXPRESS OR IMPLIED WARRANTIES, INCLUDING, BUT NOT LIMITED TO, THE IMPLIED WARRANTIES OF MERCHANTABILITY AND FITNESS FOR A PARTICULAR PURPOSE, WHICH ARE HEREBY DISCLAIMED. IN NO EVENT SHALL NETAPP BE LIABLE FOR ANY DIRECT, INDIRECT, INCIDENTAL, SPECIAL, EXEMPLARY, OR CONSEQUENTIAL DAMAGES (INCLUDING, BUT NOT LIMITED TO, PROCUREMENT OF SUBSTITUTE GOODS OR SERVICES; LOSS OF USE, DATA, OR PROFITS; OR BUSINESS INTERRUPTION) HOWEVER CAUSED AND ON ANY THEORY OF LIABILITY, WHETHER IN CONTRACT, STRICT LIABILITY, OR TORT (INCLUDING NEGLIGENCE OR OTHERWISE) ARISING IN ANY WAY OUT OF THE USE OF THIS SOFTWARE, EVEN IF ADVISED OF THE POSSIBILITY OF SUCH DAMAGE.

NetApp reserves the right to change any products described herein at any time, and without notice. NetApp assumes no responsibility or liability arising from the use of products described herein, except as expressly agreed to in writing by NetApp. The use or purchase of this product does not convey a license under any patent rights, trademark rights, or any other intellectual property rights of NetApp.

The product described in this manual may be protected by one or more U.S. patents, foreign patents, or pending applications.

LIMITED RIGHTS LEGEND: Use, duplication, or disclosure by the government is subject to restrictions as set forth in subparagraph (b)(3) of the Rights in Technical Data -Noncommercial Items at DFARS 252.227-7013 (FEB 2014) and FAR 52.227-19 (DEC 2007).

Data contained herein pertains to a commercial product and/or commercial service (as defined in FAR 2.101) and is proprietary to NetApp, Inc. All NetApp technical data and computer software provided under this Agreement is commercial in nature and developed solely at private expense. The U.S. Government has a non-exclusive, non-transferrable, nonsublicensable, worldwide, limited irrevocable license to use the Data only in connection with and in support of the U.S. Government contract under which the Data was delivered. Except as provided herein, the Data may not be used, disclosed, reproduced, modified, performed, or displayed without the prior written approval of NetApp, Inc. United States Government license rights for the Department of Defense are limited to those rights identified in DFARS clause 252.227-7015(b) (FEB 2014).

Trademark information

NETAPP, the NETAPP logo, and the marks listed at <http://www.netapp.com/TM> are trademarks of NetApp, Inc. Other company and product names may be trademarks of their respective owners.