



SG5600 storage appliances

StorageGRID

NetApp
March 10, 2025

Table of Contents

- SG5600 storage appliances 1
 - StorageGRID appliance overview 1
 - StorageGRID appliance features 2
 - Hardware diagrams 3
 - Installation and deployment overview 6
 - Preparing for installation 7
 - Preparing the site (SG5600) 7
 - Unpacking the boxes (SG5600) 8
 - Obtaining additional equipment and tools (SG5600) 10
 - Service laptop requirements 12
 - Web browser requirements 12
 - Reviewing appliance network connections 12
 - Gathering installation information (SG5600) 17
 - Installing the hardware 21
 - Registering the hardware 22
 - Installing the appliance in a cabinet or rack (SG5600) 22
 - Cabling the appliance (SG5600) 24
 - Connecting the AC power cords (SG5600) 27
 - Turning power on (SG5600) 28
 - Viewing boot-up status and reviewing error codes on the SG5600 controllers 29
 - Configuring the hardware 33
 - Configuring StorageGRID connections 33
 - Configuring SANtricity Storage Manager 54
 - Optional: Enabling node encryption 60
 - Optional: Changing to RAID6 mode (SG5660 only) 62
 - Optional: Remapping network ports for the appliance 62
 - Deploying an appliance Storage Node 63
 - Monitoring the storage appliance installation 67
 - Automating appliance installation and configuration 68
 - Automating appliance configuration using the StorageGRID Appliance Installer 69
 - Automating installation and configuration of appliance nodes using the configure-sga.py script 72
 - Automating the configuration of StorageGRID 75
 - Overview of installation REST APIs 76
 - StorageGRID Installation API 77
 - StorageGRID Appliance Installer API 77
 - Troubleshooting the hardware installation 78
 - Hardware setup appears to hang 78
 - Troubleshooting connection issues 79
 - Rebooting the controller while the StorageGRID Appliance Installer is running 80
 - Maintaining the SG5600 appliance 80
 - Placing an appliance into maintenance mode 81
 - Upgrading SANtricity OS on the storage controllers using the Grid Manager 84
 - Upgrading SANtricity OS on the E2700 controller using maintenance mode 91

Upgrading drive firmware using SANtricity Storage Manager	92
Replacing the E2700 controller	97
Replacing the E5600SG controller	100
Replacing other hardware components	102
Changing the link configuration of the E5600SG controller	103
Changing the MTU setting	105
Checking the DNS server configuration	107
Monitoring node encryption in maintenance mode	109

SG5600 storage appliances

Learn how to install and maintain StorageGRID SG5612 and SG5660 appliances.

- [StorageGRID appliance overview](#)
- [Installation and deployment overview](#)
- [Preparing for installation](#)
- [Installing the hardware](#)
- [Configuring the hardware](#)
- [Deploying an appliance Storage Node](#)
- [Monitoring the storage appliance installation](#)
- [Automating appliance installation and configuration](#)
- [Overview of installation REST APIs](#)
- [Troubleshooting the hardware installation](#)
- [Maintaining the SG5600 appliance](#)

StorageGRID appliance overview

The StorageGRID SG5600 appliance is an integrated storage and computing platform that operates as a Storage Node in a StorageGRID grid.

The StorageGRID SG5600 appliance includes the following components:

Component	Description
E5600SG controller	<p>Compute serverThe E5600SG controller runs the Linux operating system and the StorageGRID software.</p> <p>This controller connects to the following:</p> <ul style="list-style-type: none">• The Admin, Grid, and Client Networks for the StorageGRID system• The E2700 controller, using dual SAS paths (active/active) with the E5600SG controller operating as the initiator

Component	Description
E2700 controller	<p>Storage controllerThe E2700 controller operates as a standard E-Series storage array in simplex mode, and runs the SANtricity operating system (controller firmware).</p> <p>This controller connects to the following:</p> <ul style="list-style-type: none"> • The management network where SANtricity Storage Manager is installed • The E5600SG controller, using dual SAS paths (active/active) with the E2700 controller operating as the target

The SG5600 appliance also includes the following components, depending on the model:

Component	Model SG5612	Model SG5660
Drives	12 NL-SAS drives	60 NL-SAS drives
Enclosure	DE1600 enclosure, a two rack-unit (2U) chassis that houses the drives and the controllers	DE6600 enclosure, a four rack-unit (4U) chassis that houses the drives and the controllers
Power supplies and fans	Two power-fan canisters	Two power supplies and two fans



The E5600SG controller is highly customized for use in the StorageGRID appliance. All other components operate as described in E-Series documentation, except as indicated in these instructions.

The maximum raw storage available on each StorageGRID appliance Storage Node is fixed, based on the appliance model and configuration. You cannot expand the available storage by adding a shelf with additional drives.

StorageGRID appliance features

The StorageGRID SG5600 appliance provides an integrated storage solution for creating a new StorageGRID system or for expanding the capacity of an existing system.

The StorageGRID appliance provides the following features:

- Combines the StorageGRID Storage Node computing and storage elements into a single, efficient, integrated solution
- Simplifies the installation and configuration of a Storage Node, automating most of the process required
- Provides a high-density storage solution with two enclosure options: one that is 2U and one that is 4U
- Uses 10-GbE IP interfaces directly to the Storage Node, without the need for intermediate storage interfaces such as FC or iSCSI

- Can be used in a hybrid grid environment that uses StorageGRID appliances and virtual (software-based) Storage Nodes
- Includes preconfigured storage and comes preloaded with the StorageGRID Appliance Installer (on the E5600SG controller) for field-ready software deployment and integration

Hardware diagrams

The SG5612 and SG5660 models of the StorageGRID appliance both include an E2700 controller and an E5600SG controller. You should review the diagrams to learn the differences between the models and the controllers.

Model SG5612 2U: Rear view of the E2700 controller and E5600SG controller



	Description
1	E2700 controller
2	E5600SG controller

Model SG5660 4U: Rear view of the E2700 controller and E5600SG controller

The E2700 controller is above the E5600SG controller.

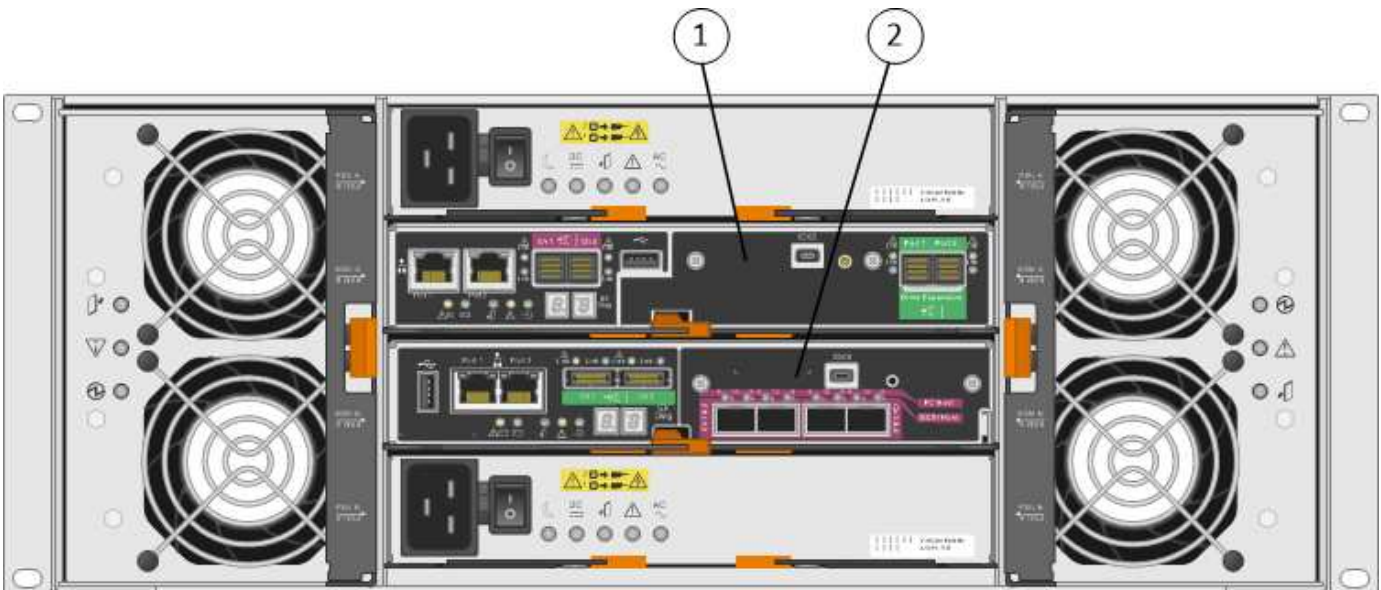

	Description
1	E2700 controller
2	E5600SG controller

Rear view of the E2700 controller

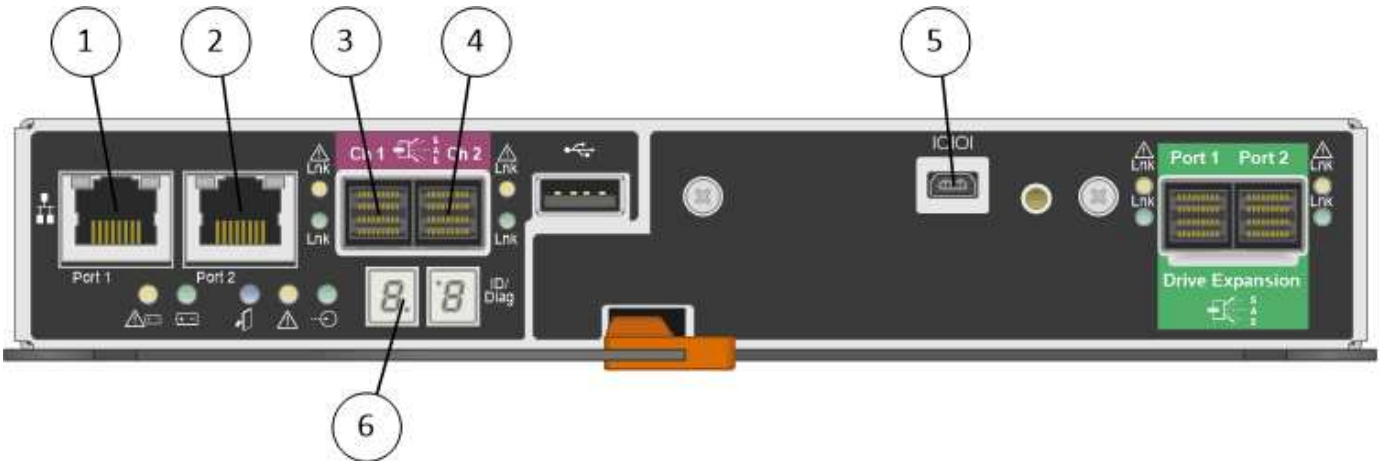

	Description
1	Management port 1 (Connect to the network where SANtricity Storage Manager is installed.)
2	Management port 2 (Use during installation to connect to a laptop.)
3	SAS interconnect port 1
4	SAS interconnect port 2
5	Serial connection port
6	Seven-segment display



The two SAS ports labeled Drive Expansion (green) on the rear of the E2700 controller are not used. The StorageGRID appliance does not support expansion drive shelves.

Rear view of the E5600SG controller

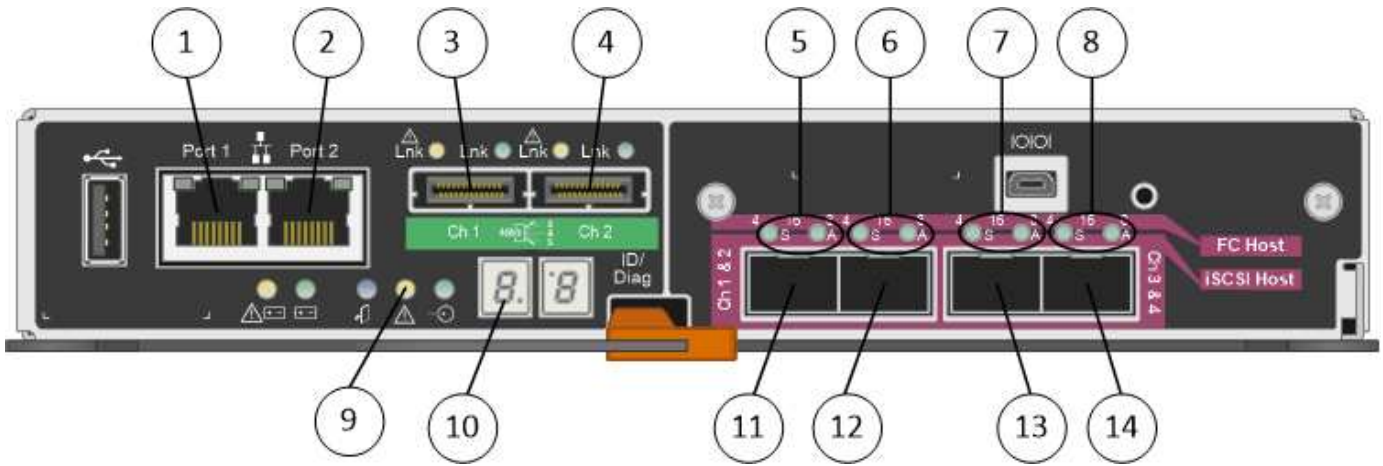

	Description
1	Management port 1 (Connect to the Admin network for StorageGRID.)
2	Management port 2 Options: <ul style="list-style-type: none"> • Bond with management port 1 for a redundant connection to the Admin Network for StorageGRID. • Leave unwired and available for temporary local access (IP 169.254.0.1). • During installation, use for IP configuration if DHCP-assigned IP addresses are not available.
3	SAS interconnect port 1
4	SAS interconnect port 2
5	Fault and Active LEDs for 10-GbE network port 1
6	Fault and Active LEDs for 10-GbE network port 2
7	Fault and Active LEDs for 10-GbE network port 3
8	Fault and Active LEDs for 10-GbE network port 4
9	Needs Attention LED
10	Seven-segment display
11	10-GbE network port 1
12	10-GbE network port 2
13	10-GbE network port 3

	Description
14	10-GbE network port 4



The host interface card (HIC) on the StorageGRID appliance E5600SG controller supports only 10-Gb Ethernet connections. It cannot be used for iSCSI connections.

Installation and deployment overview

You can install one or more StorageGRID appliances when you first deploy StorageGRID, or you can add appliance Storage Nodes later as part of an expansion. You might also need to install an appliance Storage Node as part of a recovery operation.

Adding a StorageGRID storage appliance to a StorageGRID system includes four primary steps:

1. Preparing for installation:
 - Preparing the installation site
 - Unpacking the boxes and checking the contents
 - Obtaining additional equipment and tools
 - Gathering IP addresses and network information
 - Optional: Configuring an external key management server (KMS) if you plan to encrypt all appliance data. See details about external key management in the instructions for administering StorageGRID.
2. Installing the hardware:
 - Registering the hardware
 - Installing the appliance into a cabinet or rack
 - Installing the drives (SG5660 only)
 - Cabling the appliance
 - Connecting the power cords and applying power
 - Viewing boot-up status codes
3. Configuring the hardware:
 - Accessing SANtricity Storage Manager, setting a static IP address for management port 1 on the E2700 controller, and configuring SANtricity Storage Manager settings
 - Accessing StorageGRID Appliance Installer and configuring the link and network IP settings required to connect to StorageGRID networks
 - Optional: Enabling node encryption if you plan to use an external KMS to encrypt appliance data.
 - Optional: Changing the RAID mode.
4. Deploying the appliance as a Storage Node:

Task	Refer to
Deploying an appliance Storage Node in a new StorageGRID system	Deploying an appliance Storage Node

Task	Refer to
Adding an appliance Storage Node to an existing StorageGRID system	Instructions for expanding a StorageGRID system
Deploying an appliance Storage Node as part of a Storage Node recovery operation	Instructions for recovery and maintenance

Related information

[Preparing for installation](#)

[Installing the hardware](#)

[Configuring the hardware](#)

[Expand your grid](#)

[Maintain & recover](#)

[Administer StorageGRID](#)

Preparing for installation

Preparing to install a StorageGRID appliance entails preparing the site and obtaining all required hardware, cables, and tools. You should also gather IP addresses and network information.

Steps

- [Preparing the site \(SG5600\)](#)
- [Unpacking the boxes \(SG5600\)](#)
- [Obtaining additional equipment and tools \(SG5600\)](#)
- [Service laptop requirements](#)
- [Web browser requirements](#)
- [Reviewing appliance network connections](#)
- [Gathering installation information \(SG5600\)](#)

Preparing the site (SG5600)

Before installing the appliance, you must make sure that the site and the cabinet or rack you plan to use meet the specifications for a StorageGRID appliance.

Steps

1. Confirm that the site meets the requirements for temperature, humidity, altitude range, airflow, heat dissipation, wiring, power, and grounding. See the NetApp Hardware Universe for more information.
2. Obtain a 19-inch (48.3-cm) cabinet or rack to fit shelves of this size (without cables):

Appliance model	Height	Width	Depth	Maximum weight
SG5612 (12 drives)	3.40 in. (8.64 cm)	19.0 in. (48.26 cm)	21.75 in. (55.25 cm)	59.5 lb (27 kg)
SG5660 (60 drives)	7.00 in. (17.78 cm)	17.75 in. (45.08 cm)	32.50 in. (82.55 cm)	236.2 lb. (107.1 kg)

3. Install any required network switches. See the NetApp Interoperability Matrix Tool for compatibility information.

Related information

[NetApp Hardware Universe](#)

[NetApp Interoperability](#)

Unpacking the boxes (SG5600)

Before installing the StorageGRID appliance, unpack all boxes and compare the contents to the items on the packing slip.

- **SG5660 enclosure, a 4U chassis with 60 drives**



- **SG5612 enclosure, a 2U chassis with 12 drives**



- **4U bezel or 2U endcaps**



- **NL-SAS drives**

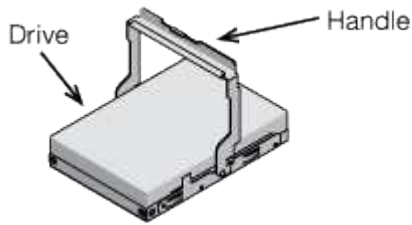

Drives are preinstalled in the 2U SG5612, but not in the 4U SG5660 for shipment safety.

- **E5600SG controller**



- **E2700 controller**



- **Mounting rails and screws**



- **Enclosure handles (4U enclosures only)**

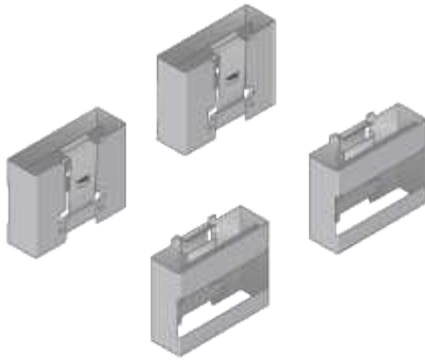

Cables and connectors

The shipment for the StorageGRID appliance includes the following cables and connectors:

- **Power cords for your country**



The appliance ships with two AC power cords for connecting to an external power source, such as a wall plug. Your cabinet might have special power cords that you use instead of the power cords that ship with the appliance.

- **SAS interconnect cables**



Two 0.5-meter SAS interconnect cables with mini-SAS-HD and mini-SAS connectors.

The square connector plugs into the E2700 controller, and the rectangular connector plugs into the E5600SG controller.

Obtaining additional equipment and tools (SG5600)

Before installing the SG5600 appliance, confirm you have all of the additional equipment and tools that you need.

- **Screwdrivers**



Phillips No. 2 screwdriver

Medium flat-blade screwdrivers

- **ESD wrist strap**



- **Ethernet cables**



- **Ethernet switch**



- **Service laptop**



Service laptop requirements

Before you install the StorageGRID appliance hardware, you should check to see if the service laptop has the minimum required resources.

The service laptop, which is needed for the hardware installation, must meet the following requirements:

- Microsoft Windows operating system
- Network port
- Supported web browser
- NetApp SANtricity Storage Manager version 11.40 or later
- SSH client (for example, PuTTY)

Related information

[Web browser requirements](#)

[NetApp Documentation: SANtricity Storage Manager](#)

Web browser requirements

You must use a supported web browser.

Web browser	Minimum supported version
Google Chrome	87
Microsoft Edge	87
Mozilla Firefox	84

You should set the browser window to a recommended width.

Browser width	Pixels
Minimum	1024
Optimum	1280

Reviewing appliance network connections

Before installing the StorageGRID appliance, you should understand which networks can be connected to the appliance and how the ports on each controller are used.

StorageGRID appliance networks

When you deploy a StorageGRID appliance as a Storage Node, you can connect it to the following networks:

- **Grid Network for StorageGRID:** The Grid Network is used for all internal StorageGRID traffic. It provides

connectivity between all nodes in the grid, across all sites and subnets. The Grid Network is required.

- **Admin Network for StorageGRID:** The Admin Network is a closed network used for system administration and maintenance. The Admin Network is typically a private network and does not need to be routable between sites. The Admin Network is optional.
- **Client Network for StorageGRID:** The Client Network is an open network used to provide access to client applications, including S3 and Swift. The Client Network provides client protocol access to the grid, so the Grid Network can be isolated and secured. The Client Network is optional.
- **Management network for SANtricity Storage Manager:** The E2700 controller connects to the management network where SANtricity Storage Manager is installed, allowing you to monitor and manage the hardware components in the appliance. This management network can be the same as the Admin Network for StorageGRID, or it can be an independent management network.



For detailed information about StorageGRID networks, see the *Grid Primer*.

StorageGRID appliance connections

When you install a StorageGRID appliance, you must connect the two controllers to each other and to the required networks. The figure shows the two controllers in the SG5660, with the E2700 controller on the top and the E5600SG controller on the bottom. In the SG5612, the E2700 controller is to the left of the E5600SG controller.

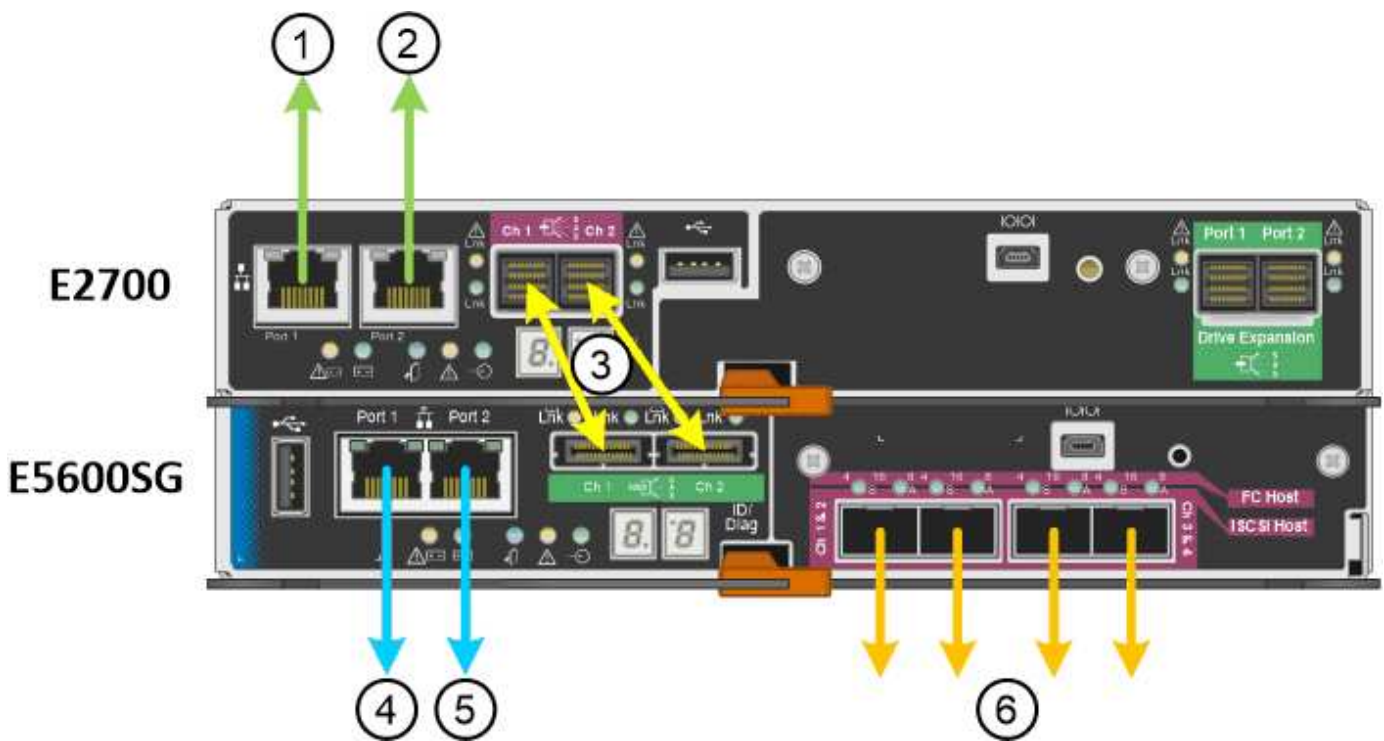

Item	Port	Type of port	Function
1	Management port 1 on the E2700 controller	1-Gb (RJ-45) Ethernet	Connects the E2700 controller to the network where SANtricity Storage Manager is installed.

Item	Port	Type of port	Function
2	Management port 2 on the E2700 controller	1-Gb (RJ-45) Ethernet	Connects the E2700 controller to a service laptop during installation.
3	Two SAS interconnect ports on each controller, labelled Ch 1 and Ch 2	E2700 controller: mini-SAS-HD E5600SG controller: mini-SAS	Connect the two controllers to each other.
4	Management port 1 on the E5600SG controller	1-Gb (RJ-45) Ethernet	Connects the E5600SG controller to the Admin Network for StorageGRID.
5	Management port 2 on the E5600SG controller	1-Gb (RJ-45) Ethernet	<ul style="list-style-type: none"> • Can be bonded with management port 1 if you want a redundant connection to the Admin Network. • Can be left unwired and available for temporary local access (IP 169.254.0.1). • Can be used to connect the E5600SG controller to a service laptop during installation, if a DHCP-assigned IP address is not available.
6	Four network ports on the E5600SG controller	10-GbE (optical)	Connect to the Grid Network and the Client Network for StorageGRID. See “10-GbE port connections for the E5600SG controller.”

Related information

[Port bond modes for the E5600SG controller ports](#)

[Gathering installation information \(SG5600\)](#)

[Cabling the appliance \(SG5600\)](#)

[Network guidelines](#)

[Install VMware](#)

[Install Red Hat Enterprise Linux or CentOS](#)

[Install Ubuntu or Debian](#)

Port bond modes for the E5600SG controller ports

When configuring network links for the E5600SG controller ports, you can use port bonding for the 10-GbE ports that connect to the Grid Network and optional Client Network, and the 1-GbE management ports that connect to the optional Admin Network. Port bonding helps protect your data by providing redundant paths between StorageGRID networks and the appliance.

Related information

[Configuring network links \(SG5600\)](#)

Network bond modes for the 10-GbE ports

The 10-GbE networking ports on the E5600SG controller support Fixed port bond mode or Aggregate port bond mode for the Grid Network and Client Network connections.

Fixed port bond mode

Fixed mode is the default configuration for the 10-GbE networking ports.

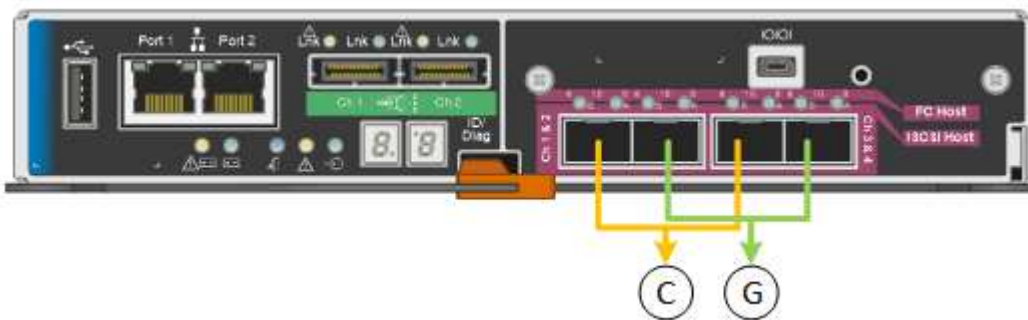

	Which ports are bonded
C	Ports 1 and 3 are bonded together for the Client Network, if this network is used.
G	Ports 2 and 4 are bonded together for the Grid Network.

When using Fixed port bond mode, the ports can be bonded using active-backup mode or Link Aggregation Control Protocol mode (LACP 802.3ad).

- In active-backup mode (default), only one port is active at a time. If the active port fails, its backup port automatically provides a failover connection. Port 4 provides a backup path for port 2 (Grid Network), and port 3 provides a backup path for port 1 (Client Network).
- In LACP mode, each pair of ports forms a logical channel between the controller and the network, allowing for higher throughput. If one port fails, the other port continues to provide the channel. Throughput is reduced, but connectivity is not impacted.



If you do not need redundant connections, you can use only one port for each network. However, be aware that an alarm will be raised in the Grid Manager after StorageGRID is installed, indicating that a cable is unplugged. You can safely acknowledge this alarm to clear it.

Aggregate port bond mode

Aggregate port bond mode significantly increases the throughput for each StorageGRID network and provides additional failover paths.

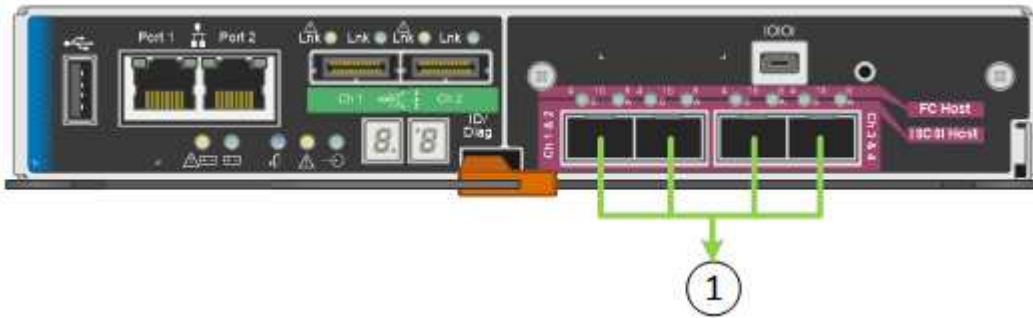

	Which ports are bonded
1	All connected ports are grouped in a single LACP bond, allowing all ports to be used for Grid Network and Client Network traffic.

If you plan to use Aggregate port bond mode:

- You must use LACP network bond mode.
- You must specify a unique VLAN tag for each network. This VLAN tag will be added to each network packet to ensure that network traffic is routed to the correct network.
- The ports must be connected to switches that can support VLAN and LACP. If multiple switches are participating in the LACP bond, the switches must support multi-chassis link aggregation groups (MLAG), or equivalent.
- You must understand how to configure the switches to use VLAN, LACP, and MLAG, or equivalent.

If you do not want to use all four 10-GbE ports, you can use one, two, or three ports. Using more than one port maximizes the chance that some network connectivity will remain available if one of the 10-GbE ports fails.



If you choose to use fewer than four ports, be aware that one or more alarms will be raised in the Grid Manager after StorageGRID is installed, indicating that cables are unplugged. You can safely acknowledge the alarms to clear them.

Network bond modes for the 1-GbE management ports

For the two 1-GbE management ports on the E5600SG controller, you can choose Independent network bond mode or Active-Backup network bond mode to connect to the optional Admin Network.

In Independent mode, only management port 1 is connected to the Admin Network. This mode does not provide a redundant path. Management port 2 is left unwired and available for temporary local connections (use IP address 169.254.0.1)

In Active-Backup mode, both management ports 1 and 2 are connected to the Admin Network. Only one port is active at a time. If the active port fails, its backup port automatically provides a failover connection. Bonding these two physical ports into one logical management port provides a redundant path to the Admin Network.



If you need to make a temporary local connection to the E5600SG controller when the 1-GbE management ports are configured for Active-Backup mode, remove the cables from both management ports, plug your temporary cable into management port 2, and access the appliance using IP address 169.254.0.1.



Gathering installation information (SG5600)

As you install and configure the StorageGRID appliance, you must make decisions and gather information about Ethernet switch ports, IP addresses, and port and network bond modes.

About this task

You can use the following tables to record information for each network you connect to the appliance. These values are required to install and configure the hardware.

Information needed to connect the E2700 controller to SANtricity Storage Manager

You must connect the E2700 controller to the management network you will use for SANtricity Storage Manager.

Information needed	Your value
Ethernet switch port you will connect to management port 1	
MAC address for management port 1 (printed on a label near port P1)	
DHCP-assigned IP address for management port 1, if available after power on Note: If the network you will connect to the E2700 controller includes a DHCP server, the network administrator can use the MAC address to determine the IP address that was assigned by the DHCP server.	

Information needed	Your value
Speed and duplex mode Note: You must make sure the Ethernet switch for the SANtricity Storage Manager management network is set to autonegotiate.	Must be: <ul style="list-style-type: none"> • Autonegotiate (default)
IP address format	Choose one: <ul style="list-style-type: none"> • IPv4 • IPv6
Static IP address you plan to use for the appliance on the management network	For IPv4: <ul style="list-style-type: none"> • IPv4 address: • Subnet mask: • Gateway: For IPv6: <ul style="list-style-type: none"> • IPv6 address: • Routable IP address: • E2700 controller router IP address:

Information needed to connect the E5600SG controller to the Admin Network

The Admin Network for StorageGRID is an optional network, used for system administration and maintenance. The appliance connects to the Admin Network using the 1-GbE management ports on the E5600SG controller.

Information needed	Your value
Admin Network enabled	Choose one: <ul style="list-style-type: none"> • No • Yes (default)
Network bond mode	Choose one: <ul style="list-style-type: none"> • Independent • Active-Backup
Switch port for management port 1 (P1)	
Switch port for management port 2 (P2; Active-Backup network bond mode only)	

Information needed	Your value
MAC address for management port 1 (printed on a label near port P1)	
DHCP-assigned IP address for management port 1, if available after power on Note: If the Admin Network includes a DHCP server, the E5600SG controller displays the DHCP-assigned IP address on its seven-segment display after it boots up. You can also determine the DHCP-assigned IP address by using the MAC address to look up the assigned IP.	<ul style="list-style-type: none"> • IPv4 address (CIDR): • Gateway:
Static IP address you plan to use for the appliance Storage Node on the Admin Network Note: If your network does not have a gateway, specify the same static IPv4 address for the gateway.	<ul style="list-style-type: none"> • IPv4 address (CIDR): • Gateway:
Admin Network subnets (CIDR)	

Information needed to connect and configure the 10-GbE ports on the E5600SG controller

The four 10-GbE ports on the E5600SG controller connect to the StorageGRID Grid Network and Client Network.



See "10-GbE port connections for the E5600SG controller" for more information about the options for these ports.

Information needed	Your value
Port bond mode	Choose one: <ul style="list-style-type: none"> • Fixed (default) • Aggregate
Switch port for port 1 (Client Network for Fixed mode)	
Switch port for port 2 (Grid Network for Fixed mode)	
Switch port for port 3 (Client Network for Fixed mode)	
Switch port for port 4 (Grid Network for Fixed mode)	

Information needed to connect the E5600SG controller to the Grid Network

The Grid Network for StorageGRID is a required network, used for all internal StorageGRID traffic. The appliance connects to the Grid Network using the 10-GbE ports on the E5600SG controller.



See "10-GbE port connections for the E5600SG controller" for more information about the options for these ports.

Information needed	Your value
Network bond mode	Choose one: <ul style="list-style-type: none">• Active-Backup (default)• LACP (802.3ad)
VLAN tagging enabled	Choose one: <ul style="list-style-type: none">• No (default)• Yes
VLAN tag(if VLAN tagging is enabled)	Enter a value between 0 and 4095:
DHCP-assigned IP address for the Grid Network, if available after power on Note: If the Grid Network includes a DHCP server, the E5600SG controller displays the DHCP-assigned IP address for the Grid Network on its seven-segment display after it boots up.	<ul style="list-style-type: none">• IPv4 address (CIDR):• Gateway:
Static IP address you plan to use for the appliance Storage Node on the Grid Network Note: If your network does not have a gateway, specify the same static IPv4 address for the gateway.	<ul style="list-style-type: none">• IPv4 address (CIDR):• Gateway:
Grid Network subnets (CIDR) Note: If the Client Network is not enabled, the default route on the controller will use the gateway specified here.	

Information needed to connect the E5600SG controller to the Client Network

The Client Network for StorageGRID is an optional network, used to provides client protocol access to the grid. The appliance connects to the Client Network using the 10-GbE ports on the E5600SG controller.



See "10-GbE port connections for the E5600SG controller" for more information about the options for these ports.

Information needed	Your value
Client Network enabled	Choose one: <ul style="list-style-type: none"> • No (default) • Yes
Network bond mode	Choose one: <ul style="list-style-type: none"> • Active-Backup (default) • LACP (802.3ad)
VLAN tagging enabled	Choose one: <ul style="list-style-type: none"> • No (default) • Yes
VLAN tag(if VLAN tagging is enabled)	Enter a value between 0 and 4095:
DHCP-assigned IP address for the Client Network, if available after power on	<ul style="list-style-type: none"> • IPv4 address (CIDR): • Gateway:
Static IP address you plan to use for the appliance Storage Node on the Client Network Note: If the Client Network is enabled, the default route on the controller will use the gateway specified here.	<ul style="list-style-type: none"> • IPv4 address (CIDR): • Gateway:

Related information

[Reviewing appliance network connections](#)

[Configuring the hardware](#)

[Port bond modes for the E5600SG controller ports](#)

Installing the hardware

Hardware installation includes several major tasks, including installing hardware components, cabling those components, and configuring ports.

Steps

- [Registering the hardware](#)
- [Installing the appliance in a cabinet or rack \(SG5600\)](#)
- [Cabling the appliance \(SG5600\)](#)
- [Connecting the AC power cords \(SG5600\)](#)

- Turning power on (SG5600)
- Viewing boot-up status and reviewing error codes on the SG5600 controllers

Registering the hardware

Registering the appliance hardware provides support benefits.

Steps

1. Locate the chassis serial number.

You can find the number on the packing slip, in your confirmation email, or on the appliance after you unpack it.



2. Go to the NetApp Support Site at mysupport.netapp.com.
3. Determine whether you need to register the hardware:

If you are a...	Follow these steps...
Existing NetApp customer	<ol style="list-style-type: none"> a. Sign in with your username and password. b. Select Products > My Products. c. Confirm that the new serial number is listed. d. If it is not, follow the instructions for new NetApp customers.
New NetApp customer	<ol style="list-style-type: none"> a. Click Register Now, and create an account. b. Select Products > Register Products. c. Enter the product serial number and requested details. <p>After your registration is approved, you can download any required software. The approval process might take up to 24 hours.</p>

Installing the appliance in a cabinet or rack (SG5600)

You must install rails in your cabinet or rack and then slide the appliance onto the rails. If you have an SG5660, you must also install the drives after installing the appliance.

What you'll need

- You have reviewed the Safety Notices document included in the box, and understand the precautions for moving and installing hardware.
- You have the E-Series installation instructions for the hardware.



Install hardware from the bottom of the rack or cabinet or rack up to prevent the equipment from tipping over.



The SG5612 weighs approximately 60 lb (27 kg) when fully loaded with drives. Two people or a mechanized lift are required to safely move the SG5612.



The SG5660 weighs approximately 132 lb (60 kg) with no drives installed. Four people or a mechanized lift are required to safely move an empty SG5660.



To avoid damaging the hardware, never move an SG5660 if drives are installed. You must remove all drives before moving the appliance.

About this task

Complete the following tasks to install the SG5660 appliance in a cabinet or rack.

- **Install the mounting rails**

Install the mounting rails in the cabinet or rack.

See the E-Series installation instructions for the E2700 or the E5600.

- **Install the appliance in the cabinet or rack**

Slide the appliance into the cabinet or rack, and secure it.



If you are lifting the SG5660 by hand, attach the four handles to the sides of the chassis. You remove these handles as you slide the appliance onto the rails.

- **Install the drives**

If you have an SG5660, install 12 drives in each of the 5 drive drawers.

You must install all 60 drives to ensure correct operation.

- a. Put on the ESD wristband, and remove the drives from their packaging.
- b. Release the levers on the top drive drawer, and slide the drawer out using the levers.
- c. Raise the drive handle to vertical, and align the buttons on the drive with the notches on the drawer.

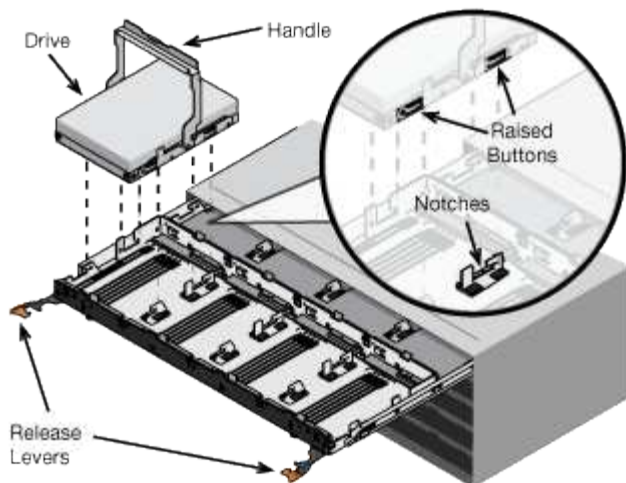

- d. Pressing gently on the top of the drive, rotate the drive handle down until the drive snaps into place.
- e. After installing the first 12 drives, slide the drawer back in by pushing on the center and closing both levers gently.
- f. Repeat these steps for the other four drawers.

- **Attach the front bezel**

SG5612: Attach the left and right end caps to the front.

SG5660: Attach the bezel to the front.

Related information

[E2700 Controller-Drive Tray and Related Drive Trays Installation Guide](#)

[E5600 Controller-Drive Tray and Related Drive Trays Installation Guide](#)

Cabling the appliance (SG5600)

You must connect the two controllers to each other with SAS interconnect cables, connect the management ports to the appropriate management network, and connect the 10 GbE ports on the E5600SG controller to the Grid Network and optional Client Network for StorageGRID.

What you'll need

- You have Ethernet cables for connecting the management ports.
- You have optical cables for connecting the four 10-GbE ports (these are not provided with the appliance).



Risk of exposure to laser radiation — Do not disassemble or remove any part of an SFP transceiver. You might be exposed to laser radiation.

About this task

When connecting the cables, refer to the following diagram, which shows the E2700 controller on the top and the E5600SG controller on the bottom. The diagram shows the SG5660 model; the controllers in the SG5612 model are side by side instead of stacked.

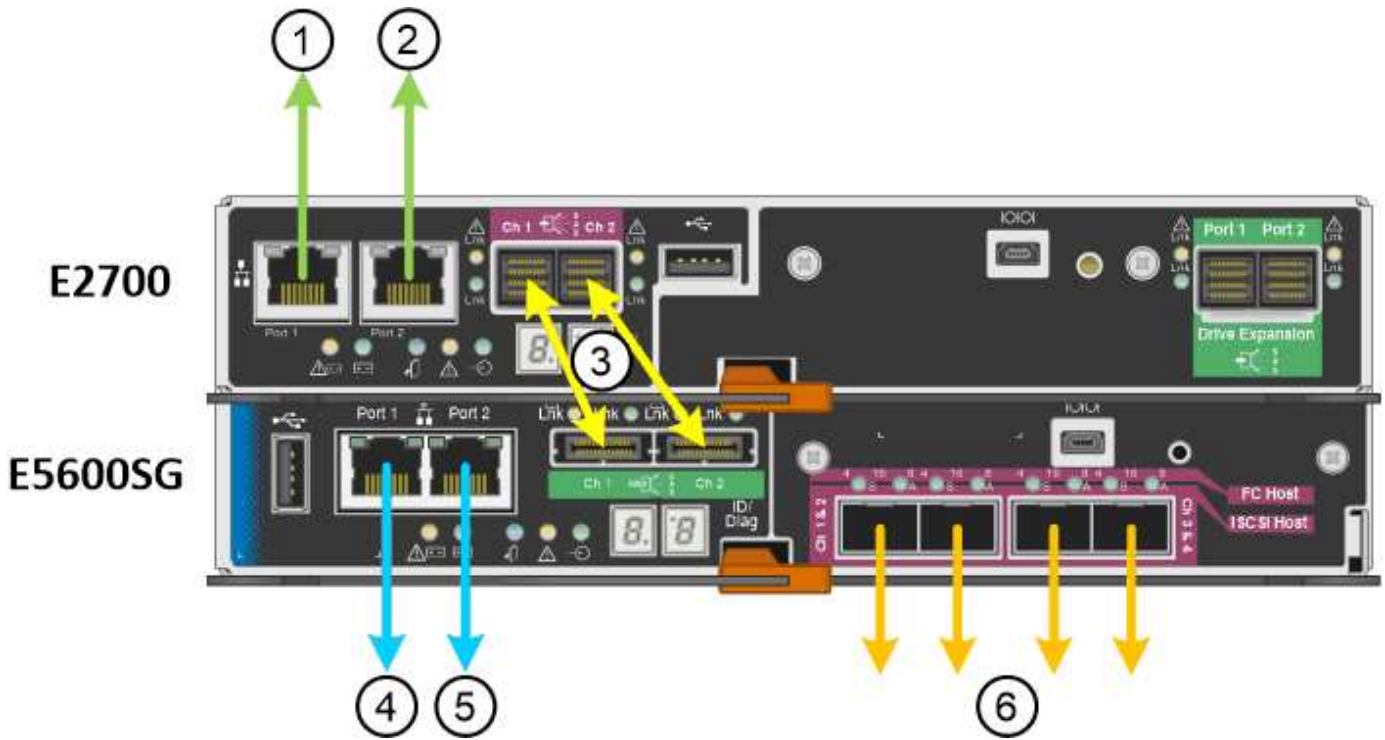

Item	Port	Type of port	Function
1	Management port 1 on the E2700 controller	1-Gb (RJ-45) Ethernet	Connects the E2700 controller to the network where SANtricity Storage Manager is installed.
2	Management port 2 on the E2700 controller	1-Gb (RJ-45) Ethernet	Connects the E2700 controller to a service laptop during installation.
3	Two SAS interconnect ports on each controller, labelled Ch 1 and Ch 2	E2700 controller: mini-SAS-HD E5600SG controller: mini-SAS	Connect the two controllers to each other.
4	Management port 1 on the E5600SG controller	1-Gb (RJ-45) Ethernet	Connects the E5600SG controller to the Admin Network for StorageGRID.

Item	Port	Type of port	Function
5	Management port 2 on the E5600SG controller	1-Gb (RJ-45) Ethernet	<ul style="list-style-type: none"> • Can be bonded with management port 1 if you want a redundant connection to the Admin Network. • Can be left unwired and available for temporary local access (IP 169.254.0.1). • Can be used to connect the E5600SG controller to a service laptop during installation if DHCP-assigned IP addresses are not available.
6	Four network ports on the E5600SG controller	10-GbE (optical)	Connect the E5600SG controller to the Grid Network and to the Client Network (if used) for StorageGRID. The ports can be bonded together to provide redundant paths to the controller.

Steps

1. Connect the E2700 controller to the E5600SG controller, using the two SAS interconnect cables.

Connect this port...	To this port...
SAS interconnect port 1 (labeled Ch 1) on the E2700 controller	SAS interconnect port 1 (labeled Ch 1) on the E5600SG controller
SAS interconnect port 2 (labeled Ch 2) on the E2700 controller	SAS interconnect port 2 (labeled Ch 2) on the E5600SG controller

Use the square connector (mini-SAS HD) for the E2700 controller, and use the rectangular connector (mini-SAS) for the E5600SG controller.



Make sure the pull tabs on the SAS connectors are at the bottom, and carefully insert each connector until it clicks into place. Do not push on the connector if there is any resistance. Verify the position of the pull tab before continuing.

2. Connect the E2700 controller to the management network where SANtricity Storage Manager software is installed, using an Ethernet cable.

Connect this port...	To this port...
Port 1 on the E2700 controller (the RJ-45 port on the left)	Switch port on the management network used for SANtricity Storage Manager
Port 2 on the E2700 controller	Service laptop, if not using DHCP

3. If you plan to use the Admin Network for StorageGRID, connect the E5600SG controller, using an Ethernet cable.

Connect this port...	To this port...
Port 1 on the E5600SG controller (the RJ-45 port on the left)	Switch port on the Admin Network for StorageGRID
Port 2 on the E5600SG controller	Service laptop, if not using DHCP

4. Connect the 10-GbE ports on the E5600SG controller to the appropriate network switches, using optical cables and SFP+ transceivers.
- If you plan to use Fixed port bond mode (default), connect the ports to the StorageGRID Grid and Client Networks, as shown in the table.

Port	Connects to...
Port 1	Client Network (optional)
Port 2	Grid Network
Port 3	Client Network (optional)
Port 4	Grid Network

- If you plan to use the Aggregate port bond mode, connect one or more of the network ports to one or more switches. You should connect at least two of the four ports to avoid having a single point of failure. If you use more than one switch for a single LACP bond, the switches must support MLAG or equivalent.

Related information

[Port bond modes for the E5600SG controller ports](#)

[Accessing the StorageGRID Appliance Installer](#)

Connecting the AC power cords (SG5600)

You must connect the AC power cords to the external power source and to the AC power connector on each controller. After you have connected the power cords, you can turn the power on.

What you'll need

Both appliance power switches must be off before connecting power.



Risk of electrical shock — Before connecting the power cords, make sure that the two power switches on the appliance are off.

About this task

- You should use separate power sources for each power supply.

Connecting to independent power sources maintains power redundancy.

- You can use the power cords shipped with the controller with typical outlets used in the destination country, such as wall receptacles of an uninterrupted power supply (UPS).

However, these power cords are not intended for use in most EIA-compliant cabinets.

Steps

1. Turn off the power switches in the enclosure or chassis.
2. Turn off the power switches on the controllers.
3. Connect the primary power cords from the cabinet to the external power sources.
4. Connect the power cords to the AC power connector on each controller.

Turning power on (SG5600)

Powering on the enclosure provides power to both controllers.

Steps

1. Turn on the two power supply switches at the rear of the enclosure.

While the power is being applied, the LEDs on the controllers go on and off intermittently.

The power-on process can take up to ten minutes to complete. The controllers reboot several times during the initial startup sequence, which causes the fans to ramp up and down and the LEDs to flash.

2. Check the Power LED and the Host Link Active LEDs on each controller to verify that the power was turned on.
3. Wait for all drives to show a persistent green LED, indicating that they have come online.
4. Check for green LEDs on the front and rear of the enclosure.

If you see any amber LEDs, make a note of their locations.

5. Look at the seven-segment display for the E5600SG controller.

This display shows **HO**, followed by a repeating sequence of two digits.

```
HO -- IP address for Admin Network -- IP address for Grid Network HO
```

In the sequence, the first set of numbers is the DHCP-assigned IP address for the controller's management port 1. This address is used to connect the controller to the Admin Network for StorageGRID. The second

set of numbers is the DHCP-assigned IP address used to connect the appliance to the Grid Network for StorageGRID.



If an IP address could not be assigned using DHCP, 0.0.0.0 is displayed.

Viewing boot-up status and reviewing error codes on the SG5600 controllers

The seven-segment display on each controller shows status and error codes when the appliance powers up, while the hardware is initializing, and when the hardware fails and must back out of the initialization. If you are monitoring the progress or troubleshooting, you should watch the sequence of the codes as they appear.

About this task

The status and error codes for the E5600SG controller are not the same as those for the E2700 controller.

Steps

1. During boot-up, view the codes shown on the seven-segment displays to monitor progress.
2. To review error codes for the E5600SG controller, see the seven-segment display status and error code information.
3. To review error codes for the E2700 controller, see the E2700 controller documentation on the Support Site.

Related information

[E5600SG controller seven-segment display codes](#)

[NetApp Documentation: E2700 Series](#)

E5600SG controller seven-segment display codes

The seven-segment display on the E5600SG controller shows status and error codes while the appliance powers up and while the hardware is initializing. You can use these codes to determine status and troubleshoot errors.

When reviewing status and error codes on the E5600SG controller, you should look at the following types of codes:

- **General boot-up codes**

Represent the standard boot-up events.

- **Normal boot-up codes**

Represent the normal boot-up events that occur in the appliance.

- **Error codes**

Indicate issues during the boot-up events.

StorageGRID controls only the following LEDs on the E5600SG controller and only after the StorageGRID Appliance Installer has started:

- Service Action Allowed LED
- Service Action Required LED
- Seven-segment display

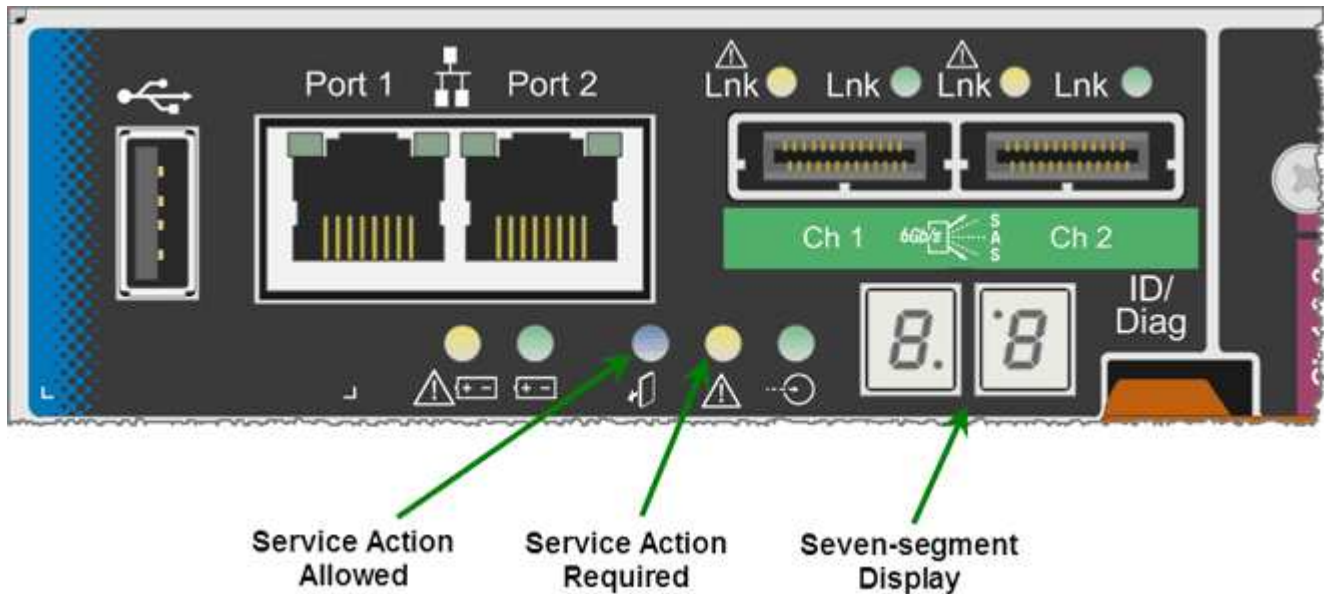

The decimal points on the seven-segment display are not used by the StorageGRID appliance:

- The upper decimal point adjacent to the least significant digit is the platform diagnostic LED. This is turned on during reset and initial hardware configuration. Otherwise, it is turned off.
- The lower decimal point adjacent to the most significant digit is turned off.

To diagnose other issues, you might want to look at these resources:

- To see all other hardware and environmental diagnostic information, see the E-Series operating system hardware diagnostics.

This includes looking for hardware issues such as power, temperature, and disk drives. The appliance relies on the E-Series operating system to monitor all platform environmental statuses.

- To determine firmware and driver issues, look at the link lights on the SAS and network ports.

For details, see the E-Series E5600 documentation.

General boot-up codes

During boot-up or after a hard reset of the hardware, the Service Action Allowed and the Service Action Required LEDs come on while the hardware is initializing. The seven-segment display shows a sequence of codes that are the same for E-Series hardware and not specific to the E5600SG controller.

During boot-up, the Field Programmable Gate Array (FPGA) controls the functions and initialization on the hardware.

Code	Indication
19	FPGA initialization.
68	FPGA initialization.
...	FPGA initialization. This is a quick succession of codes.
AA	Platform BIOS booting.
FF	Bios boot-up complete. This is an intermediate state before E5600SG controller initializes and manages LEDs to indicate status.

After the AA and FF codes appear, either the normal boot-up codes appear or error codes appear. Additionally, the Service Action Allowed and the Service Action Required LEDs are turned off.

Normal boot-up codes

These codes represent the normal boot-up events that occur in the appliance, in chronological order.

Code	Indication
HI	The master boot script has started.
PP	The platform FPGA firmware is checking for updates.
HP	The host interface card (HIC) is checking for updates.
RB	After firmware updates, the system is rebooting, if necessary.
FP	The firmware update checks have been completed. Starting the process (utmagent) to communicate with and manage the E2700 controller. This process facilitates appliance provisioning.
HE	The system is synchronizing with the E-Series operating system.
HC	The StorageGRID installation is being checked.
HO	Installation management and active interfacing are occurring.
HA	The Linux operating system and StorageGRID are running.

E5600SG controller error codes

These codes represent error conditions that might be shown on the E5600SG controller as the appliance boots up. Additional two-digit hexadecimal codes are displayed if specific low-level hardware errors occur. If any of these codes persists for more than a second or two, or if you are unable to resolve the error by following one of the prescribed troubleshooting procedures, contact technical support.

Code	Indication
22	No master boot record found on any boot device.
23	No SATA drive installed.
2A, 2B	Stuck bus, unable to read DIMM SPD data.
40	Invalid DIMMs.
41	Invalid DIMMs.
42	Memory test failed.
51	SPD reading failure.
92 to 96	PCI bus initialization.
A0 to A3	SATA drive initialization.
AB	Alternate boot code.
AE	Booting OS.
EA	DDR3 training failed.
E8	No memory installed.
EU	The installation script was not found.
EP	"ManageSGA" code indicates that pregrid communication with the E2700 controller failed.

Related information

[Troubleshooting the hardware installation](#)

[NetApp Support](#)

Configuring the hardware

After applying power to the appliance, you must configure SANtricity Storage Manager, which is the software you will use to monitor the hardware. You must also configure the network connections that will be used by StorageGRID.

Steps

- [Configuring StorageGRID connections](#)
- [Configuring SANtricity Storage Manager](#)
- [Optional: Enabling node encryption](#)
- [Optional: Changing to RAID6 mode \(SG5660 only\)](#)
- [Optional: Remapping network ports for the appliance](#)

Configuring StorageGRID connections

Before you can deploy a StorageGRID appliance as a Storage Node in a StorageGRID grid, you must configure the connections between the appliance and the networks you plan to use. You can configure networking by browsing to the StorageGRID Appliance Installer, which is included on the E5600SG controller (the compute controller in the appliance).

Steps

- [Accessing the StorageGRID Appliance Installer](#)
- [Verifying and upgrading the StorageGRID Appliance Installer version](#)
- [Configuring network links \(SG5600\)](#)
- [Setting the IP configuration](#)
- [Verifying network connections](#)
- [Verifying port-level network connections](#)

Accessing the StorageGRID Appliance Installer

You must access the StorageGRID Appliance Installer to configure the connections between the appliance and the three StorageGRID networks: the Grid Network, the Admin Network (optional), and the Client Network (optional).

What you'll need

- You are using a supported web browser.
- The appliance is connected to all of the StorageGRID networks you plan to use.
- You know the IP address, gateway, and subnet for the appliance on these networks.
- You have configured the network switches you plan to use.

About this task

When you first access the StorageGRID Appliance Installer, you can use the DHCP-assigned IP address for the Admin Network (assuming the appliance is connected to the Admin Network) or the DHCP-assigned IP address for the Grid Network. Using the IP address for the Admin Network is preferred. Otherwise, if you

access the StorageGRID Appliance Installer using the DHCP address for the Grid Network, you might lose connection with the StorageGRID Appliance Installer when you change link settings and when you enter a static IP.

Steps

1. Obtain the DHCP address for the appliance on the Admin Network (if it is connected) or the Grid Network (if the Admin Network is not connected).

You can do either of the following:

- Provide the MAC address for management port 1 to your network administrator, so they can look up the DHCP address for this port on the Admin Network. The MAC address is printed on a label on the E5600SG controller, next to the port.
- Look at the seven-segment display on the E5600SG controller. If management port 1 and 10-GbE ports 2 and 4 on the E5600SG controller are connected to networks with DHCP servers, the controller attempts to obtain dynamically assigned IP addresses when you power on the enclosure. After the controller has completed the power-on process, its seven-segment display shows **HO**, followed by a repeating sequence of two numbers.

```
HO -- IP address for Admin Network -- IP address for Grid Network HO
```

In the sequence:

- The first set of numbers is the DHCP address for the appliance Storage Node on the Admin Network, if it is connected. This IP address is assigned to management port 1 on the E5600SG controller.
- The second set of numbers is the DHCP address for the appliance Storage Node on the Grid Network. This IP address is assigned to 10-GbE ports 2 and 4 when you first apply power to the appliance.



If an IP address could not be assigned using DHCP, 0.0.0.0 is displayed.

2. If you were able to obtain either of the DHCP addresses:

- a. Open a web browser on the service laptop.
- b. Enter this URL for the StorageGRID Appliance Installer:

`https://E5600SG_Controller_IP:8443`

For *E5600SG_Controller_IP*, use the DHCP address for the controller (use the IP address for the Admin Network if you have it).

- c. If you are prompted with a security alert, view and install the certificate using the browser's installation wizard.

The alert will not appear the next time you access this URL.

The StorageGRID Appliance Installer Home page appears. The information and messages shown when you first access this page depend on how your appliance is currently connected to StorageGRID networks. Error messages might appear that will be resolved in later steps.

Home

i The installation is ready to be started. Review the settings below, and then click Start Installation.

This Node

Node type

Storage ▾

Node name

MM-2-108-SGA-lab25

Cancel

Save

Primary Admin Node connection

Enable Admin Node discovery

Primary Admin Node IP

172.16.1.178

Connection state

Connection to 172.16.1.178 ready

Cancel

Save

Installation

Current state

Ready to start installation of MM-2-108-SGA-lab25 into grid with Admin Node 172.16.1.178 running StorageGRID 11.2.0, using StorageGRID software downloaded from the Admin Node.

Start Installation

3. If the E5600SG controller could not acquire an IP address using DHCP:

a. Connect the service laptop to management port 2 on the E5600SG controller, using an Ethernet cable.



b. Open a web browser on the service laptop.

c. Enter this URL for the StorageGRID Appliance Installer:

https://169.254.0.1:8443

The StorageGRID Appliance Installer Home page appears. The information and messages shown when you first access this page depend on how your appliance is currently connected.



If you cannot access the Home page over a link-local connection, configure the service laptop IP address as 169.254.0.2, and try again.

4. Review any messages displayed on the Home page and configure the link configuration and the IP configuration, as required.

Related information

[Web browser requirements](#)

Verifying and upgrading the StorageGRID Appliance Installer version

The StorageGRID Appliance Installer version on the appliance must match the software version installed on your StorageGRID system to ensure that all StorageGRID features are supported.

What you'll need

You have accessed the StorageGRID Appliance Installer.

StorageGRID appliances come from the factory preinstalled with the StorageGRID Appliance Installer. If you are adding an appliance to a recently upgraded StorageGRID system, you might need to manually upgrade the StorageGRID Appliance Installer before installing the appliance as a new node.

The StorageGRID Appliance Installer automatically upgrades when you upgrade to a new StorageGRID version. You do not need to upgrade the StorageGRID Appliance Installer on installed appliance nodes. This procedure is only required when you are installing an appliance that contains an earlier version of the StorageGRID Appliance Installer.

Steps

1. From the StorageGRID Appliance Installer, select **Advanced > Upgrade Firmware**.
2. Compare the Current Firmware version to the software version installed on your StorageGRID system (from the Grid Manager select **Help > About**).

The second digit in the two versions should match. For example, if your StorageGRID system is running version 11.5.x.y, the StorageGRID Appliance Installer version should be 3.5.z.

3. If the appliance has a down-level version of the StorageGRID Appliance Installer, go to the NetApp Downloads page for StorageGRID.

[NetApp Downloads: StorageGRID](#)

Sign in with the username and password for your NetApp account.

4. Download the appropriate version of the **Support file for StorageGRID Appliances** and the corresponding checksum file.

The Support file for StorageGRID Appliances file is a .zip archive that contains the current and previous

firmware versions for all StorageGRID appliance models, in subdirectories for each controller type.

After downloading the Support file for StorageGRID Appliances file, extract the .zip archive and see the README file for important information about installing the StorageGRID Appliance Installer.

5. Follow the instructions on the Upgrade Firmware page of the StorageGRID Appliance Installer to perform these steps:
 - a. Upload the appropriate support file (firmware image) for your controller type and the checksum file.
 - b. Upgrade the inactive partition.
 - c. Reboot and swap partitions.
 - d. Upgrade the second partition.

Related information

[Accessing the StorageGRID Appliance Installer](#)

Configuring network links (SG5600)

You can configure network links for the ports used to connect the appliance to the Grid Network, the Client Network, and the Admin Network. You can set the link speed as well as the port and network bond modes.

What you'll need

If you plan to use Aggregate port bond mode, LACP network bond mode, or VLAN tagging:

- You have connected the 10-GbE ports on the appliance to switches that can support VLAN and LACP.
- If multiple switches are participating in the LACP bond, the switches support multi-chassis link aggregation groups (MLAG), or equivalent.
- You understand how to configure the switches to use VLAN, LACP, and MLAG or equivalent.
- You know the unique VLAN tag to use for each network. This VLAN tag will be added to each network packet to ensure that network traffic is routed to the correct network.

About this task

This figure shows how the four 10-GbE ports are bonded in fixed port bond mode (default configuration).

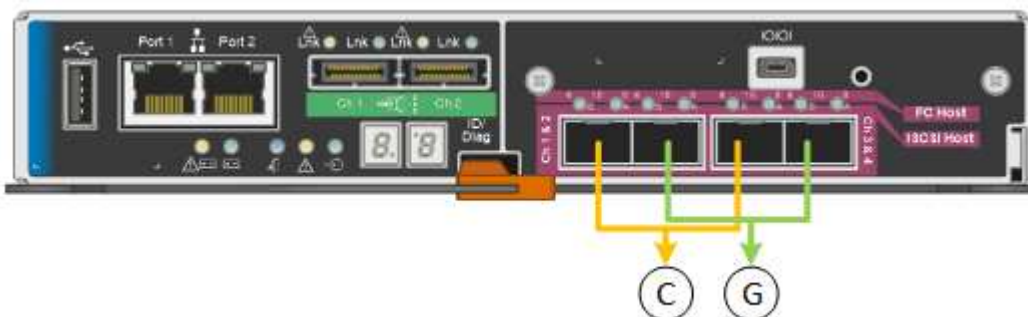

	Which ports are bonded
C	Ports 1 and 3 are bonded together for the Client Network, if this network is used.

	Which ports are bonded
G	Ports 2 and 4 are bonded together for the Grid Network.

This figure shows how the four 10-GbE ports are bonded in aggregate port bond mode.

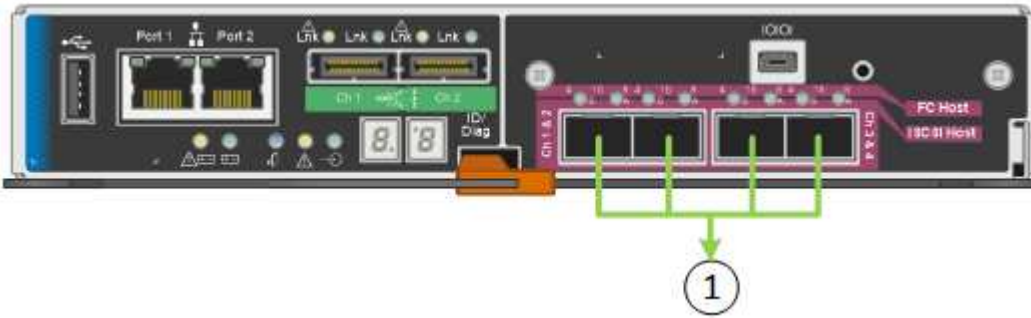

	Which ports are bonded
1	All four ports are grouped in a single LACP bond, allowing all ports to be used for Grid Network and Client Network traffic.

The table summarizes the options for configuring the four 10-GbE ports. You only need to configure the settings on the Link Configuration page if you want to use a non-default setting.

• **Fixed (default) port bond mode**

Network bond mode	Client Network disabled (default)	Client Network enabled
Active-Backup (default)	<ul style="list-style-type: none"> Ports 2 and 4 use an active-backup bond for the Grid Network. Ports 1 and 3 are not used. A VLAN tag is optional. 	<ul style="list-style-type: none"> Ports 2 and 4 use an active-backup bond for the Grid Network. Ports 1 and 3 use an active-backup bond for the Client Network. VLAN tags can be specified for both networks for the convenience of the network administrator.
LACP (802.3ad)	<ul style="list-style-type: none"> Ports 2 and 4 use an LACP bond for the Grid Network. Ports 1 and 3 are not used. A VLAN tag is optional. 	<ul style="list-style-type: none"> Ports 2 and 4 use an LACP bond for the Grid Network. Ports 1 and 3 use an LACP bond for the Client Network. VLAN tags can be specified for both networks for the convenience of the network administrator.

• **Aggregate port bond mode**

Network bond mode	Client Network disabled (default)	Client Network enabled
LACP (802.3ad) only	<ul style="list-style-type: none"> Ports 1-4 use a single LACP bond for the Grid Network. A single VLAN tag identifies Grid Network packets. 	<ul style="list-style-type: none"> Ports 1-4 use a single LACP bond for the Grid Network and the Client Network. Two VLAN tags allow Grid Network packets to be segregated from Client Network packets.

See “10-GbE port connections for the E5600SG controller” for more information about port bond and network bond modes.

This figure shows how the two 1-GbE management ports on the E5600SG controller are bonded in Active-Backup network bond mode for the Admin Network.



Steps

1. From the menu bar of the StorageGRID Appliance Installer, click **Configure Networking > Link Configuration**.

The Network Link Configuration page displays a diagram of your appliance with the network and management ports numbered.

Network Link Configuration

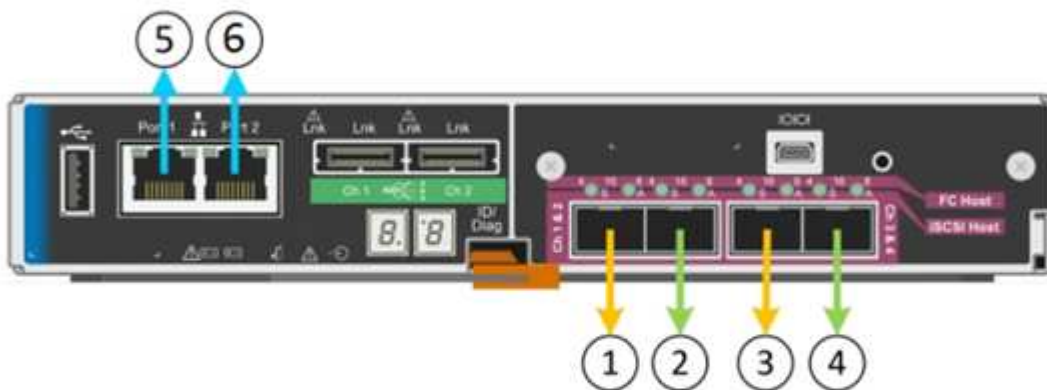

⚠ You might lose your connection if you make changes to the network or link you are connected through. If you are not reconnected within 1 minute, re-enter the URL using one of the other IP addresses assigned to the appliance.

The Link Status table lists the link state (up/down) and speed (1/10/25/40/100 Gbps) of the numbered ports.

Link Status

Link	State	Speed (Gbps)
1	Down	N/A
2	Up	10
3	Up	10
4	Down	N/A
5	Up	1
6	Up	1

The first time you access this page:

- **Link Speed** is set to **10GbE**. This is the only link speed available for the E5600SG controller.
- **Port bond mode** is set to **Fixed**.
- **Network bond mode** for the Grid Network is set to **Active-Backup**.
- The **Admin Network** is enabled, and the network bond mode is set to **Independent**.
- The **Client Network** is disabled.

Link Settings

Link speed

Port bond mode Fixed Aggregate

Choose Fixed port bond mode if you want to use ports 2 and 4 for the Grid Network and ports 1 and 3 for the Client Network (if enabled). Choose Aggregate port bond mode if you want all connected ports to share a single LACP bond for both the Grid and Client Networks.

Grid Network

Enable network

Network bond mode Active-Backup LACP (802.3ad)

Enable VLAN (802.1q) tagging

MAC Addresses 50:6b:4b:42:d7:00 50:6b:4b:42:d7:01 50:6b:4b:42:d7:24 50:6b:4b:42:d7:25

If you are using DHCP, it is recommended that you configure a permanent DHCP reservation. Use all of these MAC addresses in the reservation to assign one IP address to this network interface.

Admin Network

Enable network

Network bond mode Independent Active-Backup

Connect the Admin Network to port 5. Leave port 6 unconnected. If necessary, you can make a temporary direct Ethernet connection to port 6 and use link-local IP address 169.254.0.1 for access.

MAC Addresses d8:c4:97:2a:e4:95

If you are using DHCP, it is recommended that you configure a permanent DHCP reservation. Use all of these MAC addresses in the reservation to assign one IP address to this network interface.

Client Network

Enable network

Enabling the Client Network causes the default gateway for this node to move to the Client Network. Before enabling the Client Network, ensure that you've added all necessary subnets to the Grid Network Subnet List. Otherwise, the connection to the node might be lost.

2. Enable or disable the StorageGRID networks you plan to use.

The Grid Network is required. You cannot disable this network.

- a. If the appliance is not connected to the Admin Network, unselect the **Enable network** check box for the Admin Network.

Admin Network

Enable network



- b. If the appliance is connected to the Client Network, select the **Enable network** check box for the Client Network.

The Client Network settings for the 10-GbE ports are now shown.

3. Refer to the table, and configure the port bond mode and the network bond mode.

The example shows:

- **Aggregate** and **LACP** selected for the Grid and the Client networks. You must specify a unique VLAN tag for each network. You can select values between 0 and 4095.
- **Active-Backup** selected for the Admin Network.

Link Settings

Link speed

Port bond mode Fixed Aggregate

Choose Fixed port bond mode if you want to use ports 2 and 4 for the Grid Network and ports 1 and 3 for the Client Network (if enabled). Choose Aggregate port bond mode if you want all connected ports to share a single LACP bond for both the Grid and Client Networks.

Grid Network

Enable network

Network bond mode Active-Backup LACP (802.3ad)

If the port bond mode is Aggregate, all bonds must be in LACP (802.3ad) mode.

Enable VLAN (802.1q) tagging

VLAN (802.1q) tag

Admin Network

Enable network

Network bond mode Independent Active-Backup

Connect the Admin Network to ports 5 and 6. If necessary, you can make a temporary direct Ethernet connection by disconnecting ports 5 and 6, then connecting to port 6 and using link-local IP address 169.254.0.1 for access.

Client Network

Enable network

Network bond mode Active-Backup LACP (802.3ad)

If the port bond mode is Aggregate, all bonds must be in LACP (802.3ad) mode.

Enable VLAN (802.1q) tagging

VLAN (802.1q) tag

4. When you are satisfied with your selections, click **Save**.



You might lose your connection if you made changes to the network or link you are connected through. If you are not reconnected within 1 minute, re-enter the URL for the StorageGRID Appliance Installer using one of the other IP addresses assigned to the appliance:

`https://E5600SG_Controller_IP:8443`

Related information

[Port bond modes for the E5600SG controller ports](#)

Setting the IP configuration

You use the StorageGRID Appliance Installer to configure the IP addresses and routing

information used for the appliance Storage Node on the StorageGRID Grid, Admin, and Client Networks.

About this task

You must either assign a static IP for the appliance on each connected network or assign a permanent lease for the address on the DHCP server.

If you want to change the link configuration, see the instructions for changing the link configuration of the E5600SG controller.

Steps

1. In the StorageGRID Appliance Installer, select **Configure Networking > IP Configuration**.

The IP Configuration page appears.

2. To configure the Grid Network, select either **Static** or **DHCP** in the **Grid Network** section of the page.

Grid Network

The Grid Network is used for all internal StorageGRID traffic. The Grid Network provides connectivity between all nodes in the grid, across all sites and subnets. All hosts on the Grid Network must be able to talk to all other hosts. The Grid Network can consist of multiple subnets. Networks containing critical grid services, such as NTP, can also be added as Grid subnets.

IP Assignment Static DHCP



IPv4 Address (CIDR)

Gateway

 All required Grid Network subnets must also be defined in the Grid Network Subnet List on the Primary Admin Node before starting installation.

Subnets (CIDR) 



MTU 

3. If you selected **Static**, follow these steps to configure the Grid Network:

- Enter the static IPv4 address, using CIDR notation.
- Enter the gateway.

If your network does not have a gateway, re-enter the same static IPv4 address.

- If you want to use jumbo frames, change the MTU field to a value suitable for jumbo frames, such as 9000. Otherwise, keep the default value of 1500.



The MTU value of the network must match the value configured on the switch port the node is connected to. Otherwise, network performance issues or packet loss might occur.



For the best network performance, all nodes should be configured with similar MTU values on their Grid Network interfaces. The **Grid Network MTU mismatch** alert is triggered if there is a significant difference in MTU settings for the Grid Network on individual nodes. The MTU values do not have to be the same for all network types.

d. Click **Save**.

When you change the IP address, the gateway and list of subnets might also change.

If you lose your connection to the StorageGRID Appliance Installer, re-enter the URL using the new static IP address you just assigned. For example,

`https://services_appliance_IP:8443`

e. Confirm that the list of Grid Network subnets is correct.

If you have grid subnets, the Grid Network gateway is required. All grid subnets specified must be reachable through this gateway. These Grid Network subnets must also be defined in the Grid Network Subnet List on the primary Admin Node when you start StorageGRID installation.



The default route is not listed. If the Client Network is not enabled, the default route will use the Grid Network gateway.

- To add a subnet, click the insert icon **+** to the right of the last entry.
- To remove an unused subnet, click the delete icon **x**.

f. Click **Save**.

4. If you selected **DHCP**, follow these steps to configure the Grid Network:

a. After you select the **DHCP** radio button, click **Save**.

The **IPv4 Address**, **Gateway**, and **Subnets** fields are automatically populated. If the DHCP server is set up to assign an MTU value, the **MTU** field is populated with that value, and the field becomes read-only.

Your web browser is automatically redirected to the new IP address for the StorageGRID Appliance Installer.

b. Confirm that the list of Grid Network subnets is correct.

If you have grid subnets, the Grid Network gateway is required. All grid subnets specified must be reachable through this gateway. These Grid Network subnets must also be defined in the Grid Network Subnet List on the primary Admin Node when you start StorageGRID installation.



The default route is not listed. If the Client Network is not enabled, the default route will use the Grid Network gateway.

- To add a subnet, click the insert icon **+** to the right of the last entry.
- To remove an unused subnet, click the delete icon **x**.

c. If you want to use jumbo frames, change the MTU field to a value suitable for jumbo frames, such as 9000. Otherwise, keep the default value of 1500.



The MTU value of the network must match the value configured on the switch port the node is connected to. Otherwise, network performance issues or packet loss might occur.



For the best network performance, all nodes should be configured with similar MTU values on their Grid Network interfaces. The **Grid Network MTU mismatch** alert is triggered if there is a significant difference in MTU settings for the Grid Network on individual nodes. The MTU values do not have to be the same for all network types.

d. Click **Save**.

5. To configure the Admin Network, select either **Static** or **DHCP** in the Admin Network section of the page.



To configure the Admin Network, you must enable the Admin Network on the Link Configuration page.

Admin Network

The Admin Network is a closed network used for system administration and maintenance. The Admin Network is typically a private network and does not need to be routable between sites.

IP Assignment Static DHCP

IPv4 Address (CIDR)

Gateway

Subnets (CIDR) **+**

MTU

6. If you selected **Static**, follow these steps to configure the Admin Network:

a. Enter the static IPv4 address, using CIDR notation, for Management Port 1 on the appliance.

Management Port 1 is the left of the two 1-GbE RJ45 ports on the right end of the appliance.

b. Enter the gateway.

If your network does not have a gateway, re-enter the same static IPv4 address.

c. If you want to use jumbo frames, change the MTU field to a value suitable for jumbo frames, such as

9000. Otherwise, keep the default value of 1500.



The MTU value of the network must match the value configured on the switch port the node is connected to. Otherwise, network performance issues or packet loss might occur.

d. Click **Save**.

When you change the IP address, the gateway and list of subnets might also change.

If you lose your connection to the StorageGRID Appliance Installer, re-enter the URL using the new static IP address you just assigned. For example,

`https://services_appliance:8443`

e. Confirm that the list of Admin Network subnets is correct.

You must verify that all subnets can be reached using the gateway you provided.



The default route cannot be made to use the Admin Network gateway.

- To add a subnet, click the insert icon **+** to the right of the last entry.
- To remove an unused subnet, click the delete icon **x**.

f. Click **Save**.

7. If you selected **DHCP**, follow these steps to configure the Admin Network:

a. After you select the **DHCP** radio button, click **Save**.

The **IPv4 Address**, **Gateway**, and **Subnets** fields are automatically populated. If the DHCP server is set up to assign an MTU value, the **MTU** field is populated with that value, and the field becomes read-only.

Your web browser is automatically redirected to the new IP address for the StorageGRID Appliance Installer.

b. Confirm that the list of Admin Network subnets is correct.

You must verify that all subnets can be reached using the gateway you provided.



The default route cannot be made to use the Admin Network gateway.

- To add a subnet, click the insert icon **+** to the right of the last entry.
- To remove an unused subnet, click the delete icon **x**.

c. If you want to use jumbo frames, change the MTU field to a value suitable for jumbo frames, such as 9000. Otherwise, keep the default value of 1500.



The MTU value of the network must match the value configured on the switch port the node is connected to. Otherwise, network performance issues or packet loss might occur.

d. Click **Save**.

8. To configure the Client Network, select either **Static** or **DHCP** in the **Client Network** section of the page.



To configure the Client Network, you must enable the Client Network on the Link Configuration page.

Client Network

The Client Network is an open network used to provide access to client applications, including S3 and Swift. The Client Network enables grid nodes to communicate with any subnet reachable through the Client Network gateway. The Client Network does not become operational until you complete the StorageGRID configuration steps.

IP Assignment Static DHCP

IPv4 Address (CIDR)

Gateway

MTU

9. If you selected **Static**, follow these steps to configure the Client Network:

- Enter the static IPv4 address, using CIDR notation.
- Click **Save**.
- Confirm that the IP address for the Client Network gateway is correct.



If the Client Network is enabled, the default route is displayed. The default route uses the Client Network gateway and cannot be moved to another interface while the Client Network is enabled.

- If you want to use jumbo frames, change the MTU field to a value suitable for jumbo frames, such as 9000. Otherwise, keep the default value of 1500.



The MTU value of the network must match the value configured on the switch port the node is connected to. Otherwise, network performance issues or packet loss might occur.

- Click **Save**.

10. If you selected **DHCP**, follow these steps to configure the Client Network:

- After you select the **DHCP** radio button, click **Save**.

The **IPv4 Address** and **Gateway** fields are automatically populated. If the DHCP server is set up to assign an MTU value, the **MTU** field is populated with that value, and the field becomes read-only.

Your web browser is automatically redirected to the new IP address for the StorageGRID Appliance Installer.

- b. Confirm that the gateway is correct.



If the Client Network is enabled, the default route is displayed. The default route uses the Client Network gateway and cannot be moved to another interface while the Client Network is enabled.

- c. If you want to use jumbo frames, change the MTU field to a value suitable for jumbo frames, such as 9000. Otherwise, keep the default value of 1500.



The MTU value of the network must match the value configured on the switch port the node is connected to. Otherwise, network performance issues or packet loss might occur.

Related information

[Changing the link configuration of the E5600SG controller](#)

Verifying network connections

You should confirm you can access the StorageGRID networks you are using from the appliance. To validate routing through network gateways, you should test connectivity between the StorageGRID Appliance Installer and IP addresses on different subnets. You can also verify the MTU setting.

Steps

1. From the menu bar of the StorageGRID Appliance Installer, click **Configure Networking > Ping and MTU Test**.

The Ping and MTU Test page appears.

Ping and MTU Test

Use a ping request to check the appliance's connectivity to a remote host. Select the network you want to check connectivity through, and enter the IP address of the host you want to reach. To verify the MTU setting for the entire path through the network to the destination, select Test MTU.

Ping and MTU Test

Network: Grid

Destination IPv4 Address or FQDN: [Empty text box]

Test MTU:

Test Connectivity

2. From the **Network** drop-down box, select the network you want to test: Grid, Admin, or Client.

3. Enter the IPv4 address or fully qualified domain name (FQDN) for a host on that network.

For example, you might want to ping the gateway on the network or the primary Admin Node.

4. Optionally, select the **Test MTU** check box to verify the MTU setting for the entire path through the network to the destination.

For example, you can test the path between the appliance node and a node at a different site.

5. Click **Test Connectivity**.

If the network connection is valid, the "Ping test passed" message appears, with the ping command output listed.

Ping and MTU Test

Use a ping request to check the appliance's connectivity to a remote host. Select the network you want to check connectivity through, and enter the IP address of the host you want to reach. To verify the MTU setting for the entire path through the network to the destination, select Test MTU.

Ping and MTU Test

Network	<input type="text" value="Grid"/>
Destination IPv4 Address or FQDN	<input type="text" value="10.96.104.223"/>
Test MTU	<input checked="" type="checkbox"/>
<input type="button" value="Test Connectivity"/>	

Ping test passed

Ping command output

```
PING 10.96.104.223 (10.96.104.223) 1472(1500) bytes of data.  
1480 bytes from 10.96.104.223: icmp_seq=1 ttl=64 time=0.318 ms  
  
--- 10.96.104.223 ping statistics ---  
1 packets transmitted, 1 received, 0% packet loss, time 0ms  
rtt min/avg/max/mdev = 0.318/0.318/0.318/0.000 ms  
  
Found MTU 1500 for 10.96.104.223 via br0
```

Related information

[Configuring network links \(SG5600\)](#)

[Changing the MTU setting](#)

Verifying port-level network connections

To ensure that access between the StorageGRID Appliance Installer and other nodes is

not obstructed by firewalls, confirm that the StorageGRID Appliance Installer can connect to a specific TCP port or set of ports at the specified IP address or range of addresses.

About this task

Using the list of ports provided in the StorageGRID Appliance Installer, you can test the connectivity between the appliance and the other nodes in your Grid Network.

Additionally, you can test connectivity on the Admin and Client Networks and on UDP ports, such as those used for external NFS or DNS servers. For a list of these ports, see the port reference in the StorageGRID networking guidelines.



The Grid Network ports listed in the port connectivity table are valid only for StorageGRID version 11.5.0. To verify which ports are correct for each node type, you should always consult the networking guidelines for your version of StorageGRID.

Steps

1. From the StorageGRID Appliance Installer, click **Configure Networking > Port Connectivity Test (nmap)**.

The Port Connectivity Test page appears.

The port connectivity table lists node types that require TCP connectivity on the Grid Network. For each node type, the table lists the Grid Network ports that should be accessible to your appliance.

The following node types require TCP connectivity on the Grid Network.

Node Type	Grid Network Ports
Admin Node	22,80,443,1504,1505,1506,1508,7443,9999
Storage Node without ADC	22,1139,1502,1506,1511,7001,9042,9999,18002,18017,18019,18082,18083,18200
Storage Node with ADC	22,1139,1501,1502,1506,1511,7001,9042,9999,18000,18001,18002,18003,18017,18019,18082,18083,18200,19000
API Gateway	22,1506,1507,9999
Archive Node	22,1506,1509,9999,11139

You can test the connectivity between the appliance ports listed in the table and the other nodes in your Grid Network.

2. From the **Network** drop-down, select the network you want to test: **Grid**, **Admin**, or **Client**.
3. Specify a range of IPv4 addresses for the hosts on that network.

For example, you might want to probe the gateway on the network or the primary Admin Node.

Specify a range using a hyphen, as shown in the example.

4. Enter a TCP port number, a list of ports separated by commas, or a range of ports.

The following node types require TCP connectivity on the Grid Network.

Node Type	Grid Network Ports
Admin Node	22,80,443,1504,1505,1506,1508,7443,9999
Storage Node without ADC	22,1139,1502,1506,1511,7001,9042,9999,18002,18017,18019,18082,18083,18200
Storage Node with ADC	22,1139,1501,1502,1506,1511,7001,9042,9999,18000,18001,18002,18003,18017,18019,18082,18083,18200,19000
API Gateway	22,1506,1507,9999
Archive Node	22,1506,1509,9999,11139

Port Connectivity Test

Network

IPv4 Address Ranges

Port Ranges

Protocol TCP UDP

5. Click **Test Connectivity**.

- If the selected port-level network connections are valid, the “Port connectivity test passed” message appears in a green banner. The nmap command output is listed below the banner.

Port connectivity test passed

Nmap command output. Note: Unreachable hosts will not appear in the output.

```
# Nmap 7.70 scan initiated Fri Nov 13 18:32:03 2020 as: /usr/bin/nmap -n -oN - -e br0 -p 22,2022 10.224.6.160-161
Nmap scan report for 10.224.6.160
Host is up (0.00072s latency).

PORT      STATE SERVICE
22/tcp    open  ssh
2022/tcp  open  down

Nmap scan report for 10.224.6.161
Host is up (0.00060s latency).

PORT      STATE SERVICE
22/tcp    open  ssh
2022/tcp  open  down

# Nmap done at Fri Nov 13 18:32:04 2020 -- 2 IP addresses (2 hosts up) scanned in 0.55 seconds
```

- If a port-level network connection is made to the remote host, but the host is not listening on one or more of the selected ports, the “Port connectivity test failed” message appears in a yellow banner. The nmap command output is listed below the banner.

Any remote port the host is not listening to has a state of “closed.” For example, you might see this yellow banner when the node you are trying to connect to is in a pre-installed state and the StorageGRID NMS service is not yet running on that node.

 Port connectivity test failed
Connection not established. Services might not be listening on target ports.

Nmap command output. Note: Unreachable hosts will not appear in the output.

```
# Nmap 7.70 scan initiated Sat May 16 17:07:02 2020 as: /usr/bin/nmap -n -oN - -e br0 -p 22,80,443,1504,1505,1506,1508,7443,9999
Nmap scan report for 172.16.4.71
Host is up (0.00020s latency).

PORT      STATE SERVICE
22/tcp    open  ssh
80/tcp    open  http
443/tcp   open  https
1504/tcp   closed evb-elm
1505/tcp   open  funkproxy
1506/tcp   open  utcd
1508/tcp   open  diagmond
7443/tcp   open  oracleas-https
9999/tcp   open  abyss
MAC Address: 00:50:56:87:39:AE (VMware)

# Nmap done at Sat May 16 17:07:03 2020 -- 1 IP address (1 host up) scanned in 0.59 seconds
```

- If a port-level network connection cannot be made for one or more selected ports, the “Port connectivity test failed” message appears in a red banner. The nmap command output is listed below the banner.

The red banner indicates that a TCP connection attempt to a port on the remote host was made, but nothing was returned to the sender. When no response is returned, the port has a state of “filtered” and is likely blocked by a firewall.



Ports with “closed” are also listed.

 Port connectivity test failed
Connection failed to one or more ports.

Nmap command output. Note: Unreachable hosts will not appear in the output.

```
# Nmap 7.70 scan initiated Sat May 16 17:11:01 2020 as: /usr/bin/nmap -n -oN - -e br0 -p 22,79,80,443,1504,1505,1506,1508,7443,9999 172.16.4.71
Nmap scan report for 172.16.4.71
Host is up (0.00029s latency).

PORT      STATE SERVICE
22/tcp    open  ssh
79/tcp    filtered finger
80/tcp    open  http
443/tcp   open  https
1504/tcp   closed evb-elm
1505/tcp   open  funkproxy
1506/tcp   open  utcd
1508/tcp   open  diagmond
7443/tcp   open  oracleas-https
9999/tcp   open  abyss
MAC Address: 00:50:56:87:39:AE (VMware)

# Nmap done at Sat May 16 17:11:02 2020 -- 1 IP address (1 host up) scanned in 1.60 seconds
```

Related information

[Network guidelines](#)

Configuring SANtricity Storage Manager

You can use SANtricity Storage Manager to monitor the status of the storage disks and hardware components in your StorageGRID appliance. To access this software, you must

know the IP address of management port 1 on the E2700 controller (the storage controller in the appliance).

Steps

- [Setting the IP address for the E2700 controller](#)
- [Adding the appliance to SANtricity Storage Manager](#)
- [Setting up SANtricity Storage Manager](#)

Setting the IP address for the E2700 controller

Management port 1 on the E2700 controller connects the appliance to the management network for SANtricity Storage Manager. You must set a static IP address for the E2700 controller to ensure that you do not lose your management connection to the hardware and the controller firmware in the StorageGRID appliance.

What you'll need

You are using a supported web browser.

About this task

DHCP-assigned addresses could change at any time. Assign a static IP address to the controller to ensure consistent accessibility.

Steps

1. From the client, enter the URL for the StorageGRID Appliance Installer:
`https://E5600SG_Controller_IP:8443`

For `E5600SG_Controller_IP`, use the IP address for the appliance on any StorageGRID network.

The StorageGRID Appliance Installer Home page appears.

2. Select **Hardware Configuration > Storage Controller Network Configuration**.

The Storage Controller Network Configuration page appears.

3. Depending on your network configuration, select **Enabled** for IPv4, IPv6, or both.
4. Make a note of the IPv4 address that is automatically displayed.

DHCP is the default method for assigning an IP address to this port.



It might take a few minutes for the DHCP values to appear.

IPv4 Address Assignment

Static DHCP

IPv4 Address (CIDR)

10.224.5.166/21

Default Gateway

10.224.0.1

5. Optionally, set a static IP address for the E2700 controller management port.



You should either assign a static IP for the management port or assign a permanent lease for the address on the DHCP server.

- a. Select **Static**.
- b. Enter the IPv4 address, using CIDR notation.
- c. Enter the default gateway.

IPv4 Address Assignment Static DHCP

IPv4 Address (CIDR)	10.224.2.200/21
Default Gateway	10.224.0.1

- d. Click **Save**.

It might take a few minutes for your changes to be applied.

When you connect to SANtricity Storage Manager, you will use the new static IP address as the URL:
https://E2700_Controller_IP

Related information

[NetApp Documentation: SANtricity Storage Manager](#)

Adding the appliance to SANtricity Storage Manager

You connect the E2700 controller in the appliance to SANtricity Storage Manager and then add the appliance as a storage array.

What you'll need

You are using a supported web browser.

About this task

For detailed instructions, see the SANtricity Storage Manager documentation.

Steps

1. Open a web browser, and enter the IP address as the URL for SANtricity Storage Manager:
https://E2700_Controller_IP

The login page for SANtricity Storage Manager appears.

2. On the **Select Addition Method** page, select **Manual**, and click **OK**.
3. Select **Edit > Add Storage Array**.

The Add New Storage Array - Manual page appears.

4. In the **Out-of-band management** box, enter one of the following values:

- **Using DHCP:** The IP address assigned by the DHCP server to management port 1 on the E2700 controller
- **Not using DHCP:** 192.168.128.101



Only one of the appliance's controllers is connected to SANtricity Storage Manager, so you only need to enter one IP address.

5. Click **Add**.

Related information

[NetApp Documentation: SANtricity Storage Manager](#)

Setting up SANtricity Storage Manager

After accessing SANtricity Storage Manager, you can use it to configure hardware settings. Typically, you configure these settings before deploying the appliance as a Storage Node in a StorageGRID system.

Steps

- [Configuring AutoSupport](#)
- [Verifying receipt of AutoSupport](#)
- [Configuring email and SNMP trap alert notifications](#)
- [Setting passwords for SANtricity Storage Manager](#)

Configuring AutoSupport

The AutoSupport tool collects data in a customer support bundle from the appliance and automatically sends the data to technical support. Configuring AutoSupport assists technical support with remote troubleshooting and problem analysis.

What you'll need

- The AutoSupport feature must be enabled and activated on the appliance.

The AutoSupport feature is activated and deactivated globally on a storage management station.

- The Storage Manager Event Monitor must be running on at least one machine with access to the appliance and, preferably, on no more than one machine.

About this task

All of the data is compressed into a single compressed archive file format (.7z) at the location you specify.

AutoSupport provides the following types of messages:

Message types	Description
Event messages	<ul style="list-style-type: none"> • Sent when a support event on the managed appliance occurs • Include system configuration and diagnostic information
Daily messages	<ul style="list-style-type: none"> • Sent once every day during a user configurable time interval in the local time of the appliance • Include the current system event logs and performance data
Weekly messages	<ul style="list-style-type: none"> • Sent once every week during a user configurable time interval in the local time of the appliance • Include configuration and system state information

Steps

1. From the Enterprise Management Window in SANtricity Storage Manager, select the **Devices** tab, and then select **Discovered Storage Arrays**.
2. Select **Tools > AutoSupport > Configuration**.
3. Use SANtricity Storage Manager online help, if needed, to complete the task.

Related information

Verifying receipt of AutoSupport

You should verify that technical support is receiving your AutoSupport messages. You can find the status of AutoSupport for your systems on the Active IQ portal. Verifying receipt of these messages ensures that technical support has your information if you need assistance.

About this task

AutoSupport can show one of the following statuses:

- **ON**

An ON status indicates that technical support is currently receiving AutoSupport messages from the system.

- **OFF**

An OFF status suggests that you might have disabled AutoSupport because technical support has not received a Weekly Log from the system in the last 15 calendar days or there might have been a change in your environment or configuration (as an example).

- **DECLINE**

A DECLINE status means that you have notified technical support that you will not enable AutoSupport.

After technical support receives a Weekly Log from the system, the AutoSupport status changes to ON.

Steps

1. Go to the NetApp Support Site at mysupport.netapp.com, and sign in to the Active IQ portal.
2. If the AutoSupport status is OFF, and you believe that is incorrect, complete the following:
 - a. Check your system configuration to ensure that you have turned AutoSupport on.
 - b. Check your network environment and configuration to ensure that the system can send messages to technical support.

Configuring email and SNMP trap alert notifications

SANtricity Storage Manager can notify you when the status of the appliance or one of its components changes. This is called an alert notification. You can receive alert notifications by two different methods: email and SNMP traps. You must configure the alert notifications you want to receive.

Steps

1. From the Enterprise Management Window in SANtricity Storage Manager, select the **Devices** tab, and then select a node.
2. Select **Edit > Configure Alerts**.
3. Select the **Email** tab to configure email alert notifications.
4. Select the **SNMP** tab to configure SNMP trap alert notifications.

5. Use SANtricity Storage Manager online help, if needed, to complete the task.

Setting passwords for SANtricity Storage Manager

You can set the passwords used for the appliance in SANtricity Storage Manager. Setting passwords maintains system security.

Steps

1. From the Enterprise Management Window in SANtricity Storage Manager, double-click the controller.
2. From the Array Management Window, select the **Storage Array** menu, and select **Security > Set Password**.
3. Configure the passwords.
4. Use SANtricity Storage Manager online help, if needed, to complete the task.

Optional: Enabling node encryption

If you enable node encryption, the disks in your appliance can be protected by secure key management server (KMS) encryption against physical loss or removal from the site. You must select and enable node encryption during appliance installation and cannot unselect node encryption once the KMS encryption process starts.

What you'll need

Review the information about KMS in the instructions for administering StorageGRID.

About this task

An appliance that has node encryption enabled connects to the external key management server (KMS) that is configured for the StorageGRID site. Each KMS (or KMS cluster) manages the encryption keys for all appliance nodes at the site. These keys encrypt and decrypt the data on each disk in an appliance that has node encryption enabled.

A KMS can be set up in Grid Manager before or after the appliance is installed in StorageGRID. See the information about KMS and appliance configuration in the instructions for administering StorageGRID for additional details.

- If a KMS is set up before installing the appliance, KMS-controlled encryption begins when you enable node encryption on the appliance and add it to a StorageGRID site where KMS is configured.
- If a KMS is not set up before you install the appliance, KMS-controlled encryption is performed on each appliance that has node encryption enabled as soon as a KMS is configured and available for the site that contains the appliance node.



Any data that exists before an appliance that has node encryption enabled connects to the configured KMS is encrypted with a temporary key that is not secure. The appliance is not protected from removal or theft until the key is set to a value provided by the KMS.

Without the KMS key needed to decrypt the disk, data on the appliance cannot be retrieved and is effectively lost. This is the case whenever the decryption key cannot be retrieved from the KMS. The key becomes inaccessible if a customer clears the KMS configuration, a KMS key expires, connection to the KMS is lost, or the appliance is removed from the StorageGRID system where its KMS keys are installed.

Steps

1. Open a browser, and enter one of the IP addresses for the appliance's compute controller.

https://Controller_IP:8443

Controller_IP is the IP address of the compute controller (not the storage controller) on any of the three StorageGRID networks.

The StorageGRID Appliance Installer Home page appears.



After the appliance has been encrypted with a KMS key, the appliance disks cannot be decrypted without using the same KMS key.

2. Select **Configure Hardware > Node Encryption**.

NetApp® StorageGRID® Appliance Installer Help ▾

Home Configure Networking ▾ Configure Hardware ▾ Monitor Installation Advanced ▾

Node Encryption

Node encryption allows you to use an external key management server (KMS) to encrypt all StorageGRID data on this appliance. If node encryption is enabled for the appliance and a KMS is configured for the site, you cannot access any data on the appliance unless the appliance can communicate with the KMS.

Encryption Status

⚠ You can only enable node encryption for an appliance during installation. You cannot enable or disable the node encryption setting after the appliance is installed.

Enable node encryption

Save

Key Management Server Details

3. Select **Enable node encryption**.

You can unselect **Enable node encryption** without risk of data loss until you select **Save** and the appliance node accesses the KMS encryption keys in your StorageGRID system and begins disk encryption. You are not able to disable node encryption after the appliance is installed.



After you add an appliance that has node encryption enabled to a StorageGRID site that has a KMS, you cannot stop using KMS encryption for the node.

4. Select **Save**.
5. Deploy the appliance as a node in your StorageGRID system.

KMS-controlled encryption begins when the appliance accesses the KMS keys configured for your StorageGRID site. The installer displays progress messages during the KMS encryption process, which might take a few minutes depending on the number of disk volumes in the appliance.



Appliances are initially configured with a random non-KMS encryption key assigned to each disk volume. The disks are encrypted using this temporary encryption key, that is not secure, until the appliance that has node encryption enabled accesses the KMS keys configured for your StorageGRID site.

After you finish

You can view node-encryption status, KMS details, and the certificates in use when the appliance node is in

maintenance mode.

Related information

[Administer StorageGRID](#)

[Monitoring node encryption in maintenance mode](#)

Optional: Changing to RAID6 mode (SG5660 only)

If you have an SG5660 with 60 drives, you can change the volume configuration from its default and recommended setting, Dynamic Disk Pools (DDP), to RAID6. You can only change the mode before deploying the StorageGRID appliance Storage Node.

What you'll need

- You have an SG5660. The SG5612 does not support RAID6. If you have an SG5612, you must use DDP mode.



If any volumes have already been configured or if StorageGRID was previously installed, changing the RAID mode causes the volumes to be removed and replaced. Any data on those volumes will be lost.

About this task

Before deploying a StorageGRID appliance Storage Node, you can choose from two volume configuration options:

- **Dynamic Disk Pools (DDP)** — This is the default and recommended setting. DDP is an enhanced hardware data protection scheme that delivers better system performance, reduced rebuild times after drive failures, and ease of management.
- **RAID6** — This is a hardware protection scheme that uses parity stripes on each disk, and allows for two disk failures within the RAID set before any data is lost.



Using RAID6 is not recommended for most StorageGRID environments. Although RAID6 can increase storage efficiency to 88% (compared to 80% for DDP), DDP mode provides more efficient recovery from drive failures.

Steps

1. Using the service laptop, open a web browser and access the StorageGRID Appliance Installer:
`https://E5600SG_Controller_IP:8443`

Where *E5600SG_Controller_IP* is any of the IP addresses for the E5600SG controller.

2. From the menu bar, select **Advanced > RAID Mode**.
3. On the **Configure RAID Mode** page, select **RAID6** from the Mode drop-down list.
4. Click **Save**.

Optional: Remapping network ports for the appliance

You might need to remap the internal ports on the appliance Storage Node to different external ports. For example, you might need to remap ports because of a firewall issue.

What you'll need

- You have previously accessed the StorageGRID Appliance Installer.
- You have not configured and do not plan to configure load balancer endpoints.



If you remap any ports, you cannot use the same ports to configure load balancer endpoints. If you want to configure load balancer endpoints and have already remapped ports, follow the steps in the recovery and maintenance instructions for removing port remaps.

Steps

1. From the menu bar of the StorageGRID Appliance Installer, click **Configure Networking > Remap Ports**.

The Remap Port page appears.

2. From the **Network** drop-down box, select the network for the port you want to remap: Grid, Admin, or Client.
3. From the **Protocol** drop-down box, select the IP protocol: TCP or UDP.
4. From the **Remap Direction** drop-down box, select which traffic direction you want to remap for this port: Inbound, Outbound, or Bi-directional.
5. For **Original Port**, enter the number of the port you want to remap.
6. For **Mapped-To Port**, enter the number of the port you want to use instead.
7. Click **Add Rule**.

The new port mapping is added to the table, and the remapping takes effect immediately.

Remap Ports

If required, you can remap the internal ports on the appliance Storage Node to different external ports. For example, you might need to remap ports because of a firewall issue.

	Network	Protocol	Remap Direction	Original Port	Mapped-To Port
<input type="radio"/>	Grid	TCP	Bi-directional	1800	1801

8. To remove a port mapping, select the radio button for the rule you want to remove, and click **Remove Selected Rule**.

Related information

[Maintain & recover](#)

Deploying an appliance Storage Node

After installing and configuring the storage appliance, you can deploy it as a Storage Node in a StorageGRID system. When you deploy an appliance as a Storage Node, you

use the StorageGRID Appliance Installer included on the appliance.

What you'll need

- If you are cloning an appliance node, continue following the process in recovery and maintenance.

Maintain & recover

- The appliance has been installed in a rack or cabinet, connected to your networks, and powered on.
- Network links, IP addresses, and port remapping (if necessary) have been configured for the appliance using the StorageGRID Appliance Installer.
- You know one of the IP addresses assigned to the appliance's compute controller. You can use the IP address for any attached StorageGRID network.
- The primary Admin Node for the StorageGRID system has been deployed.
- All Grid Network subnets listed on the IP Configuration page of the StorageGRID Appliance Installer have been defined in the Grid Network Subnet List on the primary Admin Node.
- You have a service laptop with a supported web browser.

About this task

Each storage appliance functions as a single Storage Node. Any appliance can connect to the Grid Network, the Admin Network, and the Client Network

To deploy an appliance Storage Node in a StorageGRID system, you access the StorageGRID Appliance Installer and perform the following steps:

- You specify or confirm the IP address of the primary Admin Node and the name of the Storage Node.
- You start the deployment and wait as volumes are configured and the software is installed.
- When the installation pauses partway through the appliance installation tasks, you resume the installation by signing into the Grid Manager, approving all grid nodes, and completing the StorageGRID installation and deployment processes.



If you need to deploy multiple appliance nodes at one time, you can automate the installation process by using the `configure-sga.py` Appliance Installation script.

- If you are performing an expansion or recovery operation, follow the appropriate instructions:
 - To add an appliance Storage Node to an existing StorageGRID system, see the instructions for expanding a StorageGRID system.
 - To deploy an appliance Storage Node as part of a recovery operation, see instructions for recovery and maintenance.

Steps

1. Open a browser, and enter one of the IP addresses for the appliance's compute controller.

`https://Controller_IP:8443`

The StorageGRID Appliance Installer Home page appears.

Home

 The installation is ready to be started. Review the settings below, and then click Start Installation.

Primary Admin Node connection

Enable Admin Node discovery

Primary Admin Node IP

Connection state

Connection to 172.16.4.210 ready

Node name

Node name

Installation

Current state

Ready to start installation of NetApp-SGA into grid with Admin Node 172.16.4.210.

2. In the **Primary Admin Node** connection section, determine whether you need to specify the IP address for the primary Admin Node.

If you have previously installed other nodes in this data center, the StorageGRID Appliance Installer can discover this IP address automatically, assuming the primary Admin Node, or at least one other grid node with ADMIN_IP configured, is present on the same subnet.

3. If this IP address is not shown or you need to change it, specify the address:

Option	Description
Manual IP entry	<ol style="list-style-type: none"> Unselect the Enable Admin Node discovery check box. Enter the IP address manually. Click Save. Wait for the connection state for the new IP address to become ready.
Automatic discovery of all connected primary Admin Nodes	<ol style="list-style-type: none"> Select the Enable Admin Node discovery check box. Wait for the list of discovered IP addresses to be displayed. Select the primary Admin Node for the grid where this appliance Storage Node will be deployed. Click Save. Wait for the connection state for the new IP address to become ready.

- In the **Node name** field, enter the name you want to use for this appliance node, and click **Save**.

The node name is assigned to this appliance node in the StorageGRID system. It is shown on the Nodes page (Overview tab) in the Grid Manager. If required, you can change the name when you approve the node.

- In the Installation section, confirm that the current state is "Ready to start installation of *node name* into grid with primary Admin Node *admin_ip*" and that the **Start Installation** button is enabled.

If the **Start Installation** button is not enabled, you might need to change the network configuration or port settings. For instructions, see the installation and maintenance instructions for your appliance.



If you are deploying the Storage Node appliance as a node cloning target, stop the deployment process here and continue the node cloning procedure in recovery and maintenance.

Maintain & recover

- From the StorageGRID Appliance Installer home page, click **Start Installation**.

The Current state changes to "Installation is in progress," and the Monitor Installation page is displayed.



If you need to access the Monitor Installation page manually, click **Monitor Installation**.

- If your grid includes multiple appliance Storage Nodes, repeat these steps for each appliance.



If you need to deploy multiple appliance Storage Nodes at one time, you can automate the installation process by using the `configure-sga.py` appliance installation script. This script applies only to Storage Nodes.

Related information

[Expand your grid](#)

[Maintain & recover](#)

Monitoring the storage appliance installation

The StorageGRID Appliance Installer provides status until installation is complete. When the software installation is complete, the appliance is rebooted.

Steps

1. To monitor the installation progress, click **Monitor Installation**.

The Monitor Installation page shows the installation progress.

Monitor Installation

1. Configure storage		Running
Step	Progress	Status
Connect to storage controller	<div style="width: 100%; height: 10px; background-color: green;"></div>	Complete
Clear existing configuration	<div style="width: 100%; height: 10px; background-color: green;"></div>	Complete
Configure volumes	<div style="width: 30%; height: 10px; background-color: blue;"></div>	Creating volume StorageGRID-obj-00
Configure host settings	<div style="width: 0%; height: 10px; background-color: blue;"></div>	Pending

2. Install OS	Pending
3. Install StorageGRID	Pending
4. Finalize installation	Pending

The blue status bar indicates which task is currently in progress. Green status bars indicate tasks that have completed successfully.



The installer ensures that tasks completed in a previous install are not re-run. If you are re-running an installation, any tasks that do not need to be re-run are shown with a green status bar and a status of "Skipped."

2. Review the progress of the first two installation stages.

1. Configure storage

During this stage, the installer connects to the storage controller, clears any existing configuration, communicates with SANtricity software to configure volumes, and configures host settings.

2. Install OS

During this stage, the installer copies the base operating system image for StorageGRID to the appliance.

3. Continue monitoring the installation progress until the **Install StorageGRID** stage pauses and a message

appears on the embedded console, prompting you to approve this node on the Admin Node using the Grid Manager. Go to the next step.

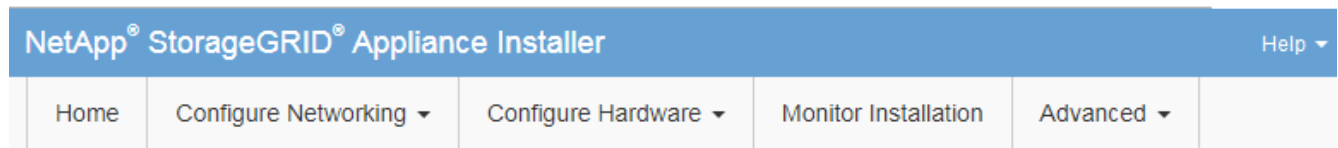

Monitor Installation

1. Configure storage	Complete
2. Install OS	Complete
3. Install StorageGRID	Running
4. Finalize installation	Pending

```

Connected (unencrypted) to: QEMU
/platform.type: Device or resource busy
[2017-07-31T22:09:12.362566] INFO -- [INSG] NOTICE: seeding /var/local with c
ontainer data
[2017-07-31T22:09:12.366205] INFO -- [INSG] Fixing permissions
[2017-07-31T22:09:12.369633] INFO -- [INSG] Enabling syslog
[2017-07-31T22:09:12.511533] INFO -- [INSG] Stopping system logging: syslog-n
g.
[2017-07-31T22:09:12.570096] INFO -- [INSG] Starting system logging: syslog-n
g.
[2017-07-31T22:09:12.576360] INFO -- [INSG] Beginning negotiation for downloa
d of node configuration
[2017-07-31T22:09:12.581363] INFO -- [INSG]
[2017-07-31T22:09:12.585066] INFO -- [INSG]
[2017-07-31T22:09:12.588314] INFO -- [INSG]
[2017-07-31T22:09:12.591851] INFO -- [INSG]
[2017-07-31T22:09:12.594886] INFO -- [INSG]
[2017-07-31T22:09:12.598360] INFO -- [INSG]
[2017-07-31T22:09:12.601324] INFO -- [INSG]
[2017-07-31T22:09:12.604759] INFO -- [INSG]
[2017-07-31T22:09:12.607800] INFO -- [INSG]
[2017-07-31T22:09:12.610985] INFO -- [INSG]
[2017-07-31T22:09:12.614597] INFO -- [INSG]
[2017-07-31T22:09:12.618282] INFO -- [INSG] Please approve this node on the A
dmin Node GMI to proceed...

```

- Go to the Grid Manager, approve the pending storage node, and complete the StorageGRID installation process.

When you click **Install** from the Grid Manager, Stage 3 completes and stage 4, **Finalize Installation**, begins. When stage 4 completes, the controller is rebooted.

Automating appliance installation and configuration

You can automate the installation and configuration of your appliances and configuration

of the whole StorageGRID system.

About this task

Automating installation and configuration can be useful for deploying multiple StorageGRID instances or one large, complex StorageGRID instance.

To automate installation and configuration, use one or more of the following options:

- Create a JSON file that specifies the configuration settings for your appliances. Upload the JSON file using the StorageGRID Appliance Installer.



You can use the same file to configure more than one appliance.

- Use the `StorageGRIDconfigure-sga.py` Python script to automate the configuration of your appliances.
- Use additional Python scripts to configure other components of the whole StorageGRID system (the "grid").



You can use StorageGRID automation Python scripts directly, or you can use them as examples of how to use the StorageGRID Installation REST API in grid deployment and configuration tools you develop yourself. See the information about downloading and extracting the StorageGRID installation files in the Recovery and Maintenance instructions.

Automating appliance configuration using the StorageGRID Appliance Installer

You can automate the configuration of an appliance by using a JSON file that contains the configuration information. You upload the file using the StorageGRID Appliance Installer.

What you'll need

- Your appliance must be on the latest firmware compatible with StorageGRID 11.5 or higher.
- You must be connected to the StorageGRID Appliance Installer on the appliance you are configuring using a supported browser.

About this task

You can automate appliance configuration tasks such as configuring the following:

- Grid Network, Admin Network, and Client Network IP addresses
- BMC interface
- Network links
 - Port bond mode
 - Network bond mode
 - Link speed

Configuring your appliance using an uploaded JSON file is often more efficient than performing the configuration manually using multiple pages in the StorageGRID Appliance Installer, especially if you have to configure many nodes. You must apply the configuration file for each node one at a time.



Experienced users who want to automate both the installation and configuration of their appliances can use the `configure-sga.py` script. [Automating installation and configuration of appliance nodes using the `configure-sga.py` script](#)

Steps

1. Generate the JSON file using one of the following methods:

- The ConfigBuilder application

[ConfigBuilder.netapp.com](#)

- The `configure-sga.py` appliance configuration script. You can download the script from StorageGRID Appliance Installer (**Help > Appliance Configuration Script**). See the instructions on automating the configuration using the `configure-sga.py` script.

[Automating installation and configuration of appliance nodes using the `configure-sga.py` script](#)

The node names in the JSON file must follow these requirements:

- Must be a valid hostname containing at least 1 and no more than 32 characters
- Can use letters, numbers, and hyphens are allowed
- Cannot start or end with a hyphen or contain only numbers



Ensure that the node names (the top-level names) in the JSON file are unique, or you will not be able to configure more than one node using the JSON file.

2. Select **Advanced > Update Appliance Configuration**.

The Update Appliance Configuration page appears.

Update Appliance Configuration

Use a JSON file to update this appliance's configuration. You can generate the JSON file from the [ConfigBuilder](#) application or from the [appliance configuration script](#).

⚠ You might lose your connection if the applied configuration from the JSON file includes "link_config" and/or "networks" sections. If you are not reconnected within 1 minute, re-enter the URL using one of the other IP addresses assigned to the appliance.

Upload JSON

JSON configuration	<input type="button" value="Browse"/>
Node name	<input type="button" value="-- Upload a file"/>
<input type="button" value="Apply JSON configuration"/>	

3. Select the JSON file with the configuration you want to upload.

- a. Select **Browse**.
- b. Locate and select the file.
- c. Select **Open**.

The file is uploaded and validated. When the validation process is complete, the file name is shown next to a green check mark.



You might lose connection to the appliance if the configuration from the JSON file includes sections for "link_config", "networks", or both. If you are not reconnected within 1 minute, re-enter the appliance URL using one of the other IP addresses assigned to the appliance.

Upload JSON

JSON configuration	<input type="button" value="Browse"/>	✓ appliances.orig.json
Node name	-- Select a node ▼	
<input type="button" value="Apply JSON configuration"/>		

The **Node name** drop down is populated with the top-level node names defined in the JSON file.



If the file is not valid, the file name is shown in red and an error message is displayed in a yellow banner. The invalid file is not applied to the appliance. You can use ConfigBuilder to ensure you have a valid JSON file.

4. Select a node from the list in the **Node name** drop down.

The **Apply JSON configuration** button is enabled.

Upload JSON

JSON configuration	<input type="button" value="Browse"/>	✓ appliances.orig.json
Node name	Lab-80-1000 ▼	
<input type="button" value="Apply JSON configuration"/>		

5. Select **Apply JSON configuration**.

The configuration is applied to the selected node.

Automating installation and configuration of appliance nodes using the `configure-sga.py` script

You can use the `configure-sga.py` script to automate many of the installation and configuration tasks for StorageGRID appliance nodes, including installing and configuring a primary Admin Node. This script can be useful if you have a large number of appliances to configure. You can also use the script to generate a JSON file that contains appliance configuration information.

What you'll need

- The appliance has been installed in a rack, connected to your networks, and powered on.
- Network links and IP addresses have been configured for the primary Admin Node using the StorageGRID Appliance Installer.
- If you are installing the primary Admin Node, you know its IP address.
- If you are installing and configuring other nodes, the primary Admin Node has been deployed, and you know its IP address.
- For all nodes other than the primary Admin Node, all Grid Network subnets listed on the IP Configuration page of the StorageGRID Appliance Installer have been defined in the Grid Network Subnet List on the primary Admin Node.
- You have downloaded the `configure-sga.py` file. The file is included in the installation archive, or you can access it by clicking **Help > Appliance Installation Script** in the StorageGRID Appliance Installer.



This procedure is for advanced users with some experience using command-line interfaces. Alternatively, you can also use the StorageGRID Appliance Installer to automate the configuration.

[Automating appliance configuration using the StorageGRID Appliance Installer](#)

Steps

1. Log in to the Linux machine you are using to run the Python script.
2. For general help with the script syntax and to see a list of the available parameters, enter the following:

```
configure-sga.py --help
```

The `configure-sga.py` script uses five subcommands:

- `advanced` for advanced StorageGRID appliance interactions, including BMC configuration and creating a JSON file containing the current configuration of the appliance
- `configure` for configuring the RAID mode, node name, and networking parameters
- `install` for starting a StorageGRID installation
- `monitor` for monitoring a StorageGRID installation
- `reboot` for rebooting the appliance

If you enter a subcommand (`advanced`, `configure`, `install`, `monitor`, or `reboot`) argument followed by the `--help` option you will get a different help text providing more detail on the options available within that subcommand:

```
configure-sga.py subcommand --help
```

3. To confirm the current configuration of the appliance node, enter the following where *SGA-install-ip* is any one of the IP addresses for the appliance node:

```
configure-sga.py configure SGA-INSTALL-IP
```

The results show current IP information for the appliance, including the IP address of the primary Admin Node and information about the Admin, Grid, and Client Networks.

```
Connecting to +https://10.224.2.30:8443+ (Checking version and
connectivity.)
2021/02/25 16:25:11: Performing GET on /api/versions... Received 200
2021/02/25 16:25:11: Performing GET on /api/v2/system-info... Received
200
2021/02/25 16:25:11: Performing GET on /api/v2/admin-connection...
Received 200
2021/02/25 16:25:11: Performing GET on /api/v2/link-config... Received
200
2021/02/25 16:25:11: Performing GET on /api/v2/networks... Received 200
2021/02/25 16:25:11: Performing GET on /api/v2/system-config... Received
200
```

StorageGRID Appliance

```
Name:          LAB-SGA-2-30
Node type:     storage
```

StorageGRID primary Admin Node

```
IP:           172.16.1.170
State:        unknown
Message:      Initializing...
Version:      Unknown
```

Network Link Configuration

Link Status

Link	State	Speed (Gbps)
----	-----	-----
1	Up	10
2	Up	10
3	Up	10
4	Up	10
5	Up	1
6	Down	N/A

Link Settings

```
Port bond mode:    FIXED
Link speed:        10GBE
```

```

Grid Network:      ENABLED
  Bonding mode:    active-backup
  VLAN:            novlan
  MAC Addresses:   00:a0:98:59:8e:8a  00:a0:98:59:8e:82

Admin Network:    ENABLED
  Bonding mode:    no-bond
  MAC Addresses:   00:80:e5:29:70:f4

Client Network:   ENABLED
  Bonding mode:    active-backup
  VLAN:            novlan
  MAC Addresses:   00:a0:98:59:8e:89  00:a0:98:59:8e:81

```

Grid Network

```

CIDR:      172.16.2.30/21 (Static)
MAC:       00:A0:98:59:8E:8A
Gateway:   172.16.0.1
Subnets:  172.17.0.0/21
           172.18.0.0/21
           192.168.0.0/21
MTU:       1500

```

Admin Network

```

CIDR:      10.224.2.30/21 (Static)
MAC:       00:80:E5:29:70:F4
Gateway:   10.224.0.1
Subnets:  10.0.0.0/8
           172.19.0.0/16
           172.21.0.0/16
MTU:       1500

```

Client Network

```

CIDR:      47.47.2.30/21 (Static)
MAC:       00:A0:98:59:8E:89
Gateway:   47.47.0.1
MTU:       2000

```

```

#####
##### If you are satisfied with this configuration, #####
##### execute the script with the "install" sub-command. #####
#####

```

4. If you need to change any of the values in the current configuration, use the `configure` subcommand to update them. For example, if you want to change the IP address that the appliance uses for connection to the primary Admin Node to `172.16.2.99`, enter the following:

```
configure-sga.py configure --admin-ip 172.16.2.99 SGA-INSTALL-IP
```

5. If you want to back up the appliance configuration to a JSON file, use the `advanced` and `backup-file` subcommands. For example, if you want to back up the configuration of an appliance with IP address `SGA-INSTALL-IP` to a file named `appliance-SG1000.json`, enter the following:

```
configure-sga.py advanced --backup-file appliance-SG1000.json SGA-INSTALL-IP
```

The JSON file containing the configuration information is written to the same directory you executed the script from.



Check that the top-level node name in the generated JSON file matches the appliance name. Do not make any changes to this file unless you are an experienced user and have a thorough understanding of StorageGRID APIs.

6. When you are satisfied with the appliance configuration, use the `install` and `monitor` subcommands to install the appliance:

```
configure-sga.py install --monitor SGA-INSTALL-IP
```

7. If you want to reboot the appliance, enter the following:

```
configure-sga.py reboot SGA-INSTALL-IP
```

Automating the configuration of StorageGRID

After deploying the grid nodes, you can automate the configuration of the StorageGRID system.

What you'll need

- You know the location of the following files from the installation archive.

Filename	Description
<code>configure-storagegrid.py</code>	Python script used to automate the configuration
<code>configure-storagegrid.sample.json</code>	Sample configuration file for use with the script
<code>configure-storagegrid.blank.json</code>	Blank configuration file for use with the script

- You have created a `configure-storagegrid.json` configuration file. To create this file, you can modify the sample configuration file (`configure-storagegrid.sample.json`) or the blank configuration file (`configure-storagegrid.blank.json`).

About this task

You can use the `configure-storagegrid.py` Python script and the `configure-storagegrid.json` configuration file to automate the configuration of your StorageGRID system.



You can also configure the system using the Grid Manager or the Installation API.

Steps

1. Log in to the Linux machine you are using to run the Python script.

2. Change to the directory where you extracted the installation archive.

For example:

```
cd StorageGRID-Webscale-version/platform
```

where *platform* is *debs*, *rpms*, or *vsphere*.

3. Run the Python script and use the configuration file you created.

For example:

```
./configure-storagegrid.py ./configure-storagegrid.json --start-install
```

After you finish

A Recovery Package `.zip` file is generated during the configuration process, and it is downloaded to the directory where you are running the installation and configuration process. You must back up the Recovery Package file so that you can recover the StorageGRID system if one or more grid nodes fails. For example, copy it to a secure, backed up network location and to a secure cloud storage location.



The Recovery Package file must be secured because it contains encryption keys and passwords that can be used to obtain data from the StorageGRID system.

If you specified that random passwords should be generated, you need to extract the `Passwords.txt` file and look for the passwords required to access your StorageGRID system.

```
#####  
##### The StorageGRID "recovery package" has been downloaded as: #####  
#####      ./sgws-recovery-package-994078-rev1.zip      #####  
##### Safeguard this file as it will be needed in case of a #####  
#####      StorageGRID node recovery.      #####  
#####
```

Your StorageGRID system is installed and configured when a confirmation message is displayed.

```
StorageGRID has been configured and installed.
```

Overview of installation REST APIs

StorageGRID provides two REST APIs for performing installation tasks: the StorageGRID Installation API and the StorageGRID Appliance Installer API.

Both APIs use the Swagger open source API platform to provide the API documentation. Swagger allows both developers and non-developers to interact with the API in a user interface that illustrates how the API responds to parameters and options. This documentation assumes that you are familiar with standard web technologies and the JSON (JavaScript Object Notation) data format.



Any API operations you perform using the API Docs webpage are live operations. Be careful not to create, update, or delete configuration data or other data by mistake.

Each REST API command includes the API's URL, an HTTP action, any required or optional URL parameters, and an expected API response.

StorageGRID Installation API

The StorageGRID Installation API is only available when you are initially configuring your StorageGRID system, and in the event that you need to perform a primary Admin Node recovery. The Installation API can be accessed over HTTPS from the Grid Manager.

To access the API documentation, go to the installation web page on the primary Admin Node and select **Help > API Documentation** from the menu bar.

The StorageGRID Installation API includes the following sections:

- **config** — Operations related to the product release and versions of the API. You can list the product release version and the major versions of the API supported by that release.
- **grid** — Grid-level configuration operations. You can get and update grid settings, including grid details, Grid Network subnets, grid passwords, and NTP and DNS server IP addresses.
- **nodes** — Node-level configuration operations. You can retrieve a list of grid nodes, delete a grid node, configure a grid node, view a grid node, and reset a grid node's configuration.
- **provision** — Provisioning operations. You can start the provisioning operation and view the status of the provisioning operation.
- **recovery** — Primary Admin Node recovery operations. You can reset information, upload the Recover Package, start the recovery, and view the status of the recovery operation.
- **recovery-package** — Operations to download the Recovery Package.
- **sites** — Site-level configuration operations. You can create, view, delete, and modify a site.

StorageGRID Appliance Installer API

The StorageGRID Appliance Installer API can be accessed over HTTPS from `Controller_IP:8443`.

To access the API documentation, go to the StorageGRID Appliance Installer on the appliance and select **Help > API Docs** from the menu bar.

The StorageGRID Appliance Installer API includes the following sections:

- **clone** — Operations to configure and control node cloning.
- **encryption** — Operations to manage encryption and view encryption status.
- **hardware configuration** — Operations to configure system settings on attached hardware.
- **installation** — Operations for starting the appliance installation and for monitoring installation status.
- **networking** — Operations related to the Grid, Admin, and Client Network configuration for a StorageGRID appliance and appliance port settings.
- **setup** — Operations to help with initial appliance installation setup including requests to get information about the system and update the primary Admin Node IP.
- **support** — Operations for rebooting the controller and getting logs.

- **upgrade** — Operations related to upgrading appliance firmware.
- **uploadsg** — Operations for uploading StorageGRID installation files.

Troubleshooting the hardware installation

If you encounter issues during the installation, you might find it helpful to review troubleshooting information related to hardware setup and connectivity issues.

Related information

[Hardware setup appears to hang](#)

[Troubleshooting connection issues](#)

Hardware setup appears to hang

The StorageGRID Appliance Installer might not be available if hardware faults or cabling errors prevent the E5600SG controller from completing its boot-up processing.

Steps

1. Check the Needs Attention LED on either controller and look for a flashing error code.

During power up, the Service Action Allowed and Service Action Required LEDs are turned on while the hardware is initializing. The upper decimal point of the lower digit, called the *diagnostic LED*, also illuminates. The seven-segment display runs through a sequence of codes that are common for both controllers. This is normal and is not an indication of an error. When the hardware boots successfully, the Service Action LEDs are turned off, and the displays are driven by the firmware.

2. Review the codes on the seven-segment display for the E5600SG controller.



The installation and provisioning take time. Some installation phases do not report updates to the StorageGRID Appliance Installer for several minutes.

If an error occurs, the seven-segment display flashes a sequence, such as HE.

3. To understand what these codes mean, see the following resources:

Controller	Reference
E5600SG controller	<ul style="list-style-type: none"> • “HE error: Error synchronizing with SANtricity OS Software” • “E5600SG controller seven-segment display codes”
E2700 controller	<p>E-Series documentation</p> <p>Note: The codes described for the E-Series E5600 controller do not apply to the E5600SG controller in the appliance.</p>

4. If this does not resolve the issue, contact technical support.

Related information

[E5600SG controller seven-segment display codes](#)

[HE error: Error synchronizing with SANtricity OS Software](#)

[E2700 Controller-Drive Tray and Related Drive Trays Installation Guide](#)

[NetApp Documentation: E2700 Series](#)

HE error: Error synchronizing with SANtricity OS Software

The seven-segment display on the compute controller shows an HE error code if the StorageGRID Appliance Installer cannot synchronize with SANtricity OS Software.

About this task

If an HE error code is displayed, perform this corrective action.

Steps

1. Check the integrity of the two SAS interconnect cables, and confirm they are securely connected.
2. As required, replace one or both of the cables, and try again.
3. If this does not resolve the issue, contact technical support.

Troubleshooting connection issues

If you encounter connection issues during the StorageGRID appliance installation, you should perform the corrective action steps listed.

Unable to connect to StorageGRID appliance over the network

If you cannot connect to the appliance, there might be a network issue, or the hardware installation might not have been completed successfully.

- **Issue**

You cannot connect to the appliance.

- **Cause**

This could occur if there is a network issue or the hardware installation did not complete successfully.

- **Corrective action**

- a. Ping the appliance:

```
ping E5600_controller_IP
```

- b. Access the StorageGRID Appliance Installer by opening a browser and entering the following:

```
https://Management_Port_IP:8443
```

For Management_Port_IP, enter the IP address for management port 1 on the E5600SG controller (provisioned during the physical installation).

- c. Click **Configure Admin network**, and check the IP.

- d. If you receive a response from the ping, check that port 8443 is open in the firewalls.
- e. Reboot the appliance.
- f. Refresh the installation web page.
- g. If this does not resolve the connection issue, contact technical support from the NetApp Support Site at mysupport.netapp.com.

Related information

[E5600SG controller seven-segment display codes](#)

Rebooting the controller while the StorageGRID Appliance Installer is running

You might need to reboot the compute controller while the StorageGRID Appliance Installer is running. For example, you might need to reboot the controller if the installation fails.

About this task

This procedure only applies when the compute controller is running the StorageGRID Appliance Installer. Once the installation is completed, this step no longer works because the StorageGRID Appliance Installer is no longer available.

Steps

1. From the StorageGRID Appliance Installer, click **Advanced** > **Reboot Controller**, and then select one of these options:
 - Select **Reboot into StorageGRID** to reboot the controller with the node rejoining the grid. Select this option if you are done working in maintenance mode and are ready to return the node to normal operation.
 - Select **Reboot into Maintenance Mode** to reboot the controller with the node remaining in maintenance mode. Select this option if there are additional maintenance operations you need to perform on the node before rejoining the grid.



The SG6000-CN controller is rebooted.

Maintaining the SG5600 appliance

You might need to upgrade the SANtricity OS Software on the E2700 controller, replace

the E2700 controller or the E5600SG controller, or replace specific components. The procedures in this section assume that the appliance has already been deployed as a Storage Node in a StorageGRID system.

Steps

- [Placing an appliance into maintenance mode](#)
- [Upgrading SANtricity OS on the storage controllers using the Grid Manager](#)
- [Upgrading SANtricity OS on the E2700 controller using maintenance mode](#)
- [Upgrading drive firmware using SANtricity Storage Manager](#)
- [Replacing the E2700 controller](#)
- [Replacing the E5600SG controller](#)
- [Replacing other hardware components](#)
- [Changing the link configuration of the E5600SG controller](#)
- [Changing the MTU setting](#)
- [Checking the DNS server configuration](#)
- [Monitoring node encryption in maintenance mode](#)

Placing an appliance into maintenance mode

You must place the appliance into maintenance mode before performing specific maintenance procedures.

What you'll need

- You must be signed in to the Grid Manager using a supported browser.
- You must have the Maintenance or Root Access permission. For details, see the instructions for administering StorageGRID.

About this task

Placing a StorageGRID appliance into maintenance mode might make the appliance unavailable for remote access.



The password and host key for a StorageGRID appliance in maintenance mode remain the same as they were when the appliance was in service.

Steps

1. From the Grid Manager, select **Nodes**.
2. From the tree view of the Nodes page, select the appliance Storage Node.
3. Select **Tasks**.

Reboot

Shuts down and restarts the node.

Reboot

Maintenance Mode

Places the appliance's compute controller into maintenance mode.

Maintenance Mode

4. Select **Maintenance Mode**.

A confirmation dialog box appears.

⚠ Enter Maintenance Mode on SGA-106-15

You must place the appliance's compute controller into maintenance mode to perform certain maintenance procedures on the appliance.

Attention: All StorageGRID services on this node will be shut down. Wait a few minutes for the node to reboot into maintenance mode.

If you are ready to start, enter the provisioning passphrase and click OK.

Provisioning Passphrase

Cancel

OK

5. Enter the provisioning passphrase, and select **OK**.

A progress bar and a series of messages, including "Request Sent," "Stopping StorageGRID," and "Rebooting," indicate that the appliance is completing the steps for entering maintenance mode.

Reboot

Shuts down and restarts the node.

Reboot

Maintenance Mode

Attention: Your request has been sent, but the appliance might take 10-15 minutes to enter maintenance mode. Do not perform maintenance procedures until this tab indicates maintenance mode is ready, or data could become corrupted.

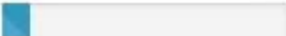
 Request Sent

When the appliance is in maintenance mode, a confirmation message lists the URLs you can use to access the StorageGRID Appliance Installer.

Reboot

Shuts down and restarts the node.

Reboot

Maintenance Mode

This node is currently in maintenance mode. Navigate to one of the URLs listed below and perform any necessary maintenance procedures.

- <https://172.16.2.106:8443>
- <https://10.224.2.106:8443>
- <https://47.47.2.106:8443>
- <https://169.254.0.1:8443>

When you are done with any required maintenance procedures, you must exit maintenance mode by clicking Reboot Controller from the StorageGRID Appliance Installer.

6. To access the StorageGRID Appliance Installer, browse to any of the URLs displayed.

If possible, use the URL containing the IP address of the appliance's Admin Network port.



Accessing <https://169.254.0.1:8443> requires a direct connection to the local management port.

7. From the StorageGRID Appliance Installer, confirm that the appliance is in maintenance mode.

⚠ This node is in maintenance mode. Perform any required maintenance procedures. If you want to exit maintenance mode manually to resume normal operation, go to **Advanced > Reboot Controller** to **reboot** the controller.

8. Perform any required maintenance tasks.
9. After completing maintenance tasks, exit maintenance mode and resume normal node operation. From the StorageGRID Appliance Installer, select **Advanced > Reboot Controller**, and then select **Reboot into StorageGRID**.

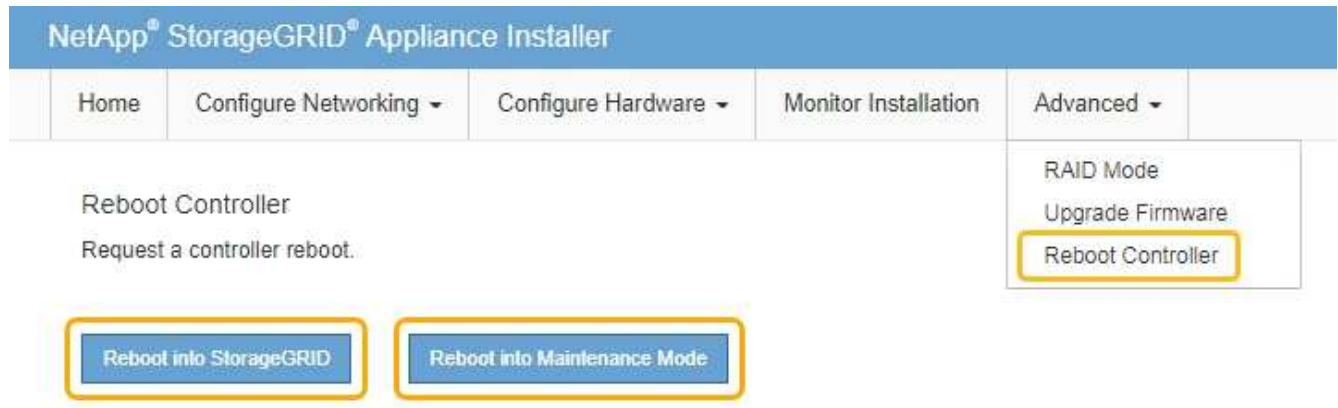

It can take up to 20 minutes for the appliance to reboot and rejoin the grid. To confirm that the reboot is complete and that the node has rejoined the grid, go back to the Grid Manager. The **Nodes** tab should display a normal status ✓ for the appliance node, indicating that no alerts are active and the node is connected to the grid.

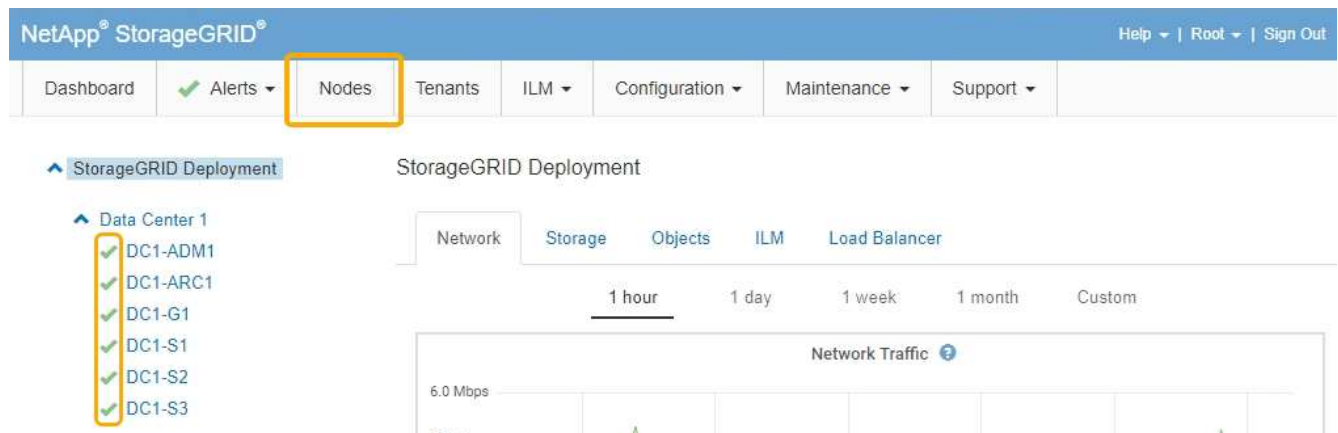

Upgrading SANtricity OS on the storage controllers using the Grid Manager

Use the Grid Manager to apply a SANtricity OS upgrade.

What you'll need

- You have consulted the NetApp Interoperability Matrix Tool (IMT) to confirm that the SANtricity OS version you are using for the upgrade is compatible with your appliance.
- You must have the Maintenance permission.

- You must be signed in to the Grid Manager using a supported browser.
- You must have the provisioning passphrase.
- You must have access to the NetApp downloads page for SANtricity OS.

About this task

You cannot perform other software updates (StorageGRID software upgrade or a hotfix) until you have completed the SANtricity OS upgrade process. If you attempt to start a hotfix or a StorageGRID software upgrade before the SANtricity OS upgrade process has finished, you are redirected to the SANtricity OS upgrade page.

The procedure will not be complete until the SANtricity OS upgrade has been successfully applied to all applicable nodes. It might take more than 30 minutes to load the SANtricity OS on each node and up to 90 minutes to reboot each StorageGRID storage appliance.



The following steps are only applicable when you are using the Grid Manager to perform the upgrade.



This procedure will automatically upgrade the NVSRAM to the most recent version associated with the SANtricity OS upgrade. You do not need to apply a separate NVSRAM upgrade file.

Steps

1. From a service laptop, download the new SANtricity OS file from the NetApp support site.

Be sure to choose the SANtricity OS version for the E2700 storage controller.

2. Sign in to the Grid Manager using a supported browser.
3. Select **Maintenance**. Then, in the System section of the menu, select **Software Update**.

The Software Update page appears.

Software Update

You can upgrade StorageGRID software, apply a hotfix, or upgrade the SANtricity OS software on StorageGRID storage appliances.

- To perform a major version upgrade of StorageGRID, see the [instructions for upgrading StorageGRID](#), and then select **StorageGRID Upgrade**.
- To apply a hotfix to all nodes in your system, see "Hotfix procedure" in the [recovery and maintenance instructions](#), and then select **StorageGRID Hotfix**.
- To upgrade SANtricity OS software on a storage controller, see "Upgrading SANtricity OS Software on the storage controllers" in the installation and maintenance instructions for your storage appliance, and then select **SANtricity OS**:

[SG6000 appliance installation and maintenance](#)

[SG5700 appliance installation and maintenance](#)

[SG5600 appliance installation and maintenance](#)



4. Click **SANtricity OS**.

The SANtricity OS page appears.

SANtricity OS

You can use this page to upgrade the SANtricity OS software on storage controllers in a storage appliance. Before installing the new software, confirm the storage controllers are Nominal (**Nodes > appliance node > Hardware**) and ready for an upgrade. A health check is automatically performed as part of the upgrade process and valid NVSRAM is automatically installed based on the appliance type and new software version. The software upgrade can take up to 30 minutes per appliance. When the upgrade is complete, the node will be automatically rebooted to activate the SANtricity OS on the storage controllers. If you have multiple types of appliances, repeat this procedure to install the appropriate OS software for each type.

SANtricity OS Upgrade File

SANtricity OS Upgrade File



Browse

Passphrase

Provisioning Passphrase



Start

5. Select the SANtricity OS upgrade file you downloaded from the NetApp support site.
 - a. Click **Browse**.
 - b. Locate and select the file.
 - c. Click **Open**.

The file is uploaded and validated. When the validation process is done, the file name is shown in the Details field.



Do not change the file name since it is part of the verification process.

SANtricity OS

You can use this page to upgrade the SANtricity OS software on storage controllers in a storage appliance. Before installing the new software, confirm the storage controllers are Nominal (**Nodes > appliance node > Hardware**) and ready for an upgrade. A health check is automatically performed as part of the upgrade process and valid NVSRAM is automatically installed based on the appliance type and new software version. The software upgrade can take up to 30 minutes per appliance. When the upgrade is complete, the node will be automatically rebooted to activate the SANtricity OS on the storage controllers. If you have multiple types of appliances, repeat this procedure to install the appropriate OS software for each type.

SANtricity OS Upgrade File

SANtricity OS Upgrade File



Browse

✓ RC_20240301_1.0_140_040_2701 .dlp

Details



RC_20240301_1.0_140_040_2701 .dlp

Passphrase

Provisioning Passphrase



Start

6. Enter the provisioning passphrase.

The **Start** button is enabled.

SANtricity OS

You can use this page to upgrade the SANtricity OS software on storage controllers in a storage appliance. Before installing the new software, confirm the storage controllers are Nominal (**Nodes > appliance node > Hardware**) and ready for an upgrade. A health check is automatically performed as part of the upgrade process and valid NVSRAM is automatically installed based on the appliance type and new software version. The software upgrade can take up to 30 minutes per appliance. When the upgrade is complete, the node will be automatically rebooted to activate the SANtricity OS on the storage controllers. If you have multiple types of appliances, repeat this procedure to install the appropriate OS software for each type.

SANtricity OS Upgrade File

SANtricity OS Upgrade File



Browse

✓ RC_20240301_1.0_140_040_2701 .dlp

Details



RC_20240301_1.0_140_040_2701 .dlp

Passphrase

Provisioning Passphrase



Start

7. Click **Start**.

A warning box appears stating that your browser's connection might be lost temporarily as services on nodes that are upgraded are restarted.

Warning

Nodes can disconnect and services might be affected

The node will be automatically rebooted at the end of upgrade and services will be affected. Are you sure you want to start the SANtricity OS upgrade?

Cancel OK

8. Click **OK** to stage the SANtricity OS upgrade file to the primary Admin Node.

When the SANtricity OS upgrade starts:

a. The health check is run. This process checks that no nodes have the status of Needs Attention.

 If any errors are reported, resolve them and click **Start** again.

b. The SANtricity OS Upgrade Progress table appears. This table shows all Storage Nodes in your grid and the current stage of the upgrade for each node.

 The table shows all Storage Nodes, including software-based Storage Nodes. You must approve the upgrade for all Storage Nodes, even though a SANtricity OS upgrade has no effect on software-based Storage Nodes. The upgrade message returned for software-based Storage Nodes is "SANtricity OS upgrade is not applicable to this node."

SANtricity OS Upgrade Progress

Approve All Remove All

Storage Nodes - 0 out of 4 completed

Approve All Remove All

Search

Site	Name	Progress	Stage	Details	Action
RTP Lab 1	DT-10-224-1-181-S1		Waiting for you to approve		Approve
RTP Lab 1	DT-10-224-1-182-S2		Waiting for you to approve		Approve
RTP Lab 1	DT-10-224-1-183-S3		Waiting for you to approve		Approve
RTP Lab 1	NetApp-SGA-Lab2-002-024		Waiting for you to approve		Approve

Navigation arrows: < >

9. Optionally, sort the list of nodes in ascending or descending order by **Site**, **Name**, **Progress**, **Stage**, or **Details**. Or, enter a term in the **Search** box to search for specific nodes.

You can scroll through the list of nodes by using the left and right arrows at the bottom right corner of the section.

10. Approve the grid nodes you are ready to add to the upgrade queue. Approved nodes of the same type are upgraded one at a time.



Do not approve the SANtricity OS upgrade for an appliance storage node unless you are sure the node is ready to be stopped and rebooted. When the SANtricity OS upgrade is approved on a node, the services on that node are stopped. Later, when the node is upgraded, the appliance node is rebooted. These operations might cause service interruptions for clients that are communicating with the node.

- Click either of the **Approve All** buttons to add all Storage Nodes to the SANtricity OS upgrade queue.



If the order in which nodes are upgraded is important, approve nodes or groups of nodes one at a time and wait until the upgrade is complete on each node before approving the next node(s).

- Click one or more **Approve** buttons to add one or more nodes to the SANtricity OS upgrade queue.



You can delay applying a SANtricity OS upgrade to a node, but the SANtricity OS upgrade process will not be complete until you approve the SANtricity OS upgrade on all the listed Storage Nodes.

After you click **Approve**, the upgrade process determines if the node can be upgraded. If a node can be upgraded, it is added to the upgrade queue.

For some nodes, the selected upgrade file is intentionally not applied and you can complete the upgrade process without upgrading these specific nodes. For nodes intentionally not upgraded, the process will show stage of Complete with one of the following messages in the Details column:

- Storage Node was already upgraded.
- SANtricity OS upgrade is not applicable to this node.
- SANtricity OS file is not compatible with this node.

The message “SANtricity OS upgrade is not applicable to this node” indicates that the node does not have a storage controller that can be managed by the StorageGRID system. This message will appear for non-appliance Storage Nodes. You can complete the SANtricity OS upgrade process without upgrading the node displaying this message.

The message “SANtricity OS file is not compatible with this node” indicates that the node requires a SANtricity OS file different than the one the process is attempting to install. After you complete the current SANtricity OS upgrade, download the SANtricity OS appropriate for the node and repeat the upgrade process.

11. If you need to remove a node or all nodes from the SANtricity OS upgrade queue, click **Remove** or **Remove All**.

As shown in the example, when the stage progresses beyond Queued, the **Remove** button is hidden and you can no longer remove the node from the SANtricity OS upgrade process.

Storage Nodes - 1 out of 9 completed Approve All Remove All

Search

Site	Name	Progress	Stage	Details	Action
Raleigh	RAL-S1-101-196	<div style="width: 0%;"></div>	Queued		Remove
Raleigh	RAL-S2-101-197	<div style="width: 100%; background-color: green;"></div>	Complete		
Raleigh	RAL-S3-101-198	<div style="width: 0%;"></div>	Queued		Remove
Sunnyvale	SVL-S1-101-199	<div style="width: 0%;"></div>	Queued		Remove
Sunnyvale	SVL-S2-101-93	<div style="width: 0%;"></div>	Waiting for you to approve		Approve
Sunnyvale	SVL-S3-101-94	<div style="width: 0%;"></div>	Waiting for you to approve		Approve
Vancouver	VTC-S1-101-193	<div style="width: 0%;"></div>	Waiting for you to approve		Approve
Vancouver	VTC-S2-101-194	<div style="width: 0%;"></div>	Waiting for you to approve		Approve
Vancouver	VTC-S3-101-195	<div style="width: 0%;"></div>	Waiting for you to approve		Approve

12. Wait while the SANtricity OS upgrade is applied to each approved grid node.



If any node shows a stage of Error while the SANtricity OS upgrade is being applied, the upgrade has failed for that node. The appliance might need to be placed in maintenance mode to recover from the failure. Contact technical support before continuing.

If the firmware on the node is too old to be upgraded with the Grid Manager, the node shows a stage of Error with the details: "You must use maintenance mode to upgrade SANtricity OS on this node. See the installation and maintenance instructions for your appliance. After the upgrade, you can use this utility for future upgrades." To resolve the error, do the following:

- a. Use maintenance mode to upgrade SANtricity OS on the node that shows a stage of Error.
- b. Use the Grid Manager to re-start and complete the SANtricity OS upgrade.

When the SANtricity OS upgrade is complete on all approved nodes, the SANtricity OS Upgrade Progress table closes and a green banner shows the date and time the SANtricity OS upgrade was completed.

SANtricity OS upgrade completed at 2020-04-07 13:26:02 EDT.

SANtricity OS Upgrade File

SANtricity OS Upgrade File

Passphrase

Provisioning Passphrase

13. Repeat this upgrade procedure for any nodes with a stage of Complete that require a different SANtricity OS upgrade file.



For any nodes with a status of Needs Attention, use maintenance mode to perform the upgrade.

Related information

[Upgrading SANtricity OS on the E2700 controller using maintenance mode](#)

Upgrading SANtricity OS on the E2700 controller using maintenance mode

If you are unable to upgrade the SANtricity OS Software using the Grid Manager, use the maintenance mode procedure to apply the upgrade.

What you'll need

- You have consulted the NetApp Interoperability Matrix Tool (IMT) to confirm that the SANtricity OS version you are using for the upgrade is compatible with your appliance.
- You must place the E5600SG controller into maintenance mode if you are not using the Grid Manager. Placing the controller into maintenance mode interrupts the connection to the E2700 controller. Before changing the link configuration, you must place the E5600SG controller into maintenance mode. Putting a StorageGRID appliance into maintenance mode might make the appliance unavailable for remote access.

[Placing an appliance into maintenance mode](#)

About this task

Do not upgrade the SANtricity OS or NVSRAM in the E-Series controller on more than one StorageGRID appliance at a time.



Upgrading more than one StorageGRID appliance at a time might cause data unavailability, depending on your deployment model and ILM policies.

Steps

1. From a service laptop, access SANtricity Storage Manager, and sign in.
2. Download the new SANtricity OS Software file and NVSRAM file to the management client.



The NVSRAM is specific to the StorageGRID appliance. Do not use the standard NVSRAM download.

3. Follow the instructions in the *E2700 and E5600 SANtricity Software and Firmware Upgrade instructions* or the SANtricity Storage Manager online help, and upgrade the E2700 controller's firmware, NVSRAM, or both.



If you need to upgrade the NVSRAM in the E2700 controller, you must confirm that the SANtricity OS file you downloaded was designated as compatible with StorageGRID appliances.



Activate the upgrade files immediately. Do not defer activation.

4. Once the upgrade operation has completed, reboot the node. From the StorageGRID Appliance Installer, select **Advanced > Reboot Controller**, and then select one of these options:
 - Select **Reboot into StorageGRID** to reboot the controller with the node rejoining the grid. Select this

option if you are done working in maintenance mode and are ready to return the node to normal operation.

- Select **Reboot into Maintenance Mode** to reboot the controller with the node remaining in maintenance mode. Select this option if there are additional maintenance operations you need to perform on the node before rejoining the grid.

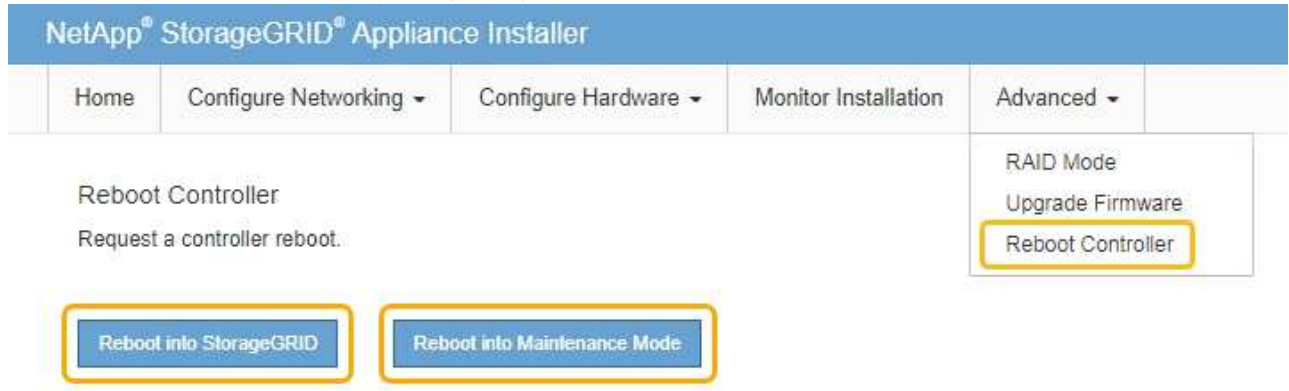

It can take up to 20 minutes for the appliance to reboot and rejoin the grid. To confirm that the reboot is complete and that the node has rejoined the grid, go back to the Grid Manager. The **Nodes** tab should display a normal status ✓ for the appliance node, indicating that no alerts are active and the node is connected to the grid.

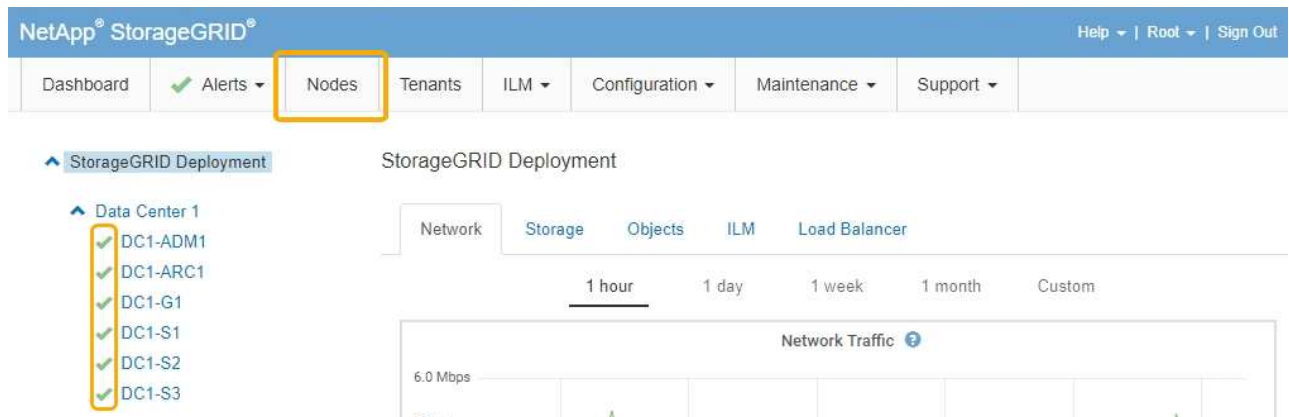

Upgrading drive firmware using SANtricity Storage Manager

You upgrade your drive firmware to make sure you have all the latest features and bug fixes.

What you'll need

- The storage appliance has an Optimal status.
- All drives have an Optimal status.
- You have the latest version of SANtricity Storage Manager installed that is compatible with your StorageGRID version.

[Upgrading SANtricity OS on the storage controllers using the Grid Manager](#)

[Upgrading SANtricity OS on the E2700 controller using maintenance mode](#)

- You have placed the StorageGRID appliance in maintenance mode.

Placing an appliance into maintenance mode



Maintenance mode interrupts the connection to the storage controller, stopping all I/O activity and placing all drives offline.



Do not upgrade the drive firmware on more than one StorageGRID appliance at a time. Doing so might cause data unavailability, depending on your deployment model and ILM policies.

Steps

1. Open a web browser, and enter the IP address as the URL for SANtricity Storage Manager:
https://E2700_Controller_IP
2. Enter the SANtricity Storage Manager administrator username and password, if required.
3. From SANtricity Enterprise Management, select the **Devices** tab.

The SANtricity Array Management window opens.

4. From SANtricity Array Management, double-click the Storage Array with the drives to upgrade.
5. Verify that both the Storage Array and drives have an Optimal status.
6. Verify the drive firmware version currently installed in the storage appliance:

- a. From SANtricity Enterprise Management, select **Upgrade > Drive Firmware**.

The Download Drive Firmware - Add Packages window displays the drive firmware files currently in use.

- b. Note current drive firmware revisions and drive identifiers under Current firmware packages.

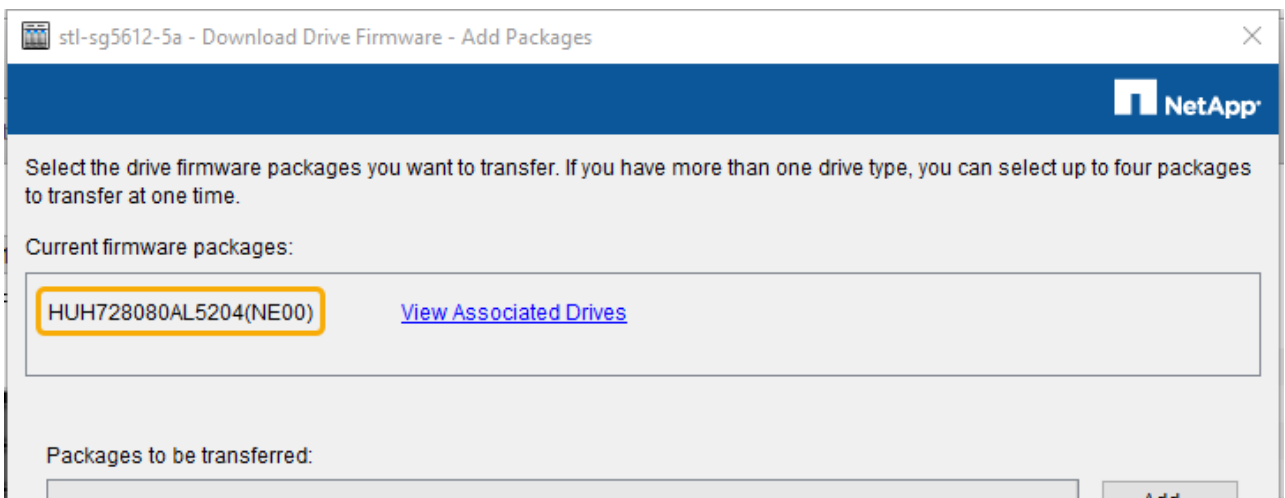

In this example:

- The drive firmware revision is **NE00**.
- The drive identifier is **HUH728080AL5204**.

Select **View Associated Drives** to display where these drives are installed in your storage appliance.

7. Download and prepare the available drive firmware upgrade:

- a. Open your web browser, navigate to NetApp Support web site, and log in using your ID and password.

[NetApp Support](#)

- b. On the NetApp Support web site, select the **Downloads** tab, and then select **E-Series Disk Drive Firmware**.

The E-Series Disk Firmware page displays.

- c. Search for each **Drive Identifier** installed in your storage appliance and verify that each drive identifier has the latest firmware revision.
 - If the firmware revision is not a link, this drive identifier has the latest firmware revision.
 - If one or more drive part numbers are listed for a drive identifier, a firmware upgrade is available for these drives. You can select any link to download the firmware file.

NetApp | Support

PRODUCTS ▾ SYSTEMS ▾ DOCS & KNOWLEDGEBASE ▾ COMMUNITY ▾ DOWNLOADS ▾ TOOLS ▾ CASES ▾ PARTS ▾

Downloads > Firmware > E-Series Disk Firmware

E-Series Disk Firmware

[Download all current E-Series Disk Firmware](#)

Drive Part Number	Descriptions	Drive Identifier	Firmware Rev. (Download)	Notes and Config Info	Release Date
<input type="text" value="Drive Part Number"/>	<input type="text" value="Descriptions"/>	<input type="text" value="HUH728080AL5204"/>	<input type="text" value="Firmware Rev. (Download)"/>		
E-X4073A	HDD, 8TB, SAS, 7.2K, PI	HUH728080AL5204	NE01	NE01 Fixes Bug 1122414	26-Jul-2018
E-X4074A	HDD, 8TB, SAS, 7.2K, PI	HUH728080AL5204	NE01	NE01 Fixes Bug 1122414	26-Jul-2018
E-X4127A	HDD, 8TB, SAS, 7.2K, PI	HUH728080AL5204	NE01	NE01 Fixes Bug 1122414	26-Jul-2018
E-X4128A	HDD, 8TB, SAS, 7.2K, PI	HUH728080AL5204	NE01	NE01 Fixes Bug 1122414	26-Jul-2018

- d. If a later firmware revision is listed, select the link in the Firmware Rev. (Download) column to download a .zip archive containing the firmware file.

- e. Extract (unzip) the drive firmware archive files you downloaded from the Support site.

8. Install the drive firmware upgrade:

- a. From the SANtricity Storage Manager Download Drive Firmware - Add Packages window, select **Add**.
- b. Navigate to the directory that contains the firmware files and select up to four firmware files.

Drive firmware files have a filename similar to

D_HUC101212CSS600_30602291_MS01_2800_0002.dlp

Selecting more than one firmware file to upgrade the firmware of the same drive might result in a file conflict error. If a file conflict error occurs, an error dialog appears. To resolve this error, select **OK** and remove all other firmware files except the one that you want to use for upgrading the firmware of the drive. To remove a firmware file, select the firmware file in the Packages to Be Transferred information area, and select **Remove**. In addition, you can only select up to four drive firmware packages at one time.

- c. Select **OK**.

The system updates the Packages to be transferred information area with the firmware files you selected.

d. Select **Next**.

The Download Drive Firmware - Select Drives window opens.

- All drives in the appliance are scanned for configuration information and upgrade eligibility.
- You are presented with a selection (depending on what variety of drives you have in the storage array) of compatible drives that can be upgraded with the firmware you selected. The drives capable of being upgraded as an online operation are displayed by default.
- The selected firmware for the drive appears in the Proposed Firmware information area. If you must change the firmware, select **Back** to return to the previous dialog.

e. From the Drive upgrade capability, select the **Parallel** download operation or **All**.

You can use either of these upgrade methods because the appliance is in maintenance mode, where I/O activity is stopped for all drives and all volumes.

f. In Compatible Drives, select the drives for which you want to upgrade the selected firmware files.

- For one or more drives, select each drive you want to upgrade.
- For all compatible drives, select **Select all**.

The best practice is to upgrade all drives of the same model to the same firmware revision.

g. Select **Finish**; then, type *yes* and select **OK**.

- The drive firmware download and upgrade begins, with Download Drive Firmware - Progress indicating the status of the firmware transfer for all drives.
- The status of each drive participating in the upgrade appears in the Transfer Progress column of Devices updated.

A parallel drive firmware upgrade operation can take as much as 90 seconds to complete if all drives are upgraded on a 24-drive system. On a larger system, the execution time is slightly longer.

h. During the firmware upgrade process, you can:

- Select **Stop** to stop the firmware upgrade in progress. Any firmware upgrade currently in progress are completed. Any drives that have attempted firmware upgrade show their individual status. Any remaining drives are listed with a status of Not attempted.



Stopping the drive firmware upgrade in process might result in data loss or unavailable drives.

- Select **Save As** to save a text report of the firmware upgrade progress summary. The report saves with a default .log file extension. If you want to change the file extension or directory, change the parameters in Save Drive Download Log.

i. Use Download Drive Firmware - Progress to monitor the progress of the drive firmware upgrades. The Drives Updated area contains a list of drives that are scheduled for firmware upgrade and the transfer status of each drive's download and upgrade.

The progress and status of each drive that is participating in the upgrade appears in the Transfer Progress column. Take the appropriate recommended action if any errors occur during the upgrade.

- **Pending**

This status is shown for an online firmware download operation that has been scheduled but has not yet started.

- **In progress**

The firmware is being transferred to the drive.

- **Reconstruction in progress**

This status is shown if a volume transfer takes place during the rapid reconstruction of a drive. This is typically due to a controller reset or failure and the controller owner transfers the volume.

The system will initiate a full reconstruction of the drive.

- **Failed - partial**

The firmware was only partially transferred to the drive before a problem prevented the rest of the file from being transferred.

- **Failed - invalid state**

The firmware is not valid.

- **Failed - other**

The firmware could not be downloaded, possibly because of a physical problem with the drive.

- **Not attempted**

The firmware was not downloaded, which may be due to a number of different reasons such as the download was stopped before it could occur, or the drive did not qualify for the upgrade, or the download could not occur due to an error.

- **Successful**

The firmware was downloaded successfully.

9. After the drive firmware upgrade completes:

- To close the Drive Firmware Download Wizard, select **Close**.
- To start the wizard again, select **Transfer More**.

10. Once the upgrade operation has completed, reboot the appliance. From the StorageGRID Appliance Installer, select **Advanced > Reboot Controller**, and then select one of these options:

- Select **Reboot into StorageGRID** to reboot the controller with the node rejoining the grid. Select this option if you are done working in maintenance mode and are ready to return the node to normal operation.
- Select **Reboot into Maintenance Mode** to reboot the controller with the node remaining in maintenance mode. Select this option if there are additional maintenance operations you need to perform on the node before rejoining the grid.

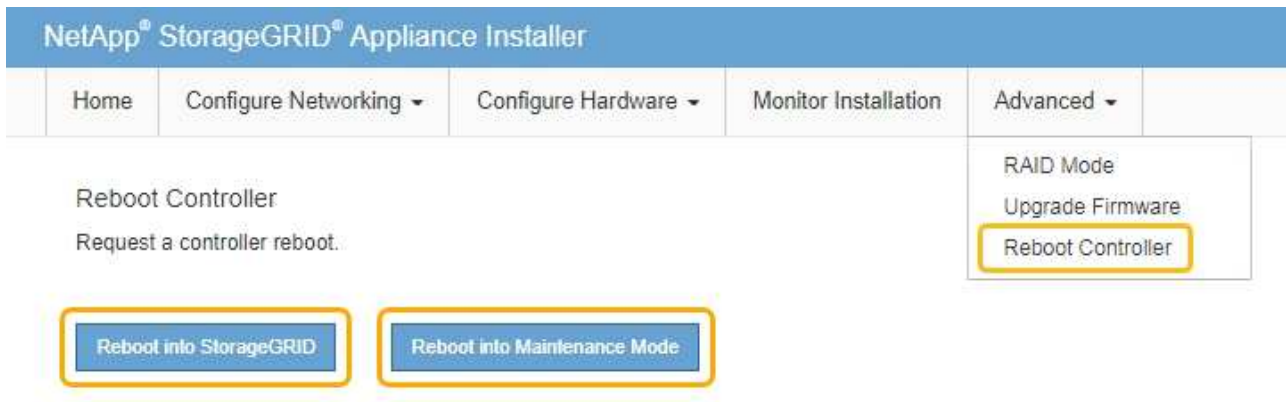

It can take up to 20 minutes for the appliance to reboot and rejoin the grid. To confirm that the reboot is complete and that the node has rejoined the grid, go back to the Grid Manager. The **Nodes** tab should display a normal status ✓ for the appliance node, indicating that no alerts are active and the node is connected to the grid.

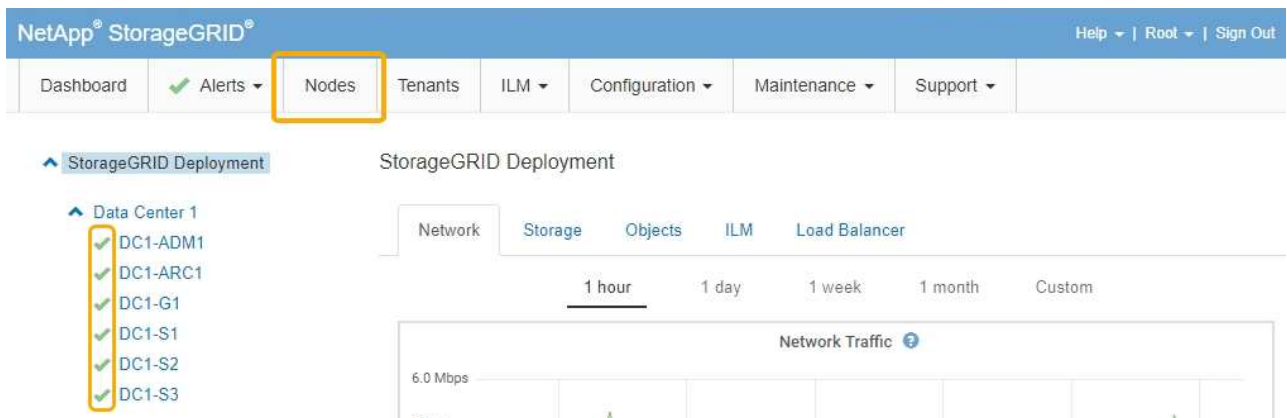

Replacing the E2700 controller

You might need to replace the E2700 controller if it is not functioning optimally or it has failed.

What you'll need

- You have a replacement controller with the same part number as the controller you are replacing.
- You have labels to identify each cable that is connected to the controller.
- You have antistatic protection.
- You must have the Maintenance or Root Access permission. For details, see the instructions for administering StorageGRID.

About this task

You can determine if you have a failed controller by checking the amber Service Action Required LED on the controller (shown as 1 in the illustration). If this LED is on, the controller should be replaced.

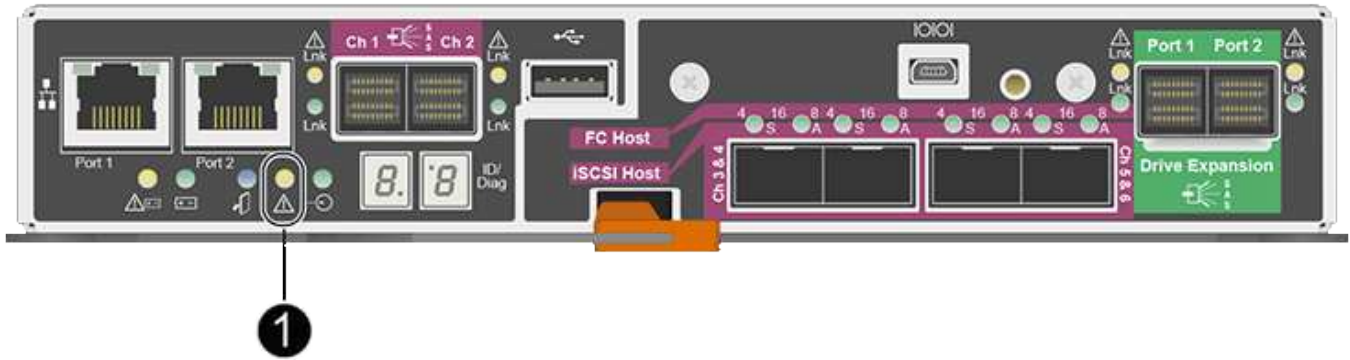

The appliance Storage Node will not be accessible when you replace the controller. If the E2700 controller is functioning sufficiently, you can place the E5600SG controller into maintenance mode.

When you replace a controller, you must remove the battery from the original controller and install it in the replacement controller.

Steps

1. Prepare to remove the controller.

You use SANtricity Storage Manager to perform these steps.

- a. Make a note of which version of SANtricity OS software is currently installed on the controller.
- b. Make a note of which version of NVSRAM is currently installed.
- c. If the Drive Security feature is enabled, be sure a saved key exists and that you know the pass phrase required to install it.



Possible loss of data access -- If all drives in the appliance are security enabled, the new controller will not be able to access the appliance until you unlock the secured drives using the Enterprise Management Window in SANtricity Storage Manager.

- d. Back up the configuration database.

If a problem occurs when you remove a controller, you can use the saved file to restore your configuration.

- e. Collect support data for the appliance.



Collecting support data before and after replacing a component ensures you can send a full set of logs to technical support in case the replacement does not resolve the problem.

2. If the StorageGRID appliance is running in a StorageGRID system, place the E5600SG controller into maintenance mode.

Placing an appliance into maintenance mode

3. If the E2700 controller is functioning sufficiently to allow for a controlled shutdown, confirm that all operations have completed.

- a. From the title bar of the Array Management Window, select **Monitor > Reports > Operations in**

Progress.

- b. Confirm that all operations have completed.
4. Follow the instructions in the replacement procedure for a simplex E2700 controller to complete these steps:
 - a. Label the cables and then disconnect the cables.

i

To prevent degraded performance, do not twist, fold, pinch, or step on the cables.

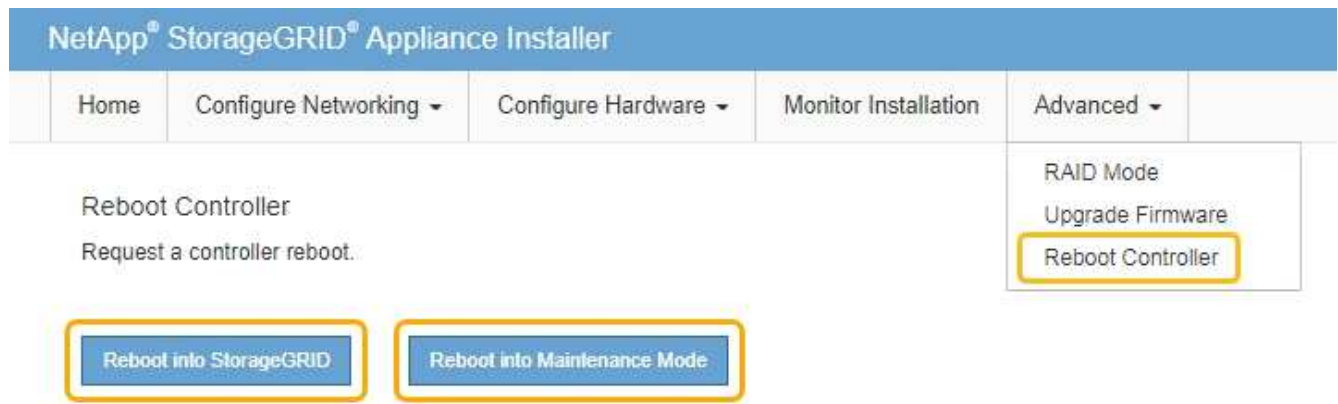

During the reboot, the following screen appears:

Reboot

Shuts down and restarts the node.

Reboot

Maintenance Mode

This node is rebooting from maintenance mode to rejoin the grid. Monitor the node status to determine when the node has successfully rejoined the grid.

The appliance reboots and rejoins the grid. This process can take up to 20 minutes.

- Confirm that the reboot is complete and that the node has rejoined the grid. In the Grid Manager, verify that the **Nodes** tab displays a normal status  for the appliance node, indicating that no alerts are active and the node is connected to the grid.

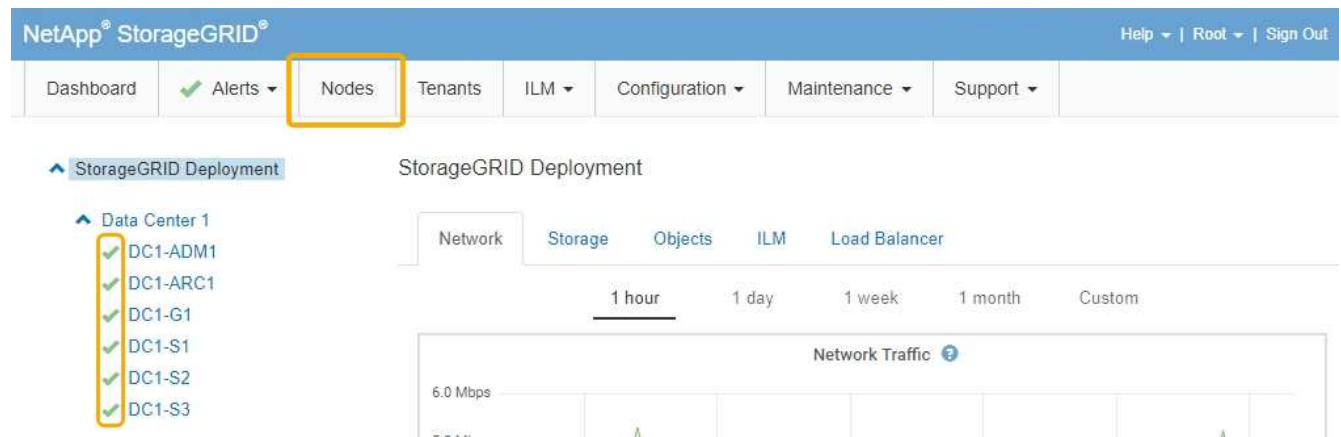

NetApp® StorageGRID® Help | Root | Sign Out

Dashboard Alerts Nodes Tenants ILM Configuration Maintenance Support

StorageGRID Deployment

Data Center 1

- DC1-ADM1
- DC1-ARC1
- DC1-G1
- DC1-S1
- DC1-S2
- DC1-S3

Network Storage Objects ILM Load Balancer

1 hour 1 day 1 week 1 month Custom

Network Traffic

6.0 Mbps

- From SANtricity Storage Manager, confirm that the new controller is Optimal, and collect support data.

Related information

[NetApp E-Series and EF-Series Hardware Replacement Procedures](#)

[NetApp Documentation: E2700 Series](#)

Replacing the E5600SG controller

You might need to replace the E5600SG controller.

What you'll need

You must have access to the following resources:

- E-Series hardware replacement information on the NetApp Support Site at mysupport.netapp.com
- E5600 documentation on the Support Site

- The appliance has been placed maintenance mode.

Placing an appliance into maintenance mode

About this task

If both controllers are functioning sufficiently to allow for a controlled shutdown, you can shut down the E5600SG controller first to interrupt the connectivity to the E2700 controller.



If you are replacing the controller before installing StorageGRID software, you might not be able to access the StorageGRID Appliance Installer immediately after completing this procedure. While you can access the StorageGRID Appliance Installer from other hosts on the same subnet as the appliance, you cannot access it from hosts on other subnets. This condition should resolve itself within 15 minutes (when any ARP cache entries for the original controller time out), or you can clear the condition immediately by purging any old ARP cache entries manually from the local router or gateway.

Steps

1. Use antistatic protection.
2. Label each cable that is attached to the E5600SG controller, so you can reconnect the cables correctly.



To prevent degraded performance, do not twist, fold, pinch, or step on the cables. Do not bend the cables tighter than a 5-cm (2-in) radius.

3. When the appliance has been placed maintenance mode, shut down the E5600SG controller.
 - a. Log in to the grid node:
 - i. Enter the following command: `ssh admin@grid_node_IP`
 - ii. Enter the password listed in the `Passwords.txt` file.
 - iii. Enter the following command to switch to root: `su -`
 - iv. Enter the password listed in the `Passwords.txt` file.

When you are logged in as root, the prompt changes from `$` to `#`.

- b. Shut down the E5600SG controller:

`shutdown -h now`

4. Turn off the power to the enclosure, and wait until all LED and seven-segment display activity on the rear of the controller has stopped.
5. Remove the cables.
6. Remove the controller, as described in the E5600SG controller documentation.
7. Insert the new controller, as described in the E5600SG controller documentation.
8. Replace all cables.
9. Turn the power back on to the enclosure.
10. Monitor the seven-segment codes.
 - E2700 controller:

The final LED state is 99.

- E5600SG controller:

The final LED state is HA.

11. Monitor the status of the appliance Storage Node in the Grid Manager.

Verify that the appliance Storage Nodes returns to the expected status.

Related information

[NetApp E-Series and EF-Series Hardware Replacement Procedures](#)

[NetApp Documentation: E5600 Series](#)

Replacing other hardware components

You might need to replace a drive, fan, power supply, or battery in the StorageGRID appliance.

What you'll need

- You have the E-Series hardware replacement procedure.
- The appliance has been placed in maintenance mode if the component replacement procedure requires that you shut down the appliance.

[Placing an appliance into maintenance mode](#)

About this task

To replace a drive, power-fan canister, fan canister, power canister, battery, or drive drawer, refer to the standard procedures for the E2700 and E5600 storage arrays. Focus on the step-by-step instructions for removing and replacing the hardware itself; many of the SANtricity Storage Manager procedures do not apply to an appliance.

SG5612 component replacement instructions

FRU	See
Drive	Follow the steps in the E-Series instructions for replacing a drive in the E2600, E2700, E5400, E5500, E5600 or 12-drive or 24-drive trays.
Power-fan canister	Follow the steps in the E-Series instructions for replacing a failed power-fan canister in the E5612 or the E5624 controller-drive tray.
Battery in the E2700 controller (requires removing the controller)	Follow the steps in Replacing the E2700 controller , but install the new battery in the existing controller.

SG5660 component replacement instructions

FRU	See
Drive	Follow the steps in the E-Series instructions for replacing a drive in the E2660, E2760, E5460, E5560, or E5660 trays.
Power canister	Follow the steps in the E-Series instructions for replacing a failed power canister in the E5660 controller-drive tray.
Fan canister	Follow the steps in the E-Series instructions for replacing a failed fan canister in the E5660 controller-drive tray.
Battery in the E2700 controller (requires removing the controller)	Follow the steps in Replacing the E2700 controller , but install the new battery in the existing controller.

Related information

[NetApp E-Series and EF-Series Hardware Replacement Procedures](#)

[NetApp Documentation: E2700 Series](#)

[NetApp Documentation: E5600 Series](#)

Changing the link configuration of the E5600SG controller

You can change the Ethernet link configuration of the E5600SG controller. You can change the port bond mode, the network bond mode, and the link speed.

What you'll need

- You must place the E5600SG controller into maintenance mode. Placing the controller into maintenance mode interrupts the connection to the E2700 controller. Putting a StorageGRID appliance into maintenance mode might make the appliance unavailable for remote access.

[Placing an appliance into maintenance mode](#)

About this task

Options for changing the Ethernet link configuration of the E5600SG controller include:

- Changing **Port bond mode** from Fixed to Aggregate, or from Aggregate to Fixed
- Changing **Network bond mode** from Active-Backup to LACP, or from LACP to Active-Backup
- Enabling or disabling VLAN tagging, or changing the value of a VLAN tag
- Changing the link speed from 10-GbE to 25-GbE, or from 25-GbE to 10-GbE

Steps

- Select **Configure Networking > Link Configuration** from the menu.

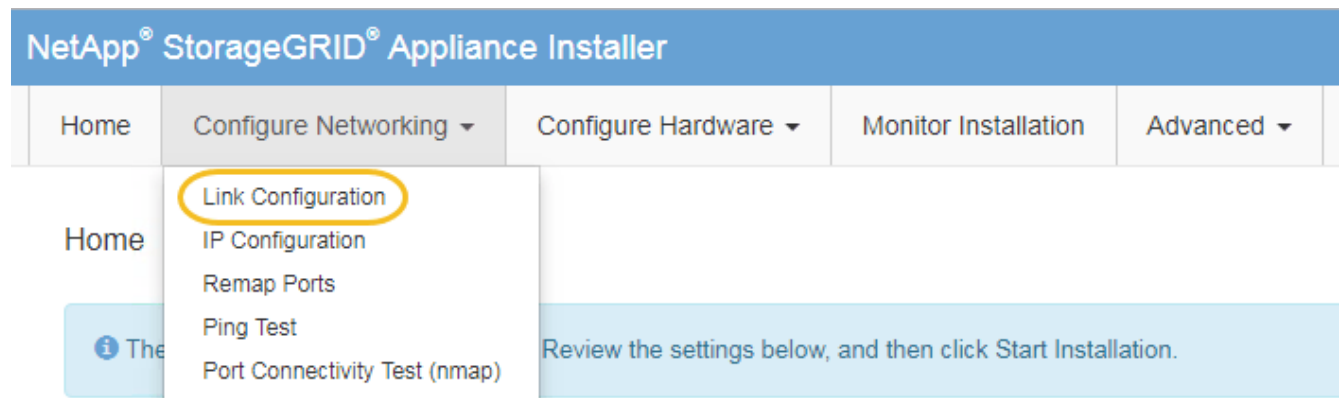

2. Make the desired changes to the link configuration.

For more information on the options, see “Configuring network links.”

3. When you are satisfied with your selections, click **Save**.



You might lose your connection if you made changes to the network or link you are connected through. If you are not reconnected within 1 minute, re-enter the URL for the StorageGRID Appliance Installer using one of the other IP addresses assigned to the appliance:

`https://E5600SG_Controller_IP:8443`

If you made changes to the VLAN settings, the subnet for the appliance might have changed. If you need to change the IP addresses for the appliance, follow the instructions for configuring IP addresses.

Setting the IP configuration

4. From the StorageGRID Appliance Installer, select **Configure Networking > Ping Test**.

5. Use the Ping Test tool to check connectivity to IP addresses on any networks that may have been affected by the link configuration changes you made in the [Change link configuration](#) step.

In addition to any other tests you choose to perform, confirm that you can ping the grid IP address of the primary Admin Node, and the grid IP address of at least one other Storage Node. If necessary, correct any link configuration issues.

6. Once you are satisfied that your link configuration changes are working, reboot the node. From the StorageGRID Appliance Installer, select **Advanced > Reboot Controller**, and then select one of these options:

- Select **Reboot into StorageGRID** to reboot the controller with the node rejoining the grid. Select this option if you are done working in maintenance mode and are ready to return the node to normal operation.
- Select **Reboot into Maintenance Mode** to reboot the controller with the node remaining in maintenance mode. Select this option if there are additional maintenance operations you need to perform on the node before rejoining the grid.

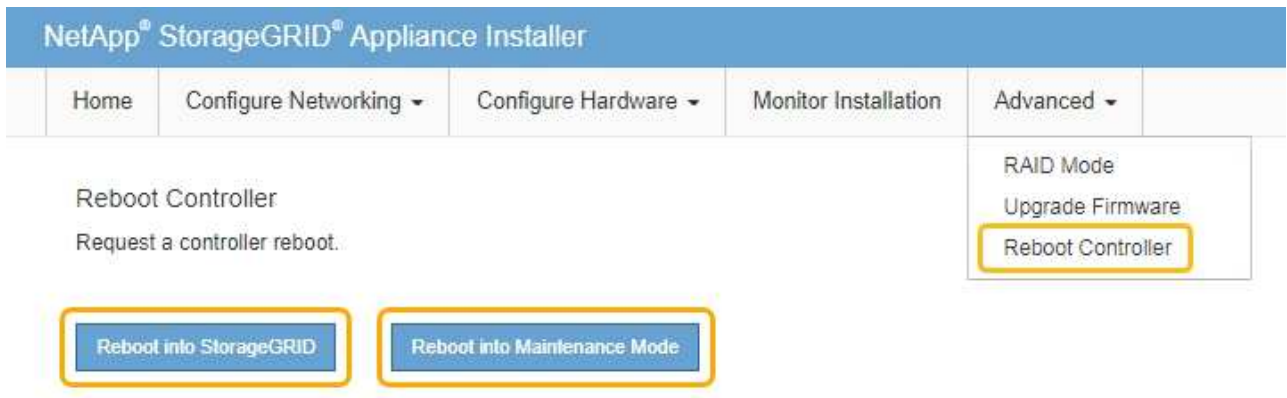

It can take up to 20 minutes for the appliance to reboot and rejoin the grid. To confirm that the reboot is complete and that the node has rejoined the grid, go back to the Grid Manager. The **Nodes** tab should display a normal status ✓ for the appliance node, indicating that no alerts are active and the node is connected to the grid.

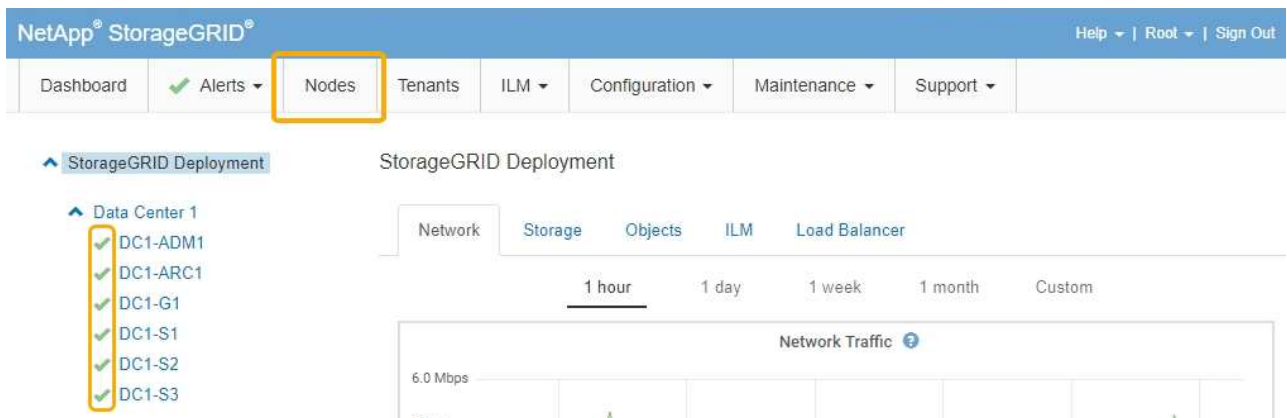

Related information

[Configuring network links \(SG5600\)](#)

Changing the MTU setting

You can change the MTU setting that you assigned when you configured IP addresses for the appliance node.

What you'll need

The appliance has been placed in maintenance mode.

[Placing an appliance into maintenance mode](#)

Steps

1. From the StorageGRID Appliance Installer, select **Configure Networking > IP Configuration**.
2. Make the desired changes to the MTU settings for the Grid Network, Admin Network, and Client Network.

Grid Network

The Grid Network is used for all internal StorageGRID traffic. The Grid Network provides connectivity between all nodes in the grid, across all sites and subnets. All hosts on the Grid Network must be able to talk to all other hosts. The Grid Network can consist of multiple subnets. Networks containing critical grid services, such as NTP, can also be added as Grid subnets.

IP Assignment Static DHCP



IPv4 Address (CIDR)

Gateway

 All required Grid Network subnets must also be defined in the Grid Network Subnet List on the Primary Admin Node before starting installation.

Subnets (CIDR) 



MTU 



The MTU value of the network must match the value configured on the switch port the node is connected to. Otherwise, network performance issues or packet loss might occur.



For the best network performance, all nodes should be configured with similar MTU values on their Grid Network interfaces. The **Grid Network MTU mismatch** alert is triggered if there is a significant difference in MTU settings for the Grid Network on individual nodes. The MTU values do not have to be the same for all network types.

- When you are satisfied with the settings, select **Save**.
- Reboot the node. From the StorageGRID Appliance Installer, select **Advanced > Reboot Controller**, and then select one of these options:
 - Select **Reboot into StorageGRID** to reboot the controller with the node rejoining the grid. Select this

option if you are done working in maintenance mode and are ready to return the node to normal operation.

- Select **Reboot into Maintenance Mode** to reboot the controller with the node remaining in maintenance mode. Select this option if there are additional maintenance operations you need to perform on the node before rejoining the grid.



It can take up to 20 minutes for the appliance to reboot and rejoin the grid. To confirm that the reboot is complete and that the node has rejoined the grid, go back to the Grid Manager. The **Nodes** tab should display a normal status ✓ for the appliance node, indicating that no alerts are active and the node is connected to the grid.

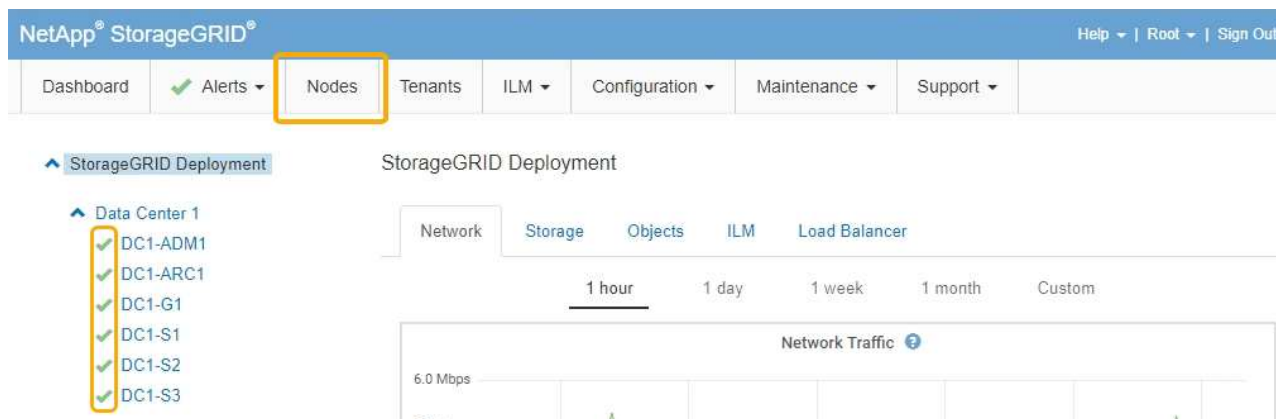

Related information

[Administer StorageGRID](#)

Checking the DNS server configuration

You can check and temporarily change the domain name system (DNS) servers that are currently in use by this appliance node.

What you'll need

The appliance has been placed in maintenance mode.

[Placing an appliance into maintenance mode](#)

About this task

You might need to change the DNS server settings if an encrypted appliance cannot connect to the key management server (KMS) or KMS cluster because the hostname for the KMS was specified as a domain name instead of an IP address. Any changes that you make to the DNS settings for the appliance are temporary and are lost when you exit maintenance mode. To make these changes permanent, specify the DNS servers in Grid Manager (**Maintenance > Network > DNS Servers**).

- Temporary changes to the DNS configuration are necessary only for node-encrypted appliances where the KMS server is defined using a fully qualified domain name, instead of an IP address, for the hostname.
- When a node-encrypted appliance connects to a KMS using a domain name, it must connect to one of the DNS servers defined for the grid. One of these DNS servers then translates the domain name into an IP address.
- If the node cannot reach a DNS server for the grid, or if you changed the grid-wide DNS settings when a node-encrypted appliance node was offline, the node is unable to connect to the KMS. Encrypted data on the appliance cannot be decrypted until the DNS issue is resolved.

To resolve a DNS issue preventing KMS connection, specify the IP address of one or more DNS servers in the StorageGRID Appliance Installer. These temporary DNS settings allow the appliance to connect to the KMS and decrypt data on the node.

For example, if the DNS server for the grid changes while an encrypted node was offline, the node will not be able to reach the KMS when it comes back online, since it is still using the previous DNS values. Entering the new DNS server IP address in the StorageGRID Appliance Installer allows a temporary KMS connection to decrypt the node data.



Steps

1. From the StorageGRID Appliance Installer, select **Configure Networking > DNS Configuration**.
2. Verify that the DNS servers specified are correct.

DNS Servers

 Configuration changes made on this page will not be passed to the StorageGRID software after appliance installation.

Servers

Server 1	<input type="text" value="10.224.223.135"/>	
Server 2	<input type="text" value="10.224.223.136"/>	 
<input type="button" value="Cancel"/>		<input type="button" value="Save"/>

3. If required, change the DNS servers.



Changes made to the DNS settings are temporary and are lost when you exit maintenance mode.

4. When you are satisfied with the temporary DNS settings, select **Save**.

The node uses the DNS server settings specified on this page to reconnect to the KMS, allowing data on the node to be decrypted.

- After node data is decrypted, reboot the node. From the StorageGRID Appliance Installer, select **Advanced > Reboot Controller**, and then select one of these options:
 - Select **Reboot into StorageGRID** to reboot the controller with the node rejoining the grid. Select this option if you are done working in maintenance mode and are ready to return the node to normal operation.
 - Select **Reboot into Maintenance Mode** to reboot the controller with the node remaining in maintenance mode. Select this option if there are additional maintenance operations you need to perform on the node before rejoining the grid.

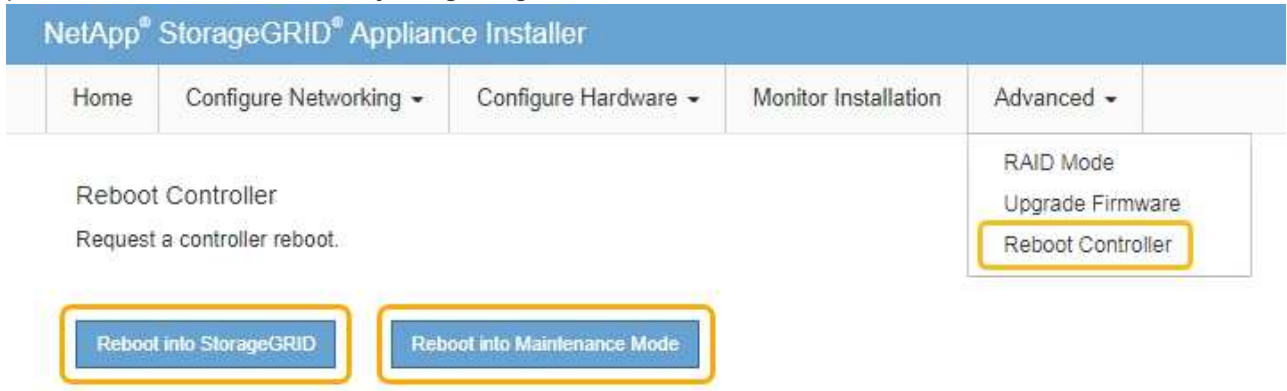

When the node reboots and rejoins the grid, it uses the system-wide DNS servers listed in the Grid Manager. After rejoining the grid, the appliance will no longer use the temporary DNS servers specified in the StorageGRID Appliance Installer while the appliance was in maintenance mode.

It can take up to 20 minutes for the appliance to reboot and rejoin the grid. To confirm that the reboot is complete and that the node has rejoined the grid, go back to the Grid Manager. The **Nodes** tab should display a normal status ✓ for the appliance node, indicating that no alerts are active and the node is connected to the grid.

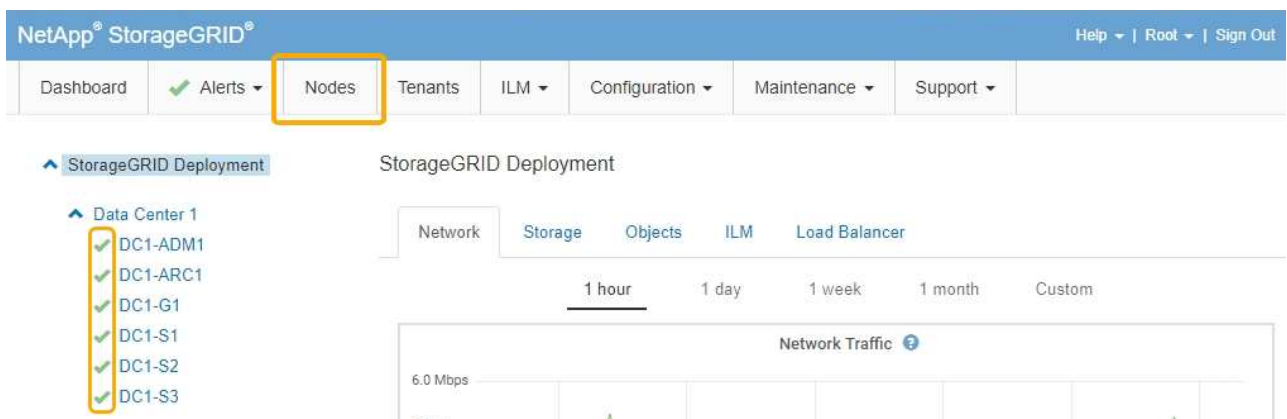

Monitoring node encryption in maintenance mode

If you enabled node encryption for the appliance during installation, you can monitor the node-encryption status of each appliance node, including the node-encryption state and key management server (KMS) details.

What you'll need

- Node encryption must have been enabled for the appliance during installation. You cannot enable node encryption after the appliance is installed.
- The appliance has been placed into maintenance mode.

[Placing an appliance into maintenance mode](#)

Steps

1. From the StorageGRID Appliance Installer, select **Configure Hardware > Node Encryption**.

Node Encryption

Node encryption allows you to use an external key management server (KMS) to encrypt all StorageGRID data on this appliance. If node encryption is enabled for the appliance and a KMS is configured for the site, you cannot access any data on the appliance unless the appliance can communicate with the KMS.

Encryption Status

 You can only enable node encryption for an appliance during installation. You cannot enable or disable the node encryption setting after the appliance is installed.

Enable node encryption

Save

Key Management Server Details

View the status and configuration details for the KMS that manages the encryption key for this appliance. You must use the Grid Manager to make configuration changes.

KMS display name	thales
External key UID	41b0306abcce451facfe01b1b4870ae1c1ec6bd5e3849d790223766baf35c57
Hostnames	10.96.99.164 10.96.99.165
Port	5696

Server certificate >

Client certificate >

Clear KMS Key

 Do not clear the KMS key if you need to access or preserve any data on this appliance.

If you want to reinstall this appliance node (for example, in another grid), you must clear the KMS key. When the KMS key is cleared, all data on this appliance is deleted.

Clear KMS Key and Delete Data

The Node Encryption page includes these three sections:

- Encryption Status shows whether node encryption is enabled or disabled for the appliance.
- Key Management Server Details shows information about the KMS being used to encrypt the appliance. You can expand the server and client certificate sections to view certificate details and status.

- To address issues with the certificates themselves, such as renewing expired certificates, see the information about KMS in the instructions for administering StorageGRID.
- If there are unexpected problems connecting to KMS hosts, verify that the domain name system (DNS) servers are correct and that appliance networking is correctly configured.

Checking the DNS server configuration

- If you are unable to resolve your certificate issues, contact technical support.
- Clear KMS Key disables node encryption for the appliance, removes the association between the appliance and the key management server that was configured for the StorageGRID site, and deletes all data from the appliance. You must clear the KMS key before you can install the appliance into another StorageGRID system.

Clearing the key management server configuration



Clearing the KMS configuration deletes data from the appliance, rendering it permanently inaccessible. This data is not recoverable.

2. When you are done checking node-encryption status, reboot the node. From the StorageGRID Appliance Installer, select **Advanced > Reboot Controller**, and then select one of these options:

- Select **Reboot into StorageGRID** to reboot the controller with the node rejoining the grid. Select this option if you are done working in maintenance mode and are ready to return the node to normal operation.
- Select **Reboot into Maintenance Mode** to reboot the controller with the node remaining in maintenance mode. Select this option if there are additional maintenance operations you need to perform on the node before rejoining the grid.

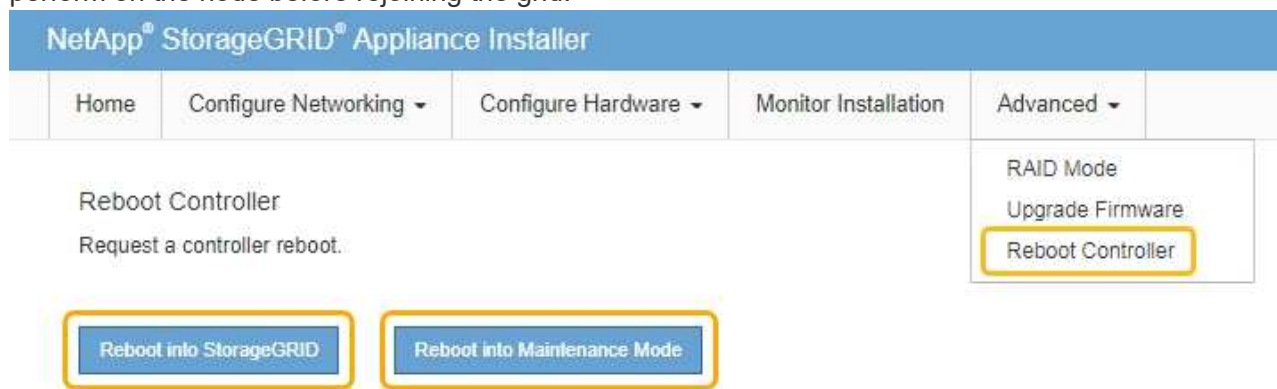

It can take up to 20 minutes for the appliance to reboot and rejoin the grid. To confirm that the reboot is complete and that the node has rejoined the grid, go back to the Grid Manager. The **Nodes** tab should display a normal status for the appliance node, indicating that no alerts are active and the node is connected to the grid.

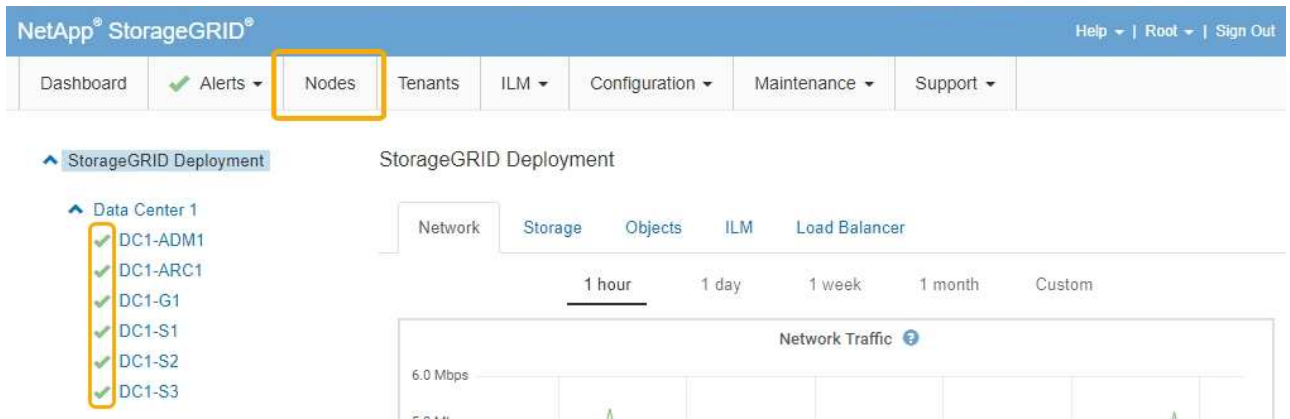

Related information

[Administer StorageGRID](#)

Clearing the key management server configuration

Clearing the key management server (KMS) configuration disables node encryption on your appliance. After clearing the KMS configuration, the data on your appliance is permanently deleted and is no longer accessible. This data is not recoverable.

What you'll need

If you need to preserve data on the appliance, you must perform a node decommissioning procedure before you clear the KMS configuration.



When KMS is cleared, data on the appliance will be permanently deleted and no longer accessible. This data is not recoverable.

Decommission the node to move any data it contains to other nodes in StorageGRID. See the recovery and maintenance instructions for grid node decommissioning.

About this task

Clearing the appliance KMS configuration disables node encryption, removing the association between the appliance node and the KMS configuration for the StorageGRID site. Data on the appliance is then deleted and the appliance is left in a pre-install state. This process cannot be reversed.

You must clear the KMS configuration:

- Before you can install the appliance into another StorageGRID system, that does not use a KMS or that uses a different KMS.



Do not clear the KMS configuration if you plan to reinstall an appliance node in a StorageGRID system that uses the same KMS key.

- Before you can recover and reinstall a node where the KMS configuration was lost and the KMS key is not recoverable.
- Before returning any appliance that was previously in use at your site.
- After decommissioning a appliance that had node encryption enabled.



Decommission the appliance before clearing KMS to move its data to other nodes in your StorageGRID system. Clearing KMS before decommissioning the appliance will result in data loss and might render the appliance inoperable.

Steps

1. Open a browser, and enter one of the IP addresses for the appliance's compute controller.

`https://Controller_IP:8443`

Controller_IP is the IP address of the compute controller (not the storage controller) on any of the three StorageGRID networks.

The StorageGRID Appliance Installer Home page appears.

2. Select **Configure Hardware > Node Encryption**.

Node Encryption

Node encryption allows you to use an external key management server (KMS) to encrypt all StorageGRID data on this appliance. If node encryption is enabled for the appliance and a KMS is configured for the site, you cannot access any data on the appliance unless the appliance can communicate with the KMS.

Encryption Status

You can only enable node encryption for an appliance during installation. You cannot enable or disable the node encryption setting after the appliance is installed.

Enable node encryption

Save

Key Management Server Details

View the status and configuration details for the KMS that manages the encryption key for this appliance. You must use the Grid Manager to make configuration changes.

KMS display name	thales
External key UID	41b0306abcce451facfe01b1b4870ae1c1ec6bd5e3849d790223766baf35c57
Hostnames	10.96.99.164 10.96.99.165
Port	5696

Server certificate >

Client certificate >

Clear KMS Key

Do not clear the KMS key if you need to access or preserve any data on this appliance.

If you want to reinstall this appliance node (for example, in another grid), you must clear the KMS key. When the KMS key is cleared, all data on this appliance is deleted.

Clear KMS Key and Delete Data



If the KMS configuration is cleared, data on the appliance will be permanently deleted. This data is not recoverable.

3. At the bottom of the window, select **Clear KMS Key and Delete Data**.
4. If you are sure that you want to clear the KMS configuration, type **clear** and select **Clear KMS Key and Delete Data**.

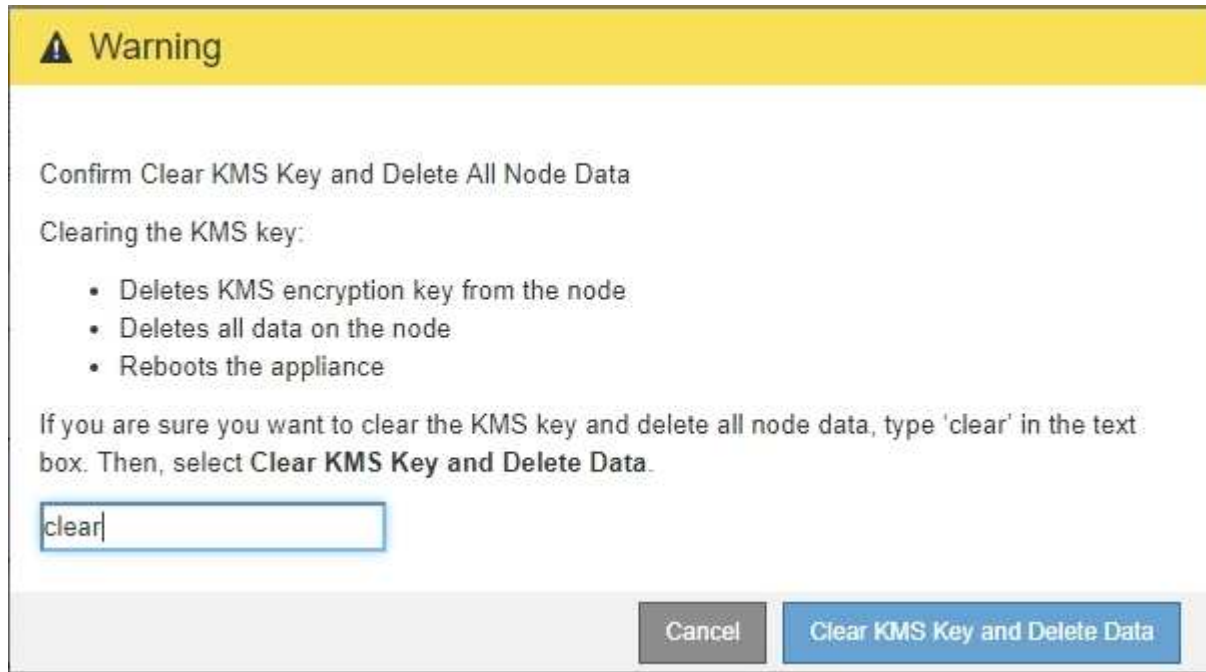

The KMS encryption key and all data are deleted from the node, and the appliance reboots. This can take up to 20 minutes.

5. Open a browser, and enter one of the IP addresses for the appliance's compute controller.
`https://Controller_IP:8443`

Controller_IP is the IP address of the compute controller (not the storage controller) on any of the three StorageGRID networks.

The StorageGRID Appliance Installer Home page appears.

6. Select **Configure Hardware > Node Encryption**.
7. Verify that node encryption is disabled and that the key and certificate information in **Key Management Server Details** and the **Clear KMS Key and Delete Data** control are removed from the window.

Node encryption cannot be reenabled on the appliance until it is reinstalled in a grid.

After you finish

After the appliance reboots and you have verified that KMS has been cleared and that the appliance is in a pre-install state, you can physically remove the appliance from your StorageGRID system. See the recovery and maintenance instructions for information about preparing an appliance for reinstallation.

Related information

[Administer StorageGRID](#)

Copyright information

Copyright © 2025 NetApp, Inc. All Rights Reserved. Printed in the U.S. No part of this document covered by copyright may be reproduced in any form or by any means—graphic, electronic, or mechanical, including photocopying, recording, taping, or storage in an electronic retrieval system—without prior written permission of the copyright owner.

Software derived from copyrighted NetApp material is subject to the following license and disclaimer:

THIS SOFTWARE IS PROVIDED BY NETAPP "AS IS" AND WITHOUT ANY EXPRESS OR IMPLIED WARRANTIES, INCLUDING, BUT NOT LIMITED TO, THE IMPLIED WARRANTIES OF MERCHANTABILITY AND FITNESS FOR A PARTICULAR PURPOSE, WHICH ARE HEREBY DISCLAIMED. IN NO EVENT SHALL NETAPP BE LIABLE FOR ANY DIRECT, INDIRECT, INCIDENTAL, SPECIAL, EXEMPLARY, OR CONSEQUENTIAL DAMAGES (INCLUDING, BUT NOT LIMITED TO, PROCUREMENT OF SUBSTITUTE GOODS OR SERVICES; LOSS OF USE, DATA, OR PROFITS; OR BUSINESS INTERRUPTION) HOWEVER CAUSED AND ON ANY THEORY OF LIABILITY, WHETHER IN CONTRACT, STRICT LIABILITY, OR TORT (INCLUDING NEGLIGENCE OR OTHERWISE) ARISING IN ANY WAY OUT OF THE USE OF THIS SOFTWARE, EVEN IF ADVISED OF THE POSSIBILITY OF SUCH DAMAGE.

NetApp reserves the right to change any products described herein at any time, and without notice. NetApp assumes no responsibility or liability arising from the use of products described herein, except as expressly agreed to in writing by NetApp. The use or purchase of this product does not convey a license under any patent rights, trademark rights, or any other intellectual property rights of NetApp.

The product described in this manual may be protected by one or more U.S. patents, foreign patents, or pending applications.

LIMITED RIGHTS LEGEND: Use, duplication, or disclosure by the government is subject to restrictions as set forth in subparagraph (b)(3) of the Rights in Technical Data -Noncommercial Items at DFARS 252.227-7013 (FEB 2014) and FAR 52.227-19 (DEC 2007).

Data contained herein pertains to a commercial product and/or commercial service (as defined in FAR 2.101) and is proprietary to NetApp, Inc. All NetApp technical data and computer software provided under this Agreement is commercial in nature and developed solely at private expense. The U.S. Government has a non-exclusive, non-transferrable, nonsublicensable, worldwide, limited irrevocable license to use the Data only in connection with and in support of the U.S. Government contract under which the Data was delivered. Except as provided herein, the Data may not be used, disclosed, reproduced, modified, performed, or displayed without the prior written approval of NetApp, Inc. United States Government license rights for the Department of Defense are limited to those rights identified in DFARS clause 252.227-7015(b) (FEB 2014).

Trademark information

NETAPP, the NETAPP logo, and the marks listed at <http://www.netapp.com/TM> are trademarks of NetApp, Inc. Other company and product names may be trademarks of their respective owners.